

Data Projector

Operating Instructions

Before operating the unit, please read this manual and supplied Quick Reference Manual thoroughly and retain it for future reference.

VPL-DX140/DX120/DX100

VPL-DW120

Not all models are available in all countries and area. Please check with your local Sony Authorized Dealer.

HDMI

Table of Contents

Overview

| | |
|--|---|
| Location and Function of Controls | 3 |
| Main Unit | 3 |
| Connector Panel | 4 |
| Remote Commander and Control Panel Keys | 5 |

Preparation

| | |
|-----------------------------------|---|
| Connecting the Projector | 7 |
| Connecting a Computer | 7 |
| Connecting a Video equipment | 8 |

Projecting/Adjusting an Image

| | |
|-----------------------------------|----|
| Projecting an Image | 9 |
| Adjusting the Projected image ... | 10 |
| Turning Off the Power | 13 |

Adjustments and Settings Using a Menu

| | |
|---------------------------------|----|
| Using a MENU | 14 |
| The Picture Menu | 15 |
| The Screen Menu | 16 |
| The Function Menu | 20 |
| The Operation Menu | 21 |
| The Connection/Power Menu | 22 |
| The Installation Menu | 23 |
| The Information Menu | 24 |

Others

| | |
|-------------------------------|----|
| Indicators | 25 |
| Messages List | 26 |
| Troubleshooting | 27 |
| Replacing the Lamp | 29 |
| Cleaning the Air Filter | 31 |
| Specifications | 32 |
| Projection Distance | 37 |
| Dimensions | 42 |
| Index | 45 |

Location and Function of Controls

Main Unit

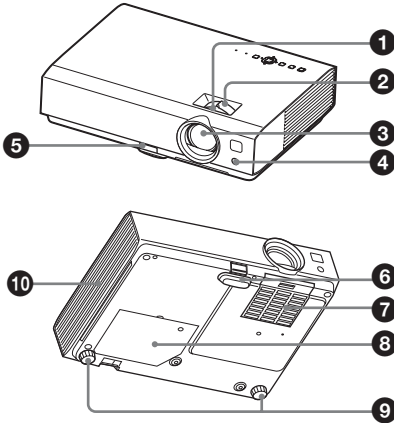

- ❶ Focus ring (page 10)
- ❷ Zoom ring (page 10)
- ❸ Lens
- ❹ Remote control detector
- ❺ Adjuster button (page 11)
- ❻ Adjuster (page 11)
- ❼ Air filter cover/Ventilation holes (intake) (page 31)
- ❽ Lamp cover (page 29)
- ❾ Adjuster (page 11)
- ❿ Ventilation holes (exhaust)

Caution

Do not place anything near the ventilation holes as this may cause internal heat buildup. Do not place your hand near the ventilation holes and the circumference as this may cause injury.

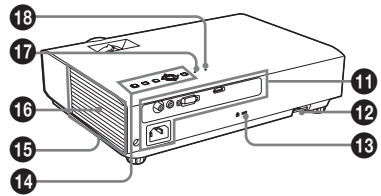

- ❶ Connector panel (page 4)
- ❷ Security bar
Connects to a commercially available security chain or wire.
- ❸ Security lock
Connects to an optional security cable manufactured by Kensington.
For details, visit Kensington's web site.
<http://www.kensington.com/>
- ❹ Control panel keys (page 5)
- ❺ Ventilation holes (intake)
- ❻ Speaker
- ❼ LAMP/COVER indicator (page 25)
- ❽ ON/STANDBY indicator (page 25)

Connector Panel

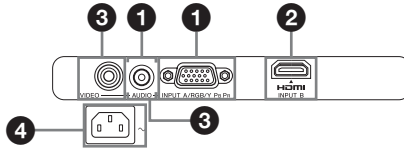

Input (pages 7, 8)

1 INPUT A

Video: RGB/YPbPr input connector

Audio: Audio input connector

2 INPUT B

Video: HDMI input connector

Audio: HDMI input connector

3 VIDEO

Video: Video input connector

Audio: Audio input connector

Note

The audio inputs of INPUT A and VIDEO are shared.

Others

4 AC IN (~) socket

Connects the supplied AC power cord.

Remote Commander and Control Panel Keys

Remote Commander

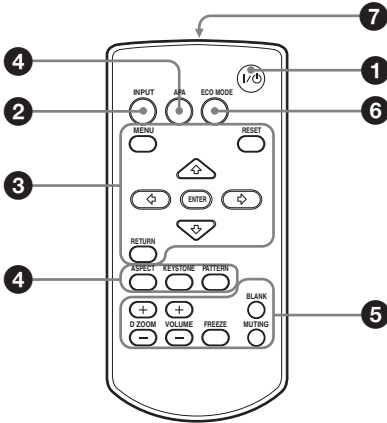

Control Panel Keys

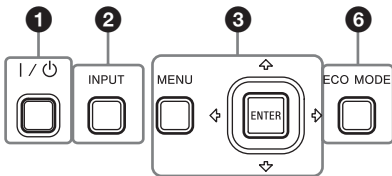

1 Turning on the power/Going to standby mode
I/⏻ (On/Standby) key

2 Selecting an input signal (page 9)
INPUT key

3 Operating a menu (page 14)
MENU key
RESET key
ENTER /▲/▼/◀/▶ (arrow) keys
RETURN key

4 Adjusting the image (page 10)
ASPECT key (page 16)
KEYSTONE key (page 12)
PATTERN key (page 10)
APA (Auto Pixel Alignment) key* (page 12)

Note

* Use this key when inputting a computer signal via the RGB input connector (INPUT A).

5 Using various functions during projecting

D ZOOM (Digital Zoom) +/- key*¹
Enlarges a portion of the image while projecting.

1 Press the D ZOOM + key to display the digital zoom icon on the projected image.

2 Press the ▲/▼/◀/▶ keys to move the digital zoom icon to the point on the image you want to enlarge.

3 Press the D ZOOM + key or the D ZOOM – key repeatedly to change the enlargement ratio. The image can be enlarged up to 4 times.

Press the RESET key to restore the previous image.

BLANK key

Cuts off the projected image temporarily. Press again to restore the previous image. Picture muting helps reduce power consumption.

MUTING key

Mutes the audio output temporarily. Press again to restore the previous volume.

VOLUME +/- key

Adjusts the volume output.

FREEZE key*2

Pauses a projected image. Press again to restore the image.

Notes

*1: Use this key when inputting a computer signal. But it may not be used depending on the resolution of the input signal.

*2: Use this key when inputting a computer signal.

6 Setting the energy-saving mode easily

ECO MODE key

Energy-saving mode can be set easily. Energy-saving mode consists of “Lamp Mode,” “With No Input,” and “With Static Signal.”

1 Press the ECO MODE key to display the ECO Mode menu.

ECO Mode Menu

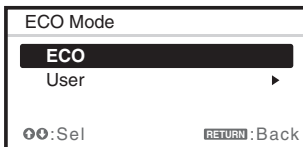

2 Press the \uparrow/\downarrow key or ECO MODE key to select “ECO” or “User” mode.

ECO: Sets each mode to the optimum energy-saving value.

Lamp Mode: Low

With No Input: Standby

With Static Signal: Lamp Dimming

User: Sets each item of the ECO mode menu as you desire (go to step 3).

3 Select “User” then press the \rightarrow key. The setting items appear.

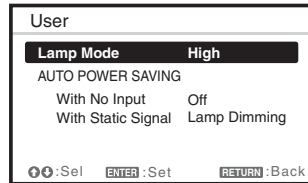

4 Press the \uparrow/\downarrow key to select the item then press the ENTER key.

5 Press the \uparrow/\downarrow key to select the setting value.

6 Press the ENTER key.

The screen returns to the previous menu.

For details on ECO Mode settings, see “Lamp Mode”, “With No Input” and “With Static Signal” on the Connection/Power menu (page 22).

Others

7 Infrared transmitter

About remote commander operation

- Direct the remote commander toward the remote control detector.
- The shorter the distance between the remote commander and the projector is, the wider the angle within which the remote commander can control the projector becomes.
- Make sure that nothing obstructs the infrared beam between the remote commander and the remote control detector on the projector.

Connecting the Projector

Notes

- Make sure all the equipment is powered off when connecting the projector.
- Use the proper cables for each connection.
- Insert the cable plugs firmly; Loose connections may reduce performance of picture signals or cause a malfunction. When pulling out a cable, be sure to grip it by the plug, not the cable itself.
- For more information, refer also to the instruction manuals of the equipment you are connecting.
- Use a no-resistance audio cable.

Connecting a Computer

Connection with a computer is explained for each input signal.

INPUT A

For connecting a computer with an RGB output connector.

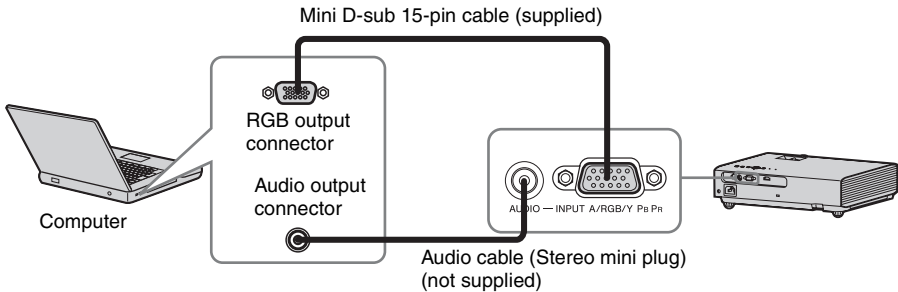

INPUT B

For connecting a computer with an HDMI output connector.

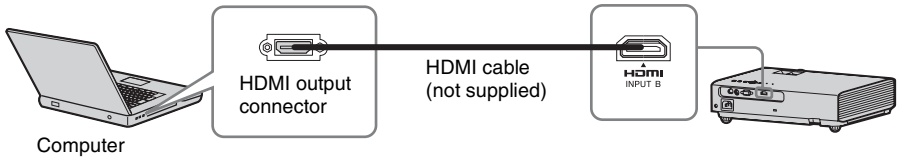

Notes

- Use HDMI-compatible equipment and cable(s) that have an HDMI logo on them.
- The HDMI connector of this projector is not compatible with DSD (Direct Stream Digital) Signal or CEC (Consumer Electronics Control) Signal.
- It is recommended that you set the resolution of your computer to 1024 × 768 pixels (VPL-DX140/DX120/DX100) or 1280 × 800 pixels (VPL-DW120) for the external monitor.

Connecting a Video equipment

Connections with a VHS video deck, DVD player, or BD player are explained for each input signal.

VIDEO

For connecting video equipment with a video output connector.

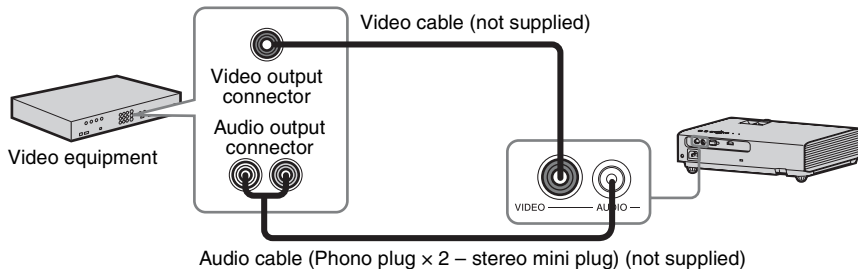

INPUT A

For connecting video equipment with a YPbPr output connector.

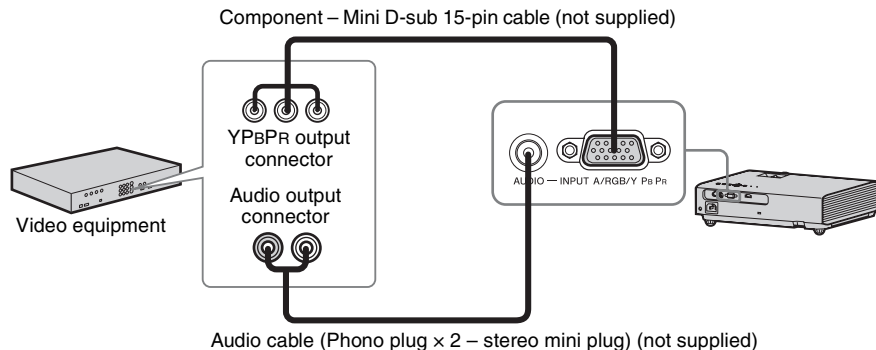

INPUT B

For connecting video equipment with an HDMI output connector.

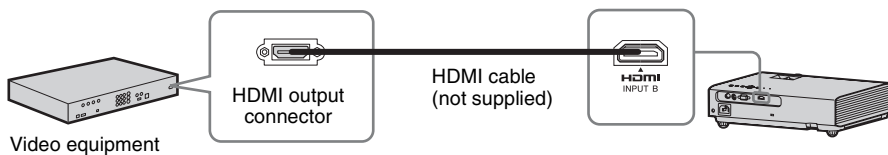

Notes

- Use HDMI-compatible equipment and cable(s) that have an HDMI logo on them.
- The HDMI connector of this projector is not compatible with DSD (Direct Stream Digital) Signal or CEC (Consumer Electronics Control) Signal.

Projecting an Image

The size of a projected image depends on the distance between the projector and screen. Install the projector so that the projected image fits the screen size. For details on projection distances and projected image sizes, see “Projection Distance” (page 37).

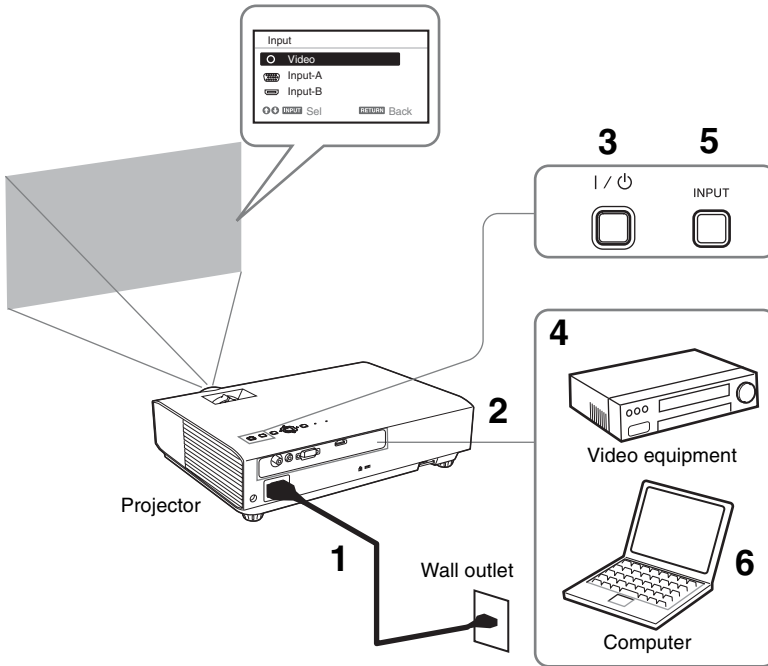

Projecting/Adjusting an Image

- 1** Plug the AC power cord into the wall outlet.
- 2** Connect all equipment to the projector (page 7).
- 3** Press the I/⏻ key to turn on the unit.
- 4** Turn on the connected equipment.
- 5** Select the input source.
Press the INPUT key on the projector to display the menu for switching input signal on the screen. Press the INPUT key repeatedly, or press the ⬆/⬇ key to select an image to be projected.



- 6** When projecting a computer image, switch your computer's output to external display.
The method to switch the output varies depending on the type of computer.

(Example)

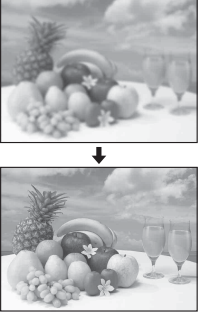

- 7** Adjust the focus, size and position of the projected image (page 10).

Adjusting the Projected image

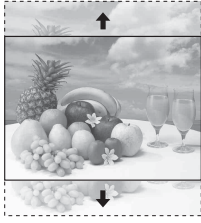
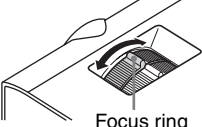
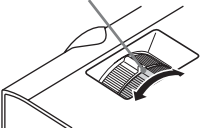
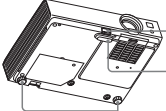
| Focus | Size (Zoom) | Position |
|---|--|--|
|  |  |  |
|  <p data-bbox="266 671 356 695">Focus ring</p> | <p data-bbox="482 552 572 576">Zoom ring</p>  |  <p data-bbox="893 555 972 603">Adjuster button</p> <p data-bbox="893 619 972 643">Adjuster</p> <p data-bbox="770 683 848 707">Adjuster</p> |

Displaying a pattern for adjusting an image

You can display a pattern for adjusting the projected image with the **PATTERN** key on the remote commander. Press the **PATTERN** key again to restore the previous image.



Adjusting the tilt of the projector with the adjusters

By changing the tilt of the projector with adjusters, you can adjust the position of the projected image.

- 1 Press and hold the adjuster button, then lift up the front of the projector to adjust the angle.

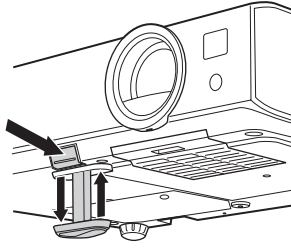
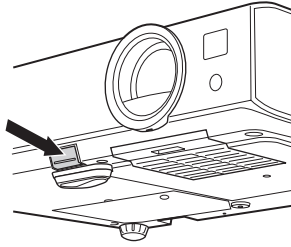

- 2 When the desired angle is achieved, release the adjuster button to lock the position.
- 3 Set the angle of the projector precisely by turning the two rear adjusters.

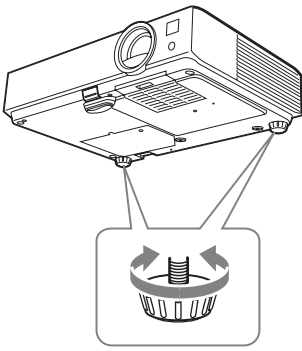

Notes

- Be careful not to let the projector down on your fingers.
- Do not push hard on the top of the projector with the adjuster extended.
- Do not forcibly turn the rear adjusters more than they should be adjusted. Doing so may break them.

Changing the aspect ratio of the projected image

Press the ASPECT key on the remote commander to change the aspect ratio of the projected image. You can also change the setting in Aspect of the Screen menu (pages 16, 18).

Correcting trapezoidal distortion of the projected image (Keystone feature)

Keystone feature may not work automatically when the screen is tilted. In this case, set keystone manually.

- 1 Press the KEYSTONE key on the remote commander or select V Keystone in the Installation menu.
- 2 Use the $\uparrow/\downarrow/\leftarrow/\rightarrow$ the keys to set the value. The higher the value, the narrower the top of the projected image. The lower the value, the narrower the bottom.

Note

- Since the Keystone adjustment is an electronic correction, the image may be deteriorated.

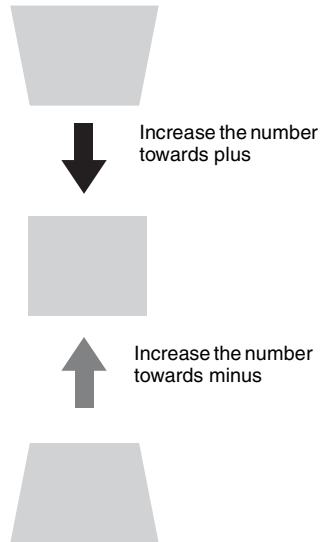

Automatically adjusts Phase, Pitch and Shift of projected image while a signal is input from a computer (APA (Auto Pixel Alignment))

Press the APA key on the remote commander. Press again to cancel adjusting during the setting. You can also set APA in the Screen Menu (page 17). If Smart APA in the Function menu is set to "On", executes APA automatically when a signal is input (page 20).

Turning Off the Power

- 1 Press the I/⏻ key on the unit or the remote commander.
The projector starts shutdown and turns off. If you press the I/⏻ key within 10 seconds of the message being displayed, shutdown is canceled.
- 2 Unplug the AC power cord from the wall outlet.

To turn off without displaying confirmation message

Press and hold the I/⏻ key on the unit for a few seconds (page 26).

ECO gauge

This gauge indicates the current effectiveness of the projector's ECO function. (For details on the ECO function, see "ECO MODE key" (page 6) and "ECO" (page 22).) The leaf icons are displayed when the projector is shut down. The number of displayed icons varies according to how much energy is saved as a result of using the ECO function.

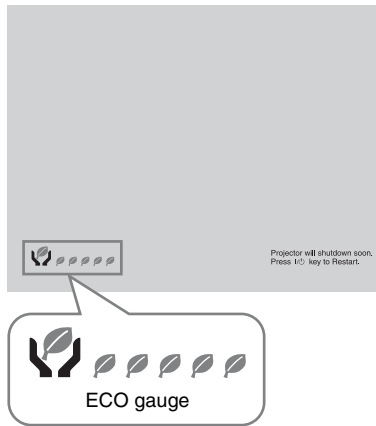

Using a MENU

Note

The menu displays used for the explanation below may be different depending on the model you are using.

- 1 Press the MENU key to display the menu.
- 2 Select the setting menu.
Use the \uparrow/\downarrow key to select the setting menu then press the \rightarrow key or ENTER key.

Setting menu

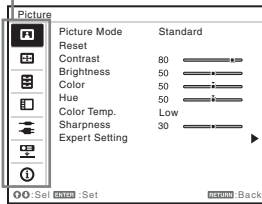

- 3 Select the setting item.
Use the \uparrow/\downarrow key to select the setting menu then press the \rightarrow key or ENTER key.
To return to the selection screen of the setting menu, press the \leftarrow or RETURN key.

Setting items

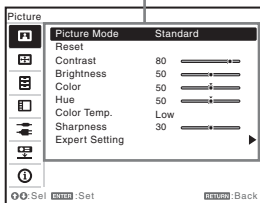

- 4 Make the setting or adjustment for the selected item.
The setting method varies, depending on the setting item.
If the next menu window is displayed, select the item according to the

operations in step 3 and then press the ENTER key to register the setting.
To return to the selection screen of the setting items, press the \leftarrow or RETURN key. As an aid to setting or adjusting items, you can press the RESET key to return an item to its factory setting.

Using a pop-up menu

Press the $\uparrow/\downarrow/\leftarrow/\rightarrow$ key to select an item. A selected item takes effect immediately, except "Language", which will take effect after you press the ENTER key.

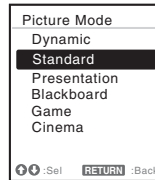

Using the setting menu

Press the \uparrow/\downarrow key to select the item. A selected item takes effect immediately. The previous screen is restored.

Using the adjustment menu

To increase the value, press the \uparrow/\rightarrow key and to decrease the number, press the \downarrow/\leftarrow key. If you press the ENTER key, the selected item takes effect immediately. The previous screen is restored.

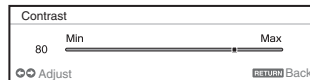

- 5 Press the MENU key to clear the menu.
The menu disappears automatically if no operation is performed.

The Picture Menu

The Picture is used to adjust the picture for each input signal.

| Items | Item descriptions |
|-----------------------------|---|
| Picture Mode | Dynamic: Emphasizes the contrast to produce a dynamic and vivid picture. Standard: Provides an image which is natural and well balanced. Presentation ^{*1} : Provides a bright image, suitable for presentations. Blackboard: Provides an image suitable for displaying on a blackboard. Game: Provides an image suitable for viewing games. Cinema: Provides an image suitable for viewing movies. |
| Reset ^{*2} | Resets to the factory setting. |
| Contrast | The higher the value, the greater the contrast. The lower the value, the lower the contrast. |
| Brightness | The higher the value, the brighter the picture. The lower the value, the darker the picture. |
| Color ^{*3 *4} | The higher the value, the greater the intensity. The lower the value, the lower the intensity. |
| Hue ^{*3 *4 *5} | The higher the value, the more greenish the picture becomes. The lower the value, the more reddish the picture becomes. |
| Color Temp. ^{*6} | High/Middle/Low: The higher the value, the more bluish the picture becomes. The lower the value, the more reddish the picture becomes. |
| Sharpness ^{*3} | The higher the value, the sharper the picture becomes. The lower the value, the softer the picture becomes. |
| Expert Setting | |
| Gamma Mode ^{*1 *7} | Graphics1: Gamma correction to make halftones brighter. This setting is suitable when projecting highly colorful images, such as photos, in a bright place. Graphics2: Gamma correction to improve the reproduction of halftones. Highly colorful images, such as photos, can be reproduced in natural tones. Text: Improves back and white contrast. Suitable for images with lots of text content. |

Notes

- *1: When a computer signal is input, this option is available.
- *2: The settings in the Picture return to their factory defaults, except for Picture Mode.
- *3: When a video signal is input, this option is available.
- *4: When the signal without color burst signal is input, this option is unavailable.
- *5: When an analog TV signal is input, this option may not available, depending on the color system.
- *6: When "Picture Mode" is set to the item other than "Presentation" or "Blackboard," this option is available.
- *7: When "Picture Mode" is set to "Blackboard," this option is unavailable.

The Screen Menu

The Screen menu is used to adjust the size, position and aspect ratio of the projected image for each input signal.

| Items | Item descriptions |
|---|--|
| Aspect ^{*1} | Changes the aspect ratio of the projected image (page 18). |
| VPL-DX140/DX120/DX100: When the computer signal is input | 4:3: Displays the image to fit the maximum projected image size with an aspect ratio fixed to 4:3. 16:9: Displays the image to fit the maximum projected image size with an aspect ratio fixed to 16:9. Full 1: Displays the image to fit the maximum projected image size without changing the aspect ratio of the input signal. Normal: Displays the image on the center position of the projected image without changing the resolution of the input signal or enlarging the image. |
| VPL-DX140/DX120/DX100: When the video signal is input | 4:3: Displays the image to fit the maximum projected image size with an aspect ratio fixed to 4:3. 16:9: Displays the image to fit the maximum projected image size with an aspect ratio fixed to 16:9. Zoom: Zooms the center area of a projected image. |
| VPL-DW120: When the computer signal is input | 4:3: Displays the image to fit the maximum projected image size with an aspect ratio fixed to 4:3. 16:9: Displays the image to fit the maximum projected image size with an aspect ratio fixed to 16:9. Full 1: Displays the image to fit the maximum projected image size without changing the aspect ratio of the input signal. Full 2: Displays the image to fit the maximum projected image size changing the aspect ratio of the input signal. Full 3: Displays the image to fit the maximum width or height, up to 1280 × 720 pixels, without changing the aspect ratio of the input signal. Normal: Displays the image on the center position of the projected image without changing the resolution of the input signal or enlarging the image. |
| VPL-DW120: When the video signal is input | 4:3: Displays the image to fit the maximum projected image size with an aspect ratio fixed to 4:3. 16:9: Displays the image to fit the maximum projected image size with an aspect ratio fixed to 16:9. Full^{*2}: Displays the image to fit the maximum projected image size changing the aspect ratio of the input signal. Zoom: Zooms the center area of a projected image. |



| Items | Item descriptions |
|----------------------|---|
| Adjust Signal | Adjusts the image of a computer signal. Use this item if the edge of the image is cut, or is not displayed properly. |
| APA ^{*2 *3} | Automatically adjusts the projected image to an optimum quality when you press the ENTER key (page 5). |
| Phase ^{*2} | Adjusts the dot phase of the display pixel and the input signal. Set to the value where looks clearest. |
| Pitch ^{*2} | The higher the value, the wider the horizontal image elements (pitch). The lower the value, the narrower the horizontal image elements (pitch). |
| Shift ^{*4} | H (Horizontal): The higher the value, the farther right the image is projected on the screen. The lower the value, the image farther left. V (Vertical): The higher the value, the farther up the image is projected on the screen. The lower the value, the image farther down. |

Notes

- *1: • Note that if the projector is used for profit or for public viewing, modifying the original picture by switching to the aspect mode may constitute an infringement of the rights of authors or producers, which are legally protected.
- Depending on the input signal, setting items for aspect ratio or some other setting items cannot be set in some cases, or changing the aspect ratio setting may have no effect.
- A part of the image may be displayed in black, depending on the setting item.
- *2: Available when a computer signal is input from the RGB input connector (INPUT A).
- *3: If the projected image includes large amount of black portion around it, the APA function will not work properly and a part of the image may not be displayed on the screen and also optimum image cannot be obtained, depending on the type of input signal. In this case, adjust the “Phase,” “Pitch,” and “Shift” items manually.
- *4: Available when a computer or a video signal is input from the RGB/YPbPr input connector.

Aspect

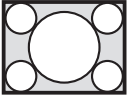
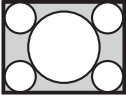
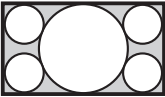
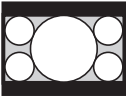
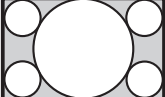
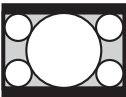
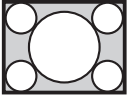
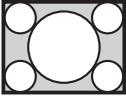
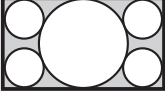
VPL-DX140/DX120/DX100

| | Input signal | Recommended setting value and projected image |
|-----------------|---|--|
| Computer signal | 4:3  | Full1 *1  |
| | 16:9  | Full1 *1 *2  |
| | 16:10  | Full1 *1 *2  |
| Video signal | 4:3  | 4:3 *3  |
| | 16:9  | 16:9 *4  |

*1: If you select “Normal,” the image is projected in the same resolution as the input signal without changing the aspect ratio of the original image.



*2: If you select “4:3,” the image is projected to fit the projected image size, regardless of the aspect ratio of the image.



*3: Depending on the input signal, the projected image may be projected as illustrated below. In this case, select “16:9.”



*4: Depending on the input signal, the projected image may be projected as illustrated below. In this case, select “Zoom.”

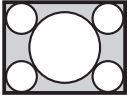
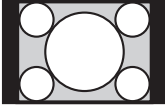
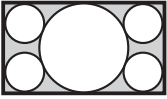
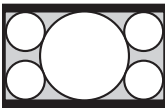
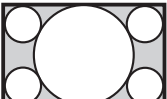
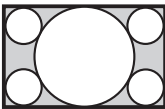
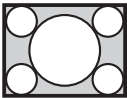
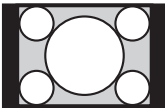
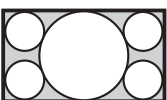
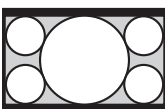

| | Input signal | Recommended setting value and projected image |
|-----------------|--|---|
| Computer signal | 4:3  | Full1 *1 *2 *3  |
| | 16:9  | Full1 *1 *2 *3  |
| | 16:10  | Full1 *3  |
| Video signal | 4:3  | 4:3 *4 *5  |
| | 16:9  | 16:9  |

*1: If you select “Normal,” the image is projected in the same resolution as the input signal without changing the aspect ratio of the original image.



*2: If you select “Full2,” the image is projected to fit the projected image size, regardless of the aspect ratio of the image.

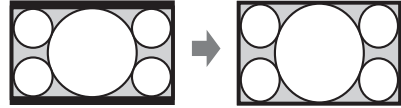

*3: If you adjust the projected image position using an image with 16:9 aspect ratio and then switch the input source to 4:3 image, the top and bottom edge of the image may be hidden. In this case, select “Full3.”



*4: Depending on the input signal, the projected image may be projected as illustrated below. In this case, select “16:9.”



*5: Depending on the input signal, the image may be projected as illustrated below. In this case, select “Zoom.”



The Function Menu

The Function menu is used for setting various functions of the projector.

| Items | Item descriptions |
|------------------|--|
| Volume | The higher the value, the louder an audio volume and the lower the value, the lower the audio volume. |
| Smart APA | On/Off: When set to “On,” APA functions automatically when a signal is input.* ¹ |
| CC Display | CC1/CC2/CC3/CC4/Text1/Text2/Text3/Text4: Select the closed caption service (captions or text). Off: Closed caption does not appear. |
| Lamp Timer Reset | When replacing the lamp, resets the lamp timer (page 29). |

Note

*1: APA functions when a computer signal is input via the RGB input connector (INPUT A).

The Operation Menu

The Operation menu is used for setting for the operations by using the menu or the remote commander.

| Items | Item descriptions |
|-----------------------------|--|
| Language | Selects the language used in the menu and messages. |
| Status | On: All on-screen statuses are enabled. Off: Turns off the on-screen displays, except for menus, warning messages and messages from the message list. |
| Security Lock ^{*1} | On/Off: This function enables restriction of the projector to authorized users by password. The setting procedures for security locking are as follows: <ol style="list-style-type: none">1 Select “On” and press the ENTER key to display the setting menu.2 Input the password with the MENU, $\uparrow/\downarrow/\leftarrow/\rightarrow$ and ENTER keys. (The default setting password is “ENTER, ENTER, ENTER, ENTER.”)3 Input a new password with the MENU, $\uparrow/\downarrow/\leftarrow/\rightarrow$ and ENTER keys.4 Enter the password again to confirm. Enter the password when you turn on the projector after disconnecting and reconnecting the AC power cord. When it is set to “Off,” you can cancel the security lock. You are required to input the password again. If you fail to enter the correct password after three consecutive times, the projector cannot be used. In this case, press the I/⏻ key to go Standby mode then turn on the power again. |
| Control Key Lock | On/Off: When set to “On,” locks all the control panel keys of the projector. However, you can operate the following when set to “On”: <ul style="list-style-type: none">• Press and hold the I/⏻ key for approximately 10 seconds during Standby mode. → The projector turns on.• Press and hold the MENU key for approximately 10 seconds during power on. → “Control Key Lock” is set to “Off” and enables operation of all keys on the projector. |

Note

*1: You will not be able to use the projector if you forget your password. If you call qualified Sony personnel because you have forgotten the password, you will be asked to verify the projector’s serial number and your identity. (This process may differ in other countries/regions.) Once your identity has been confirmed, we will provide you with the password.

The Connection/Power Menu

The Connection/Power menu is used for setting for the connections and power.

| Items | Item descriptions |
|---------------------|---|
| Input-A Signal Sel. | Auto/Computer/Video GBR/Component: When set to “Auto,” selects the type of video signal input automatically when “Input-A” is selected. *1 |
| ECO | |
| Lamp Mode | High/Standard/Low/Auto: When set to “High,” the image becomes brighter, and power consumption becomes higher. When set to “Low,” power consumption is minimized; however, the image will be darker. When set to “Auto,” brightness is adjusted automatically according to image content. When dark images are projected, lamp power consumption is reduced (to save energy), and luminance is adjusted, while bright images are projected without adjustment. |
| AUTO POWER SAVING | |
| With No Input | Lamp Cutoff: The lamp turns off automatically and power consumption is reduced if no signal is input for more than 10 minutes. The lamp lights again when a signal is input or any key is pressed. In Lamp Cutoff, the ON/STANDBY indicator lights in orange. (page 25) Standby *2: If no signal is input to the unit for more than 10 minutes, the power turns off automatically, and the unit enters standby mode. Off: You can deactivate the With No Input. |
| With Static Signal | Lamp Dimming: If an image does not change for about 10 seconds, lamp output is gradually reduced (approximately 10% to 15%*3) from that set in the Lamp Mode.*4 Automatically the lamp slowly darkens to approximately 30% of its lamp output according to the selected time (with no change to input signal) “5,” “10,” “15,” “20” minutes or “Demo.” While dimming the lamp, the message “Lamp Dimming” appears. If you select “Demo.,” the image will start to darken about 40 seconds later. When any change in signal is detected, or an operation (remote control or control panel) is performed, normal brightness is restored.*5 Off: You can deactivate the With Static Signal. |
| Direct Power On | On/Off: When set to “On,” you can turn the power on without going to Standby mode when the AC power cord is connected to a wall outlet. With the projector turned off, you can also unplug the AC power cord without going to Standby mode, regardless of the Direct Power On setting. |

Notes

- *1: This may not be optimum depending on the input signal. In this case, set manually according to the connected equipment.
- *2: Select “Off” to avoid entering standby mode when there is no input signal.
- *3: This varies depending on the “Lamp Mode” setting.
- *4: As the lamp is dimmed gradually, you may not notice any change in brightness. You might only notice that the lamp has dimmed when its brightness is restored after there is a change in input signal.
- *5: This mode does not work for about three minutes after the lamp lights. A change in signal may not be detected depending on the input image. The lamp may become brighter at intervals if you continue to use the projector during lamp dimming. However, this is not a malfunction. If With No Input is set, it takes priority.

The Installation Menu

The Installation menu is used for installing the projector.

| Items | Item descriptions |
|----------------------------------|---|
| Image Flip | HV/H/V/Off: Flips the projected image horizontally or vertically according to the installation method. |
| Installation Attitude | Right Side Up/Upside Down/Link to Image Flip: Change the cooling setting to suit to the installation attitude. When set to “Link to Image Flip,” the cooling setting changes based on the setting of “Image Flip.” Continuing to use the wrong setting may affect component reliability. |
| High Altitude Mode ^{*1} | On/Off: Set to “On” when using the projector at an altitude of 1,500 m or higher. Continuing to use the wrong setting may affect component reliability. |
| V keystone ^{*2} | Auto/Manual^{*2}: The higher the value, the narrower the top of the projected image. The lower the value, the narrower the bottom. |

Notes

- *1: When “High Altitude Mode” is set to “On,” the speed of the fan increases, and the fan noise becomes slightly louder.
- *2: Since the Keystone adjustment is an electronic correction, the image may be deteriorated.

The Information Menu

The Information menu is used to check projector status, such as total usage time of the lamp.

| Items | Item descriptions |
|---------------------|---|
| Model Name | Displays the model name. |
| Serial No. | Displays the serial number. |
| fH/fV ^{*1} | Displays the horizontal/vertical frequency of the current input signal. |
| Signal Type | Displays the type of the current input signal. |
| Lamp Timer | Indicates the total usage time of a lamp. |

Note

*1: These items may not be displayed depending on the input signal.

Indicators

The indicators allow checking the status and notify you of abnormal operation of the projector. If the projector exhibits abnormal status, address the problem in accordance with the table below.

ON/STANDBY indicator

| Status | Meaning/Remedies |
|-------------------------|--|
| Lights in red | The projector is in Standby mode. |
| Flashes in green | <ul style="list-style-type: none"> • The projector is ready to operate after having been turned on. • The lamp cools after the projector is turned off. |
| Lights in green | The projector's power is on. |
| Lights in orange | The projector is in With No Input (Lamp Cutoff). (page 22) |
| Flashes in red | The projector is in abnormal status. Symptoms are indicated by number of flashes. Address the problem in accordance with the following. If a symptom persists, despite having taken measures below, consult with qualified Sony personnel. |
| Flashes twice | <p>The internal temperature is unusually high. Check the items below.</p> <ul style="list-style-type: none"> • Check if nothing is blocking the ventilation holes. (pages 3, 3) • Check if the air filter is not clogged. (page 31) • Check if the Installation Attitude in the Installation menu is set correctly. (page 23) |
| Flashes six times | Unplug the AC power cord from a wall outlet. After checking that the ON/STANDBY indicator goes out, plug the power cord to a wall outlet again then turn on the projector. |
| Other number of flashes | Consult with qualified Sony personnel. |

LAMP/COVER indicator

| Status | Meaning/Remedies |
|---------------------|--|
| Flashes in red | Symptoms are indicated by number of flashes. Address the problem in accordance with the following. |
| Flashes twice | The lamp cover is not attached securely. (page 29) |
| Flashes three times | The temperature of lamp is unusually high. Turn off the power and wait for lamp to cool then turn on the power again. If the symptom is shown again, the lamp may be burnt out. In this case, replace the lamp with a new one (page 29). |

Messages List

When any of the messages listed below appears on the projected image, address the problem in accordance with the table below.

| Messages | Meaning/Remedy | Page |
|---|--|-----------------|
| High temp.! Lamp off in 1 min. | Check the items below. <ul style="list-style-type: none"> • Check if nothing is blocking the ventilation holes. • Check if the air filter is not clogged. • Check if the Installation Attitude in the Installation menu is set correctly. | 3, 3, 23, 31 |
| Frequency is out of range! | Change the output setting of the connected equipment to one for signals supported by the projector. | 36 |
| Please check Input-A Signal Sel. | Set “Input-A Signal Sel.” to “Auto” or select the input signal type to suit to the input signal. | 22 |
| Please clean the filter. | Clean the air filter. | 31 |
| Please replace the Lamp and clean the Filter. | Replace the lamp with a new one and clean the air filter. The message appears whenever you turn on the power until you replace the lamp and reset the lamp timer. | 29, 31 |
| Projector temperature is high. High Altitude Mode should be “On” if Projector is being used at high altitude. | When not using the projector at an altitude of 1,500 m or higher, check the items below. <ul style="list-style-type: none"> • Check if nothing is blocking the ventilation holes. • Check if the air filter is not clogged. • Check if Installation Attitude in the Installation menu is set correctly. | 3, 3, 23, 31 |
| Not applicable! | Invalid key was pressed. | – |
| The control keys are locked! | “Control Key Lock” is set to “On.” | 21 |
| Projector will shutdown soon Press I/⏻ Key to Restart | The I/⏻ key was pressed and the projector will be shut down soon. To cancel shutdown, press the I/⏻ key again (the projector will remain on). To turn off the projector directly, press and hold the I/⏻ key for a few seconds. | 13 |
| Lamp Dimming | Reduces lamp output when “With Static Signal” is set. When any change in signal is detected, or an operation (remote control or control panel) is performed, normal brightness is restored. | 22 |

Troubleshooting

Before asking to have the projector repaired, try to diagnose the problem, following the instructions below.

| Symptoms | Remedy | Page |
|--|--|-----------|
| The power is not turned on. | Check if the AC power cord is firmly connected. | – |
| | When the “Control Key Lock” is set to “On,” you cannot turn on the projector using the I/Ⓞ key on the projector. | 21 |
| | If the lamp or lamp cover is not attached securely, the projector cannot be turned on. | 29 |
| No image. | Check if the connecting cable is connected to external equipment firmly. | 7 |
| | Check the computer signal is set for output to an external monitor only. If you set your computer to output to both the computer’s display and an external monitor, the external monitor image may not be displayed properly. Set your computer to output to only an external monitor. | 9 |
| | Check if the input source is correctly selected. | 9 |
| | Check if the picture is muted. | 6 |
| On-screen display does not appear. | The on-screen display does not appear when “Status” in the Operation menu is set to “Off.” | 21 |
| The aspect ratio of the display is not right/the image is displayed smaller /a portion of image does not appear. | The image may not display correctly because the input signal cannot be judged correctly. In this case, set “Aspect” manually. | 5, 16, 18 |
| The image is a trapezoid. | The images become trapezoidal because of the projection angle. In this case, you can correct the trapezoidal distortion, using a Keystone feature. | 5, 12, 23 |
| | When the “V Keystone” is set to “Manual,” the keystone feature does not work automatically. Set “V Keystone” to “Auto” or “Manual” to set manually. | 5, 12, 23 |
| | When the projector is installed on an uneven surface, the feature may not work properly. In this case, select “Manual” to set “V Keystone” manually. | 5, 12, 23 |

| Symptoms | Remedy | Page |
|---------------------------------------|--|--------|
| The image is dark/too bright. | The settings for “Brightness,” “Contrast,” and “Lamp Mode” affect brightness of the image. Check if the value is appropriate. | 15, 22 |
| | The image will be dark when the lamp is burnt out. Check “Lamp Timer,” and replace the lamp with a new one if necessary. | 24, 29 |
| | “With Static Signal” is set to “On.” | 22 |
| | During picture muting, the lamp is dimmed to reduce power consumption. | 22 |
| | When video signal is not input, the lamp is dimmed to reduce power consumption. | – |
| The image becomes darker or brighter. | When the lamp is dimmed for a long time, brightness may increase temporarily, but this is not malfunction. | – |
| | When the “Lamp Mode” is set to “Auto,” the luminance of the lamp changes according to the input image. | 22 |
| The image is not clear. | Check if the projector is in focus. | 10 |
| | The picture will not be clear if condensation has accumulated on the lens. In this case, let the projector sit for about two hours with the power on. | – |
| The image is noisy. | Check if the connecting cable is connected to the external equipment properly. | 7 |
| No sound. | Check that the connecting cables between the projector and external video or audio equipment are securely connected. | 7 |
| | Check if the external audio equipment is set properly. | – |
| | Audio is not output if audio muting is activated. | 6 |
| | Check if the volume is not set to minimum. | 6, 20 |
| The remote commander does not work. | Check if the batteries are installed correctly. | – |
| | Check if the batteries are not exhausted. | – |
| The fan is noisy. | The sound from the fan is often greater than normal to cool the lamp, etc. in the following cases. <ul style="list-style-type: none"> • “Lamp Mode” is set to “High.” • The unit is used at a high altitude. “High Altitude Mode” is set to “On.” • The unit is used in the location where the temperature is high. | 22, 23 |
| | If the ventilation holes are blocked, the internal temperature of the projector rises and the fan noise becomes larger. | 3, 3 |

Replacing the Lamp

Replace the lamp with a new one if a message displayed on the projected image (page 26). Use an LMP-D213 projector lamp (not supplied) for replacement.

Caution

- The lamp remains hot after the projector is turned off. **If you touch the lamp, you may burn your finger. When you replace the lamp, wait for at least an hour after turning off the projector for the lamp to cool sufficiently.**
- Do not allow any metallic or inflammable objects into the lamp replacement slot after removing the lamp, otherwise it may cause electrical shock or fire. Do not put your hands into the slot.

Notes

- **If the lamp breaks, contact qualified Sony personnel. Do not replace the lamp yourself.**
- When removing the lamp, be sure to pull it out straight, by holding the designated location. If you touch a part of the lamp other than the designated location, you may be burned or injured. If you pull out the lamp while the projector is tilted, the pieces may scatter if the lamp breaks any may cause injury.

- 1 Turn off the projector, and disconnect the AC power cord from a wall outlet.
- 2 When the lamp has cooled sufficiently, open the lamp cover by loosening one screw.

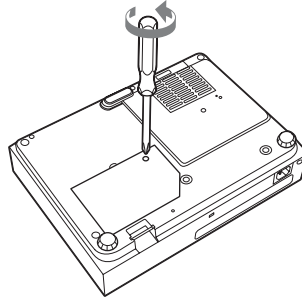

Note

For safety reasons, do not loosen any other screws.

- 3 Loosen the two screws on the lamp unit (1). Fold out the handle (2), then pull out the lamp unit by the handle (3).

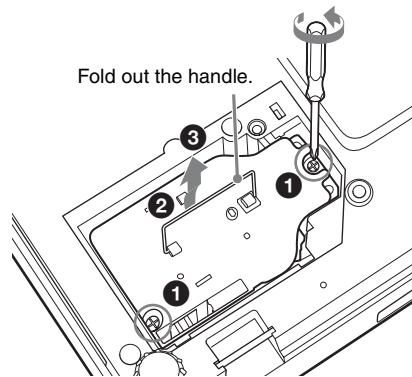

Caution

Do not put your hands into the lamp replacement slot, and do not allow any liquid or other objects into the slot to **avoid electrical shock or fire**.

- 4 Insert the new lamp all the way in until it is securely in place (1). Tighten the two screws (2). Fold down the handle to replace it (3).

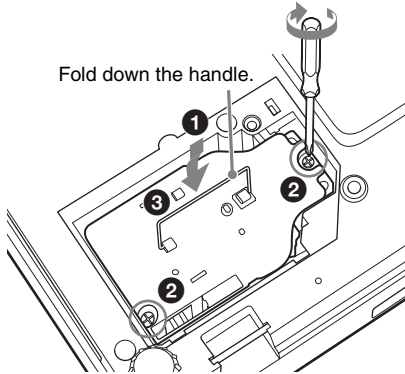

Notes

- Be careful not to touch the glass surface of the lamp and a inside conductor.
- Insert the handle firmly to attach it securely.
- The power will not turn on if the lamp is not secured properly.

- 5 Close the lamp cover and tighten the 1 screw.

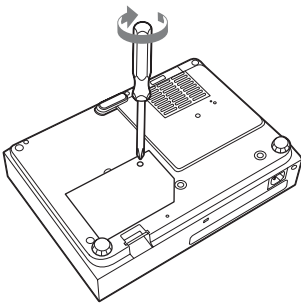

- 6 Connect the AC power cord to a wall outlet and turn on the projector.
- 7 Reset the lamp timer for notification of the next replacement time.
Select “Lamp Timer Reset” on the Function menu then press the ENTER key. When a message appears, select “Yes” to reset the lamp timer (page 20).

Caution

Disposal of the used lamp For the customers in the USA

Lamp in this product contains mercury. Disposal of these materials may be regulated due to environmental considerations. For disposal or recycling information, please contact your local authorities or the Telecommunications Industry Association (www.eiae.org).

Cleaning the Air Filter

When a message appears on the projected image indicating time for a filter cleaning, clean the air filter (page 26).

If the dust cannot be removed from the air filter even after cleaning, replace the air filter with a new one. For details on purchasing/fitting a new air filter, consult with the store where you purchased the projector, or contact qualified Sony personnel.

Caution

If you neglect to clean the air filter, dust may accumulate, clogging it. As a result, the temperature may rise inside the unit, leading to a possible malfunction or fire.

- 1 Turn off the projector, and disconnect the AC power cord from the AC outlet.
- 2 Slide out and remove the air filter cover from the unit.
- 3 Clean the air filter with a vacuum cleaner. Pull out and remove the air filter cover, and clean it with a vacuum cleaner.

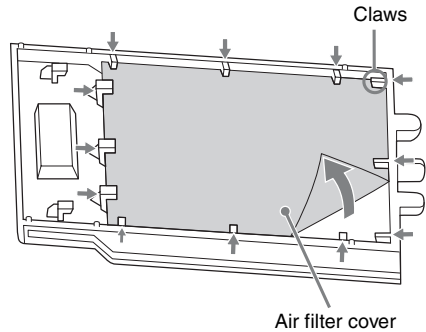
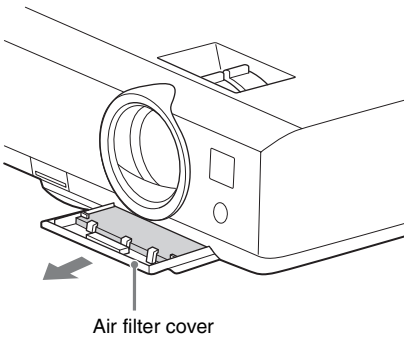

- 4 Reattach the air filter cover to the unit.

Specifications

| Items | | Descriptions |
|---|---------------------------------|--|
| Model | | VPL-DX140/DX120/DX100/VPL-DW120 |
| Projection system | | 3 LCD system |
| Display device | Effective display size | VPL-DX140/DX120/DX100: 0.63 inch (16.0 mm), 3 plate panels, Aspect ratio 4:3 VPL-DW120: 0.59 inch (15.0 mm), 3 plate panels, Aspect ratio 16:10 |
| | Effective picture elements | VPL-DX140/DX120/DX100: 2,359,296 pixels (1024 × 768 pixels, 3 plate panels) VPL-DW120: 3,072,000 pixels (1280 × 800 pixels, 3 plate panels) |
| Projection lens | Zoom | Manual zoom: VPL-DX140/VPL-DW120: approx.1.3 times VPL-DX120/DX100: approx.1.2 times |
| | Focus | Manual |
| Light source | | High-pressure mercury lamp, 210 W type |
| Projected image size | | 30 inches to 300 inches (0.76 m to 7.62 m) |
| Luminous flux (Brightness) | | VPL-DX140: 3200 lm VPL-DX120/VPL-DW120: 2600 lm VPL-DX100: 2300 lm (when “Lamp Mode” is set to “High”) |
| Speaker | | 1 W × 1 (monaural) |
| Applicable scanning frequency ^{*1} | | Horizontal: 15 kHz to 92 kHz, Vertical: 48 Hz to 92 Hz |
| Resolution ^{*1} | When a computer signal is input | Maximum display resolution: 1600 × 1200 pixels (resize) Panel display resolution: VPL-DX140/DX120/DX100: 1024 × 768 pixels VPL-DW120: 1280 × 800 pixels |
| | When a video signal is input | NTSC, PAL, SECAM, 480/60i, 576/50i, 480/60p, 576/50p, 720/60p, 720/50p, 1080/60i, 1080/50i, 1080/60p, 1080/50p |
| Color system | | NTSC ^{3.58} , PAL, SECAM, NTSC ^{4.43} , PAL-M, PAL-N |

| Items | Descriptions |
|--|---|
| Model | VPL-DX140/DX120/DX100/VPL-DW120 |
| INPUT OUTPUT (Computer/video) | INPUT A RGB/YPbPr input connector: Mini D-sub 15 pin female, G with sync/Y: 1 V _{p-p} ± 2 dB, sync negative, 75 ohms terminated, RGB/PbPr: 0.7 V _{p-p} ± 2 dB, 75 ohms terminated, Sync signal: TTL level high impedance, positive/negative Audio input connector: Stereo mini jack, rated input 500 mV _{rms} , input impedance more than 47 kohms |
| | INPUT B HDMI input connector: HDMI 19-pin, HDCP, HDMI audio support |
| | VIDEO Video input connector: Pin jack, 1 V _{p-p} ± 2 dB, sync negative, 75 ohms terminated Audio input connector: Shared with INPUT A |
| Operating temperature/ Operating humidity | 0 °C to 35 °C (32 °F to 95 °F)/35% ~ 85% (no condensation) |
| Storage temperature/ Storage humidity | -10 °C to +60 °C (14 °F to 140 °F)/10% to 90% (no condensation) |
| Power requirements | 100V to 240V AC, 2.9 - 1.2 A, 50/60Hz |
| Power consumption | 100V to 120V AC: 290W 220V to 240V AC: 280W |
| Standby power | 0.5 W |
| Heat dissipation | 100V AC: 990BTU 240V AC: 955BTU |
| Standard dimensions (W/H/D) | Approx. 315 × 87.2 × 233 mm (12 ¹³ / ₃₂ × 3 ⁷ / ₁₆ × 9 ³ / ₁₆ inches) Approx. 315 × 75 × 230.5 mm (12 ¹³ / ₃₂ × 2 ¹⁵ / ₁₆ × 9 ¹ / ₁₆ inches) (without projecting parts) |
| Mass | Approx. 2.5 kg (5 lb 7 oz) |
| Supplied accessories | See “Checking the Supplied Accessories” in the supplied Quick Reference Manual. |
| Optional accessories *2 *3 | Projector Lamp LMP-D213 (for replacement) |

Notes

*1: For details, refer to “Acceptable Input Signals*1” on page 36.

*2: Information on accessories in this manual is current as of June 2012.

*3: Not all optional accessories are available in all countries and area. Please check with your local Sony Authorized Dealer.

Design and specifications of the unit, including the optional accessories, are subject to change without notice.

Always verify that the unit is operating properly before use. SONY WILL NOT BE LIABLE FOR DAMAGES OF ANY KIND INCLUDING, BUT NOT LIMITED TO, COMPENSATION OR REIMBURSEMENT ON ACCOUNT OF THE LOSS OF PRESENT OR PROSPECTIVE PROFITS DUE TO FAILURE OF THIS UNIT, EITHER DURING THE WARRANTY PERIOD OR AFTER EXPIRATION OF THE WARRANTY, OR FOR ANY OTHER REASON WHATSOEVER.

Pin assignment

HDMI connector (HDMI, female)

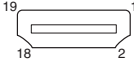

| | | | |
|----|-----------------------|----|-----------------------|
| 1 | T.M.D.S. Data2+ | 11 | T.M.D.S. Clock Shield |
| 2 | T.M.D.S. Data2 Shield | 12 | T.M.D.S. Clock - |
| 3 | T.M.D.S. Data2 - | 13 | N.C. |
| 4 | T.M.D.S. Data1+ | 14 | RESERVED (N.C.) |
| 5 | T.M.D.S. Data1 Shield | 15 | SCL |
| 6 | T.M.D.S. Data1 - | 16 | SDA |
| 7 | T.M.D.S. Data0+ | 17 | DDC GND |
| 8 | T.M.D.S. Data0 Shield | 18 | +5V Power |
| 9 | T.M.D.S. Data0 - | 19 | Hot Plug Detect |
| 10 | T.M.D.S. Clock+ | | |

RGB input connector (Mini D-sub 15-pin, female)

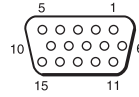

| | | | |
|---|-----------------------|----|----------------------------|
| 1 | Video input (red) R | 9 | Power supply input for DDC |
| 2 | Video input (green) G | 10 | GND |
| 3 | Video input (blue) B | 11 | GND |
| 4 | GND | 12 | DDC/SDA |
| 5 | RESERVE | 13 | Horizontal sync signal |
| 6 | GND (R) | 14 | Vertical sync signal |
| 7 | GND (G) | 15 | DDC/SCL |
| 8 | GND (B) | | |

Acceptable Input Signals*1

Computer signal

| Resolution | fH[kHz]/ fV[Hz] | Input connector | |
|-------------|--------------------|-----------------|------|
| | | RGB/ YPbPr | HDMI |
| 640 × 350 | 31.5/70 | ● | |
| | 37.9/85 | ● | |
| 640 × 400 | 31.5/70 | ● | |
| | 37.9/85 | ● | |
| 640 × 480 | 31.5/60 | ● | ● |
| | 35.0/67 | ● | |
| | 37.9/73 | ● | |
| | 37.5/75 | ● | |
| | 43.3/85 | ● | |
| 800 × 600 | 35.2/56 | ● | |
| | 37.9/60 | ● | ● |
| | 48.1/72 | ● | |
| | 46.9/75 | ● | |
| | 53.7/85 | ● | |
| 832 × 624 | 49.7/75 | ● | |
| 1024 × 768 | 48.4/60 | ● | ● |
| | 56.5/70 | ● | |
| | 60.0/75 | ● | |
| | 68.7/85 | ● | |
| 1152 × 864 | 64.0/70 | ● | |
| | 67.5/75 | ● | |
| | 77.5/85 | ● | |
| 1152 × 900 | 61.8/66 | ● | |
| 1280 × 960 | 60.0/60 | ● | ● |
| 1280 × 1024 | 64.0/60 | ● | ● |
| | 80.0/75 | ● | |
| | 91.1/85 | ● | |
| 1400 × 1050 | 65.3/60 | ● | ● |
| 1600 × 1200 | 75.0/60 | ● | ● |
| 1280 × 768 | 47.8/60 | | ● |
| 1280 × 720 | 45.0/60 | ● | ●*2 |
| 1920 × 1080 | 67.5/60 | | ●*3 |
| 1366 × 768 | 47.7/60 | ● | ● |
| 1440 × 900 | 55.9/60 | ● | ● |

| Resolution | fH[kHz]/ fV[Hz] | Input connector | |
|------------|--------------------|-----------------|------|
| | | RGB/ YPbPr | HDMI |
| 1280 × 800 | 49.7/60 | ● | ● |

Digital TV signal

| Signal | fV[Hz] | Input connector | |
|--------|--------|-----------------|------|
| | | RGB/ YPbPr | HDMI |
| 480i | 60 | ● | ● |
| 576i | 50 | ● | ● |
| 480p | 60 | ● | ● |
| 576p | 50 | ● | ● |
| 1080i | 60 | ● | ● |
| 1080i | 50 | ● | ● |
| 720p | 60 | ● | ● |
| 720p | 50 | ● | ● |
| 1080p | 60 | | ● |
| 1080p | 50 | | ● |

Analog TV signal

| Signal | fV[Hz] | Input connector |
|-----------|--------|-----------------|
| | | VIDEO |
| NTSC | 60 | ● |
| PAL/SECAM | 50 | ● |

Notes

- *1: ● When a signal other than the signals listed in table is input, the picture may not be displayed properly.
- An input signal meant for screen resolution different from that of the panel will not be displayed in its original resolution. Text and lines may be uneven.
- *2: This is identified as a movie delivery signal of 720/60p.
- *3: This is identified as a movie delivery signal of 1080/60p.

Projection Distance

The projection distance is the distance between the front of the lens and the surface of the projected image. The following describes the projection distance and height from the front of the lens to edge of screen by each projected screen size. Height H is the height from the bottom of the projected image (top for ceiling mount) to A (determined by drawing a perpendicular line from the front of the lens to projected image surface).

Caution

Never mount the projector on the ceiling or move it by yourself. Be sure to consult with qualified Sony personnel (charged).

Floor Installation

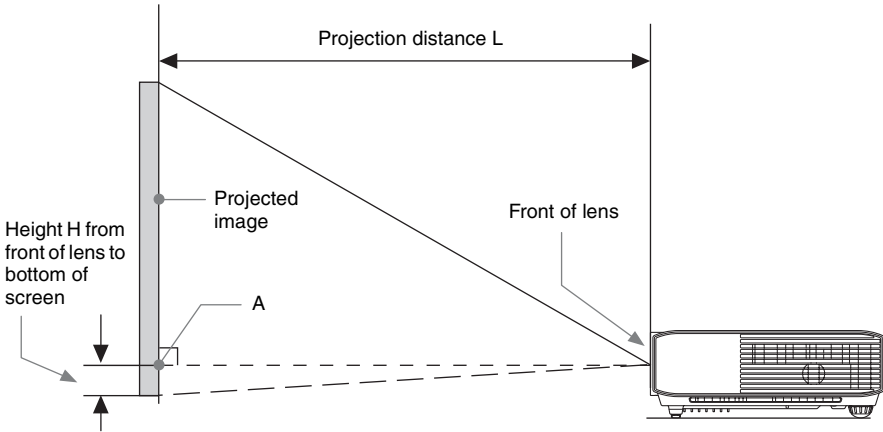

Ceiling Installation

Height H from front of lens to top of screen

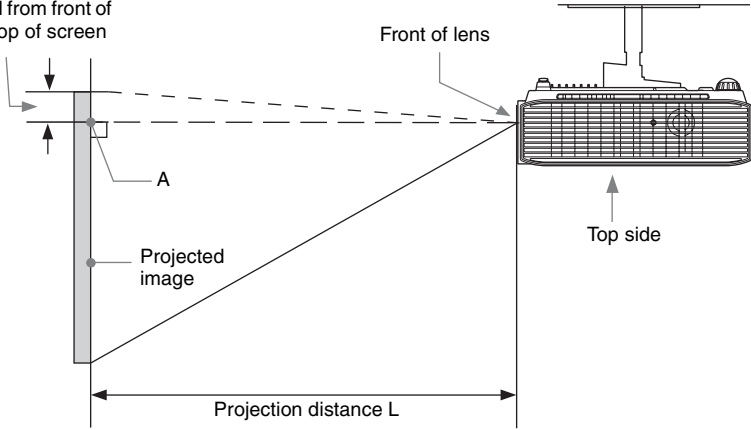

L: Projection distance L

H: Distance between the bottom edge of the image and the center of the lens

Projection distance table (VPL-DX140)

Unit: m (inches)

| Projected image size | | Projection Distance L | Height H from center of lens to bottom of screen | |
|----------------------|----------------------------|-----------------------|--|-------------------------------|
| Diagonal D | Width × Height | | Minimum Projection Distance L | Maximum Projection Distance L |
| 80 inch (2.03 m) | 1.63 × 1.22 (64 × 48) | 2.25-2.92 (89-115) | -0.20 (-8) | -0.20 (-8) |
| 100 inch (2.54 m) | 2.03 × 1.52 (80 × 60) | 2.81-3.66 (111-144) | -0.25 (-10) | -0.25 (-10) |
| 120 inch (3.05 m) | 2.44 × 1.83 (96 × 72) | 3.38-4.40 (133-173) | -0.30 (-12) | -0.30 (-12) |
| 150 inch (3.81 m) | 3.05 × 2.29 (120 × 90) | 4.23-5.51 (167-217) | -0.38 (-15) | -0.38 (-15) |
| 200 inch (5.08 m) | 4.06 × 3.05 (160 × 120) | 5.65-7.36 (223-289) | -0.51 (-20) | -0.51 (-20) |

Projection distance formula (VPL-DX140)

D: Projected image size (Diagonal)

H: Distance between the bottom edge of the image and the center of the lens

Expression#1

Unit: m (inches)

| Minimum Projection Distance L | Maximum Projection Distance L |
|--|--|
| $L=0.028366 \times D-0.0290$ ($L=1.116781 \times D-1.1416$) | $L=0.036956 \times D-0.0283$ ($L=1.454972 \times D-1.1124$) |

Expression#2

| Height H from lens center to bottom of screen | |
|--|--|
| Minimum Projection Distance L | Maximum Projection Distance L |
| $H=-0.00254 \times D+0.00000$ ($H=-0.10000 \times D+0.00000$) | $H=-0.00254 \times D+0.00000$ ($H=-0.10000 \times D+0.00000$) |

Others

Projection distance table (VPL-DX120/DX100)

Unit: m (inches)

| Projected image size | | Projection Distance L | Height H from center of lens to bottom of screen | |
|----------------------|----------------------------|-----------------------|--|-------------------------------|
| Diagonal D | Width × Height | | Minimum Projection Distance L | Maximum Projection Distance L |
| 80 inch (2.03 m) | 1.63 × 1.22 (64 × 48) | 2.42-2.88 (95-113) | -0.20 (-8) | -0.20 (-8) |
| 100 inch (2.54 m) | 2.03 × 1.52 (80 × 60) | 3.02-3.60 (119-141) | -0.25 (-10) | -0.25 (-10) |
| 120 inch (3.05 m) | 2.44 × 1.83 (96 × 72) | 3.63-4.33 (143-170) | -0.30 (-12) | -0.30 (-12) |
| 150 inch (3.81 m) | 3.05 × 2.29 (120 × 90) | 4.55-5.42 (179-213) | -0.38 (-15) | -0.38 (-15) |
| 200 inch (5.08 m) | 4.06 × 3.05 (160 × 120) | 6.07-7.23 (239-284) | -0.51 (-20) | -0.51 (-20) |

Projection distance formula (VPL-DX120/DX100)

D: Projected image size (Diagonal)

H: Distance between the bottom edge of the image and the center of the lens

Expression#1

Unit: m (inches)

| Minimum Projection Distance L | Maximum Projection Distance L |
|--|--|
| $L=0.030427 \times D-0.0234$ ($L=1.197898 \times D-0.9193$) | $L=0.036301 \times D-0.0236$ ($L=1.429177 \times D-0.9283$) |

Expression#2

| Height H from lens center to bottom of screen | |
|--|--|
| Minimum Projection Distance L | Maximum Projection Distance L |
| $H=-0.00254 \times D+0.00000$ ($H=-0.10000 \times D+0.00000$) | $H=-0.00254 \times D+0.00000$ ($H=-0.10000 \times D+0.00000$) |

Projection distance table (VPL-DW120)

Unit: m (inches)

| Projected image size | | Projection Distance L | Height H from center of lens to bottom of screen | |
|----------------------|----------------------------|-----------------------|--|-------------------------------|
| Diagonal D | Width × Height | | Minimum Projection Distance L | Maximum Projection Distance L |
| 80 inch (2.03 m) | 1.72 × 1.08 (68 × 42) | 2.36-3.05 (93-120) | -0.20 (-8) | -0.20 (-8) |
| 100 inch (2.54 m) | 2.15 × 1.35 (85 × 53) | 2.95-3.82 (117-150) | -0.25 (-10) | -0.25 (-10) |
| 120 inch (3.05 m) | 2.58 × 1.62 (102 × 64) | 3.55-4.59 (140-180) | -0.29 (-12) | -0.29 (-12) |
| 150 inch (3.81 m) | 3.23 × 2.02 (127 × 79) | 4.44-5.75 (175-226) | -0.37 (-15) | -0.37 (-15) |
| 200 inch (5.08 m) | 4.31 × 2.69 (170 × 106) | 5.93-7.67 (234-302) | -0.49 (-19) | -0.49 (-19) |

Projection distance formula (VPL-DW120)

D: Projected image size (Diagonal)

H: Distance between the bottom edge of the image and the center of the lens

Expression#1

Unit: m (inches)

| Minimum Projection Distance L | Maximum Projection Distance L |
|--|--|
| $L=0.029757 \times D-0.0291$ ($L=1.171525 \times D-1.1450$) | $L=0.038536 \times D-0.0282$ ($L=1.517164 \times D-1.1091$) |

Expression#2

| Height H from lens center to bottom of screen | |
|--|--|
| Minimum Projection Distance L | Maximum Projection Distance L |
| $H=-0.00246 \times D+0.00000$ ($H=-0.09675 \times D+0.00000$) | $H=-0.00246 \times D+0.00000$ ($H=-0.09675 \times D+0.00000$) |

Others

Dimensions

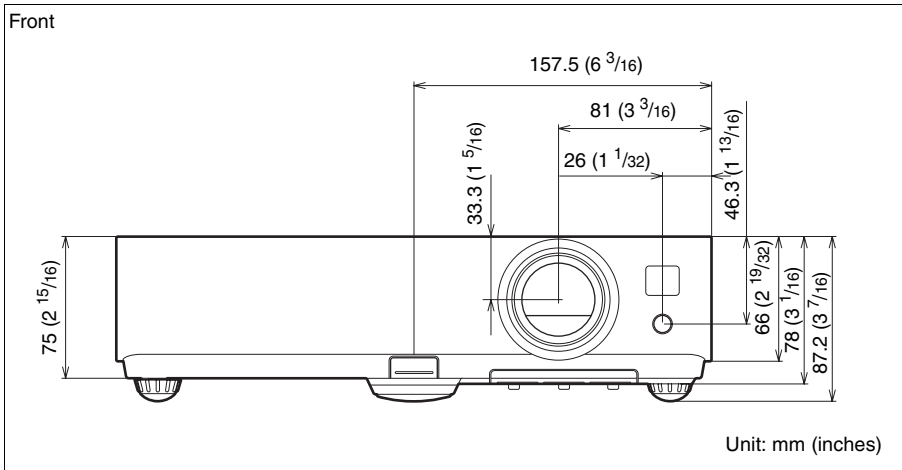
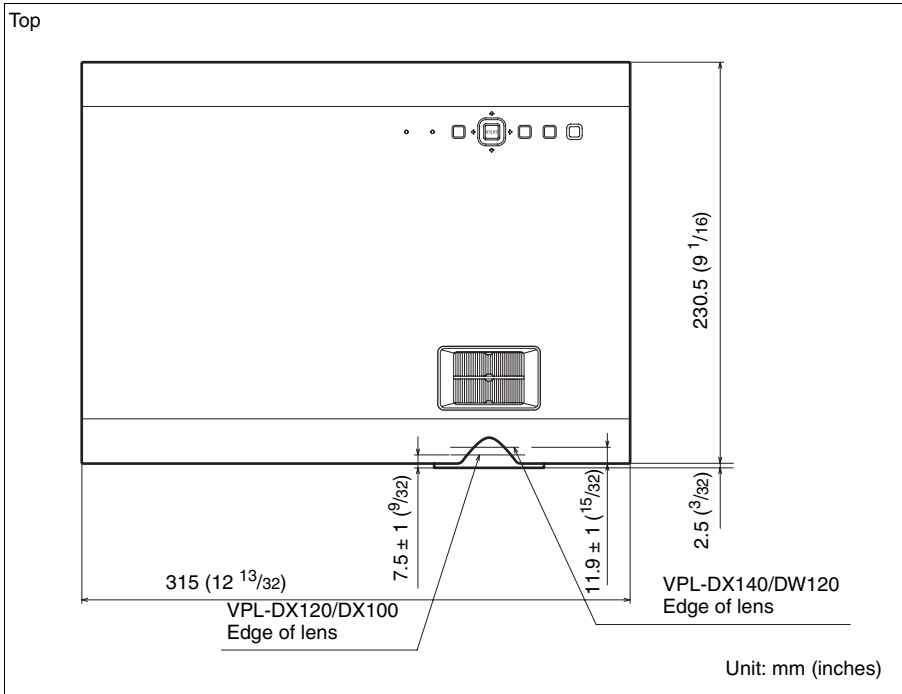

Side

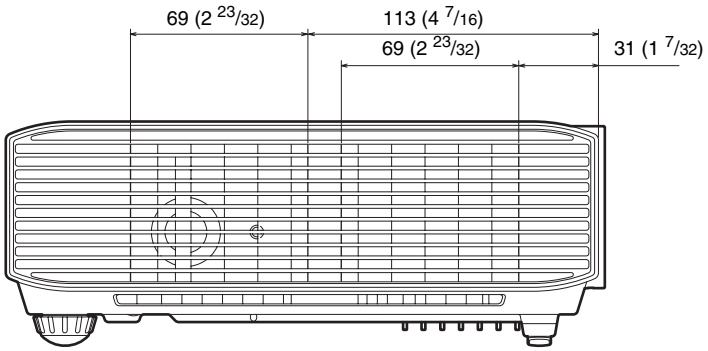

Unit: mm (inches)

Rear

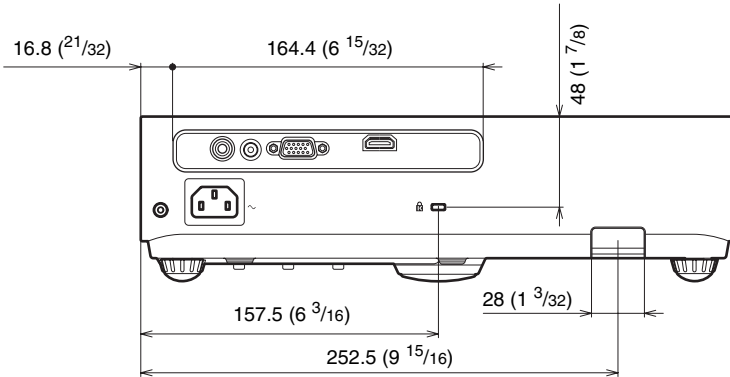

Unit: mm (inches)

Others

Bottom

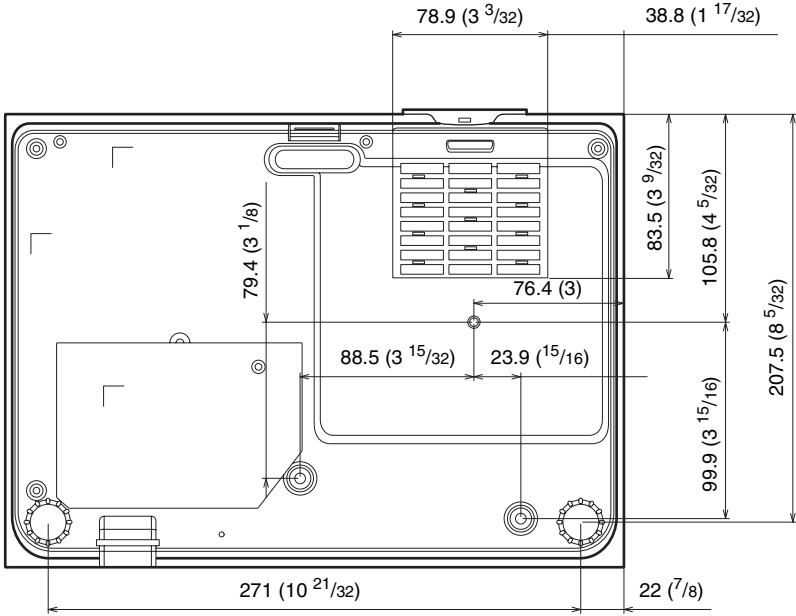

Unit: mm (inches)

Index

A

| | |
|--|-----------|
| AC IN | 4 |
| Acceptable input signal | 36 |
| Adjust Signal | 17 |
| Adjuster | 3, 11 |
| Air filter | 31 |
| Air filter cover/Ventilation holes (intake) | 3 |
| APA | 5 |
| Aspect | 5, 16, 18 |
| Audio muting | 6 |

B

| | |
|------------------|----|
| Brightness | 15 |
|------------------|----|

C

| | |
|---|-------|
| CC Display | 20 |
| Color | 15 |
| Color Temp. | 15 |
| Connecting a computer | 7 |
| Connecting a Video equipment | 8 |
| Connector panel | 3, 4 |
| Contrast | 15 |
| Control Key Lock | 21 |
| Control Panel Keys | 5 |
| Correcting trapezoidal distortion of the projected image (Keystone feature) | 5, 12 |

D

| | |
|--------------------|---|
| Digital Zoom | 5 |
|--------------------|---|

E

| | |
|-------------------------------------|---|
| ECO MODE (Energy-saving mode) | 6 |
|-------------------------------------|---|

F

| | |
|------------------|----|
| fH | 24 |
| Focus | 10 |
| Focus ring | 3 |
| Freeze | 6 |
| fV | 24 |

G

| | |
|------------------|----|
| Gamma Mode | 15 |
|------------------|----|

H

| | |
|--------------------------|----|
| H (Horizontal) | 17 |
| High Altitude Mode | 23 |
| Hue | 15 |

I

| | |
|-------------------------|----|
| Image Flip | 23 |
| Information menu | 24 |
| Input | 4 |
| Installation menu | 23 |

K

| | |
|----------------|---|
| Keystone | 5 |
|----------------|---|

L

| | |
|---|-------|
| Lamp cover | 3 |
| Lamp Timer | 24 |
| Lamp Timer Reset | 20 |
| LAMP/COVER indicator | 3, 25 |
| Language | 21 |
| Link to Image Flip | 23 |
| Location and function of controls | 3 |

M

| | |
|---------------------|----|
| Main unit | 3 |
| Messages list | 26 |
| Model Name | 24 |

O

| | |
|----------------------------|----|
| Operation menu | 21 |
| Optional accessories | 33 |

P

| | |
|---------------------------|----|
| Phase, Pitch, Shift | 17 |
| Picture menu | 15 |
| Picture mode | 15 |
| Picture muting | 6 |
| Pin assignment | 35 |
| Projecting an image | 9 |
| Projection distance | 37 |

R

| | |
|-------------------------------|----|
| Remote commander | 5 |
| Remote control detector | 3 |
| Replacing the lamp | 29 |
| Reset | 15 |

S

| | |
|---------------------------------|-------|
| Security bar | 3 |
| Security Lock | 3, 21 |
| Selecting an input signal | 5 |
| Serial No. | 24 |
| Sharpness | 15 |
| Signal Type | 24 |
| Smart APA | 20 |
| Specifications | 32 |
| Status | 21 |

T

| | |
|---------------------------------|-------|
| The Connection/Power Menu | 22 |
| The Function menu | 20 |
| The Screen menu | 16 |
| Troubleshooting | 27 |
| Turn off | 5, 13 |
| Turn on | 5, 9 |

U

| | |
|--------------------|----|
| Using a menu | 14 |
|--------------------|----|

V

| | |
|-------------------------|-----------|
| V Keystone | 5, 12, 23 |
| Ventilation holes | 3 |
| Volume | 6 |

W

| | |
|--------------------------|----|
| With No Input | 22 |
| With Static Signal | 22 |

Z

| | |
|------------|----|
| Zoom | 10 |
|------------|----|

About Trademarks

- Adobe and Adobe Acrobat are trademarks or registered trademarks of Adobe Systems Incorporated in the United States and/or other countries.
- Kensington is a registered trademark of Kensington Technology Group.
- The terms HDMI and HDMI High-Definition Multimedia Interface, and the HDMI Logo are trademarks or registered trademarks of HDMI Licensing LLC in the United States and other countries.
- All other trademarks and registered trademarks are trademarks or registered trademarks of their respective holders. In this manual, [™] and [®] marks are not specified.

