

SHARP®

XV-Z17000

PROJECTOR
PROJECTEUR
PROYECTOR
PROJETOR

OPERATION MANUAL
MODE D'EMPLOI
MANUAL DE MANEJO
MANUAL DE OPERAÇÃO

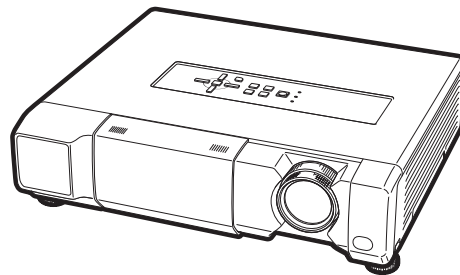
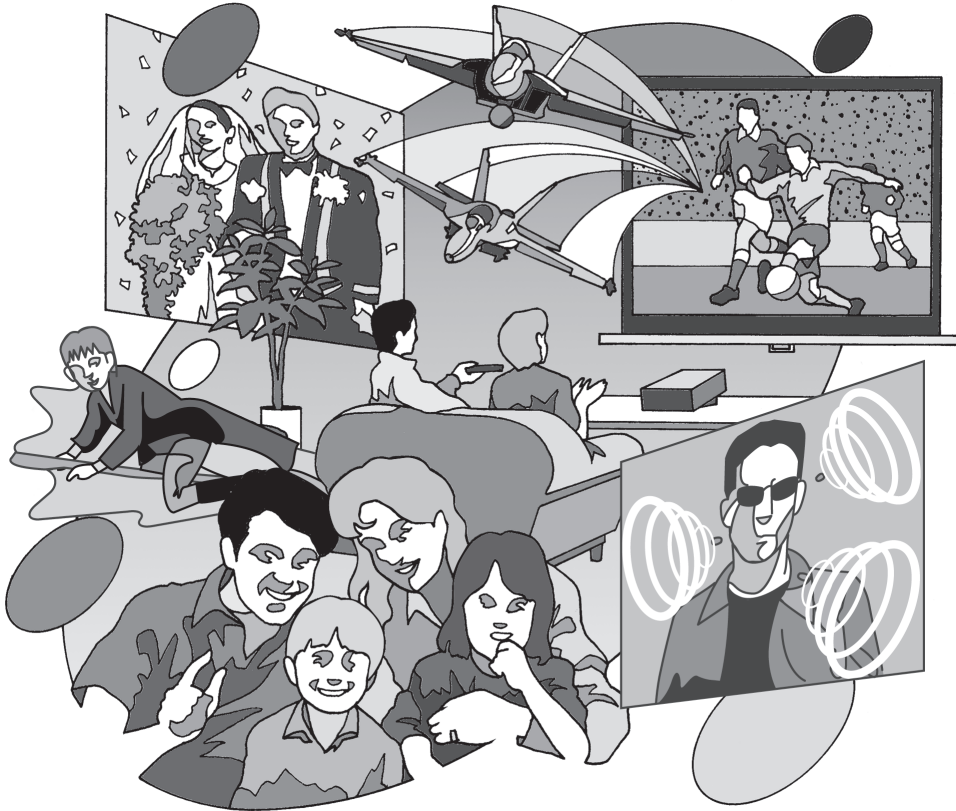

3D



HDMI™
HIGH-DEFINITION MULTIMEDIA INTERFACE



ENGLISH

FRANÇAIS

ESPAÑOL

PORTUGUÊS

SPECIAL NOTE FOR USERS IN THE U.K.

The mains lead of this product is fitted with a non-rewireable (moulded) plug incorporating a 10A fuse. Should the fuse need to be replaced, a BSI or ASTA approved BS 1362 fuse marked  or  and of the same rating as above, which is also indicated on the pin face of the plug, must be used. Always refit the fuse cover after replacing the fuse. Never use the plug without the fuse cover fitted. In the unlikely event of the socket outlet in your home not being compatible with the plug supplied, cut off the mains plug and fit an appropriate type.

DANGER:

The fuse from the cut-off plug should be removed and the cut-off plug destroyed immediately and disposed of in a safe manner.

Under no circumstances should the cut-off plug be inserted elsewhere into a 13A socket outlet, as a serious electric shock may occur.

To fit an appropriate plug to the mains lead, follow the instructions below:

WARNING:

THIS APPARATUS MUST BE EARTHED.

IMPORTANT:

The wires in this mains lead are coloured in accordance with the following code:

Green-and-yellow	:	Earth
Blue	:	Neutral
Brown	:	Live

As the colours of the wires in the mains lead of this apparatus may not correspond with the coloured markings identifying the terminals in your plug proceed as follows:

- The wire which is coloured green-and-yellow must be connected to the terminal in the plug which is marked by the letter E or by the safety earth symbol  or coloured green or green-and-yellow.
- The wire which is coloured blue must be connected to the terminal which is marked with the letter N or coloured black.
- The wire which is coloured brown must be connected to the terminal which is marked with the letter L or coloured red.

IF YOU HAVE ANY DOUBT, CONSULT A QUALIFIED ELECTRICIAN.

Before using the projector, please read this operation manual carefully.

Introduction

IMPORTANT

- For your assistance in reporting the loss or theft of your Projector, please record the Serial Number located on the bottom of the projector and retain this information.
- Before recycling the packaging, please ensure that you have checked the contents of the carton thoroughly against the list of “Supplied accessories” on page 9.

Model No.: XV-Z17000



Serial No.:

WARNING: High brightness light source. Do not stare into the beam of light, or view directly. Be especially careful that children do not stare directly into the beam of light.



WARNING: To reduce the risk of fire or electric shock, do not expose this product to rain or moisture.

See bottom of projector.

	<p>CAUTION</p> <p>RISK OF ELECTRIC SHOCK. DO NOT REMOVE SCREWS EXCEPT SPECIFIED USER SERVICE SCREW.</p>	
<p>CAUTION: TO REDUCE THE RISK OF ELECTRIC SHOCK, DO NOT REMOVE COVER. NO USER-SERVICEABLE PARTS EXCEPT LAMP UNIT. REFER SERVICING TO QUALIFIED SERVICE PERSONNEL.</p>		



The lightning flash with arrowhead symbol, within an equilateral triangle, is intended to alert the user to the presence of uninsulated “dangerous voltage” within the product’s enclosure that may be of sufficient magnitude to constitute a risk or electric shock to persons.



The exclamation point within a triangle is intended to alert the user to the presence of important operating and maintenance (servicing) instructions in the literature accompanying the product.

WARNING: This is a Class A product. In a domestic environment this product may cause radio interference in which case the user may be required to take adequate measures.

WARNING: FCC Regulations state that any unauthorized changes or modifications to this equipment not expressly approved by the manufacturer could void the user’s authority to operate this equipment.

U.S.A. ONLY

PRODUCT DISPOSAL

This product utilizes tin-lead solder, and lamp containing a small amount of mercury. Disposal of these materials may be regulated due to environmental considerations. For disposal or recycling information, please contact your local authorities, the Electronics Industries Alliance: www.eiae.org, the lamp recycling organization www.lamprecycle.org, or Sharp at 1-800-BE-SHARP.

U.S.A. ONLY

This product contains a CR Coin Lithium Battery which contains Perchlorate Material – special handling may apply, California residents, See www.dtsc.ca.gov/hazardouswaste/perchlorate/

U.S.A. ONLY

INFORMATION

This equipment has been tested and found to comply with the limits for a Class B digital device, pursuant to Part 15 of the FCC Rules. These limits are designed to provide reasonable protection against harmful interference in a residential installation. This equipment generates, uses, and can radiate radio frequency energy and, if not installed and used in accordance with the operation manual, may cause harmful interference to radio communications. However, there is no guarantee that interference will not occur in a particular installation. If this equipment does cause harmful interference to radio or television reception, which can be determined by turning the equipment off and on, the user is encouraged to try to correct the interference by one or more of the following measures:

- Reorient or relocate the receiving antenna.
- Increase the separation between the equipment and the receiver.
- Connect the equipment into an outlet on a circuit different from that to which the receiver is connected.
- Consult the dealer or an experienced radio/TV technician for help.

U.S.A. ONLY

Declaration of conformity

SHARP PROJECTOR, MODEL XV-Z17000

This device complies with Part 15 of the FCC rules. Operation is subject to the following conditions: (1) This device may not cause harmful interference, and (2) this device must accept any interference received, including interference that may cause undesired operation.

Responsible Party:

SHARP ELECTRONICS CORPORATION
Sharp Plaza, Mahwah, New Jersey 07495-1163
TEL: 1-800-BE-SHARP (1-800-237-4277)

Caution Concerning Lamp Replacement

- This projector utilizes a pressurized mercury lamp. A loud sound may indicate lamp failure. Lamp failure can be attributed to numerous sources such as: excessive shock, improper cooling, surface scratches or deterioration of the lamp due to a lapse of usage time.
The period of time up to failure largely varies depending on the individual lamp and/or the condition and the frequency of use. It is important to note that failure can often result in the bulb cracking.
- When the lamp replacement indicator and on-screen display icon are illuminated, it is recommended that the lamp be replaced with a new one immediately, even if the lamp appears to be operating normally.
- Should the lamp break, there is also a possibility that glass particles may spread inside of the projector. In such a case, it is recommended you contact your nearest Sharp Authorized Projector Dealer or Service Center to assure safe operation.
- Should the lamp break, the glass particles may spread inside the lamp cage or gas contained in the lamp may be vented into the room from the exhaust vent. Because the gas in this lamp includes mercury, ventilate the room well if the lamp breaks and avoid all exposure to the released gas. In case of exposure to the gas, consult a doctor as soon as possible.

Caution

- Do not remove the lamp unit from the projector right after use. The lamp will be very hot and may cause burns or injury.
- Wait at least one hour after the power cord is disconnected to allow the surface of the lamp unit to fully cool before removing the lamp unit.
- Do not touch the glass surface of the lamp unit or the inside of the projector.
- Do not loosen other screws except for the lamp unit cover and lamp unit.
- Make sure to reset the lamp timer only when replacing the lamp. If you reset the lamp timer and continue to use the same lamp, this may cause the lamp to become damaged or explode.

■ Carefully change the lamp by following the instructions described on pages 62 to 64.

* If you wish, you may have the lamp replaced at your nearest Sharp Authorized Projector Dealer or Service Center.

* If the new lamp does not light after replacement, take your projector to the nearest Sharp Authorized Projector Dealer or Service Center for repair.

Authorized representative responsible for the European Union Community Market

SHARP ELECTRONICS (Europe) GmbH
Sonninstraße 3, D-20097 Hamburg

E.U. ONLY

How to Read this Operation Manual

- The specifications are slightly different, depending on the model. However, you can connect and operate all models in the same manner.
- In this operation manual, the illustration and the screen display are simplified for explanation, and may differ slightly from the actual display.

Using the Menu Screen

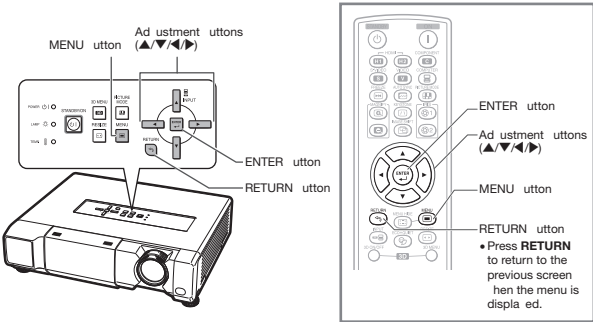

Buttons used in this operation

- ENTER button
- Adjustment buttons (▲/▼/◀/▶)
- MENU button
- RETURN button

• Press RETURN to return to the previous screen when the menu is displayed.

Buttons used in this operation

Button used in this step

Menu Selections (Adjustments)

• This operation can also be performed using the buttons on the projector.

- 1 Press **MENU**
 - The Picture menu screen for the selected input mode is displayed.
- 2 Press **▶** or **◀** to select the menu screen to adjust on the menu bar.

Example: "Picture" menu screen when COMPONENT is selected for input mode

Picture mode	SIG ADJ	SCR ADJ	PRJ ADJ	Menu bar
Contrast	01	01	01	[SEL/ADJ.] [ENTER]
Bright	01	01	01	[RETURN] [END]
Color	01	01	01	
Tint	01	01	01	
Sharp	01	01	01	
Red	01	01	01	
Blue	01	01	01	
CLR Temp	01	01	01	
IRIS (Manual)	01	01	01	◊ High Brightness
IRIS (Auto)	01	01	01	◊ On
Eco-Quiet	01	01	01	◊ Off
Advanced	01	01	01	
Reset	01	01	01	

On-screen display

Useful Features

GB-35

Info Indicates safeguards for using the projector.

Note Indicates additional information for setting up and operating the projector.

For Future Reference

Maintenance

➔ P. 59

Troubleshooting

➔ PP. 72 to 74

Index

➔ P. 78

Contents

Preparing

Introduction

How to Read this Operation Manual	3
Contents	4
IMPORTANT SAFEGUARDS	6
Accessories	9
Part Names and Functions	10
Using the Remote Control	13
Inserting the Batteries	13
Usable Range	13

Quick Start

Quick Start	14
-------------------	----

Using

Basic Operation

Turning the Projector On/Off	23
Connecting the Power Cord	23
Turning the Projector On	23
Turning the Power Off (Putting the Projector into Standby Mode)	23
Image Projection	24
Adjusting the Projected Image	24
Keystone Correction	25
Switching the Input Mode	27
Adjusting the Vertical and Horizontal Position of the Image	27
Displaying the Black Screen Temporarily	28
Freezing a Moving Image	28
Auto Sync (Auto Sync Adjustment)	28
Selecting the Picture Mode	28
Displaying an Enlarged Portion of an Image	29
Switching the Iris Setting	29
Hiding the Menu Temporarily (Menu Hide)	29
Switching the Eco+Quiet Mode	29
Resize Mode	30

Useful Features

Menu Bar Items	32
Using the Menu Screen	35
Menu Selections (Adjustments)	35
Picture Adjustment ("Picture" Menu)	37
Selecting the Picture Mode	37
Adjusting the Image	37
Switching the Iris Setting	38
Eco+Quiet	38
Using the Advanced	38
Correcting Gradation of Video (Gamma Correction)	38
Adjusting the Colors	38
Adjusting the Bright Boost	40
Selecting the Film Mode	40
Setting Detail Enhancement	40
Reducing Image Noise (DNR)	40
Mosquito Noise Reduction (MNR)	40
Resetting All Adjustment Items	40
Computer Image Adjustment ("SIG-ADJ" Menu)	41
Adjusting the Computer Image	41

Setup

Setting Up the Projector	16
Setting Up the Projector	16
Standard Setup (Front Projection)	16
Projection (PRJ) Mode	17
Ceiling-mount Setup	17
Screen Size and Projection Distance	18

Connections

Samples of Cables for Connection	19
Connecting to Video Equipment	20
Connecting to a Computer	21
Controlling the Projector by a Computer	22

Setting the Resolution	41
Auto Sync (Auto Sync Adjustment)	41
Signal Type Setting	41
Setting the Video System	42
Setting the Video Setup	42
Adjusting the Dynamic Range	42
Signal Info	42

Adjusting the Projected Image ("SCR-ADJ" Menu)

Setting the Resize Mode	43
Adjusting the Image Position	43
Adjusting the Overscan	43
Auto V-Keystone Correction	44
Keystone Mode Correction	44
Setting On-screen Display	45
Setting the Brightness of the Menu Screen	45
Selecting the Background Image	45
Selecting the Menu Screen Position	45
Reversing/Inverting Projected Images	45
Selecting the On-screen Display Language	45

Adjusting the Projector Function ("PRJ-ADJ" Menu)

Setting Auto Power Off Mode	46
Setting the Power Save Mode (Economy Mode)	46
Setting One Touch Play, System Standby and Input Name	46
Setting the Demo Mode	47
Selecting the Transmission Speed (RS-232C)	47
Fan Mode Setting	47
Returning to the Default Settings	47
Lamp Timer (Life)	47

Enjoying 3D Image Viewing

Precautions on using 3D Glasses	48
Precautions on viewing 3D images	48
Supplied Accessories for 3D Glasses	50
Part Names	50
Before Using the 3D Glasses	51
Replacing the Button Cell Battery	51
Attaching the Nose Pad	52
Attaching the 3D Glasses Band	52
Using the 3D Glasses	52
Usage Range of the 3D Glasses	52
Viewing 3D Images	53
3D Settings ("3D MENU")	55
Setting the 3D Format Menu	56
Specifications – 3D Glasses	58

Reference

Appendix

Maintenance	59
Maintenance Indicators	60
Regarding the Lamp	62
Lamp	62
Caution Concerning the Lamp	62
Replacing the Lamp	62
Removing and Installing the Lamp Unit	63
Resetting the Lamp Timer	64

Connecting Pin Assignments	65
RS-232C Specifications and Commands	66
Compatibility Chart	70
Troubleshooting	72
For SHARP Assistance	75
Specifications	76
Dimensions	77
Index	78

- DLP® and the DLP logo are registered trademarks of Texas Instruments.
- Microsoft® and Windows® are registered trademarks of Microsoft Corporation in the United States and/or other countries.
- PC/AT is a registered trademark of International Business Machines Corporation in the United States.
- Macintosh® is a registered trademark of Apple Computer, Inc. in the United States and/or other countries.
- HDMI, the HDMI logo and High-Definition Multimedia Interface are trademarks or registered trademarks of HDMI Licensing LLC.
- All other company or product names are trademarks or registered trademarks of their respective companies.
- Some IC chips in this product include confidential and/or trade secret property belonging to Texas Instruments. Therefore you may not copy, modify, adapt, translate, distribute, reverse engineer, reverse assemble or discompile the contents thereof.

IMPORTANT SAFEGUARDS

CAUTION: Please read all of these instructions before you operate this product and save these instructions for later use.

Electrical energy can perform many useful functions. This product has been engineered and manufactured to assure your personal safety. BUT IMPROPER USE CAN RESULT IN POTENTIAL ELECTRICAL SHOCK OR FIRE HAZARDS. In order not to defeat the safeguards incorporated in this product, observe the following basic rules for its installation, use and servicing.

1. Read Instructions

All the safety and operating instructions should be read before the product is operated.

2. Retain Instructions

The safety and operating instructions should be retained for future reference.

3. Heed Warnings

All warnings on the product and in the operating instructions should be adhered to.

4. Follow Instructions

All operating and use instructions should be followed.

5. Cleaning

Unplug this product from the wall outlet before cleaning. Do not use liquid cleaners or aerosol cleaners. Use a damp cloth for cleaning.

6. Attachments

Do not use attachments not recommended by the product manufacturer as they may cause hazards.

7. Water and Moisture

Do not use this product near water—for example, near a bath tub, wash bowl, kitchen sink, or laundry tub; in a wet basement; or near a swimming pool; and the like.

8. Accessories

Do not place this product on an unstable cart, stand, tripod, bracket, or table. The product may fall, causing serious injury to a child or adult, and serious damage to the product. Use only with a cart, stand, tripod, bracket, or table recommended by the manufacturer, or sold with the product. Any mounting of the product should follow the manufacturer's instructions, and should use a mounting accessory recommended by the manufacturer.

9. Transportation

A product and cart combination should be moved with care. Quick stops, excessive force, and uneven surfaces may cause the product and cart combination to overturn.



10. Ventilation

Slots and openings in the cabinet are provided for ventilation to ensure reliable operation of the product and to protect it from overheating, and these openings must not be blocked or covered. The openings should never be blocked by placing the product on a bed, sofa, rug, or other similar surface. This product should not be placed in a built-in installation such as a bookcase or rack unless proper ventilation is provided or the manufacturer's instructions have been adhered to.

11. Power Sources

This product should be operated only from the type of power source indicated on the marking label. If you are not sure of the type of power supply to your home, consult your product dealer or local power company. For products intended to operate from battery power, or other sources, refer to the operating instructions.

12. Grounding or Polarization

This product is provided with one of the following types of plugs. If the plug should fail to fit into the power outlet, please contact your electrician.

Do not defeat the safety purpose of the plug.

- Two-wire type (mains) plug.
- Three-wire grounding type (mains) plug with a grounding terminal.
This plug will only fit into a grounding type power outlet.

13. Power-Cord Protection

Power-supply cords should be routed so that they are not likely to be walked on or pinched by items placed upon or against them, paying particular attention to cords at plugs, convenience receptacles, and the point where they exit from the product.

14. Lightning

For added protection for this product during a lightning storm, or when it is left unattended and unused for long periods of time, unplug it from the wall outlet and disconnect the cable system. This will prevent damage to the product due to lightning and power-line surges.

15. Overloading

Do not overload wall outlets, extension cords, or integral convenience receptacles as this can result in a risk of fire or electric shock.

16. Object and Liquid Entry

Never push objects of any kind into this product through openings as they may touch dangerous voltage points or short-out parts that could result in a fire or electric shock. Never spill liquid of any kind on the product.

17. Servicing

Do not attempt to service this product yourself as opening or removing covers may expose you to dangerous voltage or other hazards. Refer all servicing to qualified service personnel.

18. Damage Requiring Service

Unplug this product from the wall outlet and refer servicing to qualified service personnel under the following conditions:

- When the power-supply cord or plug is damaged.
- If liquid has been spilled, or objects have fallen into the product.
- If the product has been exposed to rain or water.
- If the product does not operate normally by following the operating instructions. Adjust only those controls that are covered by the operating instructions, as an improper adjustment of other controls may result in damage and will often require extensive work by a qualified technician to restore the product to normal operation.
- If the product has been dropped or damaged in any way.
- When the product exhibits a distinct change in performance, this indicates a need for service.

19. Replacement Parts

When replacement parts are required, be sure the service technician has used replacement parts specified by the manufacturer or have the same characteristics as the original part. Unauthorized substitutions may result in fire, electric shock, or other hazards.

20. Safety Check

Upon completion of any service or repairs to this product, ask the service technician to perform safety checks to determine that the product is in proper operating condition.

21. Wall or Ceiling Mounting

This product should be mounted to a wall or ceiling only as recommended by the manufacturer.

22. Heat

This product should be situated away from heat sources such as radiators, heat registers, stoves, or other products (including amplifiers) that produce heat.

Observe the following safeguards when setting up your projector.

Caution concerning the lamp unit

- Potential hazard of glass particles if lamp ruptures. In case of lamp rupture, contact your nearest Sharp Authorized Projector Dealer or Service Center for replacement. See “Regarding the Lamp” on page 62.

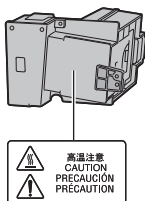

Caution concerning the setup of the projector

- For minimal servicing and to maintain high image quality, SHARP recommends that this projector be installed in an area free from humidity, dust and cigarette smoke. When the projector is subjected to these environments, the vents and lens must be cleaned more often. As long as the projector is regularly cleaned, use in these environments will not reduce the overall operation life of the unit. Internal cleaning should only be performed by a Sharp Authorized Projector Dealer or Service Center.

Do not set up the projector in places exposed to direct sunlight or bright light.

- Position the screen so that it is not in direct sunlight or room light. Light falling directly on the screen washes out the colors, making viewing difficult. Close the curtains and dim the lights when setting up the screen in a sunny or bright room.

Caution regarding placing of the projector

- Place the projector on a level site within the adjustment range (9 degrees) of the adjustment foot.

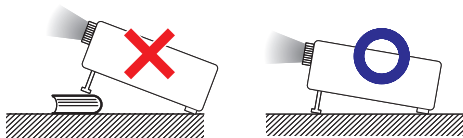

- After the projector is purchased, a faint smell from the vent may appear when the power is first turned on. This is normal and is not a malfunction. It will disappear after the projector is used for a while.

When using the projector in high-altitude areas such as mountains (at altitudes of approximately 4,900 feet (1,500 meters) or more)

- When you use the projector in high-altitude areas with thin air, set “Fan Mode” to “High”. Neglecting this can affect the longevity of the optical system.
- Use the projector at altitudes of 7,500 feet (2,300 meters) or less.

Warning about placing the projector in a high position

- When placing the projector in a high position, make certain it is carefully secure to avoid personal injury caused by the projector falling down.

Do not subject the projector to hard impact and/or vibration.

- Protect the lens so as not to hit or damage the surface of the lens.

Rest your eyes occasionally.

- Continuously watching the screen for long hours will cause eye strain. Take regular breaks to rest your eyes.

Avoid locations with extremes of temperature.

- The operating temperature of the projector is from 41°F to 95°F (+5°C to +35°C).
- The storage temperature of the projector is from -4°F to 140°F (-20°C to +60°C).

Do not block the exhaust and intake vents.

- Allow at least 11¹³/₁₆ inches (30 cm) of space between the exhaust vent and the nearest wall or obstruction.
- Ensure that the intake vent and the exhaust vent are not obstructed.
- If the cooling fan becomes obstructed, a protection circuit will automatically put the projector into standby mode to prevent overheat damage. This does not indicate a malfunction. (See page 60.) Remove the projector power cord from the wall outlet and wait at least 10 minutes. Place the projector where the intake and exhaust vents are not blocked, plug the power cord back in and turn on the projector. This will return the projector to the normal operating condition.

Caution regarding usage of the projector

- If you are not to use the projector for a long time or before moving the projector, make certain you unplug the power cord from the wall outlet, and disconnect any other cables connected to it.
- Do not carry the projector by holding the lens.
- When storing the projector, ensure that you close the lens shutter.
- Do not expose the projector to direct sunlight or place next to heat sources. Doing so may affect the cabinet color or cause deformation of the plastic cover.

Other connected equipment

- When connecting a computer or other audio-visual equipment to the projector, make the connections AFTER unplugging the power cord of the projector from the AC outlet and turning off the equipment to be connected.
- Please read the operation manuals of the projector and the equipment to be connected for instructions on how to make the connections.

Using the projector in other countries

- The power supply voltage and the shape of the plug may vary depending on the region or country you are using the projector in. When using the projector overseas, make sure you use an appropriate power cord for the country you are in.

Temperature monitor function



- If the temperature inside the projector increases, due to blockage of the air vents, or the setting location, the temperature warning indicator will blink. And if the temperature keeps on rising, “ TEMP.” will illuminate in the lower left corner of the picture with the temperature warning indicator blinking. If this state continues, the lamp will turn off, the cooling fan will run and then the projector will enter standby mode. Refer to “Maintenance Indicators” on pages 60 and 61 for details.

Info

- The cooling fan regulates the internal temperature, and its performance is automatically controlled. The sound of the fan may change during projector operation due to changes in the fan speed. This does not indicate malfunction.

Observe the following safeguards when using the 3D Glasses.

Prevention of accidental ingestion

- Keep the batteries and band accessory out of the reach of small children. Small children can accidentally swallow these parts.
 - If a child accidentally swallows any of these parts, seek immediate medical attention.

Do not disassemble

- Do not disassemble or modify the 3D Glasses.

Caution for lithium battery

- Batteries must not be exposed to excessive heat such as direct sunlight or fire.
- Replace only with the same or equivalent type of battery. The battery may explode if improperly replaced.
- Take care not to reverse the battery poles (+ and –) when loading the battery. Follow the correct procedure when loading the battery. (See page 51.) Loading the battery incorrectly may damage the battery or cause it to leak battery fluid, which could result in a fire, injury or damage.

Handling the 3D Glasses

- Do not drop, exert pressure on, or step on the 3D Glasses. Doing so may damage the glass section, which may result in injury.
- Be careful not to trap your finger in the hinge section of the 3D Glasses. Doing so may result in injury.
 - Pay special attention when children are using this product.

Using the 3D Glasses

- Parents/guardians should monitor children’s viewing habits to avoid their prolonged use without rest periods.
- Use only the 3D Glasses recommended for this product.
- Use the 3D Glasses only for the specified purpose.
- Do not move around while wearing the 3D Glasses. The surrounding area appears dark, which may result in falling or other accidents that may cause injury.

Caring for the 3D Glasses

- Use only the cloth provided with the 3D Glasses to clean the lenses. Remove dust and soil from the cloth. Any dust or other soiling on the cloth may result in scratches on the product. Do not use solvents such as benzene or thinners as doing so may cause the coating to peel off.
- When cleaning the 3D Glasses, take care not to allow water or other fluids to come into contact with the glasses.
- Always store the 3D Glasses in the case provided when not in use.
- When storing the 3D Glasses, avoid very humid or hot locations.

Viewing 3D images

- If you experience dizziness, nausea, or other discomfort while viewing 3D images, discontinue use and rest your eyes.
- Do not use the 3D Glasses if they are cracked or broken.

Supplied accessories



Remote control
<RRMCGA929WJSA>



Two AA size batteries
<UBATUA020WJZZ>



Two pairs of 3D Glasses¹
<KOPTLA002WJN1>

Power cord²

(1)

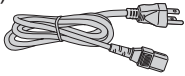

For U.S. and
Canada, etc.
(6' (1.8 m))

<QACCDAA007WJPZ>

(2)

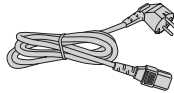

For Europe,
except U.K.
(6' (1.8 m))

<QACCVA011WJPZ>

(3)

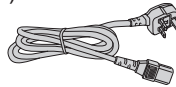

For U.K. and
Singapore
(6' (1.8 m))

<QACCBAA036WJPZ>

(4)

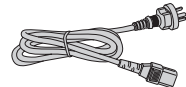

For Australia,
New Zealand and Oceania
(6' (1.8 m))

<QACCLA018WJPZ>

*1 See pages **50** to **52** for details of the 3D Glasses and their accessories.

*2 Which power cords are supplied along with your projector depends on the region. Use the power cord that corresponds to the wall outlet in your country.

- Operation manual <TINS-E929WJZZ>

Note

- Codes in “< >” are Replacement parts codes.

Optional accessories

■ Lamp unit	AN-K15LP
■ Ceiling-mount adaptor	AN-60KT
■ Ceiling-mount bracket	AN-XRCM30 (for U.S.A. only)
■ Ceiling-mount unit	AN-TK201 <for AN-60KT>
	AN-TK202 <for AN-60KT>
■ Ceiling-mount extension tube	AN-EP101B <for AN-XRCM30>
	(for U.S.A. only)
■ 3 RCA to mini D-sub 15 pin cable (10' (3.0 m))	AN-C3CP2
■ 3D Glasses	AN-3DG10-S
	AN-3DG10-R
	AN-3DG10-A

Note

- Some of the optional accessories may not be available depending on the region. Please check with your nearest Sharp Authorized Projector Dealer or Service Center.

Part Names and Functions

Numbers in **■** refer to the main pages in this operation manual where the topic is explained.

Projector

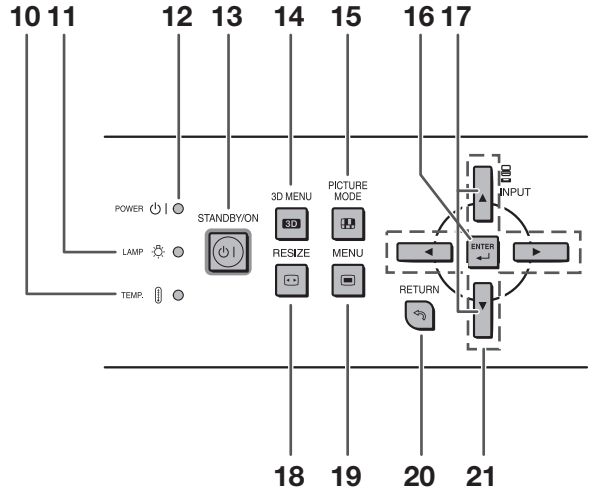
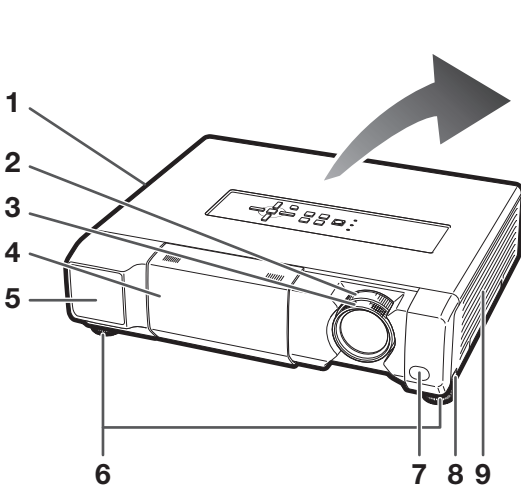

Front View

- 1 Exhaust vent **59**
- 2 Zoom ring **15, 24**
For enlarging/reducing the picture.
- 3 Focus ring **15, 24**
For adjusting the focus.
- 4 Lens shutter **23, 28, 63**
- 5 IR (infrared) emitter **52**
Emits an infrared signal when 3D images are projected.
- 6 Adjustment foot **15, 24**
- 7 Remote control sensor **13**
- 8 HEIGHT ADJUST lever **24**
- 9 Intake vent **59**

Top View

- 10 Temperature warning indicator **60**
- 11 Lamp indicator **23, 60**
- 12 Power indicator **23, 60**
- 13 STANDBY/ON button **14, 23**
For turning the power on and putting the projector into standby mode.
- 14 3D MENU button **53**
For displaying the 3D MENU screen.
- 15 PICTURE MODE button **28**
For selecting the appropriate picture.
- 16 ENTER button **35**
For setting items selected or adjusted on the menu.
- 17 INPUT buttons (▲/▼) **27**
For switching input mode.
- 18 RESIZE button **30**
For switching the picture size (NORMAL, 16:9, etc.).
- 19 MENU button **35**
For displaying adjustment and setting screens.
- 20 RETURN button **35**
For returning to the previous menu screen during menu operations.
- 21 Adjustment buttons (▲/▼/◀/▶) **35**
For selecting menu items.

Projector (Rear View)

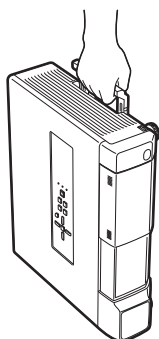
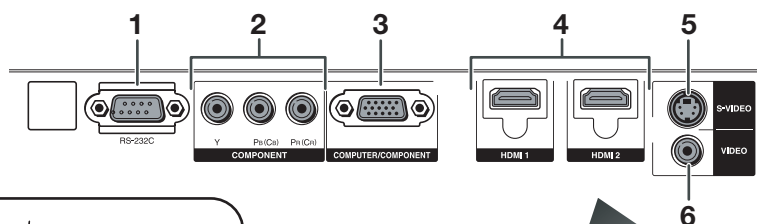

Using the Carrying Handle

When transporting the projector, carry it by the carrying handle on the side.

- Always close the lens shutter to prevent damage to the lens when transporting the projector.
- Do not lift or carry the projector by the lens as this may damage the lens.

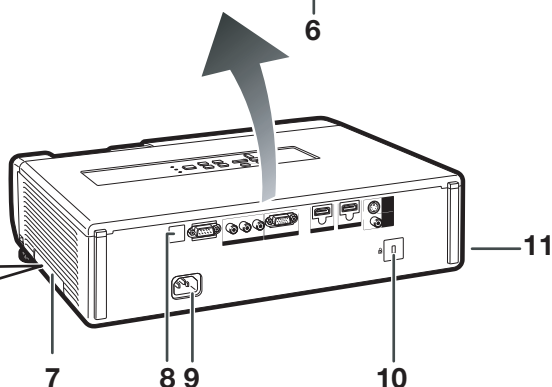

Terminals

- | | |
|---|--|
| <p>1 RS-232C terminal 22
Terminal for controlling the projector using a computer.</p> <p>2 COMPONENT terminals 19
Terminal for connecting video equipment with component output terminal.</p> <p>3 COMPUTER/COMPONENT input terminal 19, 21
Terminal for computer RGB and YPbPr signals.</p> <p>4 HDMI1, 2 terminals 19, 20
Terminal for connecting video equipment with HDMI output terminal.</p> <p>5 S-VIDEO input terminal 19, 20
Terminal for connecting video equipment with an S-video terminal.</p> | <p>6 VIDEO input terminal 19
Terminal for connecting video equipment.</p> <p>7 Carrying handle
For carrying the projector.</p> <p>8 Remote control sensor 13</p> <p>9 AC socket 23
Connect the supplied power cord.</p> <p>10 Kensington Security Standard connector</p> <p>11 Security bar</p> |
|---|--|

Using the Kensington Lock

- This projector has a Kensington Security Standard connector for use with a Kensington MicroSaver Security System. Refer to the information that came with the system for instructions on how to use it to secure the projector.

Part Names and Functions (Continued)

Numbers in **■** refer to the main pages in this operation manual where the topic is explained.

Remote Control

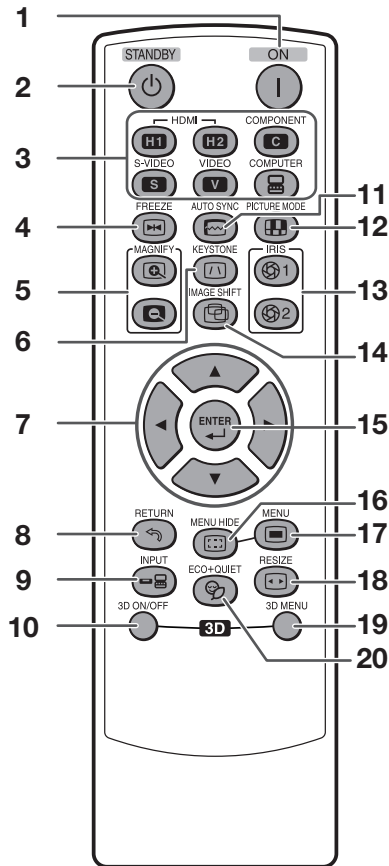

- 1** ON button **14, 23**
For turning the power on.
- 2** STANDBY button **15, 23**
For putting the projector into the standby mode.
- 3** HDMI1, 2, COMPONENT, S-VIDEO, VIDEO, COMPUTER buttons **15, 27**
For switching to the respective input modes.
- 4** FREEZE button **28**
For freezing images.
- 5** MAGNIFY buttons **29**
For enlarging/reducing part of the image.
- 6** KEYSTONE button **25**
For entering the Keystone mode.
- 7** Adjustment buttons (▲/▼/◀/▶) **35**
For selecting and adjusting menu items.
- 8** RETURN button **35**
For returning to the previous menu screen during menu operations.
- 9** INPUT button **27**
For switching input mode.
- 10** 3D ON/OFF button **53, 54**
For switching between 2D and 3D modes.
- 11** AUTO SYNC button **28**
For automatically adjusting images when connected to a computer.
- 12** PICTURE MODE button **28**
For selecting the appropriate picture.
- 13** IRIS 1, 2 buttons **29**
For switching “High Brightness” and “High Contrast”.
- 14** IMAGE SHIFT button **27**
For shifting images horizontally and vertically.
- 15** ENTER button **35**
For setting items selected or adjusted on the menu.
- 16** MENU HIDE button **29**
For temporarily hiding menu screen.
- 17** MENU button **35**
For displaying adjustment and setting screens.
- 18** RESIZE button **30**
For switching the picture size (NORMAL, 16:9, etc.).
- 19** 3D MENU button **53**
For displaying the 3D MENU screen.
- 20** ECO+QUIET button **29**
For lowering the noise of the cooling fan and extending the lamp life.

Using the Remote Control

Inserting the Batteries

1 Pull down the tab on the cover and remove the cover towards the direction of the arrow.

2 Insert the supplied batteries and put back the cover.

- Make sure the polarities correctly match the \oplus and \ominus marks inside the battery compartment.
- When putting back the cover, be sure that the cover clicks in place and settles.

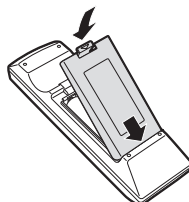
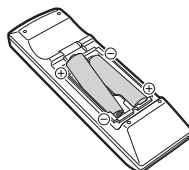
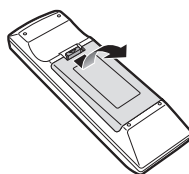

Usable Range

The remote control can be used to control the projector within the ranges shown in the illustration.

Note

- Remote control sensor is located on both the front and rear of the projector.
- The signal from the remote control can be reflected off a screen for easy operation. However, the effective distance of the signal may differ depending on the screen material.

When using the remote control:

- Be sure not to drop, expose to moisture or high temperature.
- The remote control may malfunction under a fluorescent lamp. In this case, move the projector away from the fluorescent lamp.

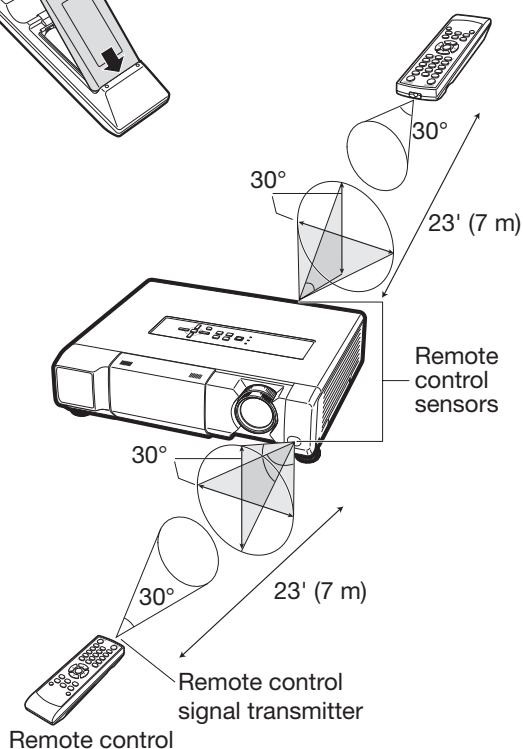

Incorrect use of the batteries may cause them to leak or explode. Please follow the precautions below

Caution

- Danger of explosion if battery is incorrectly replaced. Replace only with alkaline or manganese batteries.
- Insert the batteries making sure the polarities correctly match the \oplus and \ominus marks inside the battery compartment.
- Batteries of different types have different properties, therefore do not mix batteries of different types.
- Do not mix new and old batteries. This may shorten the life of new batteries or may cause old batteries to leak.
- Remove the batteries from the remote control once they have run out, as leaving them in can cause them to leak. Battery fluid from leaked batteries is harmful to skin, therefore ensure you wipe them first and then remove them using a cloth.
- The batteries included with this projector may run down in a short period, depending on how they are kept. Be sure to replace them as soon as possible with new batteries.
- Remove the batteries from the remote control if you will not be using the remote control for a long time.
- Comply with the rules (ordinance) of each local government when disposing of worn-out batteries.

Quick Start

This section provides an example showing how to connect the projector to video equipment that has an HDMI output terminal with a brief explanation of the steps from connection through to image projection. For details, see the pages suggested in each step.

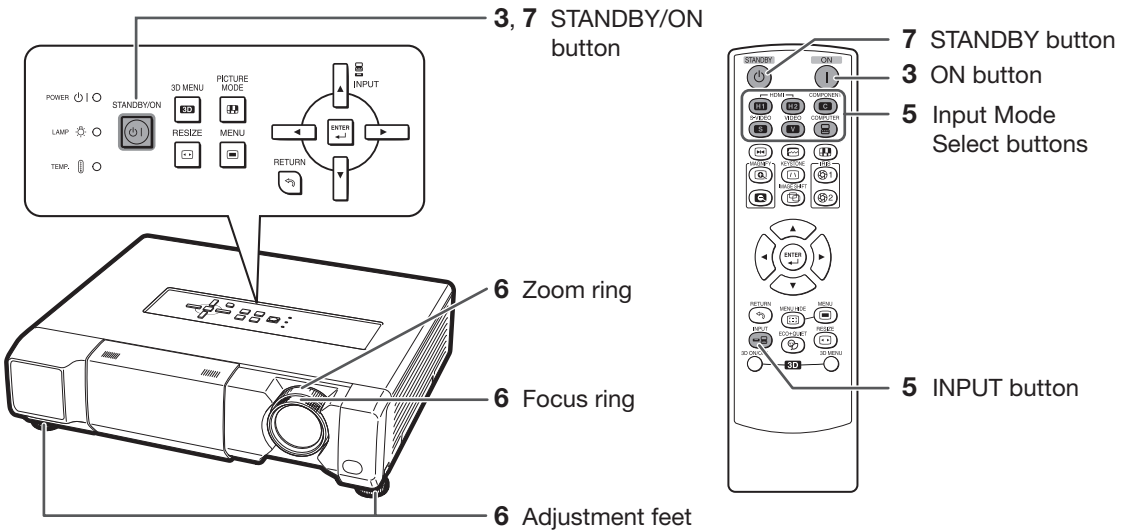

1. Place the projector facing a screen

→ Page 16

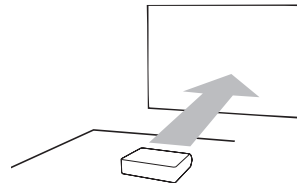

2. Connect the projector to the video equipment and plug the power cord into the AC socket of the projector

→ Pages 19-23

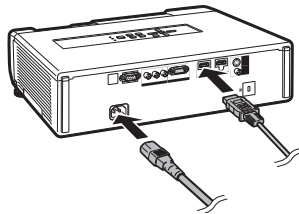

3. Open the lens shutter fully and then turn the projector on

→ Page 23

On the projector

② STANDBY/ON button

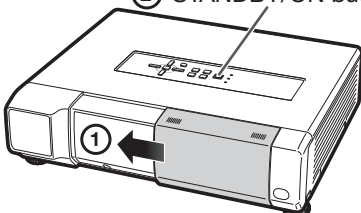

Press **STANDBY/ON** on the projector or **ON** on the remote control pointing the remote control towards the projector.

On the remote control

② ON button



4. Turn the video equipment on and start playback

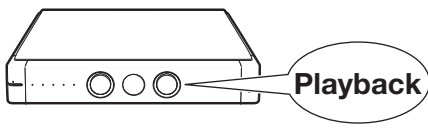

5. Select the input mode → Page 27

Press **HDMI1** on the remote control to select "HDMI1" for the Input mode.

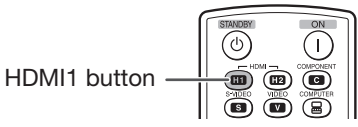

- Press **HDMI1**, **HDMI2**, **COMPONENT**, **S-VIDEO**, **VIDEO** and **COMPUTER** on the remote control to switch the Input mode.
- Press **▲** or **▼** to select your desired input mode when you press **INPUT** on the remote control or on the projector.

6. Adjust the projector angle, focus and zoom → Page 24

1. The focus is adjusted by rotating the focus ring.

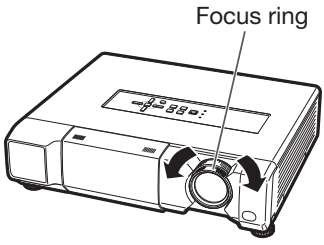

2. Zooming is adjusted by rotating the zoom ring.

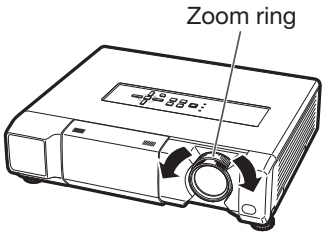

3. The projector angle is adjusted by using the adjustment feet.

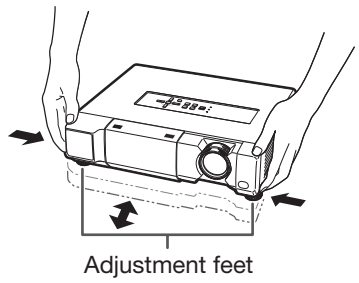

- When the image is distorted trapezoidally, the keystone correction is needed. (See page 25.)

7. Turn the power off → Page 23

Press **STANDBY/ON** on the projector or **STANDBY** on the remote control, then press that button again while the confirmation message is displayed, to put the projector into standby mode.

On the projector

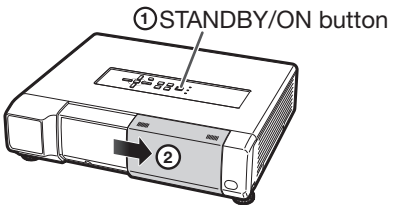

On the remote control

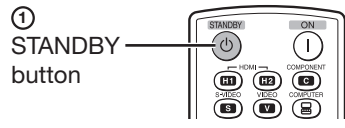

On-screen display



Setting Up the Projector

Setting Up the Projector

For optimal image quality, position the projector perpendicular to the screen with the projector's feet flat and level.

Note

- The projector lens should be centered in the middle of the screen. If the horizontal line passing through the lens center is not perpendicular to the screen, the image will be distorted, making viewing difficult.
- For optimal image, position the screen so that it is not in direct sunlight or room light. Light falling directly on the screen washes out the colors, making viewing difficult. Close the curtains and dim the lights when setting up the screen in a sunny or bright room.

Standard Setup (Front Projection)

- Place the projector at the required distance from the screen according to the desired picture size.

Example of standard setup

Side View

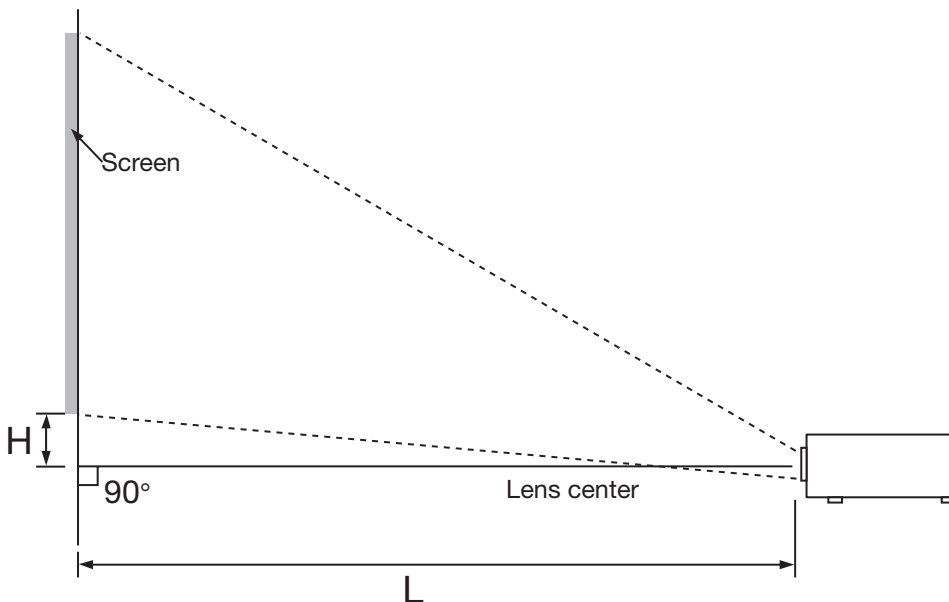

Note

- Refer to page 18 for additional information concerning "Screen Size and Projection Distance".

Projection (PRJ) Mode

The projector can use any of the 4 projection modes, shown in the diagram below. Select the mode most appropriate for the projection setting in use. (You can set the PRJ Mode in “SCR-ADJ” menu. See page 45.)

■ Table mounted, front projection

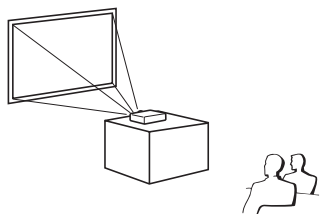

Menu item → “Front”

■ Ceiling mounted, front projection

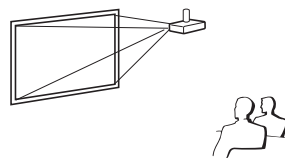

Menu item → “Ceiling + Front”

■ Table mounted, rear projection (with a translucent screen)

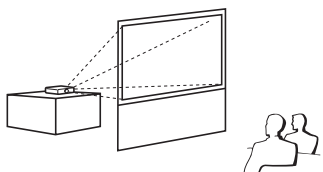

Menu item → “Rear”

■ Ceiling mounted, rear projection (with a translucent screen)

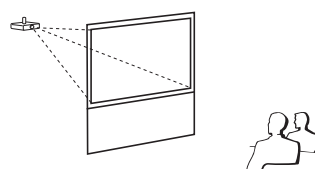

Menu item → “Ceiling + Rear”

Ceiling-mount Setup

■ It is recommended that you use the optional Sharp ceiling-mount adaptor and unit for this installation. Before mounting the projector, contact your nearest Sharp Authorized Projector Dealer or Service Center to obtain the recommended ceiling-mount adaptor and unit (sold separately).

Indication of the Projection Image Size and Projection Distance

For details, refer to “Screen Size and Projection Distance” on page 18.

Example : When using a wide screen (16:9)

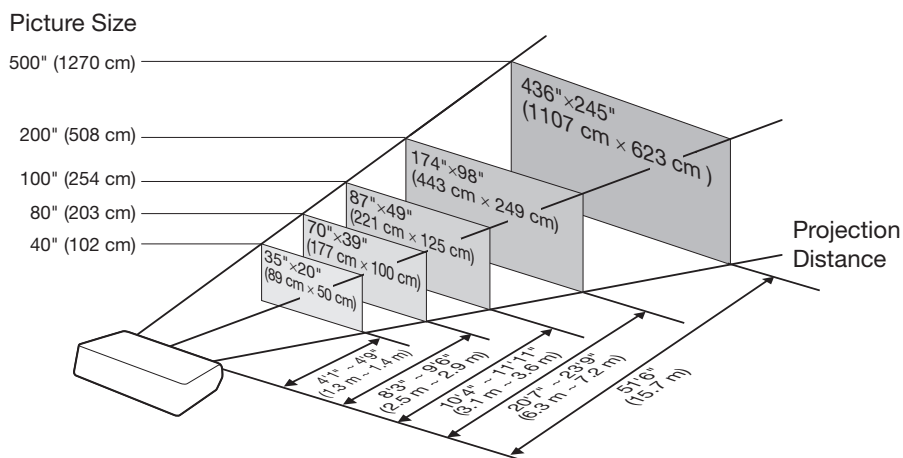

Setting Up the Projector (Continued)

Screen Size and Projection Distance

When using a wide screen (16:9): In case of displaying the 16:9 picture on the whole of the 16:9 screen.

Diag. (x)	Picture (Screen) size		Projection distance [L]		Distance from the lens center to the bottom of the image [H]
	Width	Height	Minimum [L1]	Maximum [L2]	
500" (1270 cm)	436" (1107 cm)	245" (623 cm)	51'6" (15.7 m)	—	39 3/8" (100 cm)
400" (1016 cm)	349" (886 cm)	196" (498 cm)	41'2" (12.6 m)	47'6" (14.5 m)	31 1/2" (80 cm)
300" (762 cm)	261" (664 cm)	147" (374 cm)	30'11" (9.4 m)	35'8" (10.9 m)	23 5/8" (60 cm)
250" (635 cm)	218" (553 cm)	123" (311 cm)	25'9" (7.9 m)	29'8" (9.1 m)	19 11/16" (50 cm)
200" (508 cm)	174" (443 cm)	98" (249 cm)	20'7" (6.3 m)	23'9" (7.2 m)	15 3/4" (40 cm)
150" (381 cm)	131" (332 cm)	74" (187 cm)	15'5" (4.7 m)	17'10" (5.4 m)	11 13/16" (30 cm)
120" (305 cm)	105" (266 cm)	59" (149 cm)	12'4" (3.8 m)	14'3" (4.3 m)	9 29/64" (24 cm)
100" (254 cm)	87" (221 cm)	49" (125 cm)	10'4" (3.1 m)	11'11" (3.6 m)	7 7/8" (20 cm)
80" (203 cm)	70" (177 cm)	39" (100 cm)	8'3" (2.5 m)	9'6" (2.9 m)	6 19/64" (16 cm)
60" (152 cm)	52" (133 cm)	29" (75 cm)	6'2" (1.9 m)	7'2" (2.2 m)	4 23/32" (12 cm)
40" (102 cm)	35" (89 cm)	20" (50 cm)	4'1" (1.3 m)	4'9" (1.4 m)	3 5/32" (8 cm)

x : Picture (Screen) diagonal size: 40" – 500"

L : Projection distance (ft/m)

L1: Minimum projection distance (ft/m)

L2: Maximum projection distance (ft/m)

H : Distance from the lens center to the bottom of the image (in/cm)

The formula for picture size and projection distance

[Feet/inches]

L1(ft) = 0.0314 x / 0.3048

L2(ft) = 0.0362 x / 0.3048

H (in) = 0.2 x / 2.54

[m/cm]

L1(m) = 0.0314 x

L2(m) = 0.0362 x

H (cm) = 0.2 x

When using a normal screen (4:3): In case of displaying the 4:3 picture on the whole of the 4:3 screen.

Diag. (x)	Picture (Screen) size		Projection distance [L]		Distance from the lens center to the bottom of the image [H]
	Width	Height	Minimum [L1]	Maximum [L2]	
400" (1016 cm)	320" (813 cm)	240" (610 cm)	50'5" (15.4 m)	—	38 35/64" (98 cm)
300" (762 cm)	240" (610 cm)	180" (457 cm)	37'10" (11.5 m)	43'7" (13.3 m)	28 29/32" (73 cm)
250" (635 cm)	200" (508 cm)	150" (381 cm)	31'6" (9.6 m)	36'4" (11.1 m)	24 3/32" (61 cm)
200" (508 cm)	160" (406 cm)	120" (305 cm)	25'3" (7.7 m)	29'1" (8.9 m)	19 17/64" (49 cm)
150" (381 cm)	120" (305 cm)	90" (229 cm)	18'11" (5.8 m)	21'10" (6.6 m)	14 29/64" (37 cm)
120" (305 cm)	96" (244 cm)	72" (183 cm)	15'2" (4.6 m)	17'5" (5.3 m)	11 9/16" (29 cm)
100" (254 cm)	80" (203 cm)	60" (152 cm)	12'7" (3.8 m)	14'6" (4.4 m)	9 41/64" (24 cm)
80" (203 cm)	64" (163 cm)	48" (122 cm)	10'1" (3.1 m)	11'8" (3.5 m)	7 45/64" (20 cm)
70" (178 cm)	56" (142 cm)	42" (107 cm)	8'10" (2.7 m)	10'2" (3.1 m)	6 3/4" (17 cm)
60" (152 cm)	48" (122 cm)	36" (91 cm)	7'7" (2.3 m)	8'9" (2.7 m)	5 25/32" (15 cm)
40" (102 cm)	32" (81 cm)	24" (61 cm)	5'1" (1.5 m)	5'10" (1.8 m)	3 55/64" (10 cm)

x : Picture (Screen) diagonal size: 40" – 400"

L : Projection distance (ft/m)

L1: Minimum projection distance (ft/m)

L2: Maximum projection distance (ft/m)

H : Distance from the lens center to the bottom of the image (in/cm)

The formula for picture size and projection distance

[Feet/inches]

L1(ft) = 0.03843 x / 0.3048

L2(ft) = 0.0443 x / 0.3048

H (in) = 0.24477 x / 2.54

[m/cm]

L1(m) = 0.03843 x

L2(m) = 0.0443 x

H (cm) = 0.24477 x

When using a normal screen (4:3): In case of setting the 16:9 picture to the full horizontal width of the 4:3 screen.

Diag. (x)	Screen size		Projection distance [L]		Distance from the lens center to the bottom of the image [H]
	Width	Height	Minimum [L1]	Maximum [L2]	
500" (1270 cm)	400" (1016 cm)	300" (762 cm)	47'3" (14.4 m)	—	36 9/64" (92 cm)
400" (1016 cm)	320" (813 cm)	240" (610 cm)	37'10" (11.5 m)	43'7" (13.3 m)	28 29/32" (73 cm)
300" (762 cm)	240" (610 cm)	180" (457 cm)	28'4" (8.6 m)	32'8" (10.0 m)	21 11/16" (55 cm)
250" (635 cm)	200" (508 cm)	150" (381 cm)	23'8" (7.2 m)	27'3" (8.3 m)	18 1/16" (46 cm)
200" (508 cm)	160" (406 cm)	120" (305 cm)	18'11" (5.8 m)	21'10" (6.6 m)	14 29/64" (37 cm)
150" (381 cm)	120" (305 cm)	90" (229 cm)	14'2" (4.3 m)	16'4" (5.0 m)	10 27/32" (28 cm)
120" (305 cm)	96" (244 cm)	72" (183 cm)	11'4" (3.5 m)	13'1" (4.0 m)	8 43/64" (22 cm)
100" (254 cm)	80" (203 cm)	60" (152 cm)	9'5" (2.9 m)	10'11" (3.3 m)	7 15/64" (18 cm)
80" (203 cm)	64" (163 cm)	48" (122 cm)	7'7" (2.3 m)	8'9" (2.7 m)	5 25/32" (15 cm)
70" (178 cm)	56" (142 cm)	42" (107 cm)	6'7" (2.0 m)	7'8" (2.3 m)	5 1/16" (13 cm)
60" (152 cm)	48" (122 cm)	36" (91 cm)	5'8" (1.7 m)	6'6" (2.0 m)	4 11/32" (11 cm)
40" (102 cm)	32" (81 cm)	24" (61 cm)	3'9" (1.2 m)	4'4" (1.3 m)	2 57/64" (7 cm)

x : Screen diagonal size: 40" – 500"

L : Projection distance (ft/m)

L1: Minimum projection distance (ft/m)

L2: Maximum projection distance (ft/m)

H : Distance from the lens center to the bottom of the image (in/cm)

The formula for screen size and projection distance

[Feet/inches]

L1(ft) = 0.02882 x / 0.3048

L2(ft) = 0.03323 x / 0.3048

H (in) = 0.18358 x / 2.54

[m/cm]

L1(m) = 0.02882 x

L2(m) = 0.03323 x













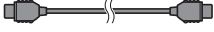
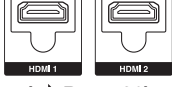

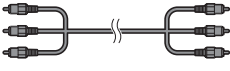
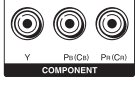
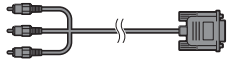

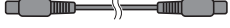

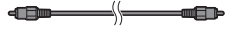

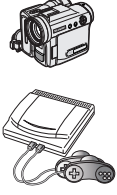
H (cm) = 0.18358 x

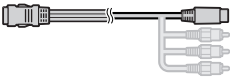

- Refer to page 16 concerning "Projection distance [L]" and "Distance from the lens center to the bottom of the image [H]".
- Allow a margin of error in the value in the diagrams above.

Samples of Cables for Connection

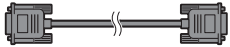
- For more details of connection and cables, refer to the operation manual of the connecting equipment.
- You may need other cables or connectors not listed below.

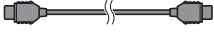
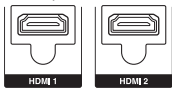
Equipment	Terminal on connected equipment	Cable	Terminal on the projector
Video equipment 	HDMI output terminal 	HDMI cable (commercially available) 	HDMI1, 2  (→ Page 20)
	Component video output terminal 	Component cable (commercially available) 	COMPONENT 
		3 RCA to mini D-sub 15 pin cable (optional, AN-C3CP2) 	COMPUTER/COMPONENT 
	S-video output terminal 	S-video cable (commercially available) 	S-VIDEO  (→ Page 20)
	Video output terminal 	Video cable (commercially available) 	VIDEO 
Camera/Video game 	Component video output terminal	Cables for a camera or a video game/3 RCA to mini D-sub 15 pin cable (optional, AN-C3CP2)  RCA adaptor plug (commercially available)	COMPUTER/COMPONENT 
	S-video output terminal	Cables for a camera or a video game 	S-VIDEO 
	Video output terminal	Cables for a camera or a video game 	VIDEO 
Computer 	RGB output terminal 	RGB cable (commercially available) 	COMPUTER/COMPONENT  (→ Page 21)
	HDMI output terminal 	HDMI cable (commercially available) 	HDMI1, 2 

Connecting to Video Equipment

Before connecting, be sure to unplug the power cord of the projector from the AC outlet and turn off the devices to be connected. After making all connections, turn on the projector and then the other devices.

Connecting Equipment with HDMI Output Terminal to the HDMI Terminal on the Projector

For video connection, use a cable that conforms to HDMI standards. Using cables that do not conform to HDMI standards may result in a malfunction.

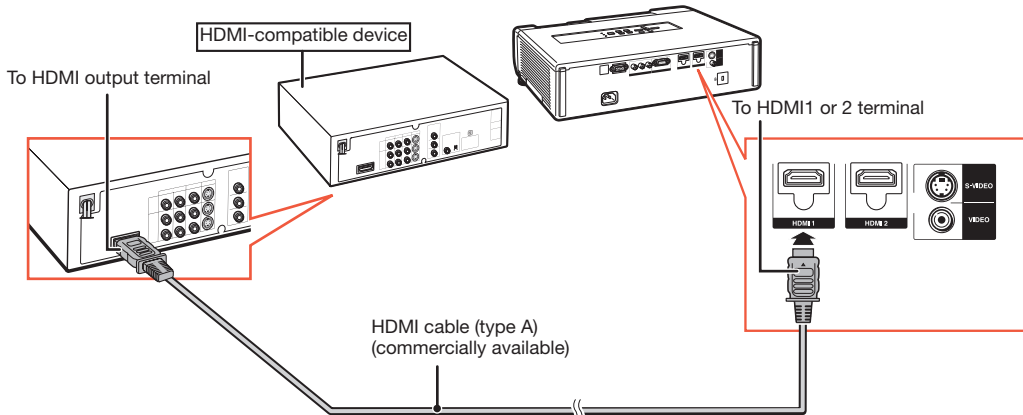

Note

- Depending on specifications of equipment or the DVI⇔HDMI digital cable, the signal transmission may not work properly. (The HDMI specification does not support all connections to equipment that has digital output terminal using a DVI⇔HDMI digital cable.)
- HDMI (High-Definition Multimedia Interface) is a digital AV interface that can deliver a high-definition video signal, multi-channel audio signal, and bi-directional control signal all in just one cable.
- Because it is compatible with the HDCP (High-bandwidth Digital Content Protection) system, the digital video signal does not degrade when transmitted, and a high-quality image with a simple connection can be enjoyed.

Connecting to Equipment with S-video Output Terminal

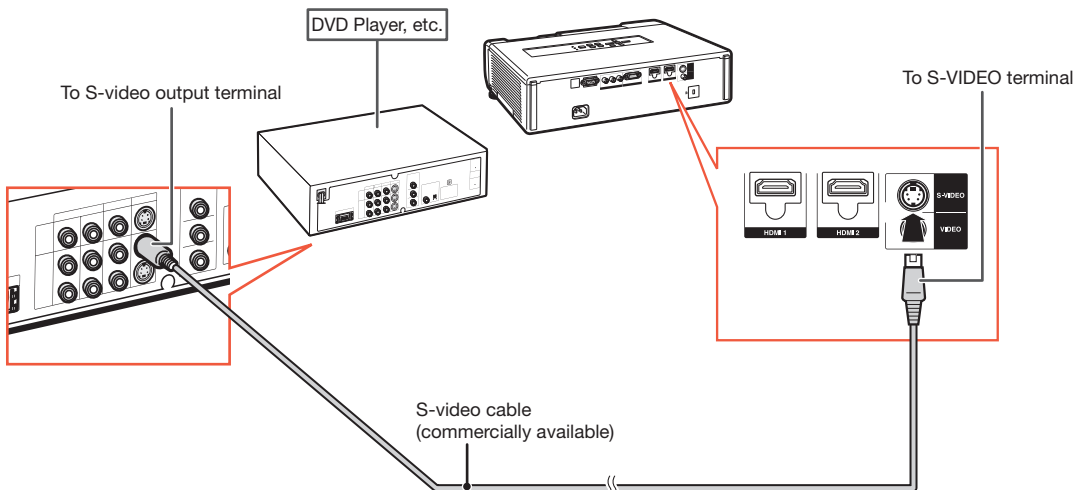

Refer to "Samples of Cables for Connection" on page 19 for connecting other equipment.

Connecting to a Computer

Ensure that the computer is the last device to be turned on after all the connections are made.

Connecting to a Computer Using the RGB Cable

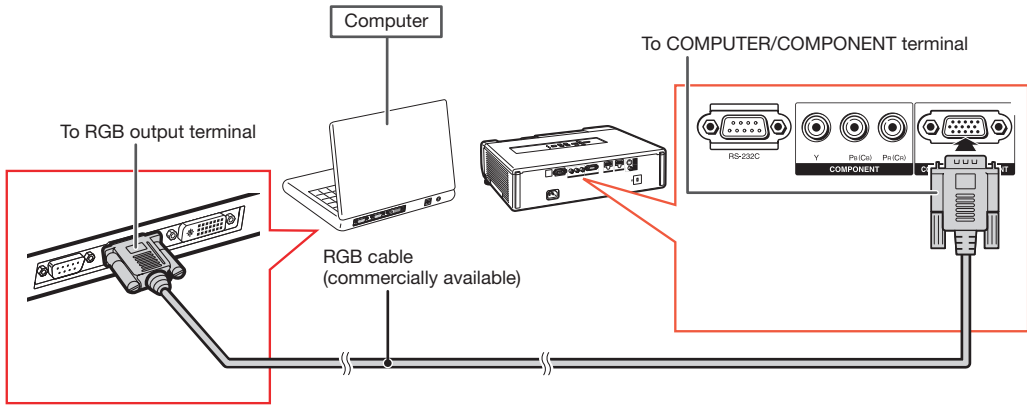

Note

- Refer to “Compatibility Chart” on page **70** for a list of computer signals compatible with the projector. Use with computer signals other than those listed may cause some of the functions not to work.
- A Macintosh adaptor may be required for use with some Macintosh computers. Contact your nearest Macintosh Dealer.
- **Depending on the computer you are using, an image may not be projected unless the computer’s external output port is switched on. (e.g. Press “Fn” and “F5” keys simultaneously when using a SHARP notebook computer).** Refer to the specific instructions in your computer’s operation manual to enable your computer’s external output port.

Controlling the Projector by a Computer

When the RS-232C terminal on the projector is connected to a computer, the computer can be used to control the projector and check the status of the projector.

When connecting to a computer using an RS-232C serial control cable

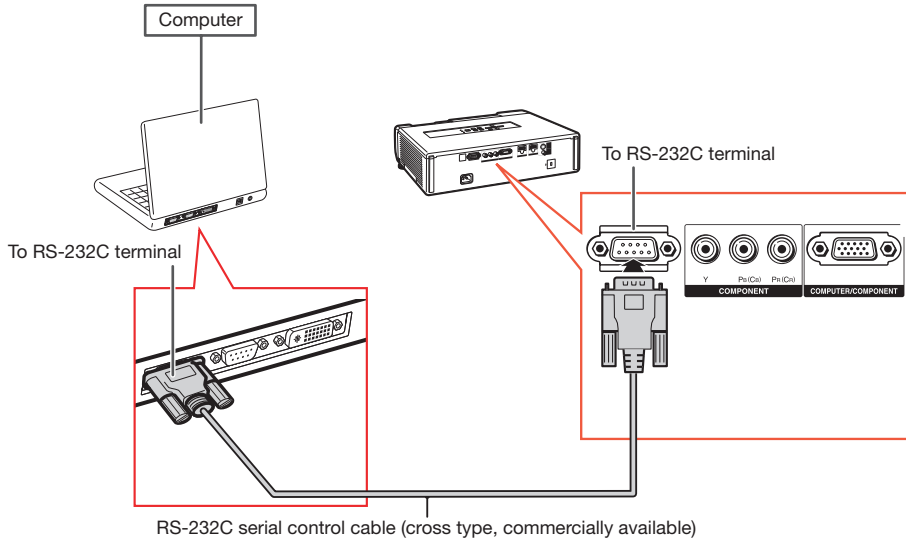

Note

- The RS-232C function may not operate if your computer terminal is not correctly set up. Refer to the operation manual of the computer for details.
- **For details on RS-232C specifications and commands, see page 66.**

Info

- Do not connect the RS-232C cable to a port other than the RS-232C terminal on the computer. This may damage your computer or projector.
- Do not connect or disconnect an RS-232C serial control cable to or from the computer while it is on. This may damage your computer.

Turning the Projector On/Off

Connecting the Power Cord

Plug the supplied power cord into the AC socket on the rear of the projector.

- The power indicator illuminates red, and the projector enters standby mode.

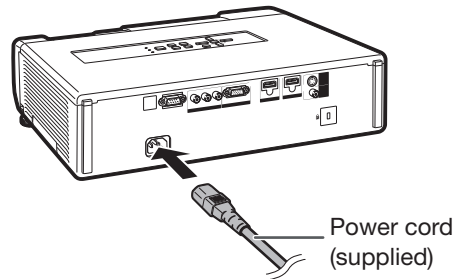

Turning the Projector On

Note that the connections to external equipment and power outlet should be done before performing the operations written below. (See pages 20 to 23.)

Open the lens shutter fully and press **STANDBY/ON** on the projector or **ON** on the remote control.

- The power indicator illuminates green.
- After the lamp indicator illuminates, the projector is ready to start operation.
- When the lens shutter is closed, the power indicator blinks alternately green and orange and the projector does not turn on.

Info

- English is the factory default language. If you want to change the on-screen display to another language, change the language according to the procedure on page 45.

Note

• About the Lamp Indicator

The lamp indicator illuminates to indicate the status of the lamp.

Green: The lamp is on.

Blinking in green: The lamp is warming up.

Red: The lamp is shut down abnormally or the lamp should be replaced.

- When switching on the projector, a slight flickering of the image may be experienced within the first minute after the lamp has been illuminated. This is normal operation as the lamp's control circuitry is stabilizing the lamp output characteristics. It should not be regarded as faulty operation.
- If the projector is put into standby mode and immediately turned on again, the lamp may take some time to start projection.

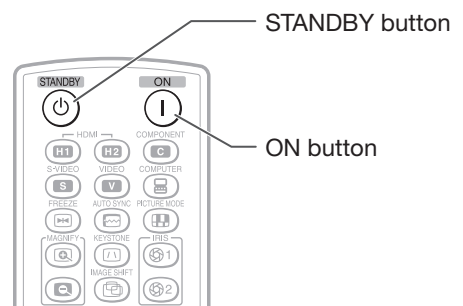
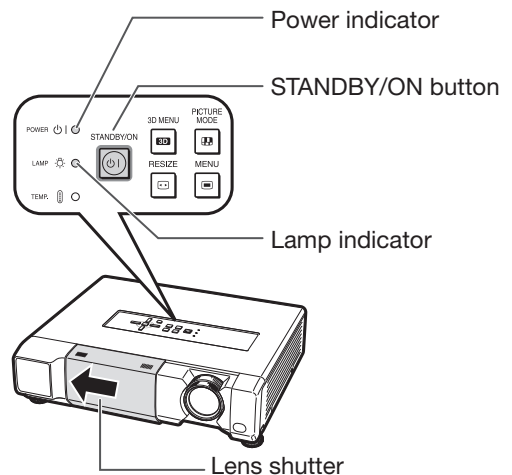

On-screen display

Enter STANDBY mode?
Yes : Press Again
No : Please Wait

Turning the Power Off (Putting the Projector into Standby Mode)

Press **STANDBY/ON** on the projector or **STANDBY** on the remote control, then press that button again while the confirmation message is displayed, to put the projector into standby mode.

- The projector cannot be turned on while cooling.

Info

• Direct Power Off function:

You can unplug the power cord from the AC outlet even if the cooling fan is still running.

Image Projection

Adjusting the Projected Image

1 Adjusting the Focus

You can adjust the focus with the focus ring on the projector.

Rotate the focus ring to adjust the focus while watching the projected image.

2 Adjusting the Picture Size

You can adjust the picture size using the zoom ring on the projector.

Rotate the zoom ring to enlarge or shrink the picture size.

3 Adjusting the Height

The height of the projector can be adjusted using the adjustment feet.

When the screen is above the projector, the projection image can be made higher by adjusting the projector.

1 Lift the projector to adjust its height while lifting the HEIGHT ADJUST lever.

2 Remove your hands from the HEIGHT ADJUST lever of the projector after its height has been finely adjusted.

- The angle of projection is adjustable up to 9 degrees from the surface on which the projector is placed.

Note

- When adjusting the height of the projector, trapezoidal distortion occurs. Follow the procedures in Keystone Correction to correct the distortion. (See pages 25 and 44.)

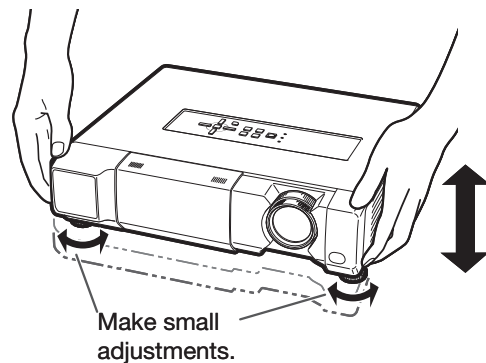
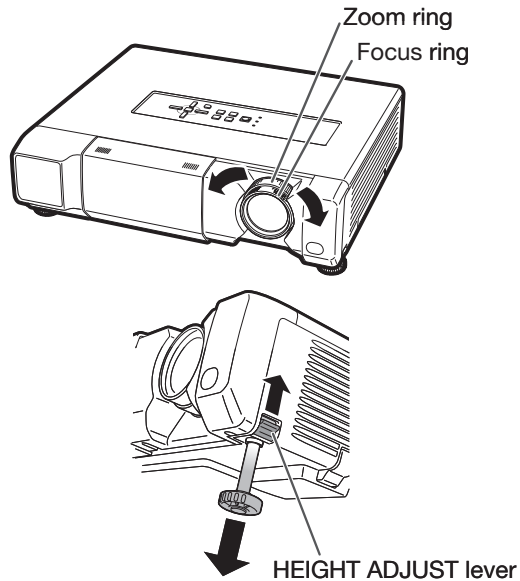

Info

- Do not apply too much pressure on the projector when the front adjustment feet come out.
- When lowering the projector, be careful not to get your fingers caught in the area between the adjustment feet and the projector.
- Hold the projector firmly while lifting or carrying.
- Do not hold by the lens area.

Keystone Correction

This function can correct distortion of an image projected toward a spherical or cylindrical screen as well as trapezoidal distortion of an image on a flat screen and rotate the image at your arbitrary angle.

■ Keystone

When the image is projected either from the top or from the bottom towards the screen at an angle, the image becomes distorted trapezoidally. The function for correcting trapezoidal distortion is called Keystone Correction.

Note

- The Keystone Correction can be adjusted up to an angle of approximately ± 40 degrees with “V-Keystone” and approximately ± 30 degrees with “H-Keystone”.

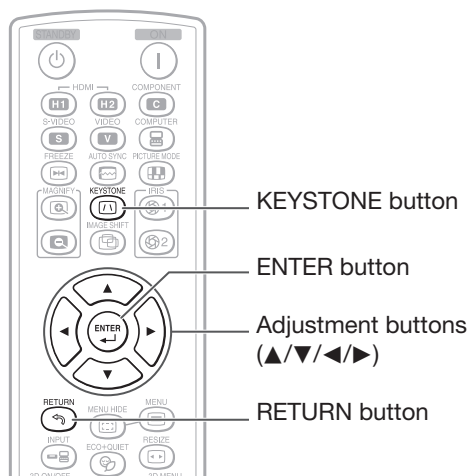

◀, ▶ button	For horizontal keystone correction
▲, ▼ button	For vertical keystone correction

1 Press **KEYSTONE** to enter the keystone mode.

- The keystone mode list appears.

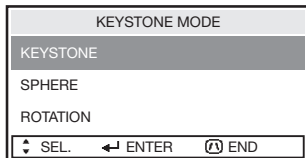

2 Press ▲/▼ to select “KEYSTONE”, and then press **ENTER**.

- The keystone menu guide appears.



Selectable buttons	Description
END → KEYSTONE	Exits the keystone mode.
ADJUST → ▲/▼/◀/▶	Adjusts the keystone correction.
TESTPATTERN → ENTER	Displays the testpattern.
RESET → RETURN	Returns to a default setting.

3 Press ▲/▼/◀/▶ to adjust the Keystone Correction.

Keystone Correction

H-Keystone Correction:



V-Keystone Correction:

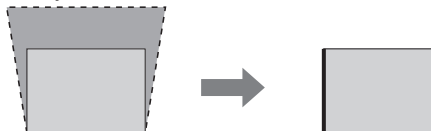

Note

- To return to the default setting, press **RETURN** while the on-screen display of the Keystone mode is on the screen.

Info

- While adjusting the image using Keystone/Sphere/Rotation Correction, straight lines and the edges of the image may appear jagged.

4 Press **KEYSTONE**.

- The on-screen display of the Keystone mode will disappear.

Image Projection (Continued)

■ Sphere

This function can correct distortion of an image projected toward a spherical or cylindrical screen.

1 Press **KEYSTONE** to enter the keystone mode.

- The keystone mode list appears. (See page 25.)

2 Press **▲/▼** to select “SPHERE”, and then press **ENTER**.

- The sphere menu guide appears.

Selectable items	Description
RETURN	Returns to the keystone mode list.
ADJUST	Adjusts the sphere correction.
TESTPATTERN	Displays the testpattern.
RESET	Returns to a default setting.

3 Press **▲/▼/◀/▶** to adjust the Sphere Correction mode.

▲, ▶ button	For correction of concave distortion
▼, ◀ button	For correction of convex distortion

Sphere Correction

Correction of Concave Distortion:



Correction of Convex Distortion:

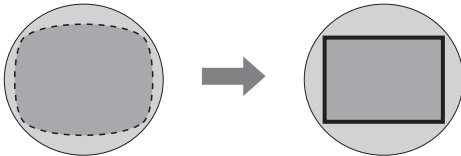

Note

- To return to the default setting, press **RETURN** while the on-screen display of the Keystone mode is on the screen.

4 Press **KEYSTONE**.

- The on-screen display of the Sphere Correction mode will disappear.

■ Rotation

This function rotates the image at an arbitrary angle.

1 Press **KEYSTONE** to enter the keystone mode.

- The keystone mode list appears. (See page 25.)

2 Press **▲/▼** to select “ROTATION”, and then press **ENTER**.

- The rotation menu guide appears.

Selectable items	Description
RETURN	Returns to the keystone mode list.
ADJUST	Adjusts the rotation correction.
TESTPATTERN	Displays the testpattern.
RESET	Returns to a default setting.

3 Press **▲/▼/◀/▶** to adjust the Rotation Correction mode.

▲, ▶ button	Rotates the image clockwise.
▼, ◀ button	Rotates the image counterclockwise.

Rotation Correction



Note

- To return to the default setting, press **RETURN** while the on-screen display of the Keystone mode is on the screen.

4 Press **KEYSTONE**.

- The on-screen display of the Rotation Correction mode will disappear.

Switching the Input Mode

Select the appropriate input mode for the connected equipment.

Press **HDMI 1, 2, COMPONENT, S-VIDEO, VIDEO** or **COMPUTER** on the remote control to select the input mode.

- When you press **INPUT** on the projector or on the remote control, the INPUT list appears.
- Press **▲/▼** to switch the INPUT mode.

INPUT list

INPUT
HDMI1
HDMI2
COMPONENT
COMPUTER
S-SVIDEO
VIDEO

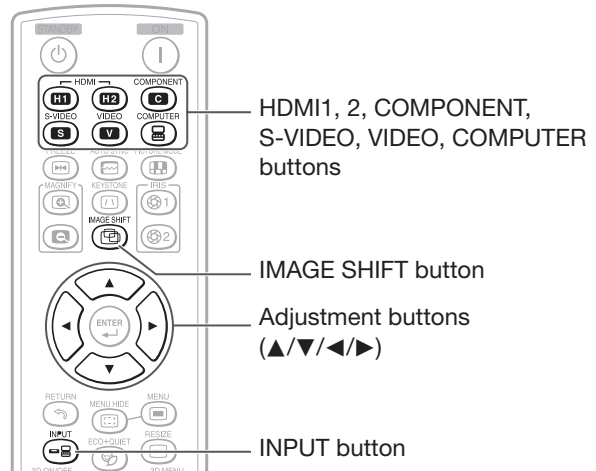

Note

- When you switch the INPUT mode, the image as shown below will be displayed in the upper right corner of the screen. (You can confirm the selected input mode and information on the input signal.)



- When is displayed, "3D" is set to "On".
- If is displayed, it means that a 3D image signal that can be automatically detected is being input.

Adjusting the Vertical and Horizontal Position of the Image

1 Press **IMAGE SHIFT** to enter the image shift mode.

- The image shift menu guide appears.



Selectable buttons	Description
END→ IMAGE SHIFT	Exits the image shift mode.
ADJUST→ ▲/▼/◀/▶	Adjusts the image shift.
RESET→ RETURN	Returns to a default setting.

2 Press **▲/▼/◀/▶** to adjust the vertical and horizontal position of the image.

H-Image Shift

Selectable items	◀ button	▶ button
H-Image Shift	Leftward	Rightward

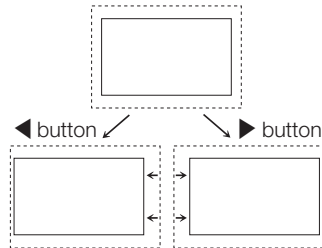

V-Image Shift

Selectable items	▼ button	▲ button
V-Image Shift	Downward	Upward

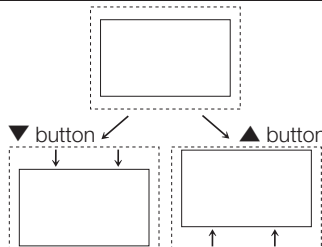

Note

- To return to the default setting, press **RETURN** when the image shift menu guide is still on the screen.
- The adjustable range of the image shift may vary depending on:
 - the Resize mode
 - the Picture mode
 - the input signal resolution
 - the input 3D signal type



Image Projection (Continued)

Displaying the Black Screen Temporarily

Close the lens shutter to temporarily display a black screen.

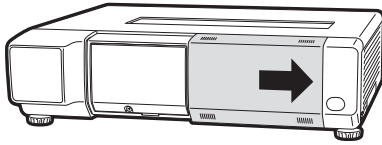

Note

- When you close the lens shutter, the projector will be turned off automatically after about 30 minutes.

Freezing a Moving Image

- 1 Press FREEZE.**
 - The projected image is frozen.
- 2 Press FREEZE again to return to the moving image from the currently connected device.**

Auto Sync (Auto Sync Adjustment)

Auto Sync function works when detecting input signal after the projector turns on.

Press AUTO SYNC to manually adjust with Auto Sync function.

Note

- When the optimum image cannot be achieved with Auto Sync adjustment, use manual adjustments. (See page 41.)

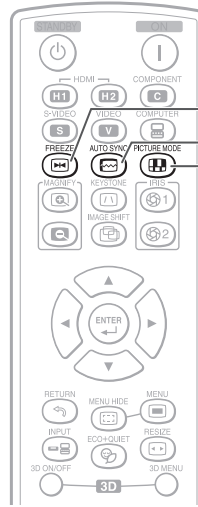

- FREEZE button
- AUTO SYNC button
- PICTURE MODE button

Selecting the Picture Mode

You can select the appropriate picture mode for the projected image, such as movie or video game.

Press PICTURE MODE.

- When pressing **PICTURE MODE**, the picture mode changes in the following order:

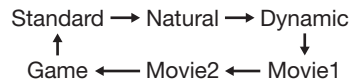

Note

- See page 37 for details on the picture mode.

Displaying an Enlarged Portion of an Image

Graphs, tables and other portions of projected images can be enlarged. This is helpful when providing more detailed explanations.

1 Press **MAGNIFY** on the remote control.

- Enlarges the image.
- Pressing **MAGNIFY** enlarges or reduces the projected image.

Note

Press **MAGNIFY**.

x1 x2 x3 x4 x9

Press **MAGNIFY**.

- You can change the location of the enlarged image using **UP**, **DOWN**, **LEFT** and **RIGHT**.

2 Press **RETURN** on the remote control to cancel the operation.

- To return to the default setting (x1), press **RETURN** when the on-screen display of the magnify mode is displayed.

Note

- The selectable magnifications differ depending on the input signal.
- This function is not available for the 3D mode.
- In the following cases, the image will return to the normal size (x1).
 - When switching the INPUT mode.
 - When **RETURN** has been pressed while the on-screen display of the magnify mode is displayed.
 - When the input signal is changed.
 - When the input signal resolution and refresh rate (vertical frequency) change.
 - When the Resize mode is changed.
 - When the Picture mode is changed.
 - When switching between 2D and 3D mode.

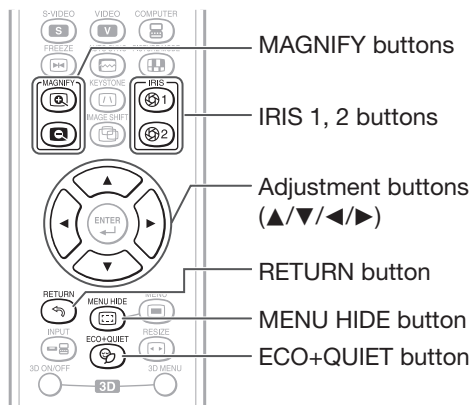

Switching the Iris Setting

This function controls the quantity of the projected light and the contrast of the image.

Press **IRIS 1** or **2**.

- Each time the button is pressed while the display is on, the mode changes in the following order:

- IRIS 1 High Brightness ↔ High Contrast
- IRIS 2 On ↔ Off

Note

- For details, see page 38.

Hiding the Menu Temporarily (Menu Hide)

When the menu screen is displayed, you can temporarily hide the menu screen by pressing and holding **MENU HIDE** on the remote control. This is useful when, for example, checking the video adjustment information.

Switching the Eco+Quiet Mode

Press **ECO+QUIET** to switch the Eco+Quiet mode between on and off.

- When the Eco+Quiet Mode is set to "On", the sound of the cooling fan will turn down, the power consumption will decrease, and the lamp life will extend.

Note

- Refer to "Eco+Quiet" on page 38 for details.

Image Projection (Continued)

Resize Mode

This function allows you to modify or customize the resize mode to enhance the input image.

Press **RESIZE** on the projector or on the remote control.

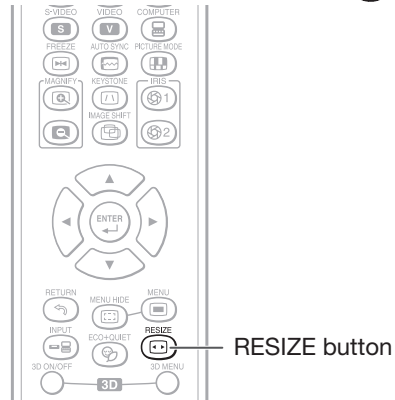
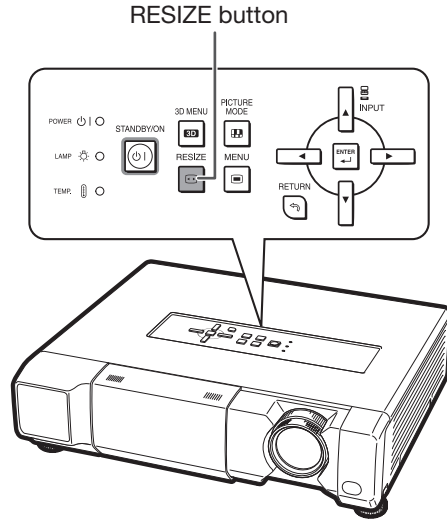

Note

- The **RESIZE** function that can be selected varies depending on the input signal (resolution and vertical frequency).



Resize Mode

RESIZE	Output screen image
NORMAL	<p>The image is displayed with the original aspect ratio.</p>
16:9	<p>An image compressed from a 16:9 aspect ratio to a 4:3 aspect ratio is restored to a 16:9 aspect ratio and displayed at full-screen.</p>
CINEMA ZOOM	<p>A CinemaScope image or an image with a 16:9 aspect ratio is displayed at full-screen</p>

RESIZE	Output screen image
ZOOM 14:9	<p>An image with a 14:9 aspect ratio and letterboxing is enlarged while maintaining the original aspect ratio.</p> 
SMART ZOOM	<p>An image with a 4:3 aspect ratio is slightly enlarged.</p> 
NATIVE	<p>The image is displayed according to the original input signal.</p> 

About Copyrights

- When using the RESIZE function to select an image size with a different aspect ratio to a TV program or video image, the image will look different from its original appearance. Keep this in mind while choosing an image size.
- The use of the RESIZE or Overscan function to compress or stretch the image for commercial purposes/public displays in a café, hotel, etc. may be an infringement of copyright protected by law for copyright holders. Please use caution.



Menu Bar Items

The following shows the items that can be set in the projector.
The selectable items vary depending on the selected input, input signals, or adjustment values. Items that cannot be selected will be grayed out.

“Picture” menu

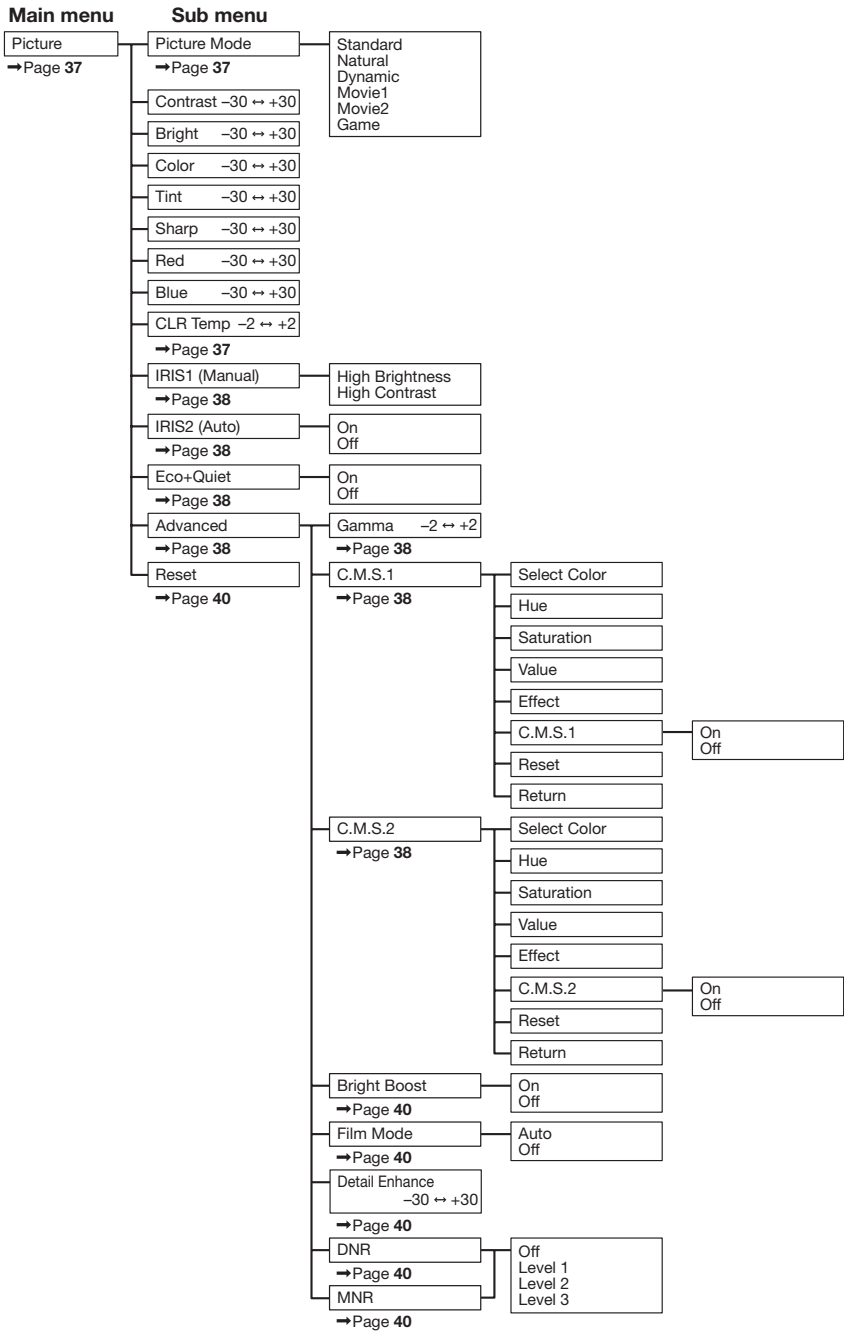

“SIG-ADJ” menu

Main menu	Sub menu
SIG-ADJ →Page 41	<ul style="list-style-type: none"> Clock -150 ↔ +150 →Page 41 Phase -30 ↔ +30 →Page 41 H-Pos -150 ↔ +150 →Page 41 V-Pos -60 ↔ +60 →Page 41 Reset Resolution →Page 41 Auto Sync →Page 41 Signal Type →Page 41 Video System →Page 42 Video Setup →Page 42 Dynamic Range →Page 42 Signal Info : →Page 42
	<ul style="list-style-type: none"> On Off Auto RGB YPbPr Auto PAL SECAM NTSC4.43 NTSC3.58 PAL-M PAL-N PAL-60 0 IRE 7.5 IRE Auto Standard Enhanced

“SCR-ADJ” menu

Main menu	Sub menu
SCR-ADJ →Page 43	<ul style="list-style-type: none"> Resize →Page 43 H-Image Shift -30 ↔ +30 →Page 43 V-Image Shift -30 ↔ +30 →Page 43 Overscan →Page 43 Auto V-Keystone →Page 44 Keystone Mode →Page 44 H-Keystone -60 ↔ +60 →Page 44 V-Keystone -80 ↔ +80 →Page 44 Sphere -30 ↔ +30 →Page 44 Rotation -50 ↔ +50 →Page 45 OSD Display →Page 45 OSD Brightness →Page 45 Background →Page 45 Menu Position →Page 45 PRJ Mode →Page 45 Language →Page 45
	<ul style="list-style-type: none"> On Off Keystone Sphere Rotation On Off Standard Level 1 Level 2 Logo Blue None Center Upper Right Lower Right Upper Left Lower Left Front Ceiling + Front Rear Ceiling + Rear English Deutsch Español Nederlands Français Italiano Svenska Português Русский polski Magyar Türkçe عربي فارسي 汉语 한국어 日本語

Menu Bar Items (Continued)

“PRJ-ADJ” menu

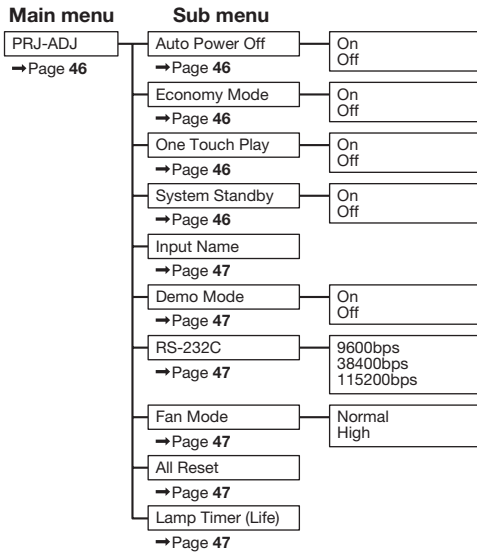

“3D MENU”

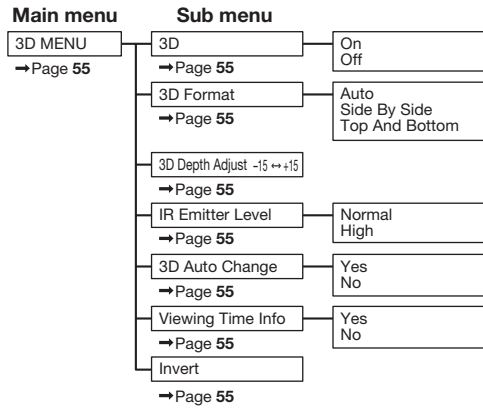

Using the Menu Screen

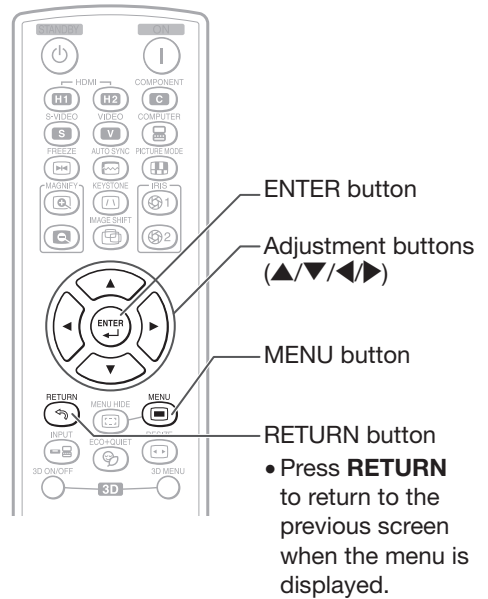
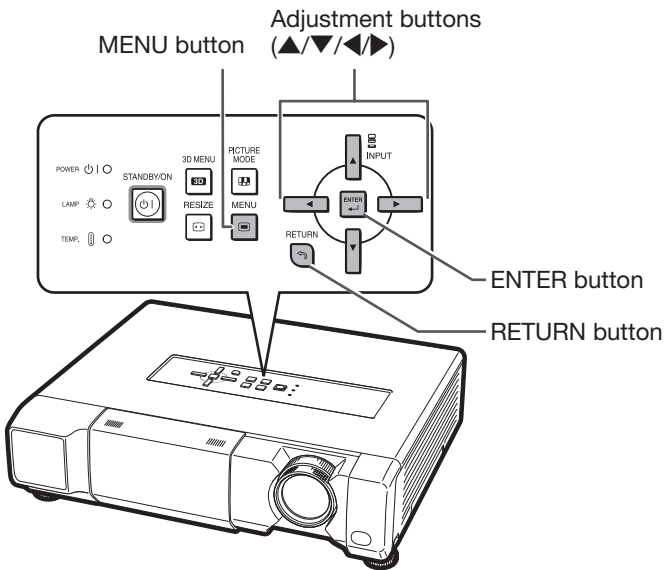

Menu Selections (Adjustments)

- This operation can also be performed by using the buttons on the projector.

1 Press **MENU**.

- The “Picture” menu screen for the selected input mode is displayed.

2 Press **▶** or **◀** to select the menu screen to adjust on the menu bar.

Example: “Picture” menu screen when **COMPONENT** is selected for input mode

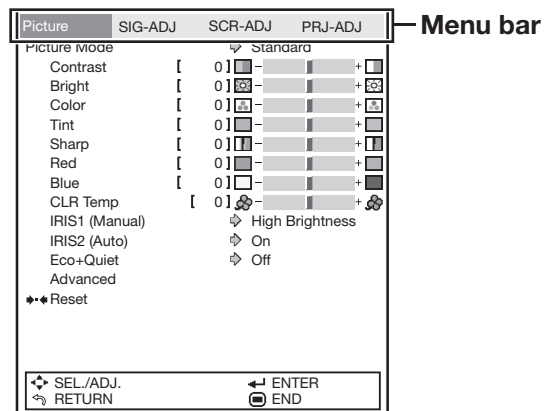

Using the Menu Screen (Continued)

3 Press ▲ or ▼ to select the item you want to adjust.
(Example: Selecting “Bright”)

To adjust the projected image while viewing it

Press **ENTER**.

- The selected adjustment item (e.g. “Bright”) will be displayed at the bottom of the screen.
- When ▲ or ▼ is pressed, the next item will be displayed. (e.g. “Bright” is replaced with “Color” by pressing ▼.)

Note

- Press **RETURN** to return to the previous screen.

4 Press ► or ◀ to adjust the item selected.

- The adjustment is stored.
- For some menu items, press ► to display its submenu and press ▲ or ▼ to select an adjustment item, and then press **ENTER**.

5 Press MENU.

- The menu screen will disappear.

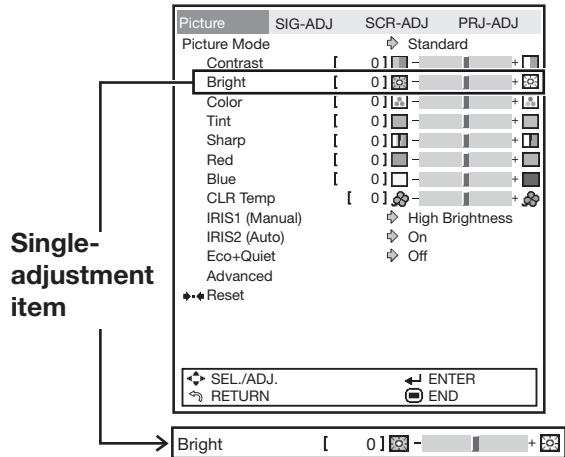

Picture Adjustment (“Picture” Menu)

Menu operation ⇒ Page 35

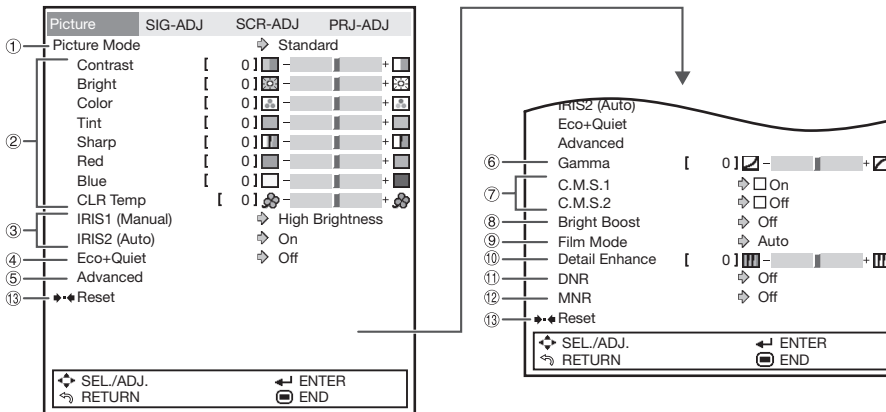

① Selecting the Picture Mode

This function allows you to select the picture mode that best suits the room brightness and the type of image being projected.

Selectable items	Description	The main default settings of each item when selecting Picture Mode				
		CLR Temp	Bright Boost	IRIS1 (Manual)	IRIS2 (Auto)	Eco+Quiet
Standard	For standard image	0	Off	High Brightness	On	Off
Natural	A balanced color image is obtained.	0	Off	High Brightness	Off	Off
Dynamic	A vivid image is obtained.	0	On	High Brightness	Off	Off
Movie1	For viewing images with the brightness slightly toned down in a darkened room	-1	Off	High Contrast	Off	On
Movie2	For viewing images with the brightness slightly boosted in a darkened room	-1	Off	High Contrast	On	On
Game	Use this when the audio and image are not synched or when you want to create a sharper image.	0	On	High Brightness	Off	Off

- You can set or adjust each item in the “Picture” menu to your preference. Any changes you make are retained in memory.

Note

- You can also press **PICTURE MODE** on the remote control to select the picture mode. (See page 28.)
- The default settings are subject to change without notice.

② Adjusting the Image

Adjustment items	◀ button	▶ button
Contrast	For less contrast.	For more contrast.
Bright	For less brightness.	For more brightness.
Color	For less color intensity.	For more color intensity.
Tint	For making skin tones purplish.	For making skin tones greenish.
Sharp	For less sharpness.	For more sharpness.
Red	For making images less reddish.	For making images more reddish.
Blue	For making images less bluish.	For making images more bluish.
CLR Temp	For making images slightly more reddish (slightly warmer colors).	For making images slightly more bluish (slightly cooler colors).

Picture Adjustment (“Picture” Menu) (Continued)

Menu operation ⇒ Page 35

③ Switching the Iris Setting

This function controls the quantity of the projected light and the contrast of the image.

■ IRIS1 (Manual)

Selectable items	Description
High Brightness	This mode gives priority to brightness over contrast.
High Contrast	This mode gives priority to contrast over brightness.

■ IRIS2 (Auto)

This automatically selects the optimal contrast to match the image.

Selectable items	Description
On	This mode gives priority to contrast with the use of auto adjustment.
Off	This mode gives priority to brightness without the use of auto adjustment.



Note

- You can also use **IRIS 1, 2** on the remote control to change the Iris. (See page 29.)

④ Eco+Quiet

Selectable items	Brightness and Power consumption
On	Approx. 75%
Off	100%



Note

- When “Eco+Quiet” is set to “On”, the power consumption will decrease and the lamp life will extend. (Projection brightness decreases approximately 25%.)

⑤ Using the Advanced

“Advanced” allows you to make even finer adjustments to the image so that it appears just the way you want it to.

To display the Advanced menu, select “Advanced” and press **ENTER**.



Note

- When the “Advanced” settings are displayed, select “Advanced” again and press **ENTER** to return to the “Picture” menu.

⑥ Correcting Gradation of Video (Gamma Correction)

When the darker areas of the image become difficult to see because of the image or the projection environment, you can correct the gamma setting to make the image brighter and easier to see.

Selectable items	Description
+2	Provides a brighter gradation.
+1	
0	Standard setting
-1	Provides a darker gradation.
-2	

⑦ Adjusting the Colors

You can select the color of the projected image to correct and then adjust it to the desired color by setting “Hue”, “Saturation”, “Value”, and “Effect”.



Note

- Before performing this adjustment, prepare the image to be adjusted.
- You can perform this adjustment easier in the still image than in the moving image.

1 Select “C.M.S.1” or “C.M.S.2” (C.M.S.: Color Management System) in the “Advanced” menu, and press **ENTER**.

- If there is no data for the stored corrected color, the color selection screen and the picker is displayed. (Go to step 2.)

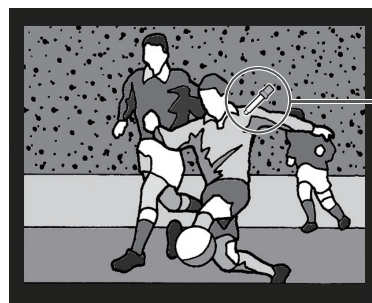

Picker

- If there is data for the stored corrected color, the C.M.S. color adjustment screen is displayed. (Go to step 3.)

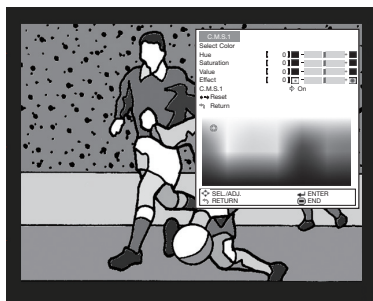

2 Use the picker and select the color of the projected image to correct. The picker can be operated by adjustment buttons (▲/▼/◀/▶) on the remote control.

- By enlarging the projected image using or **MAGNIFY**, more fine adjustment can be performed.



- By continuing to press the adjustment buttons (▲/▼/◀/▶), the picker moves rapidly.

After selecting the color of the projected image to correct, press **ENTER**. The C.M.S. color adjustment screen is displayed. (Go to step 3.)

3 Set or adjust each item in the C.M.S. color adjustment screen.

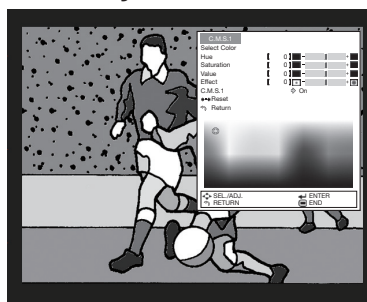

C.M.S. color adjustment screen:

Selectable items	Description
Select Color	Starts over the selection of the color to be corrected.
Hue	Sets the hue of the main colors.
Saturation	Sets the saturation of the main colors.
Value	Sets the value of the main colors.
Effect ^{*1}	Specifies the range of color correction.
C.M.S.1 ^{*2} (or C.M.S.2)	Checks the appearance of the projected image after above correction.
Reset	Sets "Hue", "Saturation", "Value", and "Effect" to their default values.
Return	Completes the correction and closes the C.M.S. color adjustment screen.

^{*1} To specify the range of color correction, select "Effect" and press ◀ or ▶ button.

◀ button	Specifies smaller range.
▶ button	Specifies larger range.

^{*2} To check the appearance of the projected image, select "C.M.S.1" (or "C.M.S.2") and set to "On" or "Off".

On	The appearance of the projected image after above color adjustment reflected can be checked.
Off	The appearance of the projected image in former color adjustment can be checked.

4 To complete the C.M.S. color adjustment, select "Return" and press **ENTER**.

Note

- The C.M.S. color adjustment can be made to one color each in "C.M.S.1" and "C.M.S.2".

Picture Adjustment (“Picture” Menu) (Continued)

Menu operation ⇒ Page 35

⑧ Adjusting the Bright Boost

Bright Boost uses Texas Instruments’ Bright Boost technology. The image becomes brighter while the color reproduction is kept at a high level.

Selectable items	Description
On	The Bright Boost function is activated.
Off	The Bright Boost function is not activated.

⑨ Selecting the Film Mode

This function provides high-quality playback of images originally projected at 24 fps, such as movies on DVDs.

Selectable items	Description
Auto	Films are detected automatically.
Off	Films are not detected.

⑩ Setting Detail Enhancement

This function enhances the details in images and, thereby, creates a greater sense of depth.

◀ button	Provides less detail enhancement.
▶ button	Provides more detail enhancement.

⑪ Reducing Image Noise (DNR)

Video digital noise reduction (DNR) provides high quality images with minimal dot crawl and cross color noise.

Selectable items	Description
Off	The DNR function is not activated.
Level 1	Sets the DNR level for viewing a clearer picture.
Level 2	
Level 3	

Note

- Set “DNR” to “Off” in the following cases:
 - When the image is blurry.
 - When the contours and colors of moving images drag.
 - When TV broadcasts with weak signals are projected.
- This function is available for the following signals.
With S-VIDEO or VIDEO input:
 - 480I/480P
 - 576I/576P

⑫ Mosquito Noise Reduction (MNR)

The so-called Mosquito Noise (flickering) can be reduced.

Selectable items	Description
Off	MNR does not function.
Level 1	Sets the MNR level for viewing a clearer picture.
Level 2	
Level 3	

Note

- Set “MNR” to “Off” in the following cases:
 - When the image is blurry.
 - When the contours and colors of moving images drag.
 - When TV broadcasts with weak signals are projected.
- This function is available for the following signals.
With S-VIDEO or VIDEO input:
 - 480I/480P
 - 576I/576P

⑬ Resetting All Adjustment Items

To reset all adjustment items to the default settings, select “Reset” and press **ENTER**.

Computer Image Adjustment (“SIG-ADJ” Menu)

The illustration shown here is for explanation and may be different from the actual on-screen display.

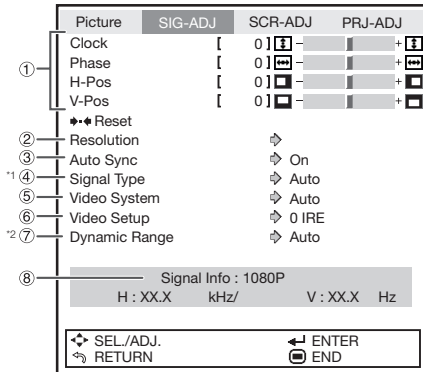

*1 If the input mode is S-VIDEO or VIDEO input, the display changes to the “Video System” screen.

*2 Displayed when the input mode is HDMI input.

① Adjusting the Computer Image

Use the SIG-ADJ function in case of irregularities such as vertical stripes or flickering in portions of the screen.

Selectable items	Description
Clock	Adjusts vertical noise.
Phase	Adjusts horizontal noise (similar to tracking on your VCR).
H-Pos	Centers the on-screen image by moving it to the left or right.
V-Pos	Centers the on-screen image by moving it up or down.

Note

- You can automatically adjust the computer image by setting “Auto Sync” in the “SIG-ADJ” menu to “On”, or pressing **AUTO SYNC** on the remote control.
- Depending on the type of input signal, the adjustment range for each setting may vary or the adjustment may not be available at all.
- To reset all adjustment items, select “Reset” and press **ENTER**.

② Setting the Resolution

Ordinarily, the type of input signal is detected and the correct resolution mode is automatically selected. However, for some signals, the optimal resolution mode in “Resolution” in the “SIG-ADJ” menu may need to be selected to match the computer display mode.

Note

- Avoid displaying computer patterns which repeat every other line (horizontal stripes). (Flickering may occur, making the image hard to see.)
- Information on the currently selected input signal can be confirmed in item ⑧ on page 42.

③ Auto Sync (Auto Sync Adjustment)

Selectable items	Description
On	Auto Sync adjustment will occur when the projector is turned on or when the input signals are switched, when connected to a computer.
Off	Auto Sync adjustment is not automatically performed.

Note

- Auto Sync adjustment is also performed by pressing **AUTO SYNC** on the remote control.
- When setting “Auto Sync” to “Off”, and if **AUTO SYNC** is pressed, Auto Sync will be executed in “On” mode. If the button is pressed again within one minute, Auto Sync will be executed in “On” mode.
- The Auto Sync adjustment may take some time to complete, depending on the image of the computer connected to the projector.
- When the optimum image cannot be achieved with Auto Sync adjustment, use manual adjustments.

④ Signal Type Setting

When using an input mode of HDMI1, HDMI2, or COMPUTER, set the signal type to the corresponding input signal type (RGB or YPbPr).

Selectable items	Description
Auto	Automatically selects the appropriate input signal between RGB and YPbPr.
RGB	Set when RGB signals are received.
YPbPr	Set when YPbPr signals are received.

Computer Image Adjustment (“SIG-ADJ” Menu) (Continued)

Menu operation ⇒ Page 35

⑤ Setting the Video System

The video input system mode is factory preset to “Auto”; however, a clear picture from the connected audio-visual equipment may not be received, depending on the video signal difference. In that case, switch the video signal.

Selectable items
Auto
PAL
SECAM
*NTSC4.43
NTSC3.58
PAL-M
PAL-N
PAL-60

* When reproducing NTSC signals in PAL video equipment.

Note

- The video signal can only be set in VIDEO or S-VIDEO mode.
- When “Video System” is set to “Auto”, you may not receive a clear picture due to signal differences. Should this occur, switch to the video system of the source signal.

⑥ Setting the Video Setup

Selectable items	Description
0 IRE	Sets the black level to 0 IRE.
7.5 IRE	Sets the black level to 7.5 IRE.

Note

- This function is available for the following signals.
With COMPONENT or COMPUTER/
COMPONENT input:
 - 480IWith S-VIDEO or VIDEO input:
 - NTSC3.58

⑦ Adjusting the Dynamic Range

An optimum picture may not be displayed if an HDMI-capable device’s output signal type and the projector’s input signal type do not match. If this should occur, switch “Dynamic Range”.

Selectable items	Description
Auto	In most circumstances, “Auto” should be selected.
Standard	When the black levels of the image show banding or appear faded, select the item that results in the best picture quality.
Enhanced	

⑧ Signal Info

Input signal information is displayed.

Adjusting the Projected Image (“SCR-ADJ” Menu)

Menu operation ⇒ Page 35

The illustration shown here is for explanation and may be different from the actual on-screen display.

	Picture	SIG-ADJ	SCR-ADJ	PRJ-ADJ
①	Resize		⇨ Normal	
②	H-Image Shift	[0]	⇨	⇩
②	V-Image Shift	[0]	⇨	⇩
③	Overscan		⇨ On	
④	Auto V-Keystone		⇨ Keystone	
④	Keystone Mode		⇨ Keystone	
⑤	H-Keystone	[0]	⇨	⇩
⑤	V-Keystone	[0]	⇨	⇩
⑤	Sphere	[0]	⇨	⇩
⑤	Rotation	[0]	⇨	⇩
⑥	OSD Display		⇨ On	
⑦	OSD Brightness		⇨ Standard	
⑧	Background		⇨ Logo	
⑨	Menu Position		⇨ Upper Left	
⑩	PRJ Mode		⇨ Front	
⑪	Language		⇨ English	
			⇨ SEL./ADJ. ⇨ RETURN	⇨ ENTER ⇨ END

① Setting the Resize Mode

Note

- For details of the Resize mode, see page 30.
- You can also press **RESIZE** on the remote control to set the resize mode. (See page 30.)

② Adjusting the Image Position

You can move the projected image horizontally or vertically.

■ H-Image Shift

Selectable items	◀ button	▶ button
H-Image Shift	Leftward	Rightward

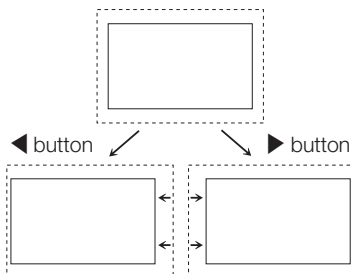

■ V-Image Shift

Selectable items	◀ button	▶ button
V-Image Shift	Downward	Upward

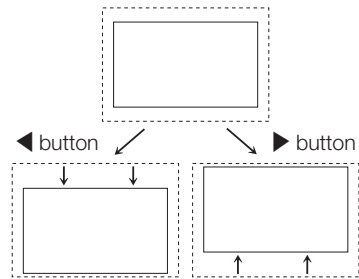

Note

- The adjustable range of the image shift may vary depending on:
 - the Resize mode
 - the Picture mode
 - the input signal resolution
 - the input 3D signal type

③ Adjusting the Overscan

This function allows you to adjust the Overscan area (display area).

Selectable items	Description
On	The input area is displayed without screen edges.
Off	The whole input area is displayed.

Note

- You can adjust the Overscan area for the following input signals and the RESIZE function.
 - Input signal:
 - 480I/480P
 - 540P
 - 576I/576P
 - 720P
 - 1035I
 - 1080I/1080P
 - RESIZE function:
 - NORMAL
 - 16:9
 - CINEMA ZOOM
 - ZOOM 14:9
- If the display area ratio is set too large, noise may appear at the screen edges. If this happens, set the display area ratio to a smaller value.
- Also read “About Copyrights” on page 31.

Adjusting the Projected Image (“SCR-ADJ” Menu) (Continued)

Menu operation ⇒ Page 35

④ Auto V-Keystone Correction

Select “Auto V-Keystone” in the “SCR-ADJ” menu and press **ENTER**. Vertical keystone correction is performed automatically.

Note

- Pressing **ENTER** when the on-screen display of the Auto V-Keystone “On” appears changes the setting of the Auto V-Keystone to “Off”.
- The Keystone Correction can be adjusted up to an angle of approximately ± 12 degrees with “Auto V-Keystone”.
- For details of Keystone mode, see page 25.

Auto V-Keystone Correction

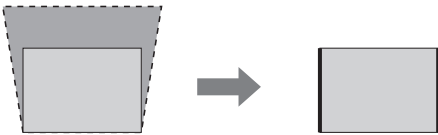

⑤ Keystone Mode Correction

This function can correct distortion of an image projected toward a spherical or cylindrical screen as well as trapezoidal distortion of an image on a flat screen and rotate the image at your arbitrary angle.

Note

- For details of Keystone mode, see page 25.

Info

- While adjusting the image using Keystone/ Sphere/Rotation Correction, straight lines and the edges of the image may appear jagged.

Select “Keystone Mode” in the “SCR-ADJ” menu and press **ENTER**. Then select a desired item among “Keystone”, “Sphere”, or “Rotation” and press **ENTER**. “Keystone” has been set as a default setting in which you can adjust “H-Keystone” and “V-Keystone”.

Keystone

H-Keystone:

◀ or ▶	Makes the upper and lower sides parallel.
--------	---

Horizontal Keystone Correction



V-Keystone:

◀ or ▶	Makes the left and right sides parallel.
--------	--

Vertical Keystone Correction

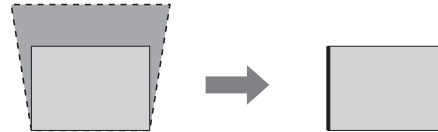

Sphere

This function corrects screen distortion created during spherical or cylindrical screen projection.

◀ button	Narrower at the center
▶ button	Wider at the center

Sphere Correction

Correction of Convex Distortion:

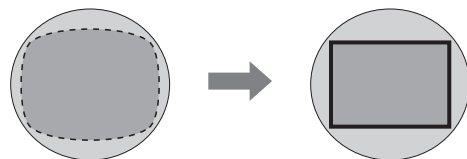

Correction of Concave Distortion:



■ Rotation

This function can rotate the image at an arbitrary angle.

◀ button	Rotates the image counterclockwise.
▶ button	Rotate the image clockwise.

Rotation Correction



⑥ Setting On-screen Display

Selectable items	Description
On	All on-screen displays are displayed.
Off	INPUT/FREEZE/AUTO SYNC/RESIZE/PICTURE MODE/ECO+QUIET/MAGNIFY/3D ON/OFF (3D/2D mode change) message are not displayed.

⑦ Setting the Brightness of the Menu Screen

Sets the brightness of the menu screen.

Selectable items	Description
Standard	Standard brightness
Level 1	Darker than the "Standard" brightness
Level 2	Darker than the "Level 1" brightness

⑧ Selecting the Background Image

Selectable items	Description
Logo	SHARP logo screen
Blue	Blue screen
None	— (Black screen)

⑨ Selecting the Menu Screen Position

Select "Menu Position" in the "SCR-ADJ" menu and the desired position for the menu screen.

Selectable items	Description
Center	Displayed on the center of the image.
Upper Right	Displayed on the upper right of the image.
Lower Right	Displayed on the lower right of the image.
Upper Left	Displayed on the upper left of the image.
Lower Left	Displayed on the lower left of the image.

⑩ Reversing/Inverting Projected Images

This function allows the projector to be used in a wider range of projection styles by allowing the image to be inverted to suit the projection environment (location).

Selectable items	Description
Front	Normal image (Projected from the front of the screen)
Ceiling + Front	Inverted image (Projected from the front of the screen with an inverted projector)
Rear	Reversed image (Projected from the rear of the screen or with a mirror)
Ceiling + Rear	Reversed and inverted image (Projected with a mirror)

See page 17 for details of Projection (PRJ) Mode.

⑪ Selecting the On-screen Display Language

The projector can switch the on-screen display language among 17 languages.

English
 Deutsch
 Español
 Nederlands
 Français
 Italiano
 Svenska
 Português
 Русский
 polski
 Magyar
 Türkçe
 عربي
 فارسی
 汉语
 한국어
 日本語

Adjusting the Projector Function (“PRJ-ADJ” Menu)

The illustration shown here is for explanation and may be different from the actual on-screen display.

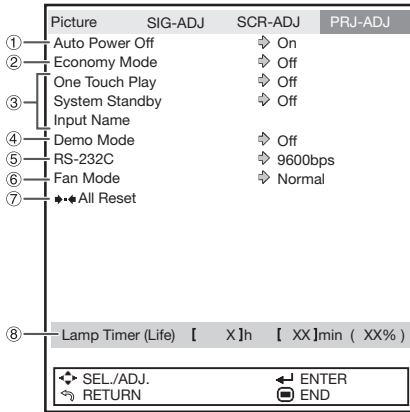

① Setting Auto Power Off Mode

This function automatically switches the projector to Standby mode if no signals are received for a set period.

Selectable items	Description
On	When no input signal is detected for more than 15 minutes, the projector will automatically enter standby mode.
Off	The Auto Power Off function will be disabled.

Note

- When the Auto Power Off function is set to “On”, 5 minutes before the projector enters standby mode, the message “Enter STANDBY mode in X min.” will appear on the screen to indicate the remaining minutes.

② Setting the Power Save Mode (Economy Mode)

■ Economy Mode

Selectable items	Description
On	This enables the Economy mode.
Off	You can use the linked functions. RS-232C can be used to control the projector in standby mode.

Note

- Set this function to “Off” when you want to use RS-232C to control the projector from a computer.
- One Touch Play is set to “Off” when the Economy mode is set to “On”.

③ Setting One Touch Play, System Standby and Input Name

When a Sharp product equipped with Consumer Electronics Control (HDMI CEC) is connected to the projector with an HDMI cable, you can use the linked function with HDMI CEC (“One Touch Play” and “System Standby”).

Note

The CEC function may not work with some CEC devices. (When the projector is connected to a non-Sharp product, the CEC function may not work.)

■ Setting the One-Touch Playback Function (One Touch Play)

One Touch Play turns on the projector and selects the input automatically when you turn on or begin playback on connected HDMI-compliant Sharp Video Products.

Selectable items	Description
On	This enables One Touch Play.
Off	This disables One Touch Play.

Note

- When enabling One Touch Play, be sure to enable the CEC setting on the HDMI-compliant Sharp Video Products connected to the projector.
- The Economy mode is set to “Off” when One Touch Play is set to “On”.
- In the following cases, One Touch Play is not enabled.
 - When playback is paused
 - When the screen is turned off (black) after the lens shutter is closed
 - When the cooling fan is running (See page 60.)
 - When the lamp is warming up (See page 60.)

■ Setting the System Standby Function (System Standby)

When you turn off the projector, the HDMI-compliant video equipment connected to the projector enters standby mode.

Selectable items	Description
On	This enables System Standby.
Off	This disables System Standby.

Note

- When enabling System Standby, be sure to enable the CEC setting on the HDMI-compliant Sharp Video Products connected to the projector.

■ Setting the Input Terminal Names (Input Name)

Set the name of the input terminal (up to 14 alphanumeric characters).

1 Press ▲/▼ to select “Input Name” and then press ENTER.

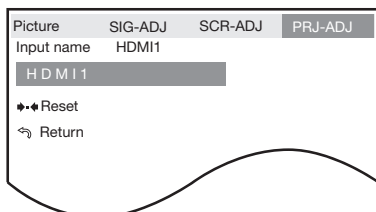

◀ or ▶ button	Selects a character column.
▲ or ▼ button	Selects a character.
ENTER button	Sets the input terminal name.

2 Press ▲/▼ to select “Return” and then press ENTER to return to the previous screen.

- To return to the previous setting, select “Reset” and then press ENTER.

Note

- When connecting the projector to a Sharp Video Product with an HDMI cable using an input mode of HDMI1 or HDMI2 and the linked function with HDMI CEC (“One Touch Play” or “System Standby”) works normally, the name of the connected Sharp Video Product is automatically captured.
- When the input terminal name has been changed by a user, the changed name is displayed.
- To return to the default name, select “Reset” and press ENTER.

④ Setting the Demo Mode

Set the Demo Mode to “On” or “Off”.

Selectable items	Description
On	This enables Demo Mode.
Off	This disables Demo Mode.

⑤ Selecting the Transmission Speed (RS-232C)

Make sure that both the projector and computer are set for the same baud rate.

Selectable items	Description
9600bps	Transmission speed is slow.
38400bps	↕
115200bps	Transmission speed is rapid.

⑥ Fan Mode Setting

This function changes the fan rotation speed.

Selectable items	Description
Normal	Suitable for normal environments.
High	Select this when using the projector at altitudes of approximately 4,900 feet (1,500 meters) or more.

- When “Fan Mode” is set to “High”, the fan rotation speeds up, and the fan noise becomes louder.

⑦ Returning to the Default Settings

Use “All Reset” to initialize all the adjustments you have made to the default settings.

Note

The following items cannot be initialized.

- “SIG-ADJ” menu — Resolution
- “SCR-ADJ” menu — Language
- “PRJ-ADJ” menu — Lamp Timer (Life)

⑧ Lamp Timer (Life)

You can confirm the cumulative lamp usage time and the remaining lamp life (percentage).

Lamp usage condition	Remaining lamp life		
	“Life”	100%	5%
Operated exclusively with “Eco+Quiet” set to “On”	Approx. 3,000 hours	Approx. 150 hours	Approx. 150 hours
Operated exclusively with “Eco+Quiet” set to “Off”	Approx. 2,000 hours	Approx. 100 hours	Approx. 100 hours

Note

- It is recommended that the lamp be changed when the remaining lamp life becomes 5%.
- The lamp life may vary depending on the usage condition.

Enjoying 3D Image Viewing

CAUTION: Before viewing 3D images, please read this section carefully.

You can use special 3D Glasses to watch 3D-supported images on this projector.

- You can enjoy 3D images by viewing the video images through the 3D Glasses supplied with the projector or through optional 3D glasses sold separately.
- To produce 3D images, liquid crystal shutters in the 3D Glasses alternately open and close imperceptibly fast to exactly match alternating left and right video images displayed by the projector.
- Not all consumers can experience and enjoy 3D images. Some people suffer from stereo blindness which prevents them from perceiving the intended depth of 3D entertainment. Also, some people who watch 3D programming may experience initial feelings of motion sickness as they adjust to the picture. Others may experience headaches, eye fatigue or continued motion sickness. Like a roller coaster, the experience is not for everyone.

Precautions on using 3D Glasses

- The 3D Glasses are precision equipment. Handle them with care.
- Improper use of the 3D Glasses or failure to follow these instructions can result in eye strain.
- If you experience dizziness, nausea, or other discomfort while viewing 3D images, immediately discontinue use of the 3D Glasses. Using the binocular disparity 3D system of this projector with incompatible 3D broadcasts or software can make images appear with a cross talk blur or create overlapping images.
- If you are nearsighted or farsighted or have astigmatism or a different level of eyesight between the left and right eyes, you should take the necessary steps, such as wearing eyeglasses, to correct your eyesight before viewing 3D images. The 3D Glasses can be worn over eyeglasses.
- 3D viewing is possible within the range that the 3D Glasses are able to receive infrared signals reflected by the screen. However, most 3D images are manufactured to be viewed from directly in front of the screen, so 3D viewing is recommended directly in front of the screen as much as possible.
- The 3D Glasses are only recommended for people ages 5 and older.
- When children are viewing 3D images, be sure a parent or guardian is present. Monitor children viewing 3D images, and if they show signs of discomfort, immediately discontinue use of the 3D Glasses.

- People with a known history of photosensitivity and people with heart problems or poor health should not use the 3D Glasses. This can worsen existing health conditions.
- Do not use the 3D Glasses for other purposes (such as general eyeglasses, sunglasses, or protective goggles).
- Do not use the 3D function or 3D Glasses while walking or moving around. This may result in injuries due to running into objects, tripping, and/or falling.
- When using the 3D Glasses, take care not to accidentally strike the screen or other people. Viewing 3D images may cause you to misjudge the distance to the screen and accidentally strike the screen, resulting in possible injury.

Precautions on viewing 3D images

- When viewing 3D images continuously, be sure to take a break periodically to prevent eye strain.
- Take regular breaks, at least 5 to 15 minutes after every 30 to 60 minutes of 3D viewing.
* Based on the guidelines issued by the 3D Consortium revised December 10, 2008.
- View 3D images at the appropriate distance from the screen. The recommended distance is three times the effective height of the picture.
Examples of recommended distances
100-inch 16:9 picture: Approx. 12.3 ft (3.8 m)
Viewing should not be done closer than the recommended distance.
Refer to page 18 for details on the diagonal size and height of the picture.
- Maintain an appropriate distance from the screen. Viewing from too close a distance can strain your eyes. If you experience eye strain, immediately discontinue viewing.
If you experience any of the following symptoms during viewing:
 - nausea
 - queasiness/dizziness
 - headache
 - blurry vision or double vision that lasts longer than few secondsDo not engage in any potentially hazardous activity (for example, driving a vehicle) until your symptoms have completely gone away.
If symptoms persist, discontinue use and do not resume 3D viewing without discussing your symptoms with a physician.

- Be careful of your surroundings when viewing 3D images. When you view 3D images, objects may appear at a distance closer or farther than the actual screen. This may cause you to misjudge the distance to the screen and possibly result in injury if you accidentally hit the screen or surrounding objects.

As you get more comfortable viewing 3D images:

- Operate the “3D Depth Adjust” function to adjust the 3D effect. (See page 55.)
- Adjust the projected image to the most comfortable viewing size by zooming. (Projecting images on the smallest or largest screen size possible may eliminate the 3D effect and strain your eyes.)
- Use the Invert function to properly set the video for your left and right eyes. (For details on using “Invert”, see page 55.)
- A picture simultaneously projected from more than two projectors may not appear 3D.

Info

- The projected image may become dark when using the 3D projection function (with “3D” set to “On”).
- When “3D” is set to “On”, the following functions may not work fully or may not be available at all.
 - Keystone/Sphere/Rotation
 - Image Shift
 - Magnify
- If the power of your left and right eyes greatly differs and you primarily use one eye for viewing the images, the images will not appear in 3D. In addition, images may be difficult to view in 3D or images may not be able to be viewed in 3D depending on the individual or the content being displayed. The 3D effect varies with the individual.

Warning!

- The following people should limit 3D viewing:
 - Children under 5 years of age (to protect the eye growth process)
 - People with a history of photosensitivity
 - People with heart disease
 - People in poor health
 - People who are sleep deprived
 - People who are physically tired
 - People under the influence of drugs or alcohol

■ Epilepsy

A small percentage of the population may experience epileptic or strokes seizures or strokes when viewing certain types of images that contain flashing patterns of light.

IF YOU OR ANY MEMBER OF YOUR FAMILY HAS A HISTORY OF EPILEPSY

The following people should consult a physician before viewing 3D images.

- Anyone with a history of epilepsy, or who has a family member with a history of epilepsy
- Children under 5 years of age
- Anyone who has ever experienced epileptic seizures or sensory disturbances triggered by flashing light effects

SOME LIGHT PATTERNS MAY INDUCE SEIZURES IN PERSONS WITH NO PRIOR HISTORY OF EPILEPSY

Discontinue use if you experience any of the following symptoms while viewing 3D images.

- Involuntary movements, eye or muscle twitching
- Muscle cramps
- Nausea, dizziness, or queasiness
- Convulsions
- Disorientation, confusion, or loss of awareness of your surroundings

Enjoying 3D Image Viewing (Continued)

Supplied Accessories for 3D Glasses

Make sure the following accessories are provided with the 3D Glasses. Two sets of 3D Glasses are provided.

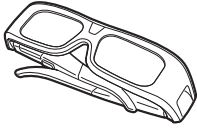

3D Glasses
(x2)
Pages 51 to 54



3D Glasses band *
(x2)
Page 52



Nose pad *
(Large x2, small x2)
Page 52



Glasses case
(x2)

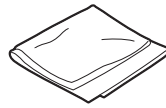

Cleaning cloth
(x2)

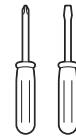

Precision screwdriver
(Phillips x2, slotted x2)
Page 51

* Use the 3D Glasses band and nose pad as needed.

Note

- Please contact your local authority for the correct method of disposal of this product and/or packaging.

Part Names

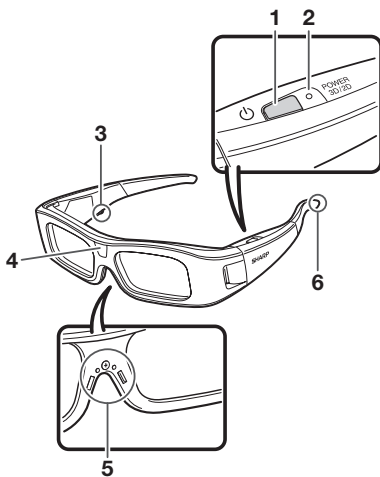

1 Power button

- Press for at least 2 seconds to turn on and off the 3D Glasses.
- When the 3D Glasses are turned on, pressing this button switches between 2D and 3D modes. (See page 52.)

2 LED light

- Blinks 3 times when the power is turned on.
- Blinks 2 times when 2D mode is selected.
- Blinks 3 times when 3D mode is selected.
- Blinks 6 times when the battery power is low.
- Lights for 2 seconds when the power is turned off.

3 Service terminal

This terminal is for service use only.
Please do not connect any other device to this terminal.

4 Infrared receiver

An infrared signal sent from the projector is reflected onto the screen. The reflected infrared signal is then received by the infrared receiver. The 3D Glasses turn off automatically after 3 minutes if no signal is received.

5 Nose pad mount **52**

The dedicated nose pad can be mounted here.

6 3D Glasses band mount **52**

The dedicated 3D Glasses band can be mounted here.

Note

- Do not soil or apply stickers or other obstacles to the infrared receiver. Doing so may block signals from the screen and prevent the 3D Glasses from working correctly.
- Interference from other infrared communications equipment may prevent you from viewing 3D images correctly.

Before Using the 3D Glasses

Before using the 3D Glasses for the first time, remove the insulating sheet attached to them.

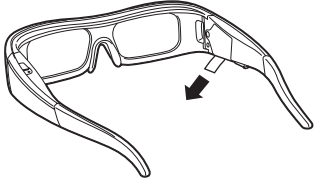

Replacing the Button Cell Battery

The battery has an expected service life of approximately 75 hours.

- When the battery power is low, the LED light blinks six times after the power is turned on.
- When replacing the button cell, use only the designated battery type (Maxell branded CR2032 lithium button battery).

- 1 Loosen the screw used to secure the battery cover, and then remove the battery cover.**

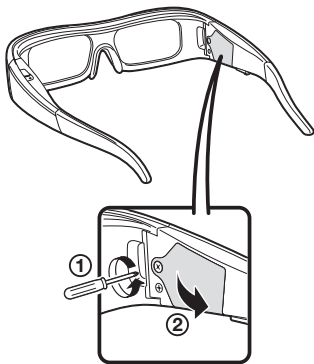

- 2 Remove the button cell battery.**

- ① Place the tip of the slotted precision screwdriver into the opening between the button cell and the socket.
- ② Lift up the button cell while taking care not to get the screwdriver caught on the metal latch.

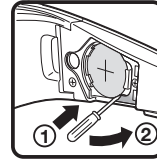

- 3 When the battery comes loose from the socket, pick it out with your fingers.**

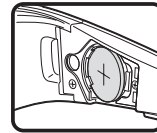

- 4 Hook a new button cell to the metal latch and insert it into the socket.**

- Take care not to reverse the battery polarity (+ and -) when inserting the button cell.

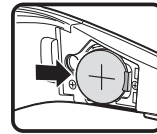

- 5 Close the battery cover.**

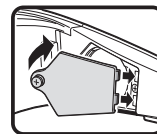

- 6 Insert the screw to secure the battery cover.**

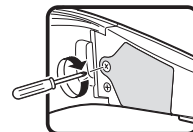

Note

- Used batteries should be disposed in accordance with local laws and regulations.

Enjoying 3D Image Viewing (Continued)

Attaching the Nose Pad

Attach either of the supplied nose pads as needed (such as when the glasses do not fit properly). The glasses come with a large and small nose pad.

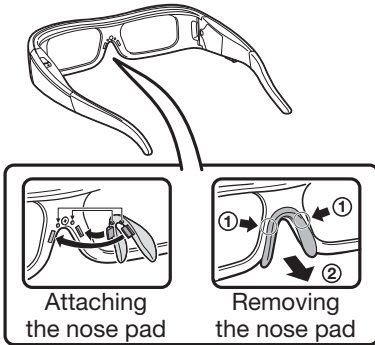

Note

- When the battery power is low, the LED light blinks 6 times after the power is turned on.

Switching to 3D and 2D Mode

When viewing 3D images, you can press the power button to switch between 2D and 3D modes. This is useful when several people are viewing the same 3D images with some people wanting to watch in 3D and some people wanting to watch in 2D.

Viewing 2D images

When you press the power button twice while viewing 3D images, the LED light blinks 2 times and the 3D images switch to 2D images.

Viewing 3D images

When you press the power button twice while viewing 2D images, the LED light blinks 3 times and the 2D images switch to 3D images.

Attaching the 3D Glasses Band

Attach the supplied 3D Glasses band strap as needed (such as when the glasses do not fit properly).

Insert the ends of the 3D Glasses into the 3D Glasses band until they are secure.

- Pull the cord stopper on the strap to adjust the strap length.

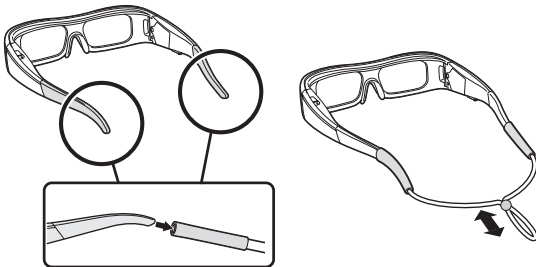

Using the 3D Glasses

Turning On/Off the Power

Turn on the power of the 3D Glasses.

- Press the power button for at least 2 seconds.
- The LED light blinks 3 times.

Turn off the power on the 3D Glasses.

- Press the power button for at least 2 seconds.
- The LED light lights for 2 seconds.

Usage Range of the 3D Glasses

An infrared signal sent from the projector is reflected onto the screen. The 3D Glasses operate by receiving the reflected infrared signal.

The 3D Glasses turn off automatically after 3 minutes if no signal is received.

The operating range of the 3D Glasses is shown in the table below.

"IR Emitter Level" setting	Operating range (distance from the screen)
Normal	Approx. 12.3 ft (3.8 m)
High	Approx. 18.3 ft (5.6 m)

(For details of the "IR Emitter Level", see page 55.)

- Be sure to stay within the operating range when watching 3D images. Otherwise, the 3D Glasses may not work properly and you may not be able to enjoy the 3D images.
- The operating range in the table above is the average value when using a screen with a screen gain of 1.0 and when viewing in front of the screen. The operating range may vary depending on your view position and/or the usage condition (e.g., Gain level of screen). (The operating range decreases when you view the screen at an angle.)



Note

- The IR (infrared) emitter lights in 3D mode.

3D MENU button

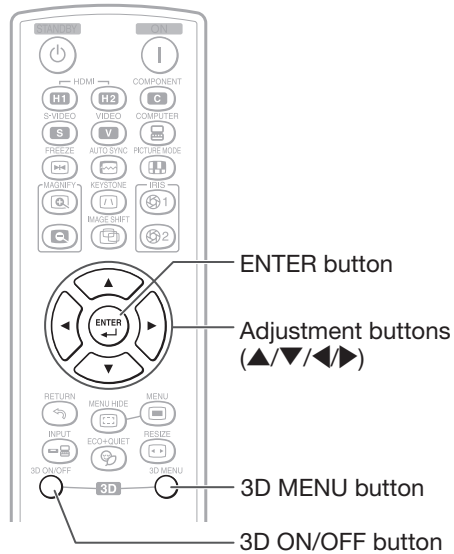
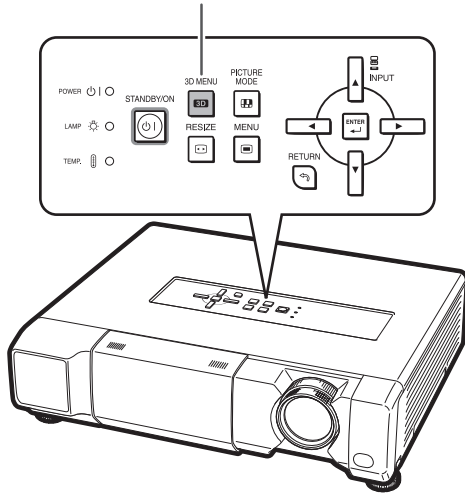

Note

- The screen may temporarily become black when the projector is trying to detect a 3D image signal and when switching from 3D to 2D mode.

Viewing 3D Images

Receiving a 3D Image Signal That Can Be Detected Automatically

The image signal may contain a 3D identification signal. You can enable the projector to automatically detect the 3D image type by selecting “3D MENU” > “3D Auto Change”. (See page 55.)

- 1 When “3D Auto Change” is set to “Yes”**
 - The 3D image type is detected automatically and the appropriate 3D image is displayed.

When “3D Auto Change” is set to “No”

- The following message is displayed. Press **3D ON/OFF**.

3D picture is detected.
Press the 3D ON/OFF button on the remote control.
(Need to wear the 3D glasses to watch 3D picture)

- 2 Turn on the 3D Glasses and place them over your eyes.**
 - Press the power button for at least 2 seconds.
 - The LED light blinks 3 times.
- 3 You can now view 3D images.**

Enjoying 3D Image Viewing (Continued)

Receiving a 3D Image Signal That Cannot Be Detected Automatically

- 1 Press 3D MENU.**
 - The 3D MENU screen is displayed.
- 2 Press ▲/▼ to select “3D”.**
- 3 Press ◀/▶ to select “On” or “Off”.**
 - To view in 3D mode: Select “On”, and then go to step 4.
 - Refer to “Setting the 3D Format Menu” on page 56 for supported 3D signals and formats.
 - If you select “Off”, the video source will be displayed with no conversion.
- 4 Press ▲/▼ to select “3D Format”, and then press ENTER.**
- 5 Press ▲/▼ to select a supported format from the list, and then press ENTER.**

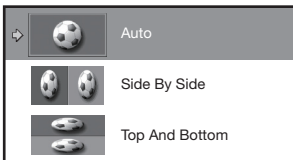

- If you select the same system as that of the input signal, 3D images are displayed.

- 6 Turn on the 3D Glasses and place them over your eyes.**
 - Press the power button for at least 2 seconds.
 - The LED light blinks 3 times.
- 7 You can now view 3D images.**

Ending 3D Image Viewing

- 1 Press 3D ON/OFF during the 3D mode.**
- 2 Take off the 3D Glasses and turn off the power.**
 - Press the power button for at least 2 seconds.
 - The LED light lights for 2 seconds.

Note

- If the input signal switches to 2D, 2D images are displayed automatically.
- 3D mode is canceled automatically in the following cases:
 - When the signal is no longer received
 - When the signal type changes
 - When input selection is changed
 - When the power is turned off

3D Settings (“3D MENU”)

The illustration shown here is for explanation and may be different from the actual on-screen display.

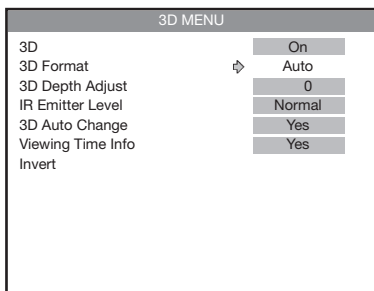

3D

You can switch between 2D and 3D mode.

Selectable items	Description
On	Projects 3D images.
Off	Projects 2D images instead of 3D images.

Note

- When “3D Auto Change” is set to “Yes” and a 3D signal is detected, “3D” switches to “On”.
- When a 3D identification signal is not detected:
 - If you selected “On”, select the format with “3D Format”.
 - If you select “Off”, the video source will be displayed with no conversion.

3D Format

You can set the 3D format manually for when a 3D signal that cannot be detected automatically is received.

Selectable items	Description
Auto	When a 3D identification signal is detected, the format is selected automatically.
Side By Side	Select the same format type of the received 3D signal.
Top And Bottom	

Note

- Refer to “Setting the 3D Format Menu” on page 56 for supported signals and 3D formats.

3D Depth Adjust

You can adjust the stereoscopic effect of 3D image.

Selectable items	Description
◀ button	For less stereoscopic effect.
▶ button	For greater stereoscopic effect.

Note

- Use this function to get more comfortable 3D images.
- When you use this function, the 3D image will look different from its original 3D appearance. Keep this in mind while using this function.
- The use of this function for commercial purposes/public displays in a café, hotel, etc., may be an infringement of copyright protected by law for copyright holders. Please use caution.

IR Emitter Level

You can change the infrared emitter level.

Selectable items	Description
Normal	Normal infrared emitter level
High	Select “High” when it is difficult for 3D Glasses to properly receive the infrared signal reflected off the screen due to the use of a large screen and viewers being positioned away from the screen.

Note

- When “High” is set, other nearby devices that receive infrared signals, such as remote control units of audio-video equipment and air conditioners, may not operate properly.

3D Auto Change

This setting can be used to switch to 3D mode automatically when a 3D identification signal is detected.

Selectable items	Description
Yes	When a 3D signal is detected, 3D mode is selected automatically.
No	Auto change is not performed.

Viewing Time Info

This displays the elapsed time of 3D image viewing.

Selectable items	Description
Yes	Displays the elapsed viewing time on the screen every hour.
No	Does not display the elapsed viewing time.

















Invert

Pressing **ENTER** switches between the image for the left eye and the image for the right eye, so that you can make the settings for more natural viewing.

Enjoying 3D Image Viewing (Continued)

Setting the 3D Format Menu

Select the appropriate 3D format for viewing while referring to the table below.

Input signal				Support	When "3D" is OFF	When "3D" is ON		
						3D Format		
					Auto	Side By Side	Top And Bottom	
Frame Packing 	with 3D identification signal	720P	50Hz	✓	Displays image for left eye (2D mode) 	Displays correct 3D image (3D mode) 	-*1	-*1
		720P	60Hz	✓				
		1080I	50Hz					
		1080I	60Hz					
		1080P	24Hz	✓				
		1080P	50Hz					
		1080P	60Hz					
Side By Side 	with 3D identification signal	720P	50Hz	✓	Displays image for left eye (2D mode) 	Displays correct 3D image (3D mode) 	-*1	-*1
		720P	60Hz	✓				
		1080I	50Hz	✓				
		1080I	60Hz	✓				
		1080P	24Hz					
		1080P	50Hz	✓				
	without 3D identification signal	720P	50Hz	✓	Displays raw input signal 	Displays raw input signal 	Displays correct 3D image (3D mode) 	Garbled display (Incorrect setting) 
		720P	60Hz	✓				
		1080I	50Hz	✓				
		1080I	60Hz	✓				
		1080P	24Hz					
		1080P	50Hz	✓				
		1080P	60Hz	✓				
Top And Bottom 	with 3D identification signal	720P	50Hz	✓	Displays image for left eye (2D mode) 	Displays correct 3D image (3D mode) 	-*1	-*1
		720P	60Hz	✓				
		1080I	50Hz					
		1080I	60Hz					
		1080P	24Hz	✓				
		1080P	50Hz	✓				
		1080P	60Hz	✓				
	without 3D identification signal	720P	50Hz	✓	Displays raw input signal 	Displays raw input signal 	Garbled display (Incorrect setting) 	Displays correct 3D image (3D mode) 
		720P	60Hz	✓				
		1080I	50Hz					
		1080I	60Hz					
		1080P	24Hz	✓				
		1080P	50Hz	✓				
		1080P	60Hz	✓				

*1 "3D Format" is set to "Auto" automatically.

*2 The frame rate is changed.



Note

- These 3D Glasses can only be used with Sharp 3D-compatible LCD TVs or projectors that use infrared control technology.

3D Glasses lenses

- Do not apply pressure to the lenses of the 3D Glasses. Also, do not drop or bend the 3D Glasses.
- Do not scratch the surface of the lenses of the 3D Glasses with a pointed instrument or other object. Doing so may damage the 3D Glasses and reduce the quality of the 3D image.
- Use only the cloth provided with the 3D Glasses to clean the lenses.

3D Glasses infrared receiver

- Do not allow the infrared receiver to become dirty, and do not attach stickers to or otherwise cover the infrared receiver. Doing so may prevent the receiver from operating normally.
- If the 3D Glasses are affected by other infrared data communication equipment, the 3D images may not be displayed correctly.

Caution during viewing

- Do not use devices that emit strong electromagnetic waves (such as cellular phones or wireless transceivers) near the 3D Glasses. Doing so may cause the 3D Glasses to malfunction.
- The 3D Glasses cannot operate fully at extreme high or low temperatures. Please use them within the specified usage temperature range.
- If the 3D Glasses are used in a room with fluorescent lighting (60 Hz), the light within the room may appear to flicker. In this case, either darken or turn off the fluorescent lights when using the 3D Glasses.
- Wear the 3D Glasses correctly. 3D images will not be correctly visible if the 3D Glasses are worn upside down or back-to-front.
- Other displays (such as computer screens, digital clocks, and calculators) may appear dark and difficult to view while wearing the 3D Glasses. Do not wear the 3D Glasses when watching anything other than 3D images.
- If you lie on your side while watching the screen with 3D Glasses, the picture may look dark or may not be visible.
- Be sure to stay within the viewing angle and optimum viewing distance when watching 3D images. Otherwise, you may not be able to enjoy the full 3D effect.
- The 3D Glasses may not work properly if there is any other 3D product or electronic devices turned on near the glasses or projector. If this occurs, turn off the other 3D product or electronic devices or keep the devices as far away as possible from the 3D Glasses.
- Stop using this product in any of the following situations:
 - When images consistently appear doubled while you are wearing the 3D Glasses
 - When you have difficulty perceiving the 3D effect
- If the 3D Glasses are faulty or damaged, stop using them immediately. Continued use of the 3D Glasses may cause eye fatigue, headaches and illness.
- If you have any abnormal skin reaction, stop using the 3D Glasses. In very rare instances, such reactions may be due to an allergic reaction to the coating or materials used.
- If your nose or temples become red or you experience any pain or itchiness, stop using the 3D Glasses. Pressure caused by long periods of use may lead to such reactions and may result in skin irritation.

Enjoying 3D Image Viewing (Continued)

Specifications – 3D Glasses

Model	AN-3DG10
Lens type	Liquid crystal shutter
Power supply	3 V DC
Battery	Lithium button battery (CR2032 × 1)
Battery life	Approx. 75 hours of continuous use
Dimension (W x H x D)	6 ¹³ / ₁₆ × 1 ⁷ / ₈ × 6 ⁴⁵ / ₆₄ inch (172.7 × 47.5 × 170.0 mm)
Weight	0.2 lbs./65.0 g (including the lithium button battery)
Operating temperature	50°F to 104°F (10°C to 40°C) (The 3D Glasses cannot operate fully at extreme high or low temperatures. Please use them within the specified usage temperature range.)

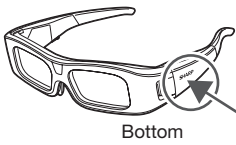

The product serial number is displayed on the 3D Glasses as indicated in the illustration on the left. The first four digits represent the product color and the date of manufacture.

Example: Silver colored glasses manufactured on August 11, 2010

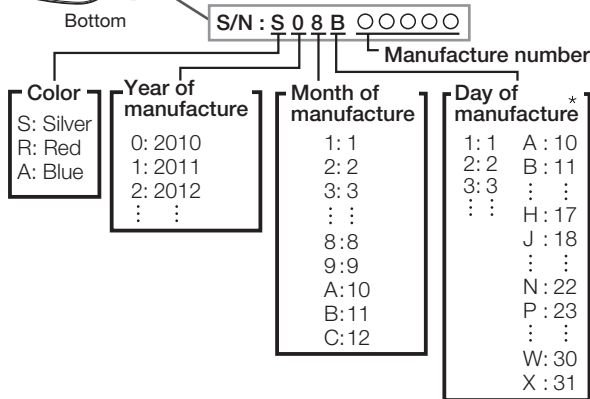

*"I", "O", "Y", and "Z" are not used.

These symbols displayed on the product and the individual carton package of the product are symbols about the environment in Japan, China and the EU.



For Japan only:



For China only:



For China only:



EU only

For the EU only:

Maintenance

Cleaning the projector

- Ensure that you have unplugged the power cord before cleaning the projector.
- The cabinet as well as the operation panel is made of plastic. Avoid using benzene or thinner, as these can damage the finish on the cabinet.
- Do not use volatile agents such as insecticides on the projector.
Do not attach rubber or plastic items to the projector for long periods.
The effects of some of the agents in the plastic may cause damage to the quality or finish of the projector.
- Wipe off dirt gently with a soft flannel cloth. Using a chemical cloth (wet/dry sheet type cloth, etc.) may deform the components of the cabinet or cause cracking.
- Wiping with a hard cloth or using strong force may scratch the cabinet surface.
- When the dirt is hard to remove, soak a cloth in a mild detergent diluted with water, wring the cloth well and then wipe the projector. Strong cleaning detergents may discolor, warp or damage the coating on the projector. Make sure to test on a small, inconspicuous area on the projector before use.

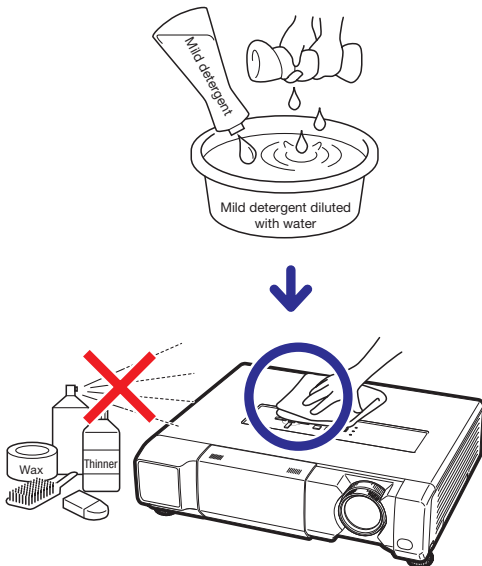

Cleaning the lens

- Use a commercially available blower or lens cleaning paper (for glasses and camera lenses) for cleaning the lens. Do not use any liquid type cleaning agents, as they may wear off the coating film on the surface of the lens.
- As the surface of the lens can easily get damaged, be careful not to scrape or hit the lens.

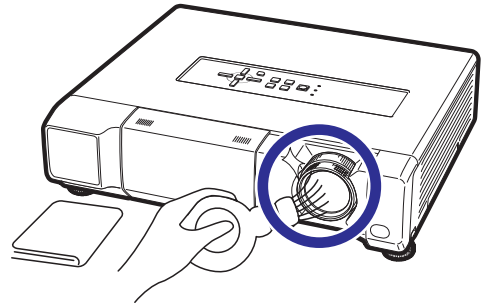

Cleaning the exhaust and intake vents

- Use a vacuum cleaner to clean dust from the exhaust vent and the intake vent.

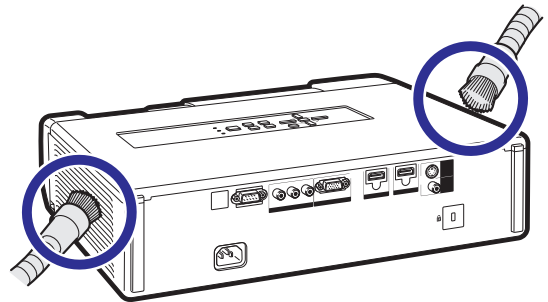

Info

- If you want to clean the air vents during projector operation, ensure you press **STANDBY/ON** on the projector or **STANDBY** on the remote control and put the projector into standby mode. After the cooling fan has stopped, clean the vents.

Maintenance Indicators

- The warning lights (power indicator, lamp indicator and temperature warning indicator) on the projector indicate problems inside the projector.
- If a problem occurs, either the temperature warning indicator or the lamp indicator will illuminate red, and the projector will enter standby mode. After the projector has entered standby mode, follow the procedures given below.

Top View

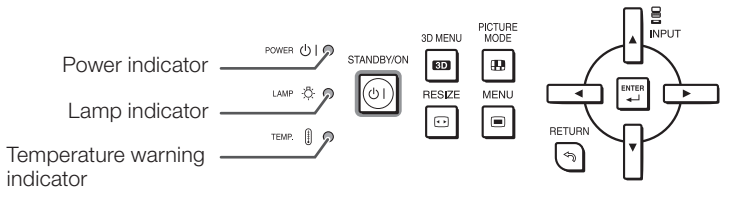

About the temperature warning indicator



If the temperature inside the projector increases, due to blockage of the air vents, or the setting location, the temperature warning indicator will blink. And if the temperature keeps on rising, “TEMP.” will illuminate in the lower left corner of the picture with the temperature warning indicator blinking. If this state continues, the lamp will turn off, the cooling fan will run and then the projector will enter standby mode. When you find the temperature warning indicator blinking, be sure to perform the measures described on page 61.

About the lamp indicator



- When the remaining lamp life becomes 5% or less, (yellow) and “Change The Lamp” will be displayed on the screen. When the percentage becomes 0%, it will change to (red), the lamp will automatically turn off and then the projector will automatically enter standby mode. At this time, the lamp indicator will illuminate in red.
- **If you try to turn on the projector a fourth time without replacing the lamp, the projector will not turn on.**

Indicators on the Projector

Power indicator	Red on	Normal (Standby)
	Green on	Normal (Power on)
	Red blinks	Abnormal (See page 61.)
	Green blinks	Normal (Cooling)
	Green and orange blink alternately	The lens shutter is closed. (See page 23.)
Lamp indicator	Green on	Normal
	Green blinks	The lamp is warming up.
	Red on	The lamp is shut down abnormally or requires to be changed. (See page 61.)
Temperature warning indicator	Off	Normal
	Red on/Red blinks	The internal temperature is abnormally high. (See page 61.)

	Maintenance indicator		Problem	Cause	Possible Solution
	Normal	Abnormal			
Temperature warning indicator	Off	Red blinks (On)/ Red on (Standby)	The internal temperature is abnormally high.	<ul style="list-style-type: none"> • Temperatures around the projector are high. • Blocked air intake 	<ul style="list-style-type: none"> • Use the projector in an area with a temperature of lower than 95°F (+35°C). • Relocate the projector to an area with proper ventilation. (See page 7.)
				<ul style="list-style-type: none"> • Cooling fan breakdown • Internal circuit failure • Clogged air intake 	<ul style="list-style-type: none"> • Take the projector to your nearest Sharp Authorized Projector Dealer or Service Center (see page 75) for repair.
Lamp indicator	Green on (Green blinks when the lamp is warming up.)	Red on (Standby)	The lamp does not illuminate.	<ul style="list-style-type: none"> • The lamp is shut down abnormally. 	<ul style="list-style-type: none"> • Disconnect the power cord from the AC outlet, and then connect it again.
			Time to change the lamp.	<ul style="list-style-type: none"> • Remaining lamp life becomes 5% or less. 	<ul style="list-style-type: none"> • Carefully replace the lamp. (See page 62.) • Take the projector to your nearest Sharp Authorized Projector Dealer or Service Center (see page 75) for repair. • Please exercise care when replacing the lamp. • Securely install the cover.
			The lamp does not illuminate.	<ul style="list-style-type: none"> • Burnt-out lamp • Lamp circuit failure 	
Power indicator	Green on/ Red on Green blinks (Cooling)	Red blinks	The power indicator blinks in red when the projector is on.	<ul style="list-style-type: none"> • The lamp unit cover is open. 	<ul style="list-style-type: none"> • If the power indicator blinks in red even when the lamp unit cover are securely installed, contact your nearest Sharp Authorized Projector Dealer or Service Center (see page 75) for advice.

Info

- If the temperature warning indicator illuminates, and the projector enters standby mode, follow the possible solutions above and then wait until the projector has cooled down completely before plugging in the power cord and turning the power back on. (At least 10 minutes.)
- If the power is turned off for a brief moment due to power outage or some other cause while using the projector, and the power supply recovers immediately after that, the lamp indicator will illuminate in red and the lamp may not be lit. In this case, unplug the power cord from the AC outlet, replace the power cord in the AC outlet and then turn the power on again.
- The cooling fan keeps the internal temperature of the projector constant and this function is controlled automatically. The sound of the cooling fan may change during operation because the fan speed may change and this is not a malfunction.

Regarding the Lamp

Lamp

- It is recommended that the lamp (sold separately) be replaced when the remaining lamp life becomes 5% or less, or when you notice a significant deterioration in the picture and color quality. The lamp life (percentage) can be checked with the on-screen display. (See page 47.)
- Purchase a replacement lamp of type AN-K15LP from your place of purchase, nearest Sharp Authorized Projector Dealer or Service Center.

IMPORTANT NOTE TO U.S. CUSTOMERS:

The lamp included with this projector is backed by a 90-day parts and labor limited warranty. All service of this projector under warranty, including lamp replacement, must be obtained through a Sharp Authorized Projector Dealer or Service Center. For the name of the nearest Sharp Authorized Projector Dealer or Service Center, please call toll-free: 1-888-GO-SHARP (1-888-467-4277).

Hg LAMP CONTAINS MERCURY For State Lamp Disposal Information
www.lamprecycle.org or 1-800-BE-SHARP

U.S.A. ONLY

Caution Concerning the Lamp

- This projector utilizes a pressurized mercury lamp. A loud sound may indicate lamp failure. Lamp failure can be attributed to numerous sources such as: excessive shock, improper cooling, surface scratches or deterioration of the lamp due to a lapse of usage time.
The period of time up to failure largely varies depending on the individual lamp and/or the condition and the frequency of use. It is important to note that failure can often result in the bulb cracking.
- When the lamp replacement indicator and on-screen display icon are illuminated, it is recommended that the lamp be replaced with a new one immediately, even if the lamp appears to be operating normally.
- Should the lamp break, there is also a possibility that glass particles may spread inside of the projector. In such a case, it is recommended you contact your nearest Sharp Authorized Projector Dealer or Service Center to assure safe operation.
- Should the lamp break, the glass particles may spread inside the lamp cage or gas contained in the lamp may be vented into the room from the exhaust vent. Because the gas in this lamp includes mercury, ventilate the room well if the lamp breaks and avoid all exposure to the released gas. In case of exposure to the gas, consult a doctor as soon as possible.

Replacing the Lamp



Caution

- Do not remove the lamp unit from the projector right after use. The lamp will be very hot and may cause burns or injury.
- Wait at least one hour after the power cord is disconnected to allow the surface of the lamp unit to fully cool before removing the lamp unit.

- **Carefully change the lamp by following the instructions described in this section. * If you wish, you may have the lamp replaced at your nearest Sharp Authorized Projector Dealer or Service Center.**

* If the new lamp does not light after replacement, take your projector to the nearest Sharp Authorized Projector Dealer or Service Center for repair.

Removing and Installing the Lamp Unit

- Warning!** • Do not remove the lamp unit from the projector right after use. The lamp and parts around the lamp will be very hot and may cause burns or injury.

Info

- Do not touch the glass surface of the lamp unit or the inside of the projector.
- To avoid injury to yourself and damage to the lamp, make sure you carefully follow the steps below.
- Do not loosen other screws except for the lamp unit cover and lamp unit.

Optional
accessory

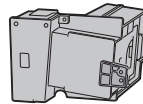

Lamp unit
AN-K15LP

- 1** Press **STANDBY/ON** on the projector or **STANDBY** on the remote control to put the projector into standby mode.

- 2** **Disconnect the power cord.**
- Unplug the power cord from the AC socket.
 - Leave the lamp until it has fully cooled down (about 1 hour).

- 3** **Remove the lamp unit cover.**
- Close the lens shutter. Loosen the user service screw (①) that secures the lamp unit cover. Remove the lamp unit cover (②).

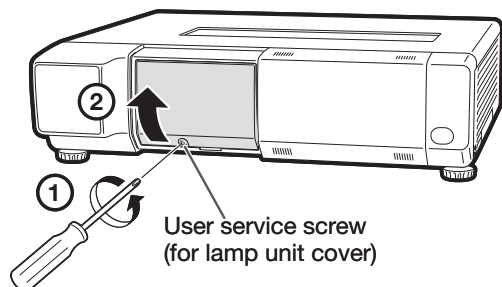
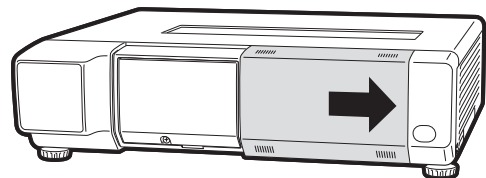
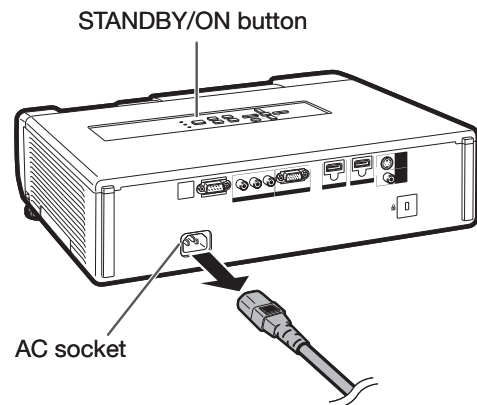

Regarding the Lamp (Continued)

4 Remove the lamp unit.

- Loosen the securing screws from the lamp unit. Hold the lamp unit and pull it in the direction of the arrow. At this time, keep the lamp unit horizontal and do not tilt it.

5 Insert the new lamp unit.

- Press the lamp unit firmly into the lamp unit compartment. Fasten the securing screws.

6 Replace the lamp unit cover.

- Align the tab on the lamp unit cover (1) and place it while pressing the cover (2) to close it. Then tighten the user service screw (3) to secure the lamp unit cover.

Info

- If the lamp unit and lamp unit cover are not correctly installed, the power will not turn on, even if the power cord is connected to the projector.

Securing screws

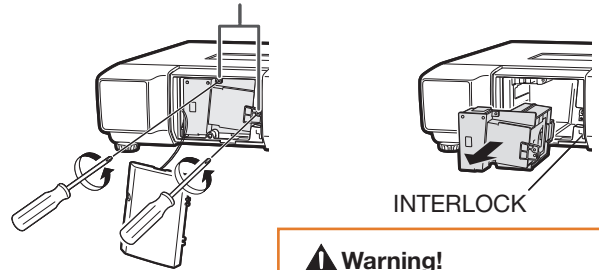

Warning!
DO NOT DEFEAT THIS INTERLOCK

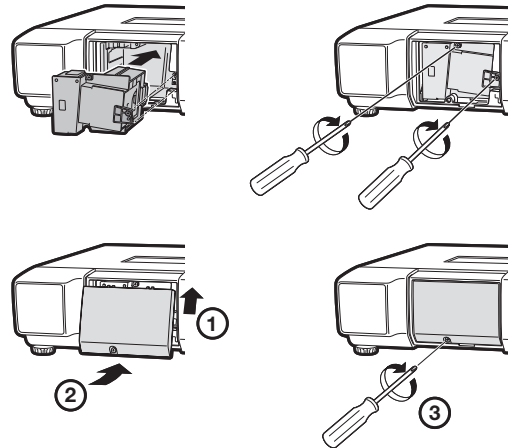

Resetting the Lamp Timer

Reset the lamp timer after replacing the lamp.

Info

- Make sure to reset the lamp timer only when replacing the lamp. If you reset the lamp timer and continue to use the same lamp, this may cause the lamp to become damaged or explode.

1 Connect the power cord and open the lens shutter fully.

- Plug the power cord into the AC socket of the projector.

2 Reset the lamp timer.

- While simultaneously holding down **MENU**, **ENTER** and **▼** on the projector, press **STANDBY/ON** on the projector and keep all four buttons pressed down until the lamp indicator starts blinking green.
- "LAMP 0000 H" is displayed, indicating that the lamp timer is reset.

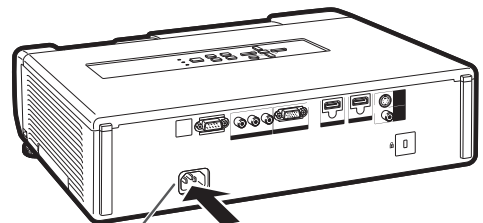

AC socket

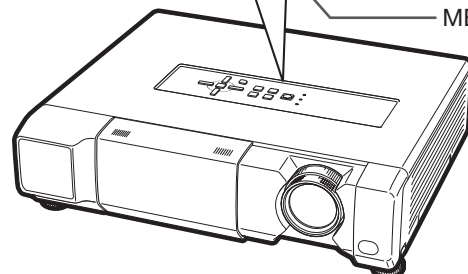
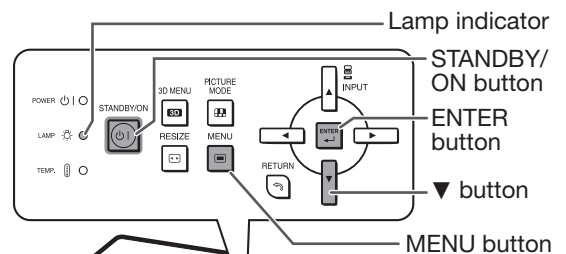

Connecting Pin Assignments

COMPUTER/COMPONENT input Terminal : mini D-sub 15 pin female connector

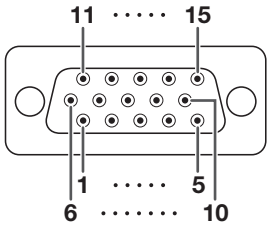

COMPUTER Input

Pin No.	Signal
1	Video input (red)
2	Video input (green/sync on green)
3	Video input (blue)
4	Not connected
5	Not connected
6	Earth (red)
7	Earth (green/sync on green)
8	Earth (blue)
9	Not connected
10	GND
11	Not connected
12	Bi-directional data
13	Horizontal sync signal: TTL level
14	Vertical sync signal: TTL level
15	Data clock

COMPONENT Input

Pin No.	Signal
1	PR (CR)
2	Y
3	PB (CB)
4	Not connected
5	Not connected
6	Earth (PR)
7	Earth (Y)
8	Earth (PB)
9	Not connected
10	Not connected
11	Not connected
12	Not connected
13	Not connected
14	Not connected
15	Not connected

RS-232C Terminal: 9-pin D-sub male connector

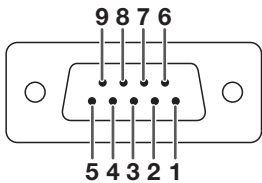

Pin No.	Signal	Name	I/O	Reference
1				Not connected
2	RD	Receive Data	Input	Connected to internal circuit
3	SD	Send Data	Output	Connected to internal circuit
4		Reserved		Connected to internal circuit
5	SG	Signal Ground		Connected to internal circuit
6		Reserved		Connected to internal circuit
7		Reserved		Connected to internal circuit
8		Reserved		Connected to internal circuit
9				Not connected

HDMI Terminal

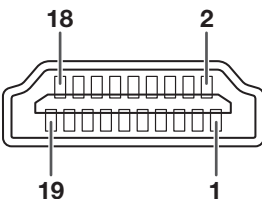

Pin No.	Name	Pin No.	Name	Pin No.	Name
1	T.M.D.S data 2+	8	T.M.D.S data 0 shield	14	Utility
2	T.M.D.S data 2 shield	9	T.M.D.S data 0-	15	SCL
3	T.M.D.S data 2-	10	T.M.D.S clock+	16	SDA
4	T.M.D.S data 1+	11	T.M.D.S clock shield	17	DDC/CEC ground
5	T.M.D.S data 1 shield	12	T.M.D.S clock-	18	+5V power
6	T.M.D.S data 1-	13	CEC	19	Hot plug detection
7	T.M.D.S data 0+				



RS-232C Specifications and Commands

Computer control

A computer can be used to control the projector by connecting an RS-232C cable (null modem, cross type, commercially available) to the projector. (See page 22 for connection.)

Communication conditions

Set the serial port settings of the computer as follows.

Signal format: Conforms to RS-232C standard.

Baud rate*: 9,600 bps / 38,400bps / 115,200bps

Data length: 8 bits

*Use the same settings for the projector and computer.

Parity bit: None

Stop bit: 1 bit

Flow control: None

Basic format

Send commands from the computer in the following order: command, parameter, and return code. After processing the command from the computer, the projector sends a response code to the computer.

Command format

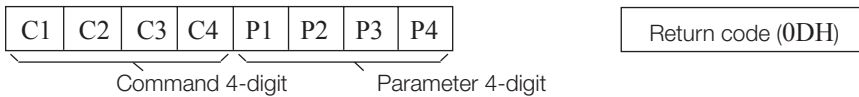

Response code format

Normal response

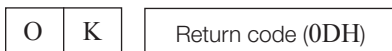

Problem response (communication error or incorrect command)



Info

- When controlling the projector using RS-232C commands from a computer, wait for at least 30 seconds after the power has been turned on, and then transmit the commands.
- After sending an input selection or picture adjustment command and then receiving an “OK” response code, the projector may take some time to process the command. If a second command is sent while the projector is still processing the first command, you may receive an “ERR” response code. If this happens, try resending the second command.
- When more than one code is being sent, send each command only after the response code for the previous command from the projector is verified.
- “POWR????”, “TABN ___ 1”, “TLPS ___ 1”, “TPOW ___ 1”, “TLPN ___ 1”, “TLTT ___ 1”, “TLTM ___ 1”, “TLTL ___ 1”, “TNAM ___ 1”, “MNRD ___ 1”, “PJNO ___ 1”
 - When the projector receives the special commands shown above:
 - * The on-screen display will not disappear.
 - * The “Auto Power Off” timer will not be reset.
 - The special commands are available for applications that require continuous polling.

Commands

Example: To turn on the projector

Computer

P	O	W	R	_	_	_	1	↵
---	---	---	---	---	---	---	---	---



Projector

O	K	↵
---	---	---

Control Contents		Command				Parameter				Return		
										Power ON	Standby mode (or 30-second startup time)	
Power	On	P	O	W	R	-	-	-	1	OK or ERR	OK	
	Off	P	O	W	R	-	-	-	0	OK	OK or ERR	
	Status	T	L	P	S	?	?	?	?	1	0	
Projector Condition		T	A	B	N	-	-	-	1	0:Normal 1:Temp High 8:Lamp Life 5% or less 16:Lamp Burnt-out 32:Lamp Ignition Failure	0:Normal 1:Temp High 2:Fan Error 4:Lamp Cover Open 8:Lamp Life 5% or less 16:Lamp Burnt-out 32:Lamp Ignition Failure 64:Temp Abnormally High	
Lamp	Status	T	L	P	S	-	-	-	1	0:Off, 1:On, 2:Retry 3:Waiting, 4:Lamp Error	0:Off, 4:Lamp Error	
	Power Status	T	P	O	W	-	-	-	1	1:On, 2:Cooling	0:Standby	
	Quantity	T	L	P	N	-	-	-	1	1		
	Usage Time (Hour)	T	L	T	T	-	-	-	1	0-9999 (Integer)		
	Usage Time (Minute)	T	L	T	M	-	-	-	1	0, 15, 30, 45		
Life (Percentage)	T	L	T	L	-	-	-	1	0%-100% (Integer)			
Name	Model Name Check	T	N	A	M	-	-	-	1	XVZ17000		
	Model Name Check	M	N	R	D	-	-	-	1	XV-Z17000		
	Projector Name Setting1 (First 4 characters) *1	P	J	N	1	*	*	*	*	OK or ERR		
	Projector Name Setting2 (Middle 4 characters) *1	P	J	N	2	*	*	*	*	OK or ERR		
	Projector Name Setting3 (Last 4 characters) *1	P	J	N	3	*	*	*	*	OK or ERR		
	Projector Name Check	P	J	N	0	-	-	-	1	Projector Name		
Input Change	COMPUTER	I	R	G	B	-	-	-	1	OK or ERR	ERR	
	COMPONENT	I	R	G	B	-	-	-	2	OK or ERR	ERR	
	HDMI1	I	R	G	B	-	-	-	3	OK or ERR	ERR	
	HDMI2	I	R	G	B	-	-	-	4	OK or ERR	ERR	
	S-VIDEO	I	V	E	D	-	-	-	1	OK or ERR	ERR	
	VIDEO	I	V	E	D	-	-	-	2	OK or ERR	ERR	
	Input RGB Check	I	R	G	B	?	?	?	?	1: COMPUTER, 2: COMPONENT, 3: HDMI1, 4: HDMI2, ERR	ERR	
	Input Video Check	I	V	E	D	?	?	?	?	1: S-VIDEO, 2: VIDEO, ERR	ERR	
	Input Mode Check	I	M	O	D	?	?	?	?	1: RGB, 2: VIDEO	ERR	
	Input Check	I	C	H	K	?	?	?	?	1: COMPUTER 2: COMPONENT 3: HDMI1 4: HDMI2 5: S-VIDEO 6: VIDEO	ERR	
Resize	COMPUTER	Normal	R	A	S	R	-	-	-	1	OK or ERR	ERR
		16:9	R	A	S	R	-	-	-	2	OK or ERR	ERR
		Native	R	A	S	R	-	-	-	3	OK or ERR	ERR
		Cinema Zoom	R	A	S	R	-	-	-	5	OK or ERR	ERR
		Zoom14:9	R	A	S	R	-	-	-	7	OK or ERR	ERR
		Smart Zoom	R	A	S	R	-	-	-	6	OK or ERR	ERR
	COMPONENT	Normal	R	B	S	R	-	-	-	1	OK or ERR	ERR
		16:9	R	B	S	R	-	-	-	2	OK or ERR	ERR
		Native	R	B	S	R	-	-	-	3	OK or ERR	ERR
		Cinema Zoom	R	B	S	R	-	-	-	5	OK or ERR	ERR
		Zoom14:9	R	B	S	R	-	-	-	7	OK or ERR	ERR
		Smart Zoom	R	B	S	R	-	-	-	6	OK or ERR	ERR
	HDMI1	Normal	R	C	S	R	-	-	-	1	OK or ERR	ERR
		16:9	R	C	S	R	-	-	-	2	OK or ERR	ERR
		Native	R	C	S	R	-	-	-	3	OK or ERR	ERR
		Cinema Zoom	R	C	S	R	-	-	-	5	OK or ERR	ERR
		Zoom14:9	R	C	S	R	-	-	-	7	OK or ERR	ERR
		Smart Zoom	R	C	S	R	-	-	-	6	OK or ERR	ERR
	HDMI2	Normal	R	D	S	R	-	-	-	1	OK or ERR	ERR
		16:9	R	D	S	R	-	-	-	2	OK or ERR	ERR
		Native	R	D	S	R	-	-	-	3	OK or ERR	ERR
		Cinema Zoom	R	D	S	R	-	-	-	5	OK or ERR	ERR
		Zoom14:9	R	D	S	R	-	-	-	7	OK or ERR	ERR
		Smart Zoom	R	D	S	R	-	-	-	6	OK or ERR	ERR
	S-VIDEO	Normal	R	A	S	V	-	-	-	1	OK or ERR	ERR
		16:9	R	A	S	V	-	-	-	2	OK or ERR	ERR
		Cinema Zoom	R	A	S	V	-	-	-	5	OK or ERR	ERR
		Zoom14:9	R	A	S	V	-	-	-	7	OK or ERR	ERR
		Smart Zoom	R	A	S	V	-	-	-	6	OK or ERR	ERR
		Normal	R	B	S	V	-	-	-	1	OK or ERR	ERR
	VIDEO	16:9	R	B	S	V	-	-	-	2	OK or ERR	ERR
		Cinema Zoom	R	B	S	V	-	-	-	5	OK or ERR	ERR
		Zoom14:9	R	B	S	V	-	-	-	7	OK or ERR	ERR
		Smart Zoom	R	B	S	V	-	-	-	6	OK or ERR	ERR
		Normal	R	B	S	V	-	-	-	1	OK or ERR	ERR
		16:9	R	B	S	V	-	-	-	2	OK or ERR	ERR
	Cinema Zoom	R	B	S	V	-	-	-	5	OK or ERR	ERR	
	Zoom14:9	R	B	S	V	-	-	-	7	OK or ERR	ERR	
	Smart Zoom	R	B	S	V	-	-	-	6	OK or ERR	ERR	

RS-232C Specifications and Commands (Continued)

Control Contents		Command				Parameter				Return		
										Power ON	Standby mode (or 30-second startup time)	
ALL Reset		A	L	R	E	--	--	--	1	OK or ERR	ERR	
COMPUTER INPUT	Picture Mode	Standard	R	A	P	S	--	--	--	1	OK or ERR	ERR
		Natural	R	A	P	S	--	--	--	2	OK or ERR	ERR
		Dynamic	R	A	P	S	--	--	--	3	OK or ERR	ERR
		Movie1	R	A	P	S	--	--	--	4	OK or ERR	ERR
		Movie2	R	A	P	S	--	--	--	5	OK or ERR	ERR
		Game	R	A	P	S	--	--	--	6	OK or ERR	ERR
	Contrast	-30 - +30	R	A	P	I	--	*	*	*	OK or ERR	ERR
	Bright	-30 - +30	R	A	B	R	--	*	*	*	OK or ERR	ERR
	Color	-30 - +30	R	A	C	O	--	*	*	*	OK or ERR	ERR
	Tint	-30 - +30	R	A	T	I	--	*	*	*	OK or ERR	ERR
	Sharp	-30 - +30	R	A	S	H	--	*	*	*	OK or ERR	ERR
	Red	-30 - +30	R	A	R	D	--	*	*	*	OK or ERR	ERR
	Blue	-30 - +30	R	A	B	E	--	*	*	*	OK or ERR	ERR
	CLR Temp	-2 - +2	R	A	C	T	--	--	*	*	OK or ERR	ERR
Picture Reset		R	A	R	E	--	--	--	1	OK or ERR	ERR	
COMPONENT INPUT	Picture Mode	Standard	R	B	P	S	--	--	--	1	OK or ERR	ERR
		Natural	R	B	P	S	--	--	--	2	OK or ERR	ERR
		Dynamic	R	B	P	S	--	--	--	3	OK or ERR	ERR
		Movie1	R	B	P	S	--	--	--	4	OK or ERR	ERR
		Movie2	R	B	P	S	--	--	--	5	OK or ERR	ERR
		Game	R	B	P	S	--	--	--	6	OK or ERR	ERR
	Contrast	-30 - +30	R	B	P	I	--	*	*	*	OK or ERR	ERR
	Bright	-30 - +30	R	B	B	R	--	*	*	*	OK or ERR	ERR
	Color	-30 - +30	R	B	C	O	--	*	*	*	OK or ERR	ERR
	Tint	-30 - +30	R	B	T	I	--	*	*	*	OK or ERR	ERR
	Sharp	-30 - +30	R	B	S	H	--	*	*	*	OK or ERR	ERR
	Red	-30 - +30	R	B	R	D	--	*	*	*	OK or ERR	ERR
	Blue	-30 - +30	R	B	B	E	--	*	*	*	OK or ERR	ERR
	CLR Temp	-2 - +2	R	B	C	T	--	--	*	*	OK or ERR	ERR
Picture Reset		R	B	R	E	--	--	--	1	OK or ERR	ERR	
HDMI1	Picture Mode	Standard	R	C	P	S	--	--	--	1	OK or ERR	ERR
		Natural	R	C	P	S	--	--	--	2	OK or ERR	ERR
		Dynamic	R	C	P	S	--	--	--	3	OK or ERR	ERR
		Movie1	R	C	P	S	--	--	--	4	OK or ERR	ERR
		Movie2	R	C	P	S	--	--	--	5	OK or ERR	ERR
		Game	R	C	P	S	--	--	--	6	OK or ERR	ERR
	Contrast	-30 - +30	R	C	P	I	--	*	*	*	OK or ERR	ERR
	Bright	-30 - +30	R	C	B	R	--	*	*	*	OK or ERR	ERR
	Color	-30 - +30	R	C	C	O	--	*	*	*	OK or ERR	ERR
	Tint	-30 - +30	R	C	T	I	--	*	*	*	OK or ERR	ERR
	Sharp	-30 - +30	R	C	S	H	--	*	*	*	OK or ERR	ERR
	Red	-30 - +30	R	C	R	D	--	*	*	*	OK or ERR	ERR
	Blue	-30 - +30	R	C	B	E	--	*	*	*	OK or ERR	ERR
	CLR Temp	-2 - +2	R	C	C	T	--	--	*	*	OK or ERR	ERR
Picture Reset		R	C	R	E	--	--	--	1	OK or ERR	ERR	
HDMI2	Picture Mode	Standard	R	D	P	S	--	--	--	1	OK or ERR	ERR
		Natural	R	D	P	S	--	--	--	2	OK or ERR	ERR
		Dynamic	R	D	P	S	--	--	--	3	OK or ERR	ERR
		Movie1	R	D	P	S	--	--	--	4	OK or ERR	ERR
		Movie2	R	D	P	S	--	--	--	5	OK or ERR	ERR
		Game	R	D	P	S	--	--	--	6	OK or ERR	ERR
	Contrast	-30 - +30	R	D	P	I	--	*	*	*	OK or ERR	ERR
	Bright	-30 - +30	R	D	B	R	--	*	*	*	OK or ERR	ERR
	Color	-30 - +30	R	D	C	O	--	*	*	*	OK or ERR	ERR
	Tint	-30 - +30	R	D	T	I	--	*	*	*	OK or ERR	ERR
	Sharp	-30 - +30	R	D	S	H	--	*	*	*	OK or ERR	ERR
	Red	-30 - +30	R	D	R	D	--	*	*	*	OK or ERR	ERR
	Blue	-30 - +30	R	D	B	E	--	*	*	*	OK or ERR	ERR
	CLR Temp	-2 - +2	R	D	C	T	--	--	*	*	OK or ERR	ERR
Picture Reset		R	D	R	E	--	--	--	1	OK or ERR	ERR	

Control Contents			Command				Parameter				Return		
											Power ON	Standby mode (or 30-second startup time)	
S-VIDEO INPUT	Picture Mode	Standard	V	A	P	S	_	_	_	1	OK or ERR	ERR	
		Natural	V	A	P	S	_	_	_	2	OK or ERR	ERR	
		Dynamic	V	A	P	S	_	_	_	3	OK or ERR	ERR	
		Movie1	V	A	P	S	_	_	_	4	OK or ERR	ERR	
		Movie2	V	A	P	S	_	_	_	5	OK or ERR	ERR	
		Game	V	A	P	S	_	_	_	6	OK or ERR	ERR	
	Contrast	-30 - +30	V	A	P	I	_	*	*	*	OK or ERR	ERR	
	Bright	-30 - +30	V	A	B	R	_	*	*	*	OK or ERR	ERR	
	Color	-30 - +30	V	A	C	O	_	*	*	*	OK or ERR	ERR	
	Tint	-30 - +30	V	A	T	I	_	*	*	*	OK or ERR	ERR	
	Sharp	-30 - +30	V	A	S	H	_	*	*	*	OK or ERR	ERR	
	Red	-30 - +30	V	A	R	D	_	*	*	*	OK or ERR	ERR	
	Blue	-30 - +30	V	A	B	E	_	*	*	*	OK or ERR	ERR	
	CLR Temp	-2 - +2	V	A	C	T	_	_	_	*	OK or ERR	ERR	
	Picture Reset		V	A	R	E	_	_	_	1	OK or ERR	ERR	
	VIDEO INPUT	Picture Mode	Standard	V	B	P	S	_	_	_	1	OK or ERR	ERR
Natural			V	B	P	S	_	_	_	2	OK or ERR	ERR	
Dynamic			V	B	P	S	_	_	_	3	OK or ERR	ERR	
Movie1			V	B	P	S	_	_	_	4	OK or ERR	ERR	
Movie2			V	B	P	S	_	_	_	5	OK or ERR	ERR	
Game			V	B	P	S	_	_	_	6	OK or ERR	ERR	
Contrast		-30 - +30	V	B	P	I	_	*	*	*	OK or ERR	ERR	
Bright		-30 - +30	V	B	B	R	_	*	*	*	OK or ERR	ERR	
Color		-30 - +30	V	B	C	O	_	*	*	*	OK or ERR	ERR	
Tint		-30 - +30	V	B	T	I	_	*	*	*	OK or ERR	ERR	
Sharp		-30 - +30	V	B	S	H	_	*	*	*	OK or ERR	ERR	
Red		-30 - +30	V	B	R	D	_	*	*	*	OK or ERR	ERR	
Blue		-30 - +30	V	B	B	E	_	*	*	*	OK or ERR	ERR	
CLR Temp		-2 - +2	V	B	C	T	_	_	_	*	OK or ERR	ERR	
Picture Reset			V	B	R	E	_	_	_	1	OK or ERR	ERR	
RGB Frequency Check		Horizontal	T	F	R	Q	_	_	_	1	kHz (***) or ERR)	ERR	
	Vertical	T	F	R	Q	_	_	_	2	Hz (***) or ERR)	ERR		
3D	On		3	D	E	N	_	_	_	1	OK or ERR	ERR	
	Off		3	D	E	N	_	_	_	0	OK or ERR	ERR	
	3D Format	Auto		3	D	F	M	_	_	_	0	OK or ERR	ERR
		Side By Side		3	D	F	M	_	_	_	1	OK or ERR	ERR
		Top And Bottom		3	D	F	M	_	_	_	2	OK or ERR	ERR
	Invert		3	D	I	V	_	_	_	1	OK or ERR	ERR	
Lamp Timer Reset *2		L	P	R	E	0	0	0	1	ERR	OK, ERR		

Note

- If an underbar (_) appears in the parameter column, enter a space. If an asterisk (*) appears, enter a value in the range indicated in brackets under Control Contents.

*1 For setting the projector name, send the commands in order of PJN1, PJN2 and PJN3.

*2 The Lamp Timer Reset command can only be sent in standby mode.



Compatibility Chart

Computer

- Multiple signal support
Horizontal Frequency: 15–110 kHz, Vertical Frequency: 43–85 Hz, Pixel Clock: 12–170 MHz
- Compatible with sync on green and composite sync signals (TTL level)

PC/MAC	Mode	Resolution	Horizontal frequency [kHz]	Vertical frequency [Hz]	Analog Support	Digital Support	Display
PC	VGA	640 × 400	27.0	60	✓		Upscale
			31.5	70	✓		
			37.9	85	✓		
		720 × 400	27.0	60	✓		
			31.5	70	✓	✓	
			37.9	85	✓		
		640 × 480	26.2	50	✓		
			31.5	60	✓	✓	
			34.7	70	✓		
			37.9	72	✓	✓	
			37.5	75	✓	✓	
			43.3	85	✓		
	SVGA	800 × 600	31.3	50	✓		
			35.2	56	✓	✓	
			37.9	60	✓	✓	
			46.6	70	✓		
			48.1	72	✓	✓	
			46.9	75	✓	✓	
		1024 × 768	53.7	85	✓		
			40.3	50	✓		
			48.4	60	✓	✓	
			56.5	70	✓	✓	
			60.0	75	✓	✓	
			68.7	85	✓		
	WXGA	1280 × 720	45.0	60	✓	✓	
			47.8	60	✓		
			49.7	60	✓		
			47.7	60	✓		
			47.8	60	✓		
	WXGA+	1440 × 900	55.9	60	✓		
55.0			60	✓	✓		
SXGA	1152 × 864	66.2	70	✓			
		67.5	75	✓	✓		
		60.0	60	✓	✓		
SXGA+	1280 × 960	64.0	60	✓	✓		
		64.0	60	✓	✓		
		64.0	60	✓	✓		
WSXGA+	1400 × 1050	65.3	60	✓	✓		
		65.3	60	✓	✓		
		1600 × 900	55.9	60	✓	✓	
		1680 × 1050	65.3	60	✓	✓	
MAC 13"	VGA	640 × 480	66.8	60	✓		Down sampled
			67.5	60	✓	✓	Intelligent Compression
MAC 16"	SVGA	832 × 624	34.9	67	✓		Upscale
MAC 19"	XGA	1024 × 768	49.7	75	✓		
MAC 21"	XGA	1024 × 768	60.2	75	✓		
MAC 21"	SXGA	1152 × 870	68.7	75	✓		

*1 When a 1920 × 1080 analog signal is input, the image is compressed before it is displayed on the screen.

*2 Full image display when "Resolution" is set to "1920 × 1080"

Note

- This projector may not be able to display images from notebook computers in simultaneous (CRT/LCD) mode. Should this occur, turn off the LCD display on the notebook computer and output the display data in "CRT only" mode. Details on how to change display modes can be found in your notebook computer's operation manual.
- When "Screen resolution" of the computer is different from the resolution displayed on the projected image, follow the procedures shown below.
 - Refer to "Resolution" on the "SIG-ADJ" menu and select the same resolution as the resolution in "Screen resolution" of the computer.
 - Depending on the computer you are using, the output signal may not be faithful to the "Screen resolution" adjustment. Check the settings of the computer's signal output. If the settings cannot be changed, it is recommended that the resolution be set to "1920 × 1080" or "1280 × 720".



DTV

Signal	Horizontal Frequency (kHz)	Vertical Frequency (Hz)	Analog Support	Digital Support	Signal	Horizontal Frequency (kHz)	Vertical Frequency (Hz)	Analog Support	Digital Support
480I	15.7	60	✓		1080I	28.1	50	✓	✓
480P	31.5	60	✓	✓	1080I	33.8	60	✓	✓
540P	33.8	60	✓		1080P	27.0	24		✓
576I	15.6	50	✓		1080P	28.1	25		✓
576P	31.3	50	✓	✓	1080P	33.8	30		✓
720P	37.5	50	✓	✓	1080P	56.3	50	✓	✓
720P	45.0	60	✓	✓	1080P	67.5	60	✓	✓

3D

Format	Signal	Horizontal Frequency (kHz)	Vertical Frequency (Hz)	Analog Support	Digital Support
Frame Packing	720P	75.0	50		✓
	720P	90.0	60		✓
	1080P	54.0	24		✓
Side By Side	720P	37.5	50		✓
	720P	45.0	60		✓
	1080I	28.1	50		✓
	1080I	33.8	60		✓
	1080P	56.3	50		✓
	1080P	67.5	60		✓
	1080P	67.5	60		✓
Top And Bottom	720P	37.5	50		✓
	720P	45.0	60		✓
	1080P	27.0	24		✓
	1080P	56.3	50		✓
	1080P	67.5	60		✓

Troubleshooting

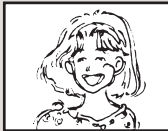
Problem	Check	Page
 <p>No picture or projector does not start</p>	<ul style="list-style-type: none"> • Projector power cord is not plugged into the wall outlet. 	23
	<ul style="list-style-type: none"> • Power to the external connected devices is off. 	–
	<ul style="list-style-type: none"> • The lens shutter is closed. 	23, 28
	<ul style="list-style-type: none"> • The selected input mode is wrong. 	27, 41, 42
	<ul style="list-style-type: none"> • Cables are incorrectly connected to the projector. 	19-23
	<ul style="list-style-type: none"> • Remote control battery has run out. 	13
	<ul style="list-style-type: none"> • External output has not been set when connecting notebook computer. 	–
	<ul style="list-style-type: none"> • The lamp unit cover is not installed correctly. 	63, 64
	<ul style="list-style-type: none"> • The selected “Signal Type” is wrong. 	41
	<ul style="list-style-type: none"> • The video signal format of the video equipment is not set correctly. 	42
 <p>Color is faded or poor.</p>	<ul style="list-style-type: none"> • “Bright” is set to minimum position. 	37
	<ul style="list-style-type: none"> • Image adjustments are incorrectly set. 	37
	(S-VIDEO or VIDEO input) <ul style="list-style-type: none"> • Video input system is incorrectly set. (COMPONENT, COMPUTER/COMPONENT or HDMI1, 2 input) <ul style="list-style-type: none"> • Input signal type is incorrectly set. 	42 41
 <p>Picture is blurred; noise appears.</p>	<ul style="list-style-type: none"> • Adjust the focus. 	24
	<ul style="list-style-type: none"> • The projection distance exceeds the focus range. 	18
	(Computer input) <ul style="list-style-type: none"> • Perform “SIG-ADJ” Adjustments (“Clock” Adjustment) • Perform “SIG-ADJ” Adjustments (“Phase” Adjustment) • Noise may appear depending on the computer. 	41 41 –
	<ul style="list-style-type: none"> • The “DNR” (Digital Noise Reduction) or “MNR” (Mosquito Noise Reduction) setting is not correct. 	40
	<ul style="list-style-type: none"> • There is fog on the lens. If the projector is carried from a cold room into a warm room, or if it is suddenly heated, condensation may form on the surface of the lens and the image will become blurred. Please set up the projector at least one hour before it is to be used. If condensation should form, remove the power cord from the wall outlet and wait for it to clear. 	–
<p>An unusual sound is occasionally heard from the cabinet.</p>	<ul style="list-style-type: none"> • If the picture is normal, the sound is due to cabinet shrinkage caused by a room temperature changes. This will not affect operation or performance. 	–
<p>Maintenance indicator on the projector illuminates.</p>	<ul style="list-style-type: none"> • See “Maintenance Indicators”. 	60
<p>Picture is green when receiving YPbPr signals and the video equipment is connected to the COMPONENT or COMPUTER/COMPONENT terminal on the projector.</p>	<ul style="list-style-type: none"> • Change the input signal type setting. 	41
<p>Picture is pink when receiving RGB signals and the video equipment is connected to the COMPONENT or COMPUTER/COMPONENT terminal on the projector.</p>		
<p>The black levels of the image show banding or appear faded when HDMI1 or 2 is selected.</p>	<ul style="list-style-type: none"> • Make adjustments that result in the best picture quality in the “Dynamic Range” setting. 	42
<p>Picture is too bright and whitish.</p>	<ul style="list-style-type: none"> • Image adjustments are incorrectly set. 	37

Problem	Check	Page
The cooling fan becomes noisy.	<ul style="list-style-type: none"> When temperature inside the projector increases, the cooling fan runs faster. 	–
The lamp does not light up even after the projector turns on.	<ul style="list-style-type: none"> The lamp indicator is illuminating in red. Replace the lamp. The lens shutter is opened fully. 	23, 60, 63
The lamp suddenly turns off during projection.		
The image sometimes flickers.	<ul style="list-style-type: none"> Cables are incorrectly connected to the projector or the connected equipment works improperly. If this happens frequently, replace the lamp. 	19-22
		63
The lamp needs much time to turn on.	<ul style="list-style-type: none"> The lamp will eventually need to be changed. While the remaining lamp life draws to a close, replace the lamp. 	63
Picture is dark.		
One Touch Play is not enabled.	<ul style="list-style-type: none"> Non-Sharp Video Products are connected. One Touch Play function may not work when the projector is connected to non-Sharp Video Products. 	46
	<ul style="list-style-type: none"> An HDMI cable is not used for connection between the projector and the Sharp Video Products. One Touch Play function is enabled when the projector is connected to the Sharp Video Products with an HDMI cable. 	20
	<ul style="list-style-type: none"> One Touch Play function of the projector is not set to “On”. 	46
	<ul style="list-style-type: none"> CEC settings of connected Sharp Video Products or other CEC devices are incorrect. 	–
	<ul style="list-style-type: none"> One Touch Play is set to “Off” and disabled when the Economy mode is set to “On”. 	46
System Standby is not enabled.	<ul style="list-style-type: none"> Non-Sharp Video Products are connected. System Standby function may not work when the projector is connected to non-Sharp Video Products. 	46
	<ul style="list-style-type: none"> An HDMI cable is not used for connection between the projector and the Sharp Video Products. System Standby function is enabled when the projector is connected to the Sharp Video Products with an HDMI cable. 	20
	<ul style="list-style-type: none"> System Standby function of the projector is not set to “On”. 	46
	<ul style="list-style-type: none"> CEC settings of connected Sharp Video Products or other CEC devices are incorrect. 	–
A response code cannot be received when the projector was attempted to be controlled using RS-232C commands from a computer during standby.	<ul style="list-style-type: none"> In the case of transmitting RS-232C commands from a computer during standby, it takes a maximum of 30 seconds for the computer to receive the response code. Set the response code waiting time of the computer to 30 seconds or more. 	66
The remote control cannot be used.	<ul style="list-style-type: none"> Operate the remote control while pointing it at the projector’s remote control sensor. The remote control may be too far away from the projector. If direct sunlight or a strong fluorescent light is shining on the projector’s remote control sensor, place the projector where it will not be affected by strong light. 	13
		13
		13
	<ul style="list-style-type: none"> The batteries may be depleted or inserted incorrectly. Make sure the batteries are inserted correctly or insert new ones. 	13

Troubleshooting (Continued)

Problem	Check	Page
3D images are not displayed.	<ul style="list-style-type: none"> • Switch to 3D mode. 	53, 54, 55
	<ul style="list-style-type: none"> • Is “3D Auto Change” set to “No”? Press 3D ON/OFF to switch to 3D mode. 	55
	<ul style="list-style-type: none"> • If “3D Auto Change” is set to “Yes” but no 3D images are displayed, check the display format of the content being viewed. Some 3D image signals may not be recognized as 3D images automatically. Press 3D MENU to select the appropriate display format for the 3D image. 	55, 56
	<ul style="list-style-type: none"> • The 3D Glasses are not turned on. 	52
	<ul style="list-style-type: none"> • The 3D Glasses are set to 2D mode. 	52
	<ul style="list-style-type: none"> • The 3D Glasses operate by receiving the infrared signal reflected onto the screen. Do not place anything between the screen and the infrared receiver on the 3D Glasses. 	–
3D Images flicker when watching in a room.	<ul style="list-style-type: none"> • Images may appear to flicker when fluorescent light or ambient light enters your vision. <ul style="list-style-type: none"> -Turn off the lights. -Block any ambient light. 	–
Ghosting (a double image) occurs without the image appearing in 3D.	<ul style="list-style-type: none"> • Use “Invert” to change the setting. 	55
	<ul style="list-style-type: none"> • A signal that does not support 3D is being received. Check whether a signal that supports 3D is being received. 	71
	<ul style="list-style-type: none"> • If the projector is connected to a computer for 3D image playback, check that a stereoscopically-enabled application is being used. <ul style="list-style-type: none"> - Use the applicable software - Configure your 3D application at the correct 3D format, resolution and refresh rate. To support 3D, your 3D application must be configured to run at the correct settings for this projector. 	–
	<ul style="list-style-type: none"> • If there is strong ambient light, block the light. High intensity lighting can interfere with communication between the 3D Glasses and the screen, resulting in some flicker. 	–
	<ul style="list-style-type: none"> • A picture simultaneously projected from more than two projectors may not appear 3D. Use only one projector at a time. 	–
The projected image is dark.	<ul style="list-style-type: none"> • When a 3D image is projected, the screen may appear darker than normal. 	–
The 3D Glasses turn off automatically.	<ul style="list-style-type: none"> • Is there an obstacle between the 3D Glasses and the screen, or is something covering the infrared receiver on the 3D Glasses? The 3D Glasses turn off automatically after 3 minutes if no signal is received. Do not place anything between the screen and the infrared receiver on the 3D Glasses. 	–
Pressing the power button on the 3D Glasses does not cause the LED light to light.	<ul style="list-style-type: none"> • The battery in the 3D Glasses is exhausted. If the LED light does not light after pressing the power button for more than one second, the battery is exhausted. Replace the battery. 	51

This unit is equipped with a microprocessor. Its performance could be adversely affected by incorrect operation or interference. If this should happen, unplug the unit and plug it in again after more than 5 minutes.

For SHARP Assistance

If you encounter any problems during setup or operation of this projector, first refer to the “Troubleshooting” section on pages 72 to 74. If this operation manual does not answer your question, please contact the SHARP Service departments listed below.

U.S.A.	Sharp Electronics Corporation 1-888-GO-SHARP (1-888-467-4277) lcdsupport@sharpsec.com http://www.sharppusa.com	Benelux	SHARP Electronics Benelux BV 0900-SHARPC (0900-7427723) Nederland 9900-0159 Belgium http://www.sharp.nl http://www.sharp.be http://www.sharp.lu
Canada	Sharp Electronics of Canada Ltd. (905) 568-7140 http://www.sharp.ca	Australia	Sharp Corporation of Australia Pty. Ltd. 1300-135-022 http://www.sharp.net.au
Mexico	Sharp Electronics Corporation Mexico Branch (525) 716-9000 http://www.sharp.com.mx	New Zealand	Sharp Corporation of New Zealand Phone: (09) 573-0111 Fax: (09) 573-0112 http://www.sharp.net.nz
Latin America	Sharp Electronics Corp. Latin American Group (305) 264-2277 www.servicio@sharpsec.com http://www.siemprisharp.com	Singapore	Sharp-Roxy Sales (S) Pte. Ltd. 65-226-6556 ckng@srs.global.sharp.co.jp http://www.sharp.com.sg
Germany	Sharp Electronics (Europe) GMBH 01805-234675 http://www.sharp.de	Hong Kong	Sharp-Roxy (HK) Ltd. (852) 2410-2623 dcmktg@srh.global.sharp.co.jp http://www.sharp.com.hk
U.K.	Sharp Electronics (U.K.) Ltd. 08705 274277 http://www.sharp.co.uk/customer-support	Taiwan	Sharp Corporation (Taiwan) 0800-025111 http://www.sharp-scot.com.tw
Italy	Sharp Electronics (Italy) S.P.A. (39) 02-89595-1 http://www.sharp.it	Malaysia	Sharp-Roxy Sales & Service Co. (60) 3-5125678
France	Sharp Electronics France 01 49 90 35 40 hotlinecd@sef.sharp-eu.com http://www.sharp.fr	U.A.E.	Sharp Middle East Fze 971-4-81-5311 helpdesk@smef.global.sharp.co.jp
Spain	Sharp Electronica Espana, S.A. 93 5819700 sharpplcd@sees.sharp-eu.com http://www.sharp.es	Thailand	Sharp Thebnakorn Co. Ltd. 02-236-0170 svc@stcl.global.sharp.co.jp http://www.sharp-th.com
Switzerland	Sharp Electronics (Schweiz) AG 0041 1 846 63 11 cattaneo@sez.sharp-eu.com http://www.sharp.ch	Korea	Sharp Electronics Incorporated of Korea (82) 2-3660-2002 lcd@sharp-korea.co.kr http://www.sharpkorea.co.kr
Sweden	Sharp Electronics (Nordic) AB (46) 8 6343600 vision.support@sen.sharp-eu.com http://www.sharp.se	India	Sharp Business Systems (India) Limited (91) 11- 6431313 service@sharp-oa.com
Austria	Sharp Electronics (Europe) GMBH Branch Office Austria 0043 1 727 19 123 pogats@sea.sharp-eu.com http://www.sharp.at		



Specifications

Model		XV-Z17000
Display devices		0.65" DLP® Chip × 1
Resolution		1080P (1920 × 1080)
Lens	F number	F 2.5 – 2.7
	Zoom	Manual, ×1.15 (f = 21.0 – 24.2 mm)
	Focus	Manual
Input terminals	HDMI	× 2
	Computer/Component (mini D-sub 15 pin)	× 1
	Component (3RCA)	× 1
	S-Video (mini DIN 4 pin)	× 1
	Video (RCA)	× 1
Control and communication terminals	RS-232C (mini D-sub 9 pin)	× 1
Projection lamp		250 W
Rated voltage		AC 100 – 240V
Rated frequency		50/60 Hz
Input current		3.7 A
Power consumption (Standby)		353 W (7.6 W) with AC 100 V 339 W (8.3 W) with AC 240 V
Operation temperature		41°F to 95°F (+5°C to +35°C)
Cabinet		Plastic
Dimensions (main body only) [W × H × D]		15 ³ / ₄ " × 3 ¹⁵ / ₁₆ " × 13 ¹³ / ₆₄ " (400 × 100 × 335 mm)
Weight (approx.)		12.8 lbs. (5.8 kg)

As a part of policy of continuous improvement, SHARP reserves the right to make design and specification changes for product improvement without prior notice. The performance specification figures indicated are nominal values of production units. There may be some deviations from these values in individual units.

This SHARP projector uses a DLP® chip. This very sophisticated panel contains 2,073,600 pixels (micromirrors). As with any high technology electronic equipment such as large screen TVs, video systems and video cameras, there are certain acceptable tolerances that the equipment must conform to. This unit has some inactive pixels within acceptable tolerances which may result in inactive dots on the picture screen. This will not affect the picture quality or the life expectancy of the unit.



Dimensions

Units: inches (mm)

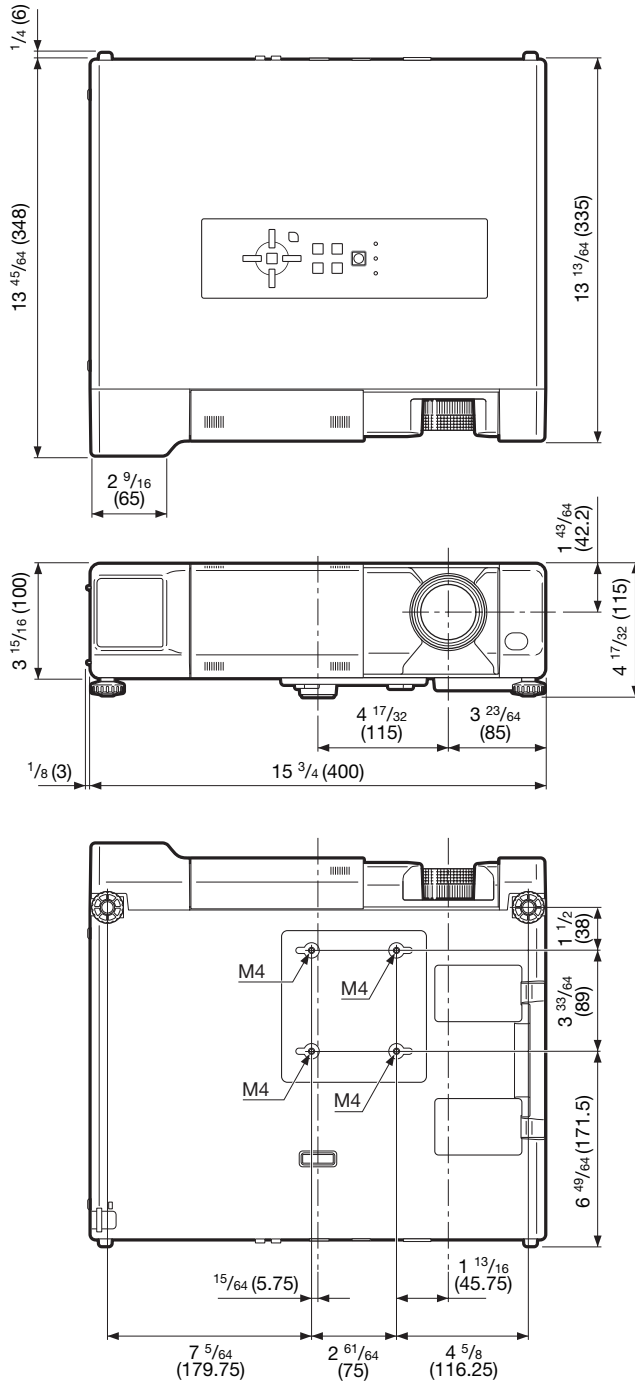



Index

16:9.....	30	Lamp indicator	60
3D Auto Change.....	55	Lamp Timer (Life).....	47
3D Depth Adjust.....	55	Language (on-screen display language)	45
3D Format.....	55	Lens shutter.....	23, 28, 63
3D Glasses	50-52	MAGNIFY buttons	29
3D MENU	55	MENU HIDE button	29
3D MENU button.....	54, 55	MENU button.....	35
3D ON/OFF button	53, 54	MNR	40
Accessories.....	9	Movie1, 2.....	37
AC socket.....	23	NATIVE.....	31
Adjustment buttons	35	Natural	37
Adjustment feet	24	ON button.....	23
Advanced	38	One Touch Play	46
All Reset	47	On-screen Display	45
Auto Power Off.....	46	Optional accessories.....	9
Auto Sync.....	41	OSD Brightness.....	45
AUTO SYNC button	28	Overscan	43
Background.....	45	Phase.....	41
Batteries	13	Picture	37
Bright.....	37	Picture Mode	37
Bright Boost	40	PICTURE MODE button	28
Carrying handle	11	Power cord	9, 23
Ceiling-mount setup.....	17	Power indicator	23, 60
CINEMA ZOOM.....	30	PRJ-ADJ.....	46
Clock	41	PRJ mode.....	17, 45
CLR Temp (Color Temperature).....	37	Remote control.....	12
C.M.S.	38	Remote control sensors	13
Color.....	37	Replacing the lamp	62
COMPONENT button	27	RESIZE button.....	30
COMPONENT terminal.....	19	RETURN button.....	35
COMPUTER button.....	27	Rotation.....	26, 45
COMPUTER/COMPONENT terminal	19, 21	RS-232C.....	47
Contrast.....	37	RS-232C terminal.....	22
Detail Enhance	40	Saturation	39
DNR.....	40	SCR-ADJ	43
Dynamic	37	Screen Size and Projection Distance	18
Dynamic Range	42	Security bar	11
Economy Mode	46	Select Color.....	39
ECO+QUIET button.....	29	Sharp.....	37
Effect	39	SIG-ADJ	41
ENTER button.....	35	Signal Info.....	42
Fan Mode	47	Signal Type	41
Film Mode.....	40	SMART ZOOM	31
Focus ring.....	24	Sphere	26, 44
FREEZE button.....	28	Standard.....	37
Game.....	37	STANDBY button.....	23
Gamma.....	38	STANDBY/ON button	23
HDMI1, 2 buttons.....	27	S-VIDEO button.....	27
HDMI1, 2 terminals.....	19, 20	S-VIDEO terminal	19, 20
HEIGHT ADJUST lever	24	System Standby	46
H-Image Shift	27, 43	Temperature warning indicator.....	60
H-Pos	41	Tint.....	37
Hue.....	39	Value.....	39
IMAGE SHIFT button.....	27	VIDEO button	27
INPUT button.....	27	Video Setup	42
Input Name.....	47	Video System	42
Invert.....	55	VIDEO terminal	19
IR Emitter Level	55	Viewing Time Info	55
IRIS1, 2.....	38	V-Image Shift.....	27, 43
IRIS1, 2 buttons.....	29	V-Pos.....	41
Kensington Security Standard connector	11	ZOOM 14:9.....	31
KEystone button	25	Zoom ring	24

SHARP®

SHARP CORPORATION

Printed in China
Imprimé en Chine
Impreso en China
Impresso na China
TINS-E929WJZZ
11P01-CH-NM