

myprojectorlamps.com

**The most trusted, dependable name
in projector lamp sales.**



<http://www.myprojectorlamps.com>



<http://www.myprojectorlamps.ca>



<http://www.myprojectorlamps.eu>

The following projector manual has not been modified or altered in any way.

PLUS

User's Manual

HE-3100



English

Important Safety Information

Please read this manual carefully before using the projector and keep the manual handy for future reference.

CAUTION

**RISK OF ELECTRIC SHOCK
DO NOT REMOVE SCREWS
EXCEPT SPECIFIED USER
SERVICE SCREW.**

CAUTION: TO REDUCE THE RISK OF ELECTRIC SHOCK, DO NOT REMOVE COVER. NO USER-SERVICEABLE PARTS INSIDE. REFER SERVICING TO QUALIFIED SERVICE PERSONNEL.



This symbol warns the user that uninsulated voltage within the unit may have sufficient magnitude to cause electric shock. Therefore, it is dangerous to make any kind of contact with any part inside of this unit.



This symbol alerts the user that important literature concerning the operation and maintenance of this unit has been included. Therefore, it should be read carefully in order to avoid any problems.

The above cautions are given on the bottom of the product.



CAUTION
To turn off main power, be sure to remove the plug from the power outlet.
The power outlet socket should be installed as near to the equipment as possible, and should be easily accessible.



WARNING
TO PREVENT FIRE OR SHOCK HAZARDS, DO NOT EXPOSE THIS UNIT TO RAIN OR MOISTURE. ALSO DO NOT USE THIS UNIT'S POLARIZED PLUG WITH AN EXTENSION CORD RECEPTACLE OR OTHER OUTLETS, UNLESS THE PRONGS CAN BE FULLY INSERTED. REFRAIN FROM OPENING THE CABINET AS THERE ARE HIGH-VOLTAGE COMPONENTS INSIDE. REFER SERVICING TO QUALIFIED SERVICE PERSONNEL.

DOC compliance Notice

This Class B digital apparatus meets all requirements of the Canadian Interference-Causing Equipment Regulations.

WARNING

This equipment has been tested and found to comply with the limits for a Class B digital device, pursuant to Part 15 of the FCC Rules. These limits are designed to provide reasonable protection against harmful interference in a residential installation. This equipment generates, uses and can radiate radio frequency energy and, if not installed and used in accordance with the instructions, may cause harmful interference to radio communications. However, there is no guarantee that interference will not occur in a particular installation. If this equipment does cause harmful interference to radio or television reception, which can be determined by turning the equipment off and on, the user is encouraged to try to correct the interference by one or more of the following measures:

- Reorientate or relocate the receiving antenna.
- Increase the separation between the equipment and receiver.
- Connect the equipment into an outlet on a circuit different from that to which the receiver is connected.
- Consult the dealer or an experienced radio/TV technician for help.

Turning ON or OFF Main Power

Make all hookups before turning on the main power.

To turn on the main power:

Press the POWER switch down until it is in the depressed position.

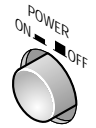

Light in orange



POWER /  STATUS

Main power ON

On condition

To turn off the main power:

Press the POWER switch until it is in the protruded position.



Indicator OFF



POWER /  STATUS

Main power OFF

Off condition

Installation

- * Allow at least 10 cm (3.9 inch) of space between the projector top panel and its surroundings. Also allow at least 10 cm (3.9 inch) of other spaces around the projector.
- * The projector should be placed on a flat, level surface and in a dry area free from dust and moisture.
- * The projector should always be handled with care. Dropping or jarring the projector could damage internal components.
- * If you wish to have the projector installed on the ceiling do not attempt to install the projector yourself. The projector must be installed in accordance with any local building codes by qualified technicians in order to ensure proper operation and reduce the risk of bodily injury.
- * Do not place this product near water, near a bathtub, in a wet basement or near a swimming pool and the like.

Power supply

- * The projector is designed to operate on a power supply of 100-240V AC, 50/60Hz. Ensure that your power supply fits this requirement before attempting to use your projector.
- * Handle the power cable carefully and avoid excessive bending. A damaged cord can cause electric shock or fire.
- * If the projector is not be used for an extended period of time, disconnect the plug from the power outlet. Do not unplug the power cable from the wall outlet under the following circumstances, doing so may cause damage to the projector:

Cleaning

- * Unplug the projector before cleaning.
- * Use a blower or lens paper to clean the lens, and be careful not to scratch or mar the lens.

Lamp Replacement

Be sure to replace the lamp when the message "Replace The Lamp" appears on the screen. If you continue to use the lamp after 1100 hours of usage, the lamp will not turn on. To replace the lamp, follow all instructions on page E-40.

Fire and Shock Precautions

- * The openings should never be covered or blocked by placing the product on a bed, sofa, rug, or other similar surface.
- * Prevent foreign objects such as paper clips and bits of paper from falling into the projector. Do not attempt to retrieve any objects that fell into the projector.
- * Do not insert any metal objects such as a wire or screwdriver into the projector. If something should fall into the projector, immediately disconnect the power cord from the projector and have the object removed by a qualified service person.
- * Do not place any liquids on top of the projector.

Do not look into the lens while the projector is on. Serious damage to your eyes could result.

IMPORTANT SAFETY INSTRUCTIONS

1) Read these instructions.

All the safety and operating instructions should be read before the product is operated.

2) Keep these instructions.

The safety and operating instructions should be retained for future reference.

3) Heed all warnings.

All warnings on the product and in the operating instructions should be adhered to.

4) Follow all instructions.

All instructions should be followed.

5) Do not use this apparatus near water.

Do not use this product near water, near a bathtub, in a wet basement or near a swimming pool and the like.

6) Cleaning

Clean only with dry cloth.

7) Ventilation

Do not block any ventilation openings. Install in accordance with the manufacturer's instructions.

8) Heat

Do not install near any heat sources such as radiators, heat registers, stoves, or other apparatus (including amplifiers) that produce heat.

9) Grounding or Polarization

Do not defeat the safety purpose of the polarized or grounding-type plug. A polarized plug has two blades with one wider than the other. A grounding type plug has two blades and a third grounding prong. The wide blade or the third prong are provided for your safety. If the provided plug does not fit into your outlet, consult an electrician for replacement of the obsolete outlet.

10) Power-Cable Protection

Protect the power cord from being walked on or pinched particularly at plugs, convenience receptacles, and the point where they exit from the apparatus.

11) Attachments/Accessories

Only use attachments/accessories specified by the manufacturer.

12) Transportation

Use only with the cart, stand, tripod, bracket, or table specified by the manufacturer, or sold with the apparatus. When a cart is used, use caution when moving the cart/apparatus combination to avoid injury from tip-over.



13) Lightning

Unplug this apparatus during lightning storms or when unused for long periods of time.

14) Servicing

Refer all servicing to qualified service personnel. Servicing is required when the apparatus has been damaged in any way, such as power-supply cord or plug is damaged, liquid has been spilled or objects have fallen into the apparatus, the apparatus has been exposed to rain or moisture, does not operate normally, or has been dropped.

Major Features

High Image Quality

Use of a Digital Micromirror Device (DMD™) chip that is based on Texas Instrument's Digital Light Processing (DLP™) technology enables images of high contrast and high detail.

- DLP technology gives rise to devices that exhibit high response speed, which in turn enables excellent moving picture characteristics and smooth images.
- Use of a high-performance progressive scan converter provides reproduction of film-like images.
- Built-in color filters of high purity permit the reproduction of vivid color images.

Quiet Design

PLUS Vision Corporation's quiet design technology has resulted in a great reduction of fan noise which allows quiet performance that doesn't interfere with the enjoyment of movie watching in an indoor environment.

Installation Flexibility

The compact design (of about B5 paper size: 182 x 257 mm / 7.2 x 10.1 inch) and mere 2 kg / 4.4 lbs weight has resulted in a projector that can be carried anywhere indoors for room-to-room portability.

* Digital Light Processing, DLP, Digital Micromirror Device and DMD are trademarks of Texas Instruments Incorporated.

* DLP technology is the combination of DLP technology and digitally control DMD™, super micro electronic components which replace LCD technology.

* VGA and XGA are trademarks or registered trademarks of International Business Machines Corporation in the USA.

* S-VGA is a registered trademark of Video Electronics Standards Association.

* TMDSI is a trademark of Silicon Image, Inc.

All company and/or product names are trademarks and/or registered trademarks of their respective manufacturers.

Table of Contents

Important Safety Information	E-2	Input Video Adjustments [Picture 2]	E-30
IMPORTANT SAFETY INSTRUCTIONS	E-3	Adjusting the Sharpness of the Video Image	E-30
Major Features	E-4	Adjusting the Sharpness When Expanding/Compressing	E-30
Accessories Check	E-6	ProScan Mode Settings	E-30
Names of the Main Unit Parts	E-7	Adjustment of Screen Display Position	E-31
Using the Storage Case	E-9	Gamma Settings	E-31
Attaching the Supplied Adjusters	E-9	Video Signal Color System Settings	E-32
Names of the Remote Control Parts	E-10	Setup	E-33
Preparing the Remote Control	E-11	Adjustment of Keystone Distortion	E-33
Inserting the Batteries	E-11	Screen Projection System Settings	E-33
Remote Control Range	E-11	Background Color Settings	E-34
The Procedure Up to Projecting to the Screen	E-12	Auto Standby Settings	E-34
Placement Guide	E-13	LED Display Settings	E-34
Projection Distance and Screen Size	E-13	On-Screen Display Settings [Option]	E-35
Power Cord Connections	E-14	On-Screen Display Language Settings	E-35
Power Cord Connections	E-14	Moving the Menu Display Position	E-35
Connecting Video Equipment and Personal Computers	E-15	On-Screen Display Duration Setting	E-35
Connections with VIDEO and S-VIDEO Connectors	E-15	Resetting, Storing, and Information [Info.]	E-36
Connections with YCbCr Connectors	E-16	Saving and Loading of Video Adjustments	E-36
Connection with DVI-D Connector	E-17	Returning to Standard Settings	E-37
Turning ON or OFF Main Power	E-18	Resetting the Lamp Timer	E-37
Turning ON or OFF Main Power	E-18	Viewing the Lamp Timer/Resolution and Frequency	E-37
Turning ON or OFF Power	E-18	Troubleshooting	E-38
Adjustment of the Projection Screen	E-19	When the STATUS Indicator Is Lit/Flashes	E-39
Projection Screen Position Adjustment	E-19	Replacing the Lamp Cartridge	E-40
Focus Adjustment	E-19	Cleaning	E-42
Input Selection	E-20	Specifications	E-43
Selection of Aspect Ratio	E-20	Main Unit External View	E-44
Input Screen and Aspect Ratio Selection Screen	E-21		
Operation with the Remote Control	E-22		
Turning ON Power/STANDBY	E-22		
Input Selection	E-23		
Selection of Aspect Ratio	E-23		
Using the On-Screen Menu	E-24		
Menu List	E-27		
Video Adjustments [Picture 1]	E-29		
Adjusting the Picture	E-29		
Adjusting the White Balance	E-29		

Accessories Check

Remove the main unit and the accessories from the box and check that the following items are included. Should an accessory be missing, please contact your store of purchase.

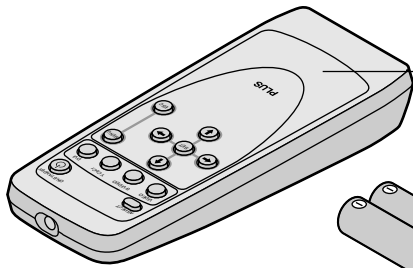

Remote control × 1
Controls the projector.

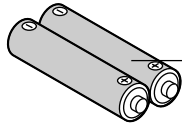

AA Batteries × 2
These batteries are for the remote control. Insert the batteries at time of purchase.
See → Page E-11.

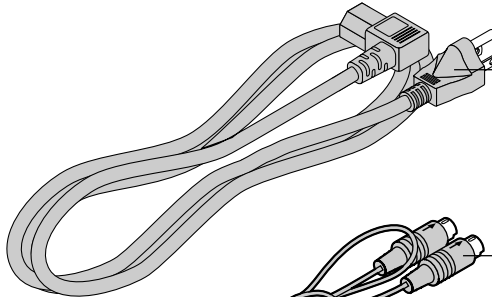

Power cord (1.8 m / 5.9 feet)
This power cord supplies power to the unit. See → Page E-14 about connections.

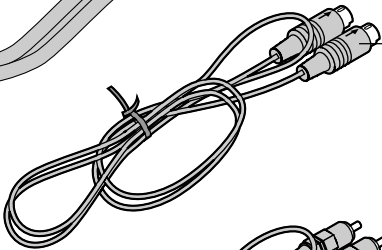

S-Video cable (2 m / 6.6 feet) No. 771709000
This cable is used when the output connector of the equipment to be connected is an S-video connector. Connections are described on → Page E-15.

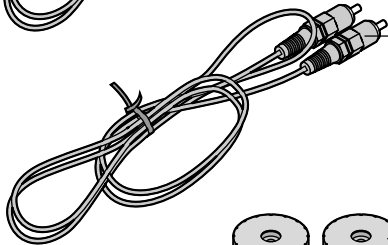

Video cable (2 m / 6.6 feet) No. 771703000
This cable is used when the output connector of the external equipment is a video connector. Connections are described on → Page E-15.

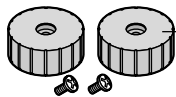

Adjuster × 2 / Screw × 2
The adjusters and screws are required for fine vertical adjustment of the projector.
See → Page E-9 for attachment and Page E-19 for adjustment.

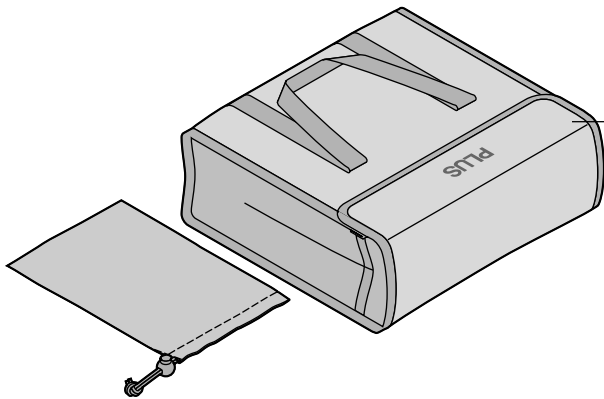

Storage case × 1 / Cable pouch × 1
This case houses the main unit and the accessories.
Using Storage case → Page E-9.

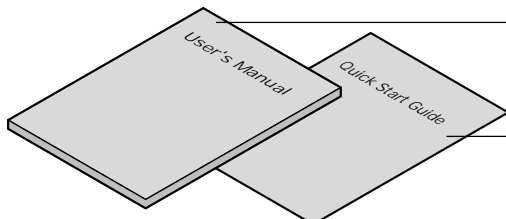

Users Manual × 1
Includes information about handling of the projector, the operation method, and precautions.

Quick Start Guide × 1
Consolidates the procedures from setup to projecting the picture.

Names of the Main Unit Parts

Attention!
 Pay special attention to the ventilation outflow holes. The heat from the lamp is discharged from the ventilation outflow holes.

Ventilation outflow holes
 These ventilation outflow holes used for cooling the main unit and discharge the heat of the lamp.

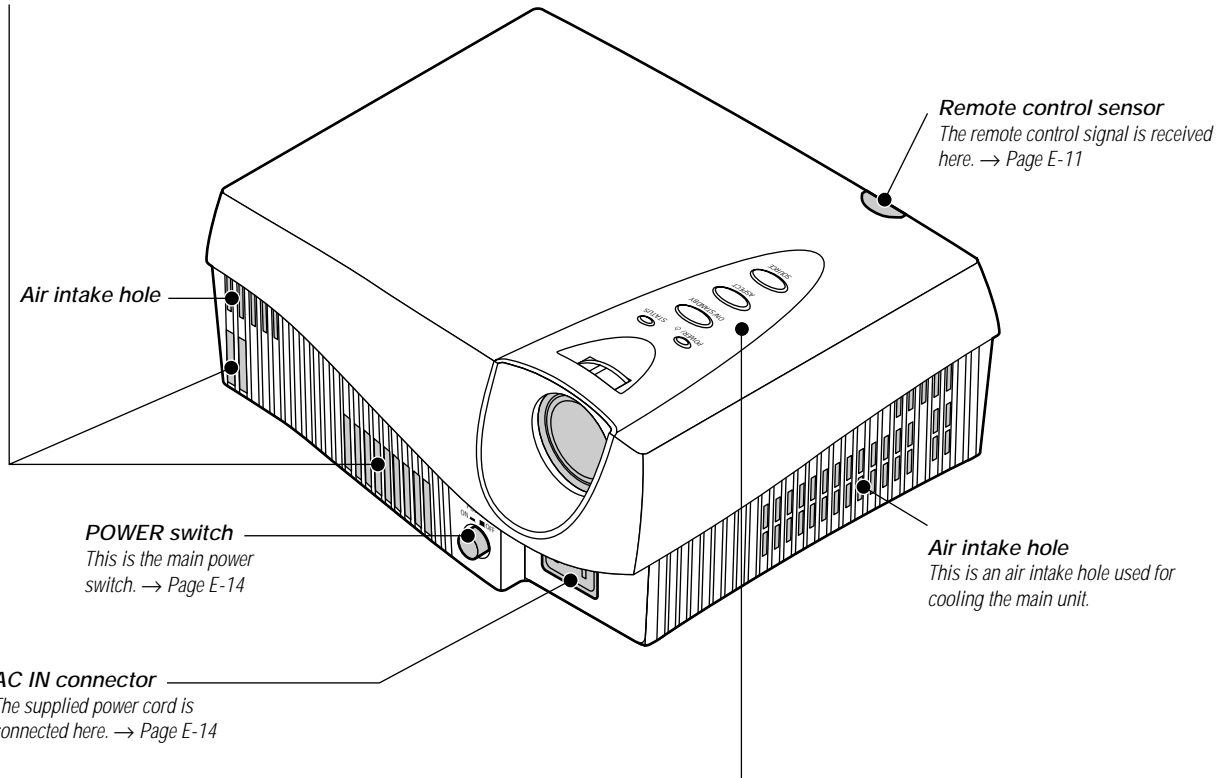

POWER/⏻ (STANDBY) indicator
 On and Standby operation modes are indicated when this indicator is flashing green or lit orange. The indicator is not lit when the POWER switch is "off." → Page E-18

ASPECT button
 This button selects the aspect ratio (i.e., the ratio of screen width and height) of the input video. → Page E-20

SOURCE button
 This button selects the input signal of the main unit that will be used for the connections. → Page E-20

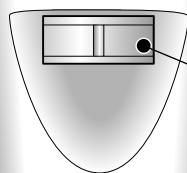

FOCUS ring
 This adjusts the focus of the projected picture. → Page E-19

STATUS indicator
 Lit/flashing serve to indicate the main unit temperature, lamp, lamp cover, lamp cartridge, and fan conditions. → Page E-39

ON/STANDBY button
 This button is used to switch ON the power and set the unit to the STANDBY mode. → Page E-18

Names of the Main Unit Parts

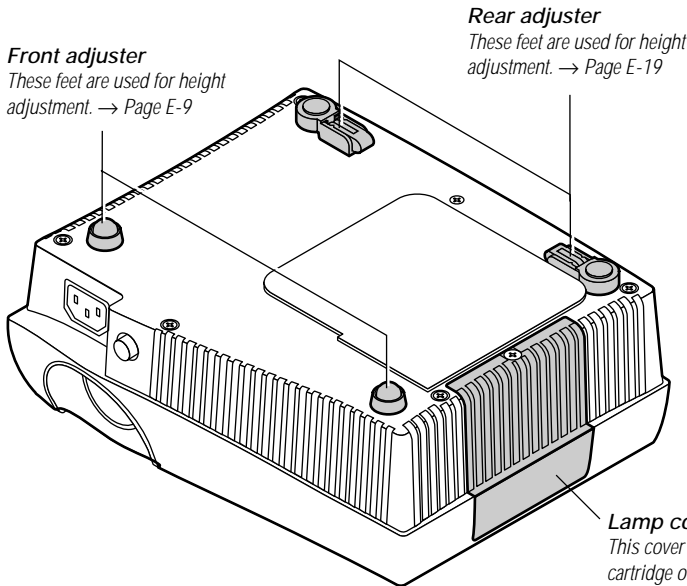
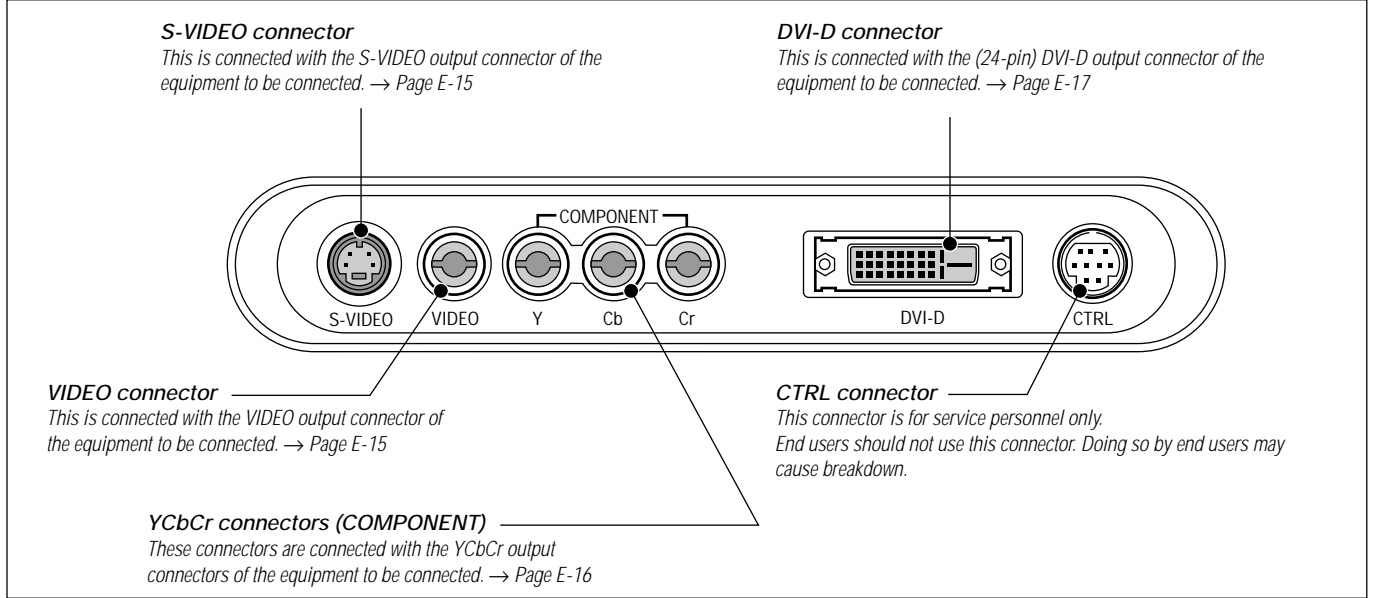
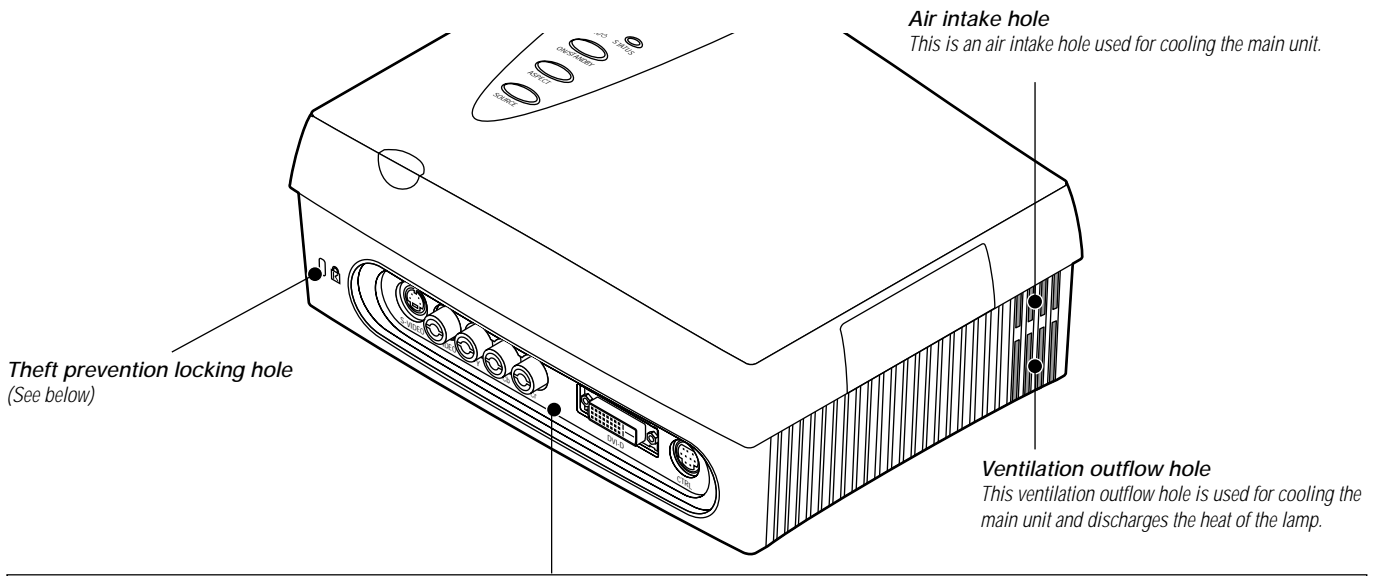

Theft Prevention Lock

The theft prevention lock is supported by the Micro Saver Security System manufactured by Kensington Technology Group.

Using the Storage Case

Please use the supplied storage case for storing the main unit.

The remote control pocket of the storage case will conveniently hold the remote control.

To avoid scratches to the main unit, collect the power cord and connection cables and place them in the cable pouch.

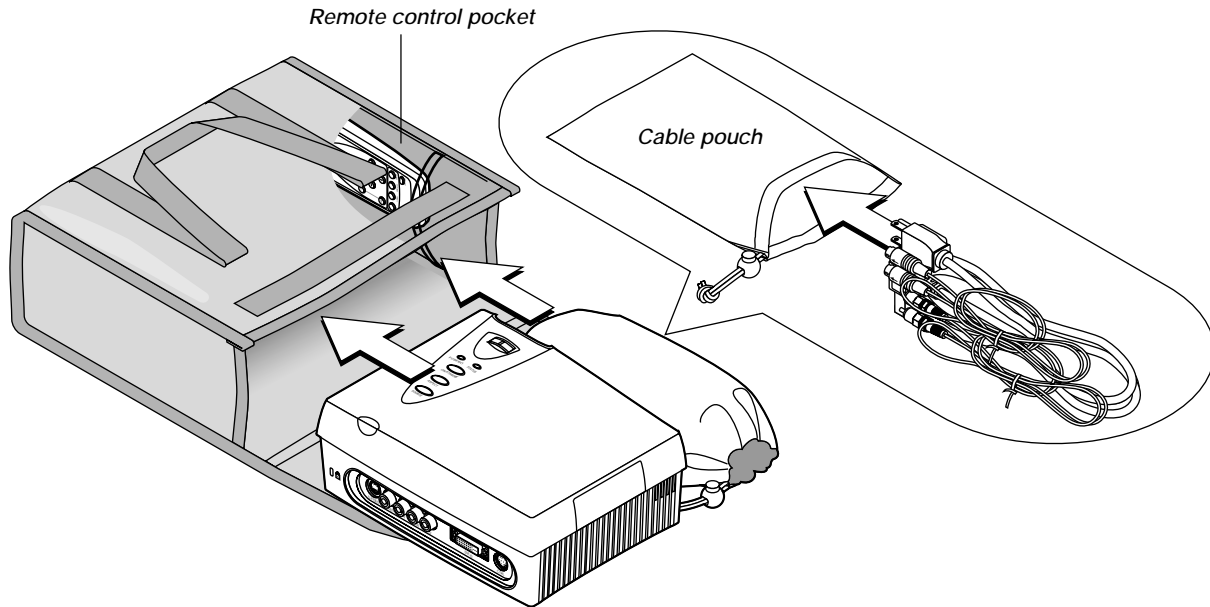

Attaching the Supplied Adjusters

The supplied adjusters are required for vertical adjustment of the projector.

See → Page E-19 about "Using the Adjusters"

1. Remove a rubber pad of each front foot.

Note: The rubber pads are bonded. Being careful not to mar the plastic part of the front feet, remove the rubber pads.

2. After putting projections on the back of the supplied adjuster into depressions of the front feet, tighten the screws.

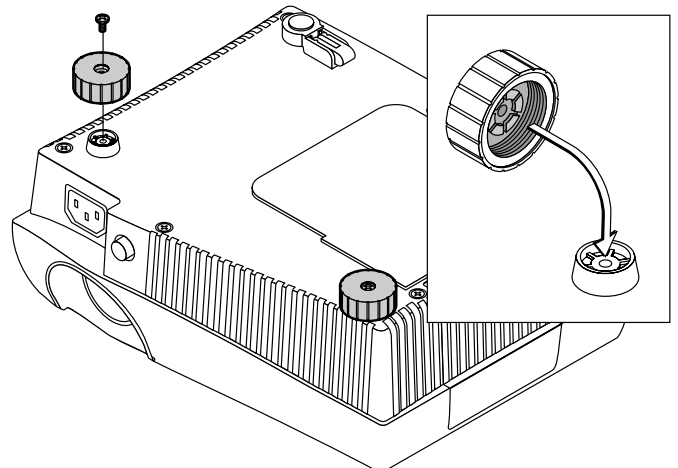
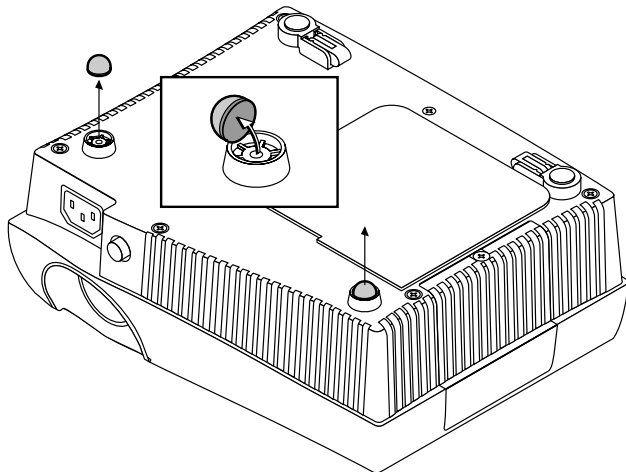

Attention!

- * Allow the main unit to cool sufficiently before placing it into the storage case. Storing the main unit soon after switching off the main power may cause damage to it.
- * Do not store in locations that will reach high or low temperatures. Doing so may adversely affect the electronic and mechanical components and could cause damage.
- * Do not place objects on top of the storage case when storing the equipment. When transporting, be careful not to bump or cause shocks to the projector.
- * Remove the batteries from the remote control when it is not going to be used for a long period.

Names of the Remote Control Parts

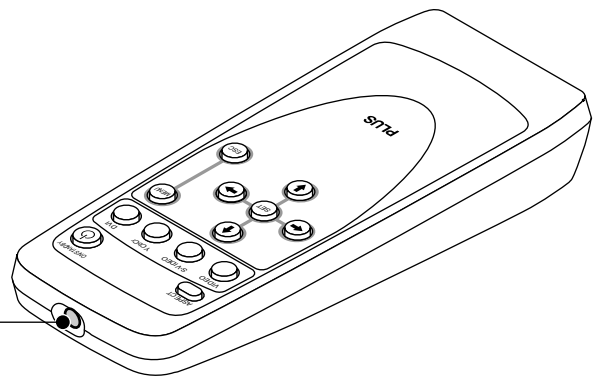

Remote control transmitter
The infrared signal is sent from this part.

ASPECT button
This button selects the vertical and horizontal ratio of the screen of the input video. → Page E-20

These buttons are used for the selection of the input.
For further information about input selection, see → Page E-20

VIDEO button
This switches the input to the VIDEO signal.

S-VIDEO button
This switches the input to the S-VIDEO signal.

YCbCr button
This switches the input to the Y Cb Cr signal.

DVI button
This switches the input to the DVI-D signal.

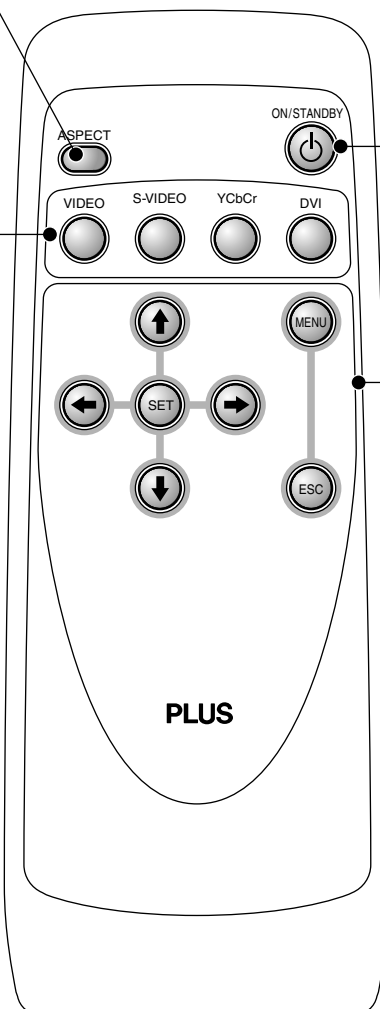

ON/STANDBY button
This button is used to switch ON the power and set the unit to the STANDBY mode. → Page E-18

These buttons are used for menu operations.
→ Page E-24 "Using the On-Screen Menu"

MENU button
This is used in the selection of the menu name when displaying the menu on the projection screen.

ESC button
This is used when closing the menu.

SET button
This is used to set the menu items.

Cursor buttons (← → ↑ ↓)
These are used in the selection of the menu name, item name, and contents.

Note: Handling of the Remote Control

- * Do not drop the remote control or handle it inappropriately.
- * Do not expose the remote control to water or other liquids. Should the remote control become wet, wipe it dry immediately.
- * Try to avoid use in hot and/or humid locations.
- * Remove the batteries from the remote control when it is not going to be used for a long period.
- * Some operations (such as menu operations) are available only through the use of the remote control and attention should be given to its careful use.

Preparing the Remote Control

Inserting the Batteries

When using the remote control for the first time, install the batteries that were supplied. When replacing batteries, purchase two of the same type of AA battery.

1 Press and at the same time lift the battery case cover at the rear of the remote control to remove it.

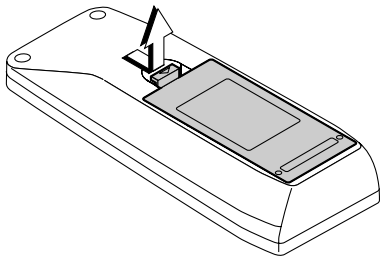

2 Follow the markings on the inside of the case and insert the batteries in the correct plus (+) and minus (-) directions.

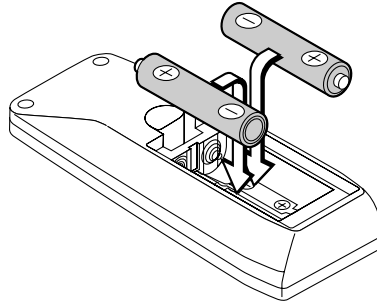

3 First insert the tabs of the battery case cover, then press it closed.

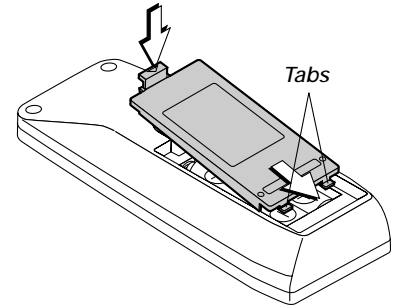

Remote Control Range

Point the remote control toward the remote control sensor located at the rear of the main unit and operate. The range over which the main unit will receive the remote control signal is roughly as follows: within 30° above and 30° below a line perpendicular with respect to the sensor and within 50° to the left and 50° to the right. The transmission range is about 7 m / 23.0 feet.

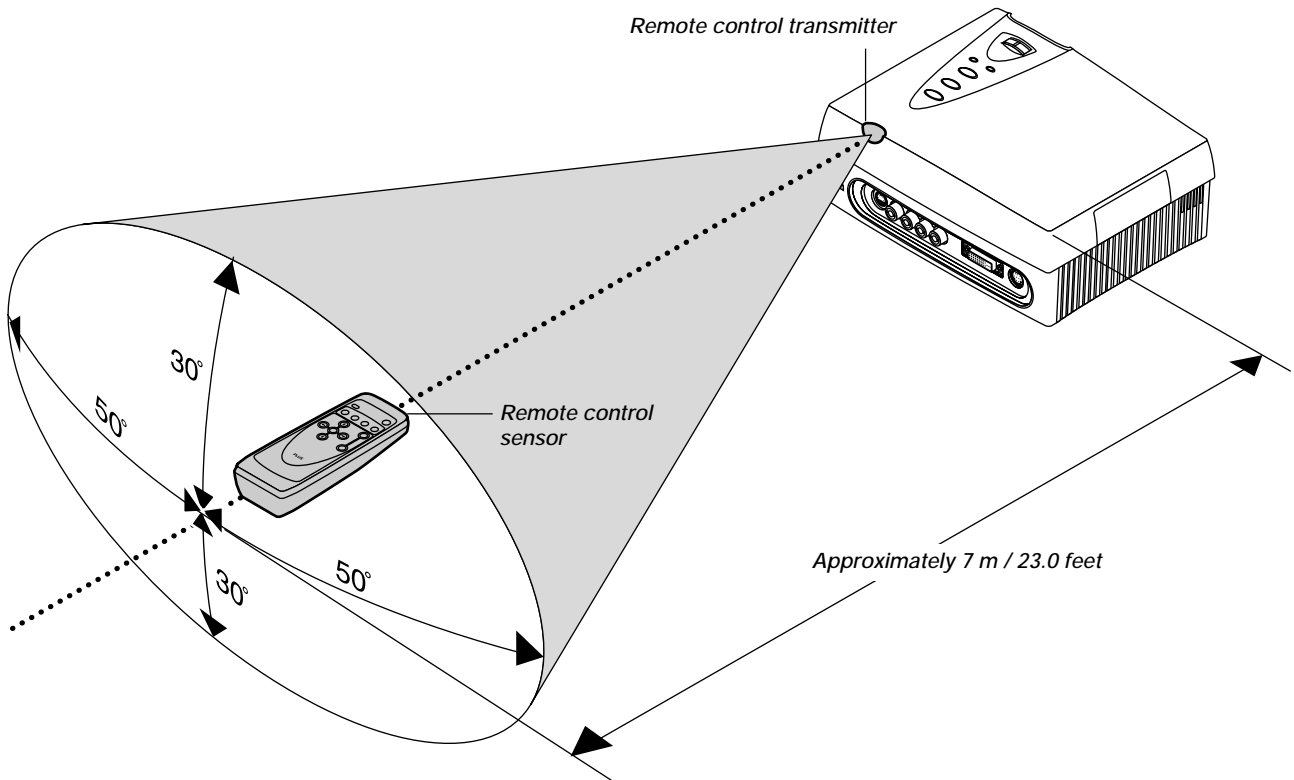

Note:

- * Exposure of the main unit's remote control sensor or the remote control transmitter to bright light or the obstruction of the signal by an obstacle located in the pathway may prevent operation.
- * The remote control will not function when the batteries are exhausted.

The Procedure Up to Projecting to the Screen

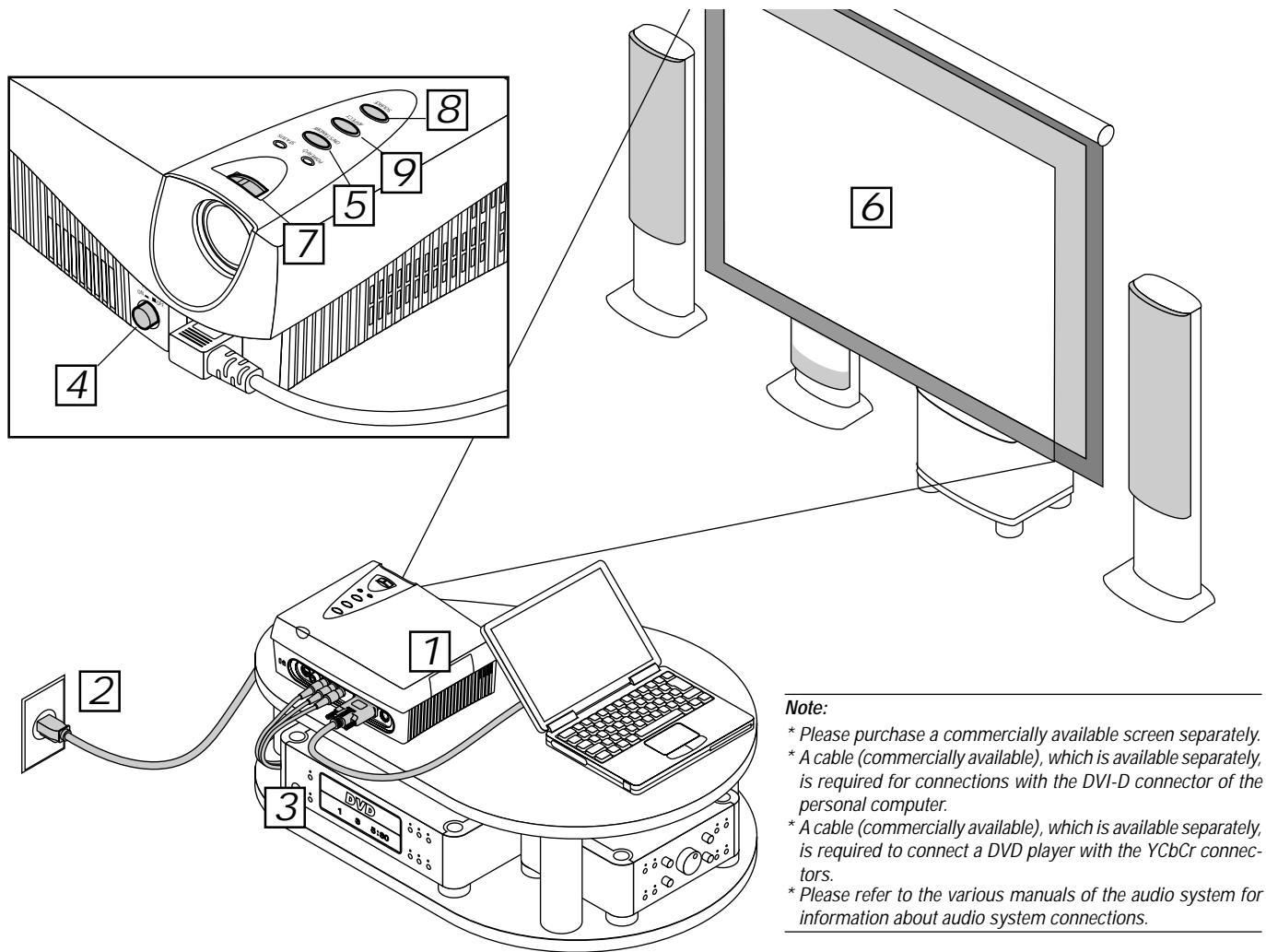

- 1 Position the projector** → Page E-13 "Projection Distance and Screen Size "
Determine the locations to place the screen and the projector.
- 2 Connecting the power cord** → Page E-14 "Power Cord Connections"
- 3 Connect the video equipment and personal computer**
Connect your equipment to the projector.
→ Page E-15 "Connections with VIDEO and S-VIDEO Connectors"
→ Page E-16 "Connections with Y, Cb, and Cr Connectors (COMPONENT)"
→ Page E-17 "Connections with DVI-D Connector"
- 4 Switching on the main power** → Page E-18 "Turning ON or OFF Main Power"
- 5 Switching on the power** → Page E-18 "Turning ON or OFF Power"
- 6 Properly adjust the projection image to the screen** → Page E-19 "Projection Screen Position Adjustment"
- 7 Focusing** → Page E-19 "Focus Adjustment"
- 8 Selecting input equipment** → Page E-20, 23 "Input Selection"
- 9 Selecting the vertical and horizontal aspect of the picture (i.e., the ratio of screen width and height)**
→ Page E-20, 23 "Selection of Aspect Ratio (i.e., Ratio of Screen Width to Screen Height)"

Placement Guide

Use this information as a guide to find the rough screen size when the projector is placed at a certain location, or to find out the approximate size of a screen that will be required.

The projection distance over which focussing is adjustable is 1.2 m (3.9 feet) to 6.9 m (22.6 feet) from the Lens surface of the main unit. The projector should be placed within this range.

1 Projection Distance and Screen Size

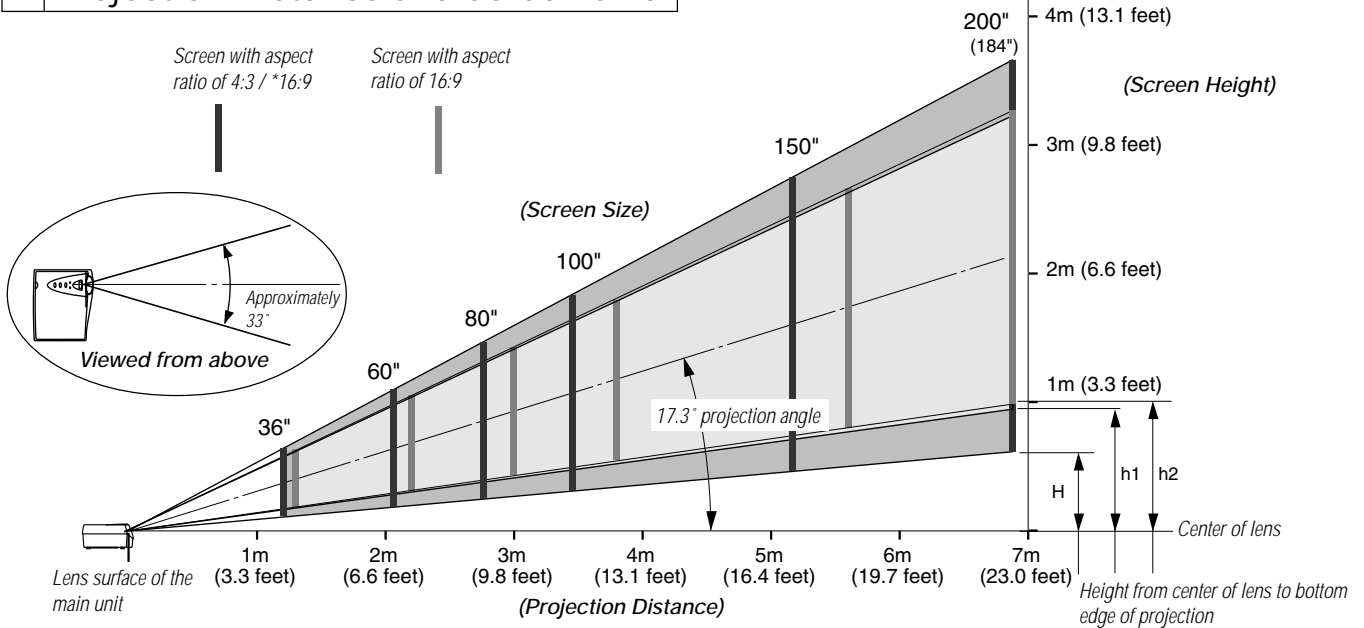

Screen Size (inch)	Width × Height (inch)	Projection Distance (feet)	Height (H)		
			H(inch)	h1(inch)	h2(inch)
36" (4:3)	28.8 × 21.6	3.9	3.9	—	—
* 36" (16:9)	31.3 × 17.6	4.3	—	7.2	—
36" (16:9)	31.3 × 17.6	4.3	—	—	7.2
60" (4:3)	48.0 × 36.0	6.9 ☆6.2	7.8	—	—
* 60" (16:9)	52.2 × 29.3	6.9	—	11.3	—
60" (16:9)	52.2 × 29.3	7.2	—	—	12.3
80" (4:3)	64.0 × 48.0	9.2 ☆8.5	10.4	—	—
* 80" (16:9)	69.6 × 39.1	9.2	—	15.1	—
80" (16:9)	69.6 × 39.1	9.8	—	—	17.2
100" (4:3)	80.0 × 60.0	11.5 ☆10.5	12.9	—	—
*100" (16:9)	87.0 × 48.9	11.5	—	18.8	—
100" (16:9)	87.0 × 48.9	12.5	—	—	22.2
150" (4:3)	120.0 × 90.0	17.1 ☆16.1	18.8	—	—
*150" (16:9)	130.4 × 73.4	17.4	—	28.3	—
150" (16:9)	130.4 × 73.4	18.4	—	—	32
200" (4:3)	160.0 × 120.0	22.6	24.6	—	—

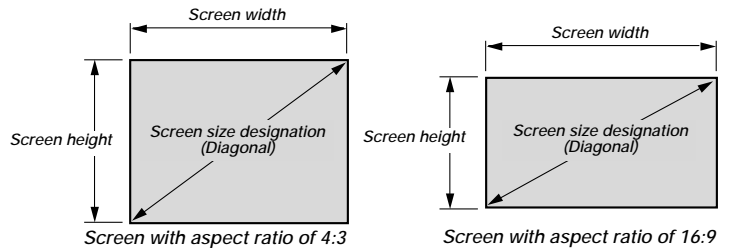

Screen Size (inch)	Width × Height (cm)	Projection Distance (m)	Height (H)		
			H(cm)	h1(cm)	h2(cm)
36" (4:3)	73.2 × 54.9	1.2	10	—	—
* 36" (16:9)	79.5 × 44.7	1.3	—	18.2	—
36" (16:9)	79.5 × 44.7	1.3	—	—	18.2
60" (4:3)	121.9 × 91.4	2.1 ☆1.9	19.7	—	—
* 60" (16:9)	132.5 × 74.5	2.1	—	28.8	—
60" (16:9)	132.5 × 74.5	2.2	—	—	31.3
80" (4:3)	162.6 × 121.9	2.8 ☆2.6	26.3	—	—
* 80" (16:9)	176.7 × 99.4	2.8	—	38.4	—
80" (16:9)	176.7 × 99.4	3.0	—	—	43.7
100" (4:3)	203.2 × 152.4	3.5 ☆3.2	32.8	—	—
*100" (16:9)	220.9 × 124.2	3.5	—	47.8	—
100" (16:9)	220.9 × 124.2	3.8	—	—	56.3
150" (4:3)	304.8 × 228.6	5.2 ☆4.9	47.7	—	—
*150" (16:9)	331.3 × 186.4	5.3	—	71.9	—
150" (16:9)	331.3 × 186.4	5.6	—	—	81.2
200" (4:3)	406.4 × 304.8	6.9	62.5	—	—

Note:

- * Projection distances marked with a ☆ in the table are a guide to the distance when an image of 16:9 aspect ratio (i.e., output size 848 × 480) is projected to fill a screen width of 4:3 aspect ratio.
- * Determine the screen size after checking the height and width of the room in which the screen will be installed as well as checking that there are no obstacles located in the path between the lens and the screen.
- * The larger the screen size becomes, the darker the image will be. Placing the projector to the rear of the screen to project the image will require the use of a translucent type screen.
- * The height from the feet of the main unit to the center of the lens is 72 mm (2.8 inch).
- * The projection table is based on an aspect of 4:3 (i.e., the ratio of screen width to height).
- * There is a tolerance of ±5% due to design values.

This projector uses an output size of 848 × 480 pixels for home theater applications and enables the projection of a high definition 16:9 aspect ratio. The 16:9 aspect ratios marked with a [*] in the above table are values with an output size of 848 × 480.

When establishing a fixed installation, please exercise care since the projection distance will be shorter than that of the normal 16:9 aspect ratio (800 × 450 output size).

Note that when an installation has been established to project a full screen at this setting, other input screens will be projected smaller than the screen size.

Note:

- * Do not install in location that will reach high or low temperatures. [Operation temperature: within 5°C (41°F) to 35°C (95°F)]
- * To raise the projection screen position, place the unit on a stable and strong support.
- * Bright light that enters the remote control sensor may prevent proper remote control operation.
- * Make efforts to ensure that sunlight or room illumination does not strike the screen. The more such extraneous light is shielded, the higher the contrast and more attractive the image that will be obtained.

Power Cord Connections

2 Power Cord Connections

Use the supplied power cord to connect the power connector of the main unit with the power outlet.

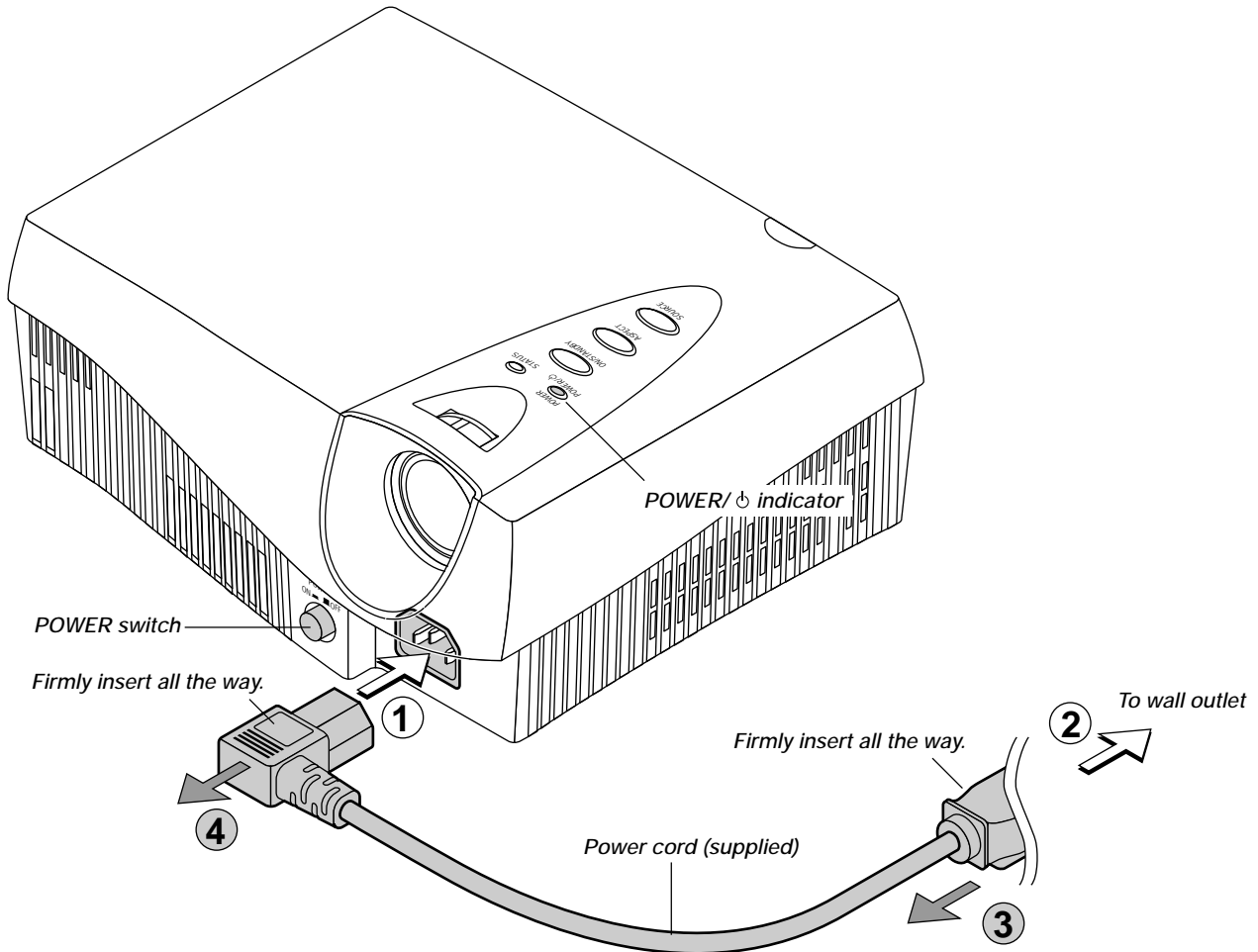

Before using the projector, first connect ① and then ②; after using, unplug ③ and then ④.

Attention!

For pluggable equipment, install the projector as near to the power outlet socket that is easily accessible.

Do not switch off the main power or disconnect the power cord unless the POWER/ⓘ indicator is lit orange. Doing so could shorten the life of the lamp or possibly cause the unit to malfunction.

When the unit is set to off (and the LED is not lit) using the menu [Setup] → [LED] items, the indicator flashes green for 1 minute, then goes off. Likewise, at this time the main power should not be switched off and the power cord should not be disconnected.

Connecting Video Equipment and Personal Computers

By connecting this unit with video equipment and using a DVD player or other source in combination with an audio/video amplifier and speaker system will allow you to enjoy convincing home theater. Connecting the unit to a personal computer will permit presentation data to be projected as a large screen display in conferences and lectures.

3 Connections with VIDEO and S-VIDEO Connectors

These are connections made with equipment that is equipped with a video output connector or an S-video output connector such as video decks, DVD players, laser disc players, TV tuners, etc. Connect such equipment to the VIDEO or S-VIDEO connector of this projector.

Connections with the Video Output Connector

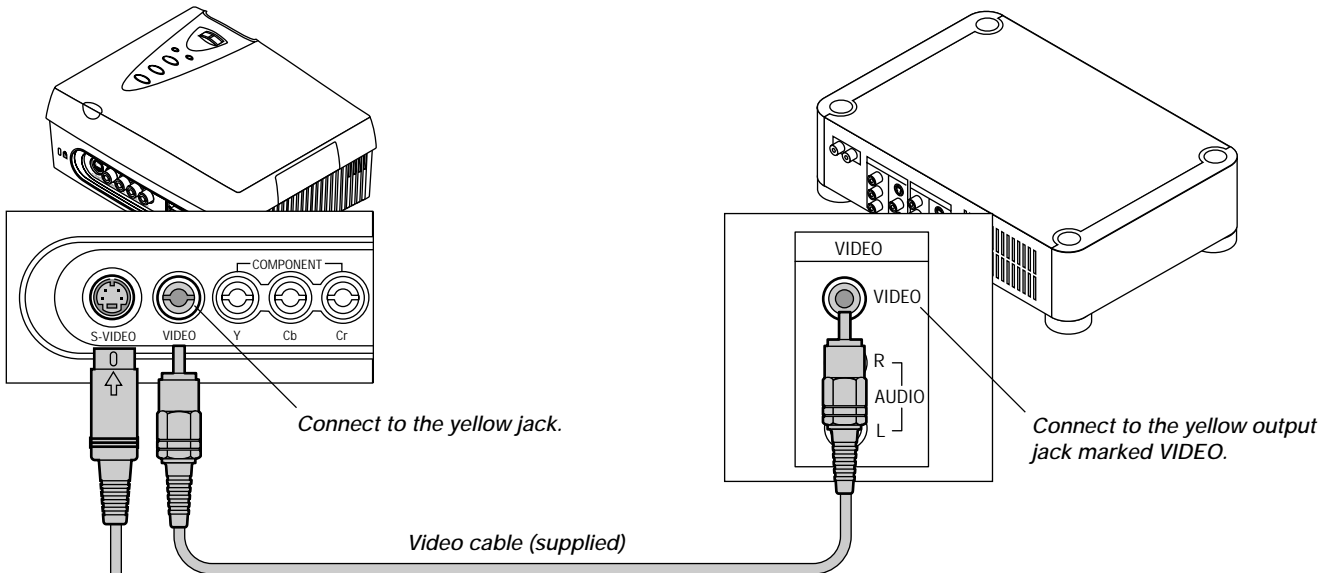

Connections with the S-VIDEO Output Connector

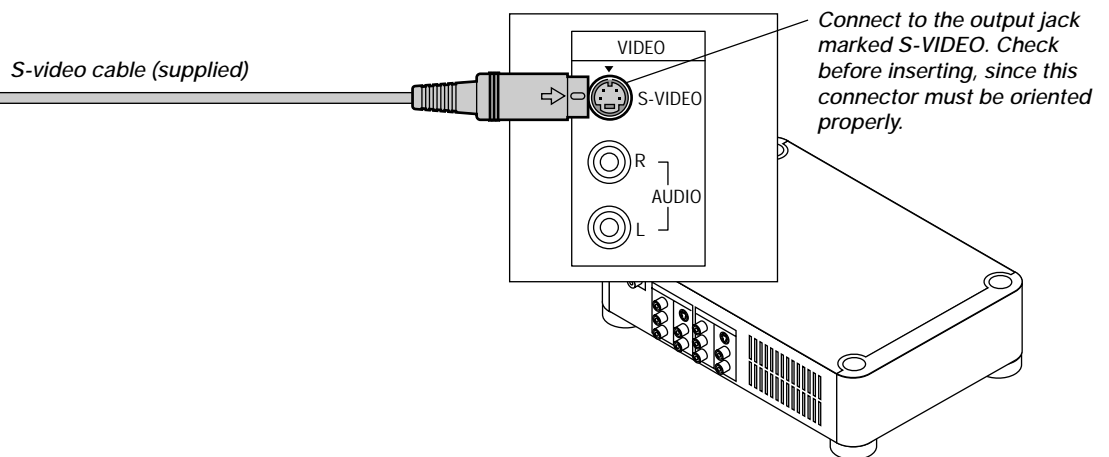

Note:

- * Connection can be made with the S1 video and S2 video output connectors, but the control signals will not be operable in the projector depending on video equipment.
- * Please refer to the various manuals for information about video equipment and audio/video amplifier and speaker system connections.

Attention!

Before making connections, check that the main power supply is switched off for the projector and the equipment that is to be connected.

3 Connections with YCbCr Connectors

These connections are made with equipment such as a DVD player that is equipped with the YCbCr output jacks of the component signals.

Make connections to the Y, Cb, and Cr jacks (COMPONENT) of the main unit.

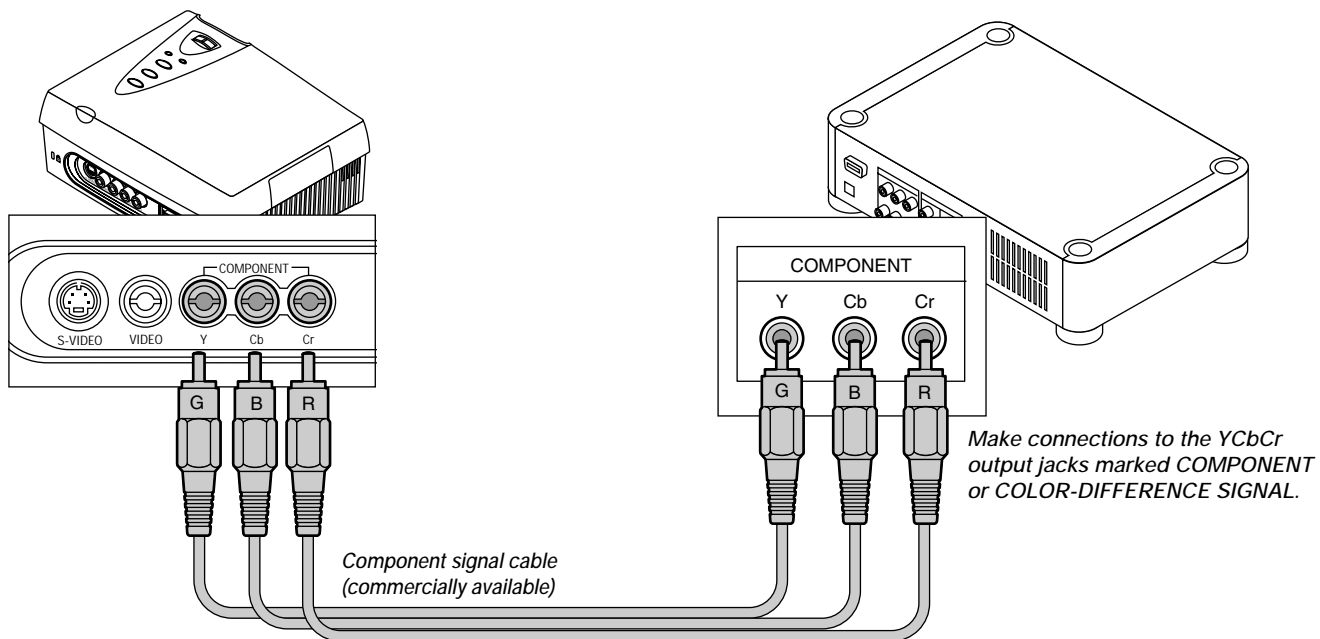

Component signal cable (commercially available)

The component signal jacks and the cables are classified by color. Make proper connections by matching the same color of plugs and jacks.

Note: Please refer to the various manuals for information about video equipment and audio/video amplifier and speaker system connections.

3 Connection with DVI-D Connector

This connection is made with personal computers that are equipped with a display output DVI-D connector. Make the connection with the DVI-D connector of the main unit.

Check the following before making connections.

- * The resolution through this unit is S-VGA 800 x 600 dots. VGA is enlarged and displayed and XGA is compressed and displayed. Input of resolutions higher than S-XGA will not be displayed. Such resolutions should be converted to a displayable resolution at the personal computer side. Check with the following "Table of Supported Frequencies".
- * The setting method of the personal computer will vary depending on your personal computer. For information, read the instruction manual for your personal computer, read the on-line help, or contact the manufacturer of your personal computer.

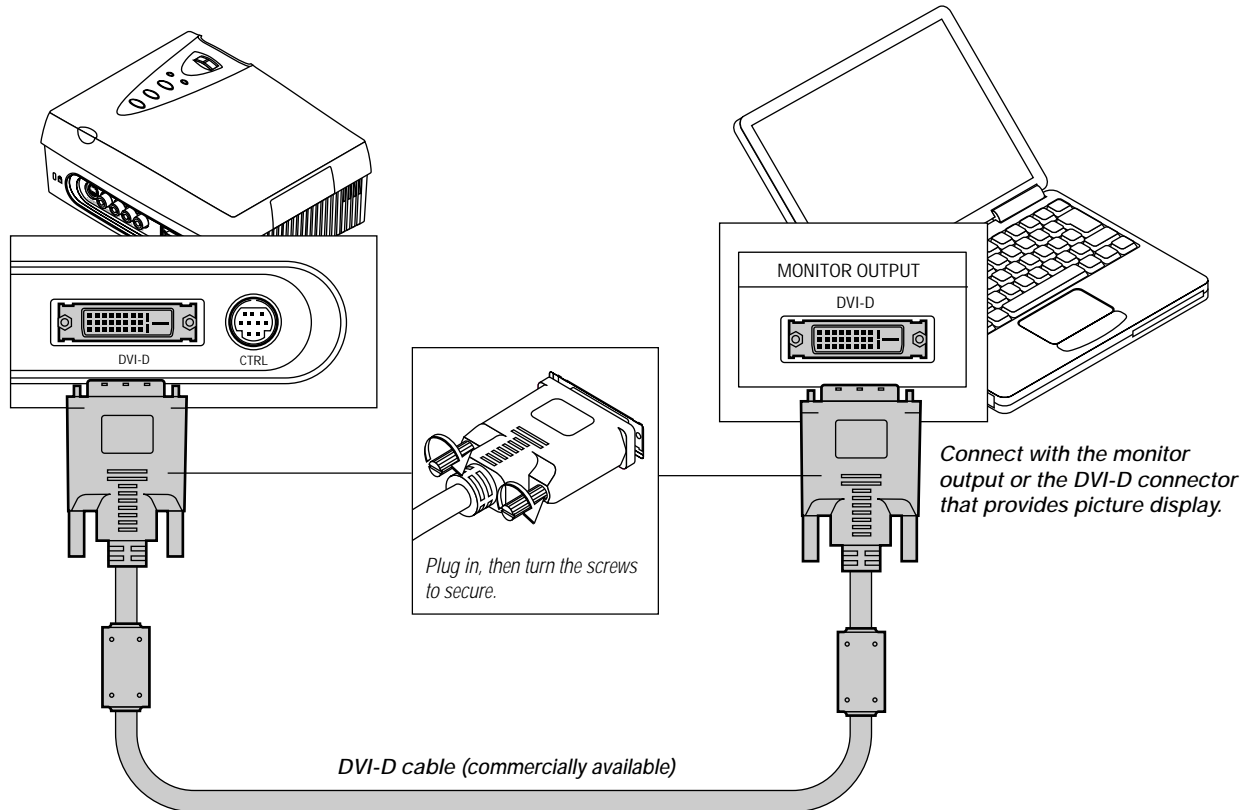

Table of Supported Frequencies

	Resolution	V. Frequency (Hz)	H. Frequency (kHz)	Display
VGA	640X480	59.940	31.469	Through/Expanded
S-VGA	800X600	60.317	35.156	Through
XGA	1024X768	60.004	48.363	Through/Compressed

* Some personal computers have different resolutions from the above, and do not support the above resolutions and frequencies.

Note:

- * This unit uses a digital interface 24-pin DVI-D connector. Digital signal TMDS (Transition Minimized Differential Signalling) of the DVI (Digital Visual Interface) standard is used. (Analog RGB signals cannot be input.)
- * Personal computers that are not equipped with a DVI-D connector require a digital graphics board furnished with a DVI-D connector.
- * Before making connections, turn off the main power to the projector and all the connected equipment.
- * When projection will be with a notebook computer connected, knowledge will be required for the cable connection and notebook computer startup procedure as well as the operation that follows startup. Please consult the instruction manual of your notebook computer or the on-line help.

Turning ON or OFF Main Power

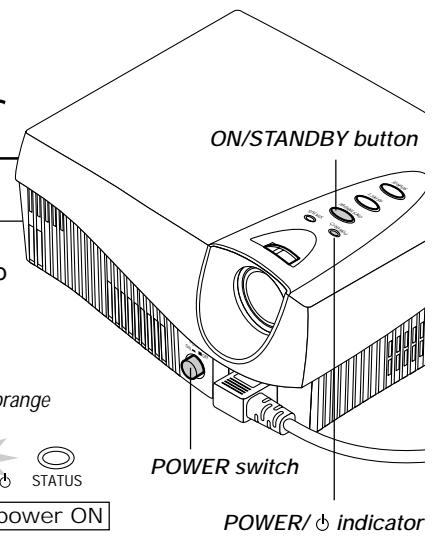

4 Turning ON or OFF Main Power

Before turning the main power, check that the power is switched off the equipment that is to be connected and the connection is finished.

To turn on the main power:
Press the POWER switch down until it is in the depressed position.

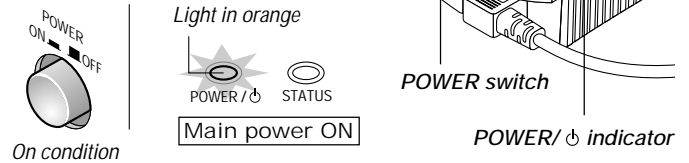

To turn off the main power:
Press the POWER switch until it is in the protruded position.

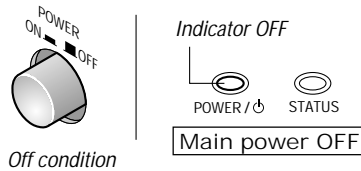

5 Turning ON or OFF Power

The ON/STANDBY buttons of the main unit and the remote control have the same function. A description using the main unit button is provided here.

To turn on the power:
Press the ON/STANDBY button for about 2 seconds. The projection screen will brighten in about 40 seconds.

Note: When the unit is set to off (and the LED is not lit) using the menu [Setup] → [LED] items, the indicator flashes green for 60 seconds, then goes off.

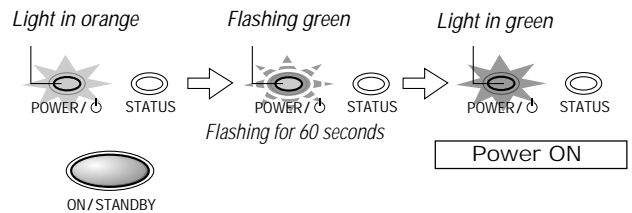

Setting standby mode
Press and hold down the ON/STANDBY button for about 2 seconds.

To switch on the power again, leave at least 60 seconds before doing so.

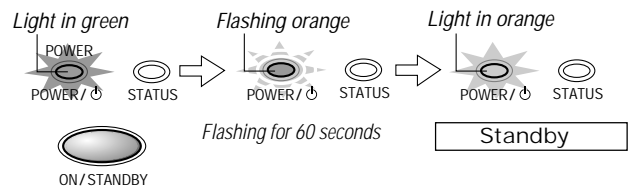

Attention!

- Do not switch off the main power or disconnect the power cord unless the POWER/STATUS indicator is lit orange. Doing so could shorten the life of the lamp or possibly cause the unit to malfunction. When the unit is set to ON (and the LED is not lit) using the menu [Setup] → [LED] items, the indicator flashes green for 1 minute, then goes off. Likewise, at this time the main power should not be switched off.
- To save power, switch off the main power when not in use. When the main unit or remote control ON/STANDBY button is used to set the projector to the standby mode (POWER/STATUS indicator is lit orange), the cooling fan continues to operate.

Note:

- * When a signal is not being input while projecting onto the projection screen, "No Signal" is displayed to indicate the condition. The background color of the screen will be blue at this time. The background color can be changed to black by via [Setup] → [Background] of the menu. → Page E-34 "Background Color Settings"
- * When the power is switched on, the input selection and aspect selection conditions will be the same as the conditions that existed when the power was switched off.
- * Adjustments and setting values that were made via menu operations will be stored even when the main power has been switched off or the power cord has been disconnected.

When the power won't switch on

- * When the internal temperature is abnormally high, the power will not be switched on to protect the equipment. Wait for a while and then try switching on the power again.
- * Should the STATUS indicator be lit or flashing, please see "When the STATUS Indicator Is Lit/Flashing" on Page E-39.

Adjustment of the Projection Screen

Operations include the adjustment of the image position that is projected to the screen and the adjustment of the focus as well as the input selection and the selection of the aspect ratio.

Perform these operations with the power of the connected equipment switched on and the video signal input to the projector.

6 Projection Screen Position Adjustment

1 Adjust the projection image to the screen

- (1) If the image is shifted to the left or right, move the main unit horizontally. (Align the center of the screen and the center of the lens of the main unit.)
- (2) If the image is shifted vertically, move the image up or down with the adjuster.
- (3) A projection image such as that illustrated in the diagram is the result of the projector not being perpendicular to the screen. Set the projector so that it is pointing straight toward the screen.
- (4) If the image shows keystone distortion, adjust using menu operations. → Page E-33 "Adjustment of Keystone Distortion"

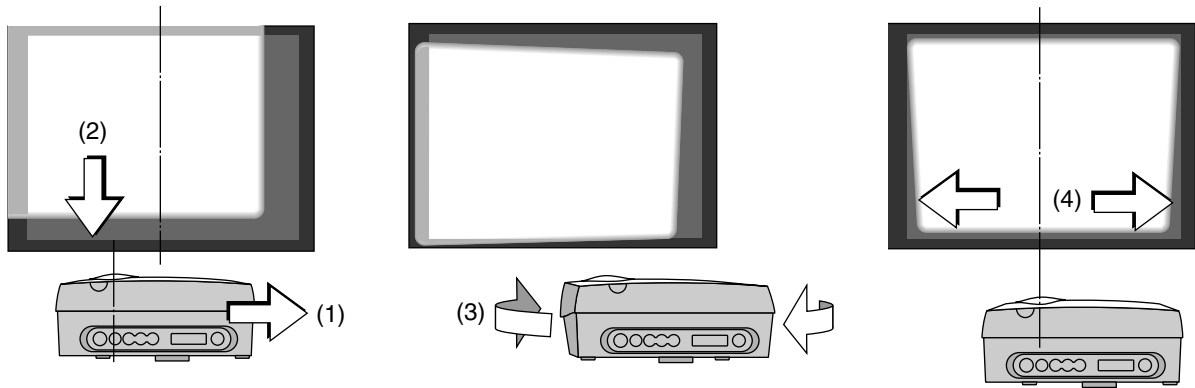

Using the Adjusters

To lower the projection position:
Raise the rear adjusters up

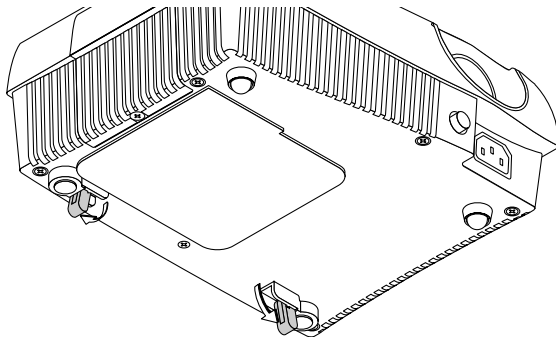

To raise the projection position:

Attach the supplied two adjusters to the front feet. See page E-9 "Attaching the Supplied Adjusters". After folding the rear adjusters, rotate the right/left front adjuster to fine-adjust the height. (Adjustable range: 0 to 5 mm/ 0 to 0.2 inch)

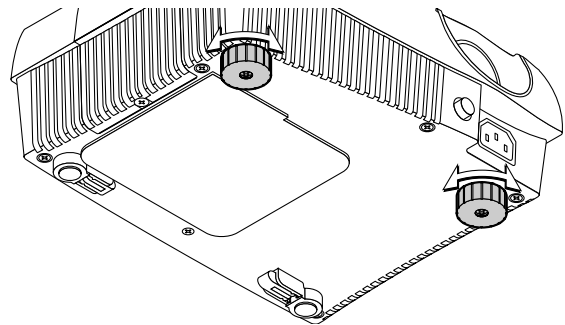

7 Focus Adjustment

2 Turn the FOCUS ring and adjust the focus.

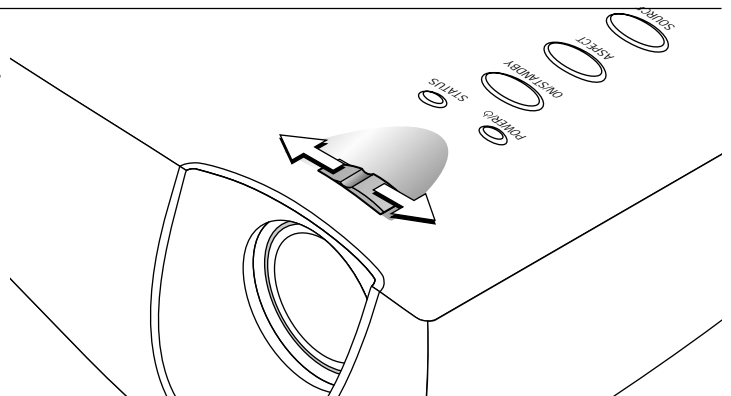

8 Input Selection

3 Press the SOURCE button and select the desired connector .

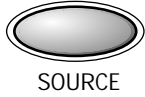

A press of the SOURCE button will display the currently selected input selection. Each press of the button moves the selection one step in the sequence: VIDEO → S-VIDEO → YCbCr → DVI

The selection will not change while "Now Searching" is displayed. The display will remain for a while before disappearing. To change the duration of the display, see → Page E-35 "On-Screen Display Duration Setting."

Input selection display

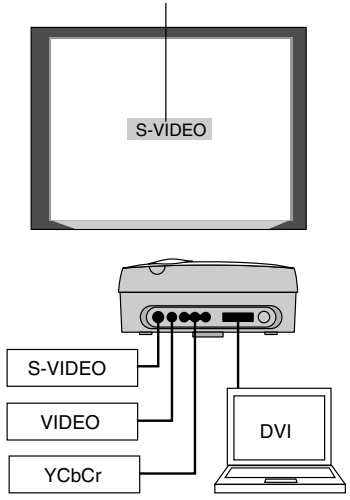

Note:

- * The remote control provides direct selection from the VIDEO button, S-VIDEO button, YCbCr button, and DVI button.
 - * When the power is switched on, the input selection conditions that existed when the power was switched off will be in effect.
 - * When a signal is not input to the selected connector, "No Signal" is displayed.
 - * When DVI is selected and "DVI No Signal" is displayed, check with [Information] on the menu.
- Page E-37 "Viewing the Lamp Timer/ Resolution and Frequency"
When the frequency is displayed as "0 kHz, 0 Hz," there is no signal from the personal computer. See → Page E-17 "Connection with DVI-D Connectors" and → Page E-17 "Table of Supported Frequencies."

9 Selection of Aspect Ratio (i.e., Ratio of Screen Width to Screen Height)

4 Press the ASPECT button and select the desired aspect ratio.

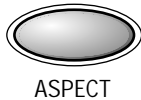

A press of the button will display the aspect selection display.

The aspect ratio is the ratio of the width and height of the screen.

Aspect Selection Display

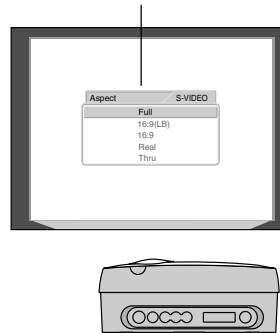

Note:

- * The aspect ratio selection display will not appear unless a signal is input. Play the video of the equipment.
- * Match the aspect ratio of the image of the connected equipment with the aspect ratio of the projected image of this unit, or adjust the image of a 16:9 aspect to the desired format.
- * When the aspect ratio differs, a circle, for example, will be projected as an ellipse.
- * The selected aspect ratio for each input is stored.

[VIDEO, S-VIDEO, and YCbCr Input Selection]

Aspect	S-VIDEO
Full	
16:9(LB)	
16:9	
Real	
Thru	

[DVI Input Selection]

Aspect	DVI
Full	
Auto	
16:9	
Thru	

Cursor: Displays the currently selected contents position.

Press the ASPECT button during the appearance of the aspect selection display and make the selection.

Each press of the button moves the cursor and switches the aspect ratio. A diagram of the a sample image with different aspect ratios is carried on the next page. The aspect selection display will remain for a while before disappearing. To change the duration of the display, see → Page E-35 "On-Screen Display Duration Setting."

Note:

- * For information about operation with the remote control, see → Page E-22 "Operation with the Remote Control"
- * To adjust or set the brightness, picture, or other matters, display the menu on the projection screen and perform the operation. → Page E-24 "Using the On-Screen Menu"

This completes the projection screen adjustments.

Input Screen and Aspect Ratio Selection Screen

	<i>Projection image with Through selection</i>		<i>Projection image when selected</i>	
<p>Select Full The image is projected to fill the entire screen. Aspect 16:9 screens will be longer than wide.</p>		➔		
<p>Select Auto (only with DVI selection) While maintaining the aspect ratio of the personal computer, the image is enlarged or reduced so that no parts protrude beyond the screen and the image is projected to fill the screen. Aspect 16:9 screens will be black at the top and bottom.</p>		➔		
<p>Select 16:9 (LB) (VIDEO, S-VIDEO, and YcbCr only) The image of long sideways movie material is projected to fill the entire screen without the top and bottom black portions. This maintains a letterbox image aspect ratio and projects it on a 16:9 screen. This will make the image quality better than "Full".</p>		➔		The top and bottom black portions are cut. Subtitles are also cut.
<p>Select 16:9 This returns the squeezed screen to a 16:9 screen and projects it. The output size becomes 848 x 480.</p>		➔		The output size becomes 848 x 480.
<p>Select Real (VIDEO, S-VIDEO, and YcbCr only) This maintains a video image aspect ratio of 4:3 and projects it.</p>		➔		

Select Thru

This projects the input image as is. Video images may have a different aspect ratio.

[Display Examples]



Operation with the Remote Control

Point the remote control toward the remote control sensor of the main unit and operate.

ASPECT button

This button selects the vertical and horizontal ratio of the screen of the input video.

These buttons are used for the selection of the input signal.

For further information about input selection.

VIDEO button

This switches the input to the VIDEO signal.

S-VIDEO button

This switches the input to the S-VIDEO signal.

YCbCr button

This switches the input to the Y Cb Cr signal.

DVI button

This switches the input to the DVI-D signal.

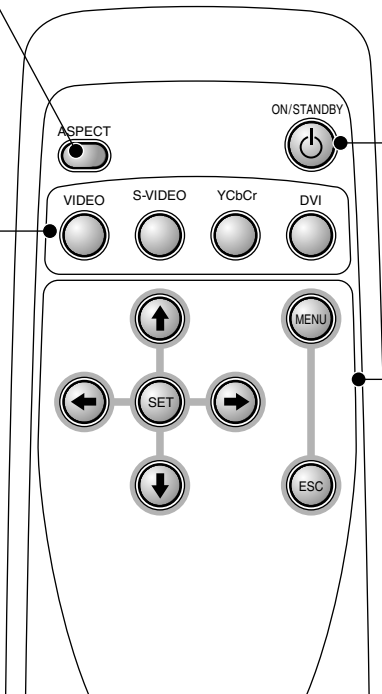

ON/STANDBY button

This button is used to switch ON the power and set the unit to the STANDBY mode.

These buttons are used for menu operations.

→ Page E-24 "Using the On-Screen Menu"

MENU button

This is used in the selection of the menu name when displaying the menu on the projection screen.

ESC button

This is used when closing the menu.

SET button

This is used to set the menu items.

Cursor buttons (← → ↑ ↓)

These are used in the selection of the menu name, item name, and contents.

Turning ON Power/STANDBY

Press the POWER button of the main unit and turn on the main power.

To turn on the power:

Check that the POWER/  indicator of the main unit is lit orange.

Press the ON/STANDBY button for about 2 seconds.

ON/STANDBY



The power will be switched on, the indicator will flash green (for one minute) and then the indicator will be lit green. The projection screen will brighten in about 40 seconds.

Setting standby mode:

Press and hold down the ON/STANDBY button for about 2 seconds.

The indicator will flash orange (for 60 seconds) and then be lit orange.

Light in green

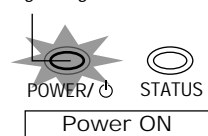

Note: To save electrical power when not using the unit, switch off the main power. When doing so, wait until the flashing orange indicator is lit steadily.

Light in orange

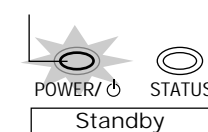

Attention!

When switching off the main power or disconnecting the power cord

First press ON/STANDBY button of the remote control or the main unit to set the standby mode (in which the indicator will be lit orange) and then switch off the main power. If the main power of the main unit is switched off without setting the standby mode, this could shorten the life of the lamp or possibly cause damage due to the heat of the lamp.

Input Selection

Press the desired input selection button.

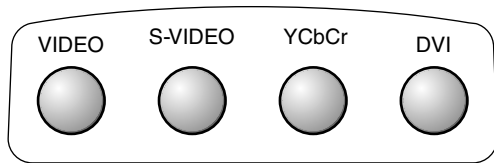

A press of the button will result in the unit switching to the desired input connector.

The display will remain on for a while before disappearing. To change the duration of the display, see → Page E-35 "On-Screen Display Duration Setting."

Input selection display

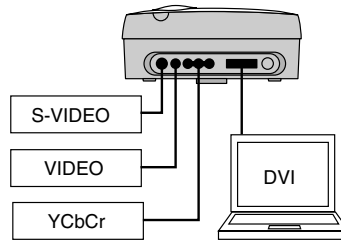
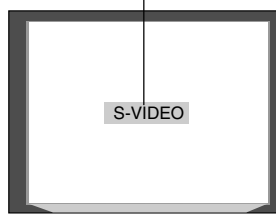

Note:

- * When the power is switched on, the input selection conditions that existed when the power was switched off will be in effect.
- * When a signal is not input to the selected connector, "No Signal" is displayed.
- * When DVI is selected and "DVI No Signal" is displayed, check with [Info.] on the menu. → Page E-37 "Viewing the Lamp Timer/Resolution and Frequency" When the frequency is displayed as "0 kHz, 0 Hz," there is no signal from the personal computer. See → Page E-17 "Connection with DVI-D Connectors" and → Page E-17 "Table of Supported Frequencies."

Selection of Aspect Ratio (i.e., Ratio of Screen Width to Screen Height)

Press the ASPECT button and select the desired aspect ratio .



A press of the button will display the aspect selection display.

The aspect ratio is the ratio of the width and height of the screen.

Aspect Selection Display

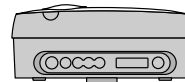
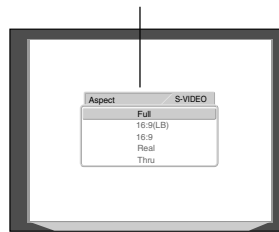

Note:

- * The aspect ratio selection display will not appear unless a signal is input. Play the video of the equipment.
- * Match the aspect ratio of the image of the connected equipment with the aspect ratio of the projected image of this unit, or adjust the image of a 16:9 aspect to the desired format.
- * When the aspect ratio differs, a circle, for example, will be projected as an ellipse.
- * The selected aspect ratio for each input is stored.

[VIDEO, S-VIDEO, and YCbCr Input Selection]

Aspect	S-VIDEO
Full	
16:9(LB)	
16:9	
Real	
Thru	

[DVI Input Selection]

Aspect	DVI
Full	
Auto	
16:9	
Thru	

Cursor: Displays the currently selected contents position.

Press the ASPECT button while the aspect selection display is shown and make the selection.

Each press of the button moves the cursor and switches the aspect ratio.

Also the selection can be made with the cursor (↑↓) buttons.

A diagram of the a sample image with different aspect ratios is carried on the next page.

The aspect selection display will remain for a while before disappearing.

To change the duration of the display, see → Page E-35 "On-Screen Display Duration Setting."

Using the On-Screen Menu

Only menu operation methods will be described here.

Refer to this page should you need to clarify matters during menu operations.

See the various pages for information about menu functions and performing adjustments and settings.

To perform adjustments and settings, the video is projected and adjustments are made to the optimum condition.

The remote control should be pointed toward the remote control sensor of the projector and operated.

To return the various items that have been changed with the menu to their default values (i.e., the condition that existed at the time of purchase), see → Page E-37 "Returning to Standard Settings."

Names and functions of the buttons used in menu operations

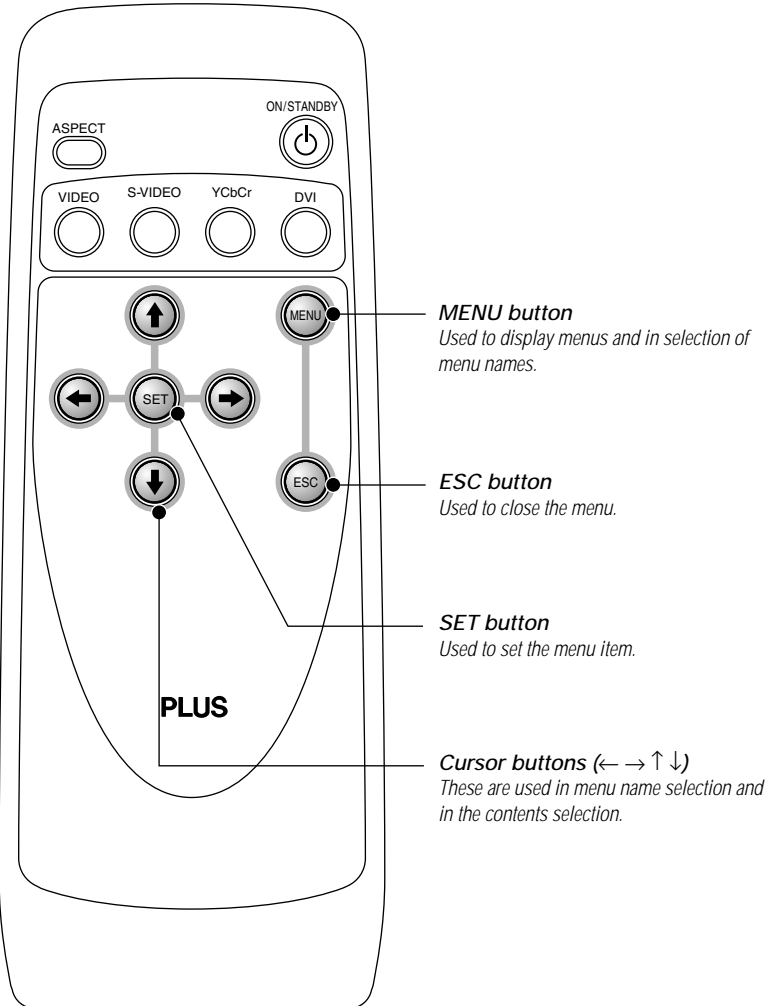

Names and functions of the menu screens

Menu names

These are the menu headings. When a menu is selected, there is a switch to the heading screen. The selected menu name appears in blue.

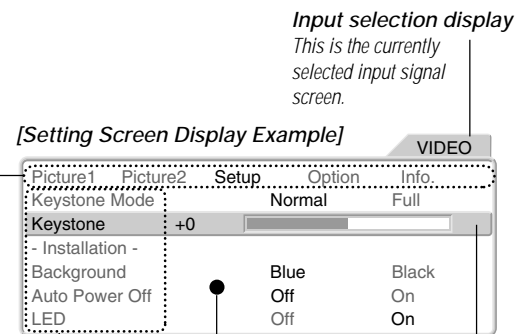

Selected contents
Select the desired contents. Selected characters appear in red.

Item name

This is the name of the adjustment or setting. The selected item name appears in navy blue. A press of the SET button at a location where only the item name is displayed results in a change to the selection contents screen. The contents will change for the item name depending on the input selection.

Cursor

The item at the cursor position can be adjusted or set. Move the cursor with the cursor buttons.

Note:

- * If a remote control operation is not performed in about 10 seconds (i.e., the initial setting time) from the time the menu is displayed, the menu will automatically close. → Page E-35 "On-Screen Display Duration Setting"
- * The display position of the menu can be changed. → Page E-35 "Moving the Menu Display Position"

Display of the Menu

1 Press the MENU button and display the menu.

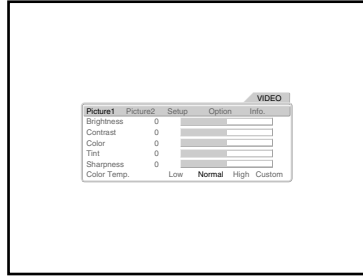

Selection of the Menu Name

2 Press the button again and select the menu name.
The selected menu name will appear in navy blue.

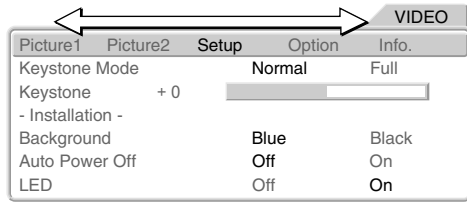

Each press of the MENU button switches the menu one step in the sequence of [Picture 1] → [Picture 2] → [Setup] → [Option] → [Info.]

Note:

- * The menu name will change also when the cursor (← →) button is pressed.
- * When using the cursor button to select the menu name, the cursor must be in the menu name column (at the very top) or else selection will not be possible.
- * When the cursor is not located at the menu name, the selected menu name will appear in blue.
- * For information about the contents list that is displayed in the menu, see → Page E-27 "Menu List."

Selection of the Item Name

3 Press the cursor button (↑↓) and select the item name.
Align the cursor with the desired item name. The selected item name will appear in deep blue.

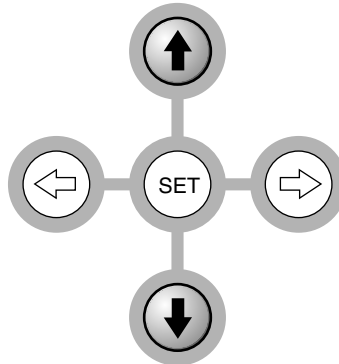
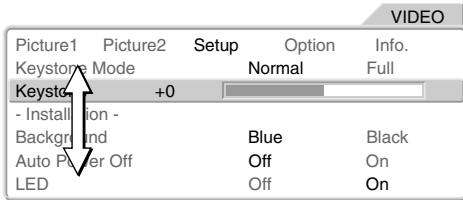

Note: When the cursor is not located at the menu name, the selected menu name will appear in blue.

Making Adjustments and Settings

4 Press the cursor button (← →) and make the adjustment (or selection).
Adjust (or select) to produce the best picture.

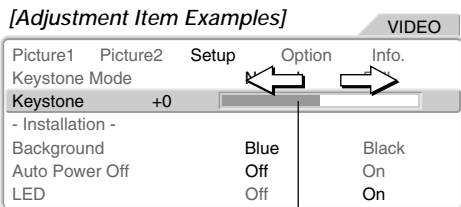

Adjustment bar

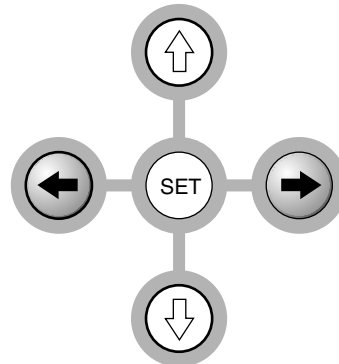

Note:

- * For adjustment items, adjustment values are indicated by the increase and decrease of the adjustment bar and the numerical value. Adjust for the optimum picture while viewing the image projected to the screen.
- * The selected characters will appear in red for items that select On, Off, and other titles.

(Continued on the next page)

Sub menu items

Items that display only an item name have a sub menu.

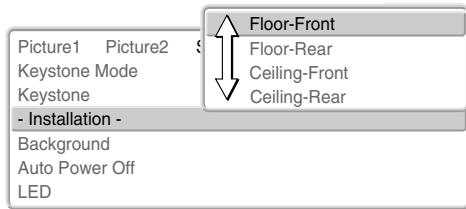
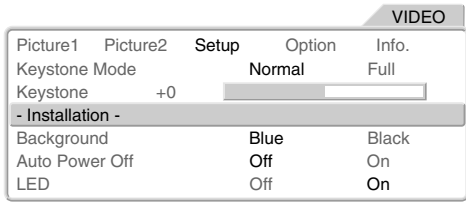

Press the SET button to display the sub menu.

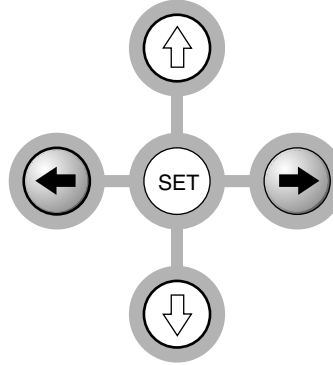

For setup, select with the cursor button (↑↓).

Note: The selection operation will differ for the sub menu depending on the item contents.

Note: A transition to item selection of the menu will not be possible while the sub menu is being displayed. To select the next item, press the ESC button, close the menu again, then perform the selection.

Exit

5 Press the ESC button and close the menu display.

The selected menu name will appear in navy blue.



Note:

- * Even without pressing the ESC button, waiting a while will result in the menu closing (when the display duration setting has elapsed).
- * The adjustment and setting values will be stored even when the power is switched off or the power cord is disconnected.

Menu List

This is a list of menu item names. See the reference page for information about the adjustment and setting method.
 The display contents of the item name will differ depending on the input selection.

Picture 1

[VIDEO, S-VIDEO, and YCbCr Input Selection] VIDEO

Picture1	Picture2	Setup	Option	Info.
Brightness	0	<input type="text"/>		
Contrast	0	<input type="text"/>		
Color	0	<input type="text"/>		
Tint	0	<input type="text"/>		
Sharpness	1	<input type="text"/>		
Color Temp.		Low	Normal	High Custom

"Adjusting the Picture" → Page E-29

"Adjusting the White Balance" → Page E-29

[DVI Input Selection] DVI

Picture1	Picture2	Setup	Option	Info.
Brightness	0	<input type="text"/>		
Contrast	0	<input type="text"/>		
Color Temp.		Low	Normal	High Custom

Picture 2

[VIDEO, S-VIDEO, and YCbCr Input Selection] VIDEO

Picture1	Picture2	Setup	Option	Info.
Video Filter	2	<input type="text"/>		
Zoom Filter	2	<input type="text"/>		
ProScan Mode		Video	Auto	
Gamma		Video	Film	Graphics Custom
Color System	Auto			

"Adjusting the Sharpness of the Video Image" → Page E-30

"Adjusting the Sharpness When Expanding/Compressing" → Page E-30

"ProScan Mode Settings" → Page E-30

"Gamma Settings" → Page E-31

"Video Signal Color System Settings" → Page E-32

[DVI Input Selection] DVI

Picture1	Picture2	Setup	Option	Info.
Zoom Filter	0	<input type="text"/>		
- Pan -				
Gamma		Video	Film	Graphics Custom

"Adjustment of Screen Display Position" → Page E-31

Setup

[Common Inputs] VIDEO

Picture1	Picture2	Setup	Option	Info.
Keystone Mode		Normal	Full	
Keystone	+0	<input type="text"/>		
- Installation -				
Background		Blue	Black	
Auto Power Off		Off	On	
LED		Off	On	

"Adjustment of Keystone Distortion" → Page E-33

"Screen Projection System Settings" → Page E-33

"Background Color Settings" → Page E-34

"Auto Standby Settings" → Page E-34

"LED Display Settings" → Page E-34

Option

- "On-Screen Display Language Settings" → Page E-35
- "Moving the Menu Display Position" → Page E-35
- "On-Screen Display Duration Adjustment" → Page E-35

[Common Inputs] VIDEO

Picture1	Picture2	Setup	Option	Info.
Language		En De Fr It Es Sv 中日		
- Menu Position -				
Duration	10 sec.			

Info.

- "Saving and Loading of Video Adjustments" → Page E-36
- "Returning to Standard Settings" → Page E-37
- "Resetting the Lamp Timer" → Page E-37

[VIDEO, S-VIDEO, and YCbCr Input Selection] VIDEO

Picture1	Picture2	Setup	Option	Info.
User Memory			Save	Load
- Default -				
- Lamp Timer Reset -				

----- Status: 100 .500
 Lamp Timer: 1 hrs (Total 1 hrs)

[DVI Input Selection] DVI

Picture1	Picture2	Setup	Option	Info.
- Default -				
- Lamp Timer Reset -				

- "Viewing the Lamp Timer/Resolution and Frequency" → Page E-37

----- Status: 100 .500
 Resolution: 800 X 600
 Frequency: H: 37.8KHz V: 60Hz
 Lamp Timer: 1 hrs (Total 1 hrs)

Video Adjustments [Picture 1]

These are picture-related adjustments.

For information about performing menu operations, see → Page E-24 "Using the On-Screen Menus."

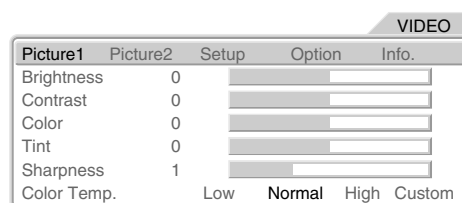

The [Color], [Tint], and [Sharpness] items will not be displayed when selecting the DVI input.

Preparation

- * Project the image.
- * Press the MENU button to display the menu, then select [Picture 1].

Brightness / Contrast / Color / Tint / Sharpness

Adjusting the Picture

The brightness, contrast, and other adjustments will differ depending on whether the room is bright or dark. Make adjustments to suit your preference.

Press the cursor button (↑↓) and align the cursor with the desired item, then adjust with the cursor (← →) button.

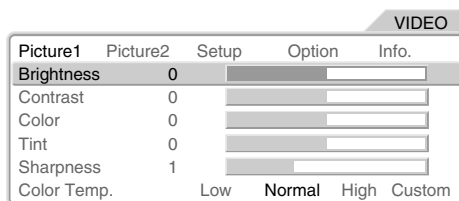

Note: Adjustment values can be stored and read.

→ Page E-36 "Saving and Loading of Video Adjustments"

Tint Adjustment

* Adjustment is not possible with YCbCr input.

* Adjustment is not possible with SECAM video input.

Item Name	Cursor (←) Button	Cursor (→) Button
Brightness	Darker	Brighter
Contrast	Less dense picture	Denser picture
Color	Lighter color	Deeper color
Tint	Heightened red	Heightened green
Sharpness	Softer picture	More distinct picture

Color Temperature

Adjusting the White Balance

This is the input picture white color selection or white and black level correction, and serves to adjust the color reproducibility.

Press the cursor button (↑↓) and align the cursor with the desired item, then adjust with the cursor (← →) button.

Low: Warm white (White with heightened yellow)

Standard: The white of sunlight

High: Cool white (White with heightened blue)

Custom adjustments

Press the cursor button (↓) and align the cursor with [Custom], then press the SET button. The custom adjustment screen will be displayed.

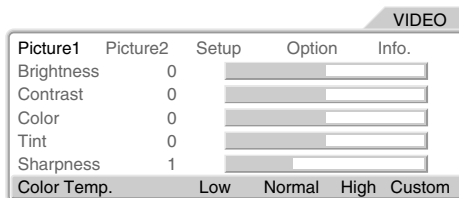

Note: Color temperature (or white balance) refers to the white color that becomes the reference of color representation. White color is expressed by the mixture of red, green, and blue light. The color temperature adjustment serves to adjust the proportions of this mixture. The color representation on the screen will change depending on the environment including room illumination.



[Custom Adjustment Screen]

Input Video Adjustments [Picture 2]

These functions adjust the input video signal.

See → Page E-24 "Using the On-Screen Menu" for information about performing menu operations.

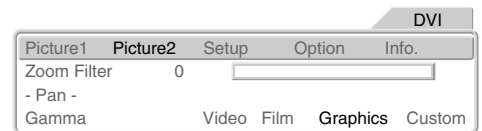
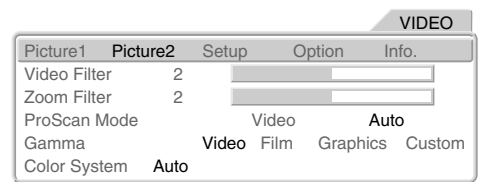

Preparation

- * Project an image.
- * Press the MENU button to display the menu, then select [Picture 2].

Video Filter

Adjusting the Sharpness of the Video Image

This adjustment is used to reduce the roughness and provide a clear picture.

Press the cursor button (↑↓) and align the cursor with the desired item, then adjust with the cursor (← →) button.

Adjust to your preference while viewing the picture. Adjustment can be made from 0 (OFF) to level 4.

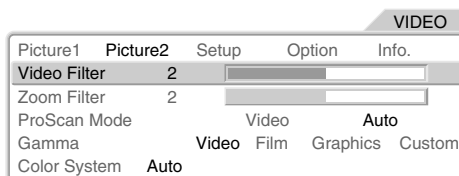

Note: The higher the level, the more proper it is for high resolution.

Zoom Filter

Adjusting the Sharpness When Expanding/Compressing

This adjusts the sharpness of the picture at the time of pixel conversion in the selection of the aspect ratio.

Press the cursor button (↑↓) and align the cursor with the desired item, then adjust with the cursor (← →) button.

Adjust to your preference while viewing the picture. Adjustment can be made from 0 (OFF) to level 4.

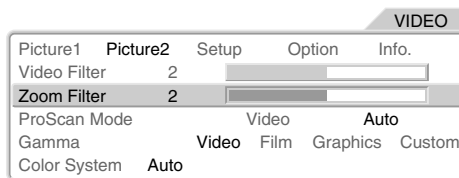

Note: The greater the number of adjustment level becomes, the sharper an image is. The closer to 0 the number of adjustment level becomes, the softer an image is.

ProScan Mode

ProScan Mode Settings

Set this according to the movie material.

Press the cursor button (↑↓) and align the cursor with the [ProScan Mode], then select with the (← →) button.

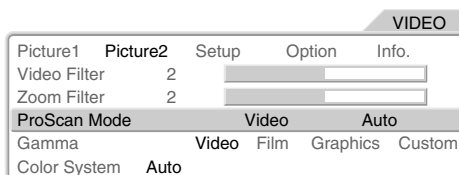

Video: This setting progressive an input signal on the assumption that it is a normal interlaced signal.

Auto: This setting automatically determines whether an input signal is the movie material(24 frames) or the video material (normal interlaced signal) to use progressive scanning.

Pan

Adjustment of Screen Display Position

This is used to adjust the screen position at the time of DVI input selection.

Press the cursor button (↑↓) and align the cursor with [Screen Movement], then press the SET button. The menu display will close and the cursor display will appear.

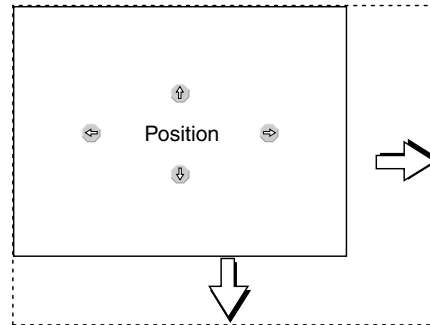
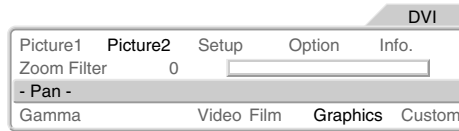

Note: This adjustment is possible only when an image larger than S-VGA is displayed with THRU.

Gamma

Gamma Settings

These are settings of the tone of the image.

Press the cursor (↑↓) button and align the cursor with [Gamma], then select with the cursor (← →) button.

Video: This is a gamma adjustment value suited to video signals.

Film: This is a gamma adjustment value suited to movies.

Graphics: This is a gamma adjustment value suited to graphics such as computer images.

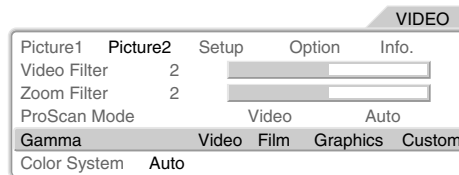

Custom adjustments

This adjustment permits the creation of a desired gamma curve.

This is performed while viewing the target image. Select [Custom] with the cursor (← →) button, then press the SET button.

The custom adjustment screen will be displayed.

1. Press the cursor (← →) button and align the cursor with the index.
2. Select the adjustment point with the cursor (← →) button.
3. Select the color that is to be adjusted with the cursor (↑↓) button, then adjust with the cursor (← →) button.

When required, adjust other adjustment points in the same manner.

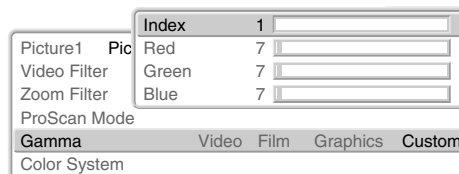

Note: See → Page E-37 "Returning to Standard Settings" for information about returning to the standard setting values. Note that other adjustments and settings will also be reset.

Note: Index (1 to 31) indicates adjustment point of a 32nd part of input values between 0 and 255.

Color System

Video Signal Color System Settings

These settings are of the color system of the composite video signal.

This function is normally set to Auto. If the color system cannot be identified on Auto, set it manually.

Press the (↑↓) cursor button and align the cursor with [Color System], then press the SET button.

The color system selection display will appear.

Press the cursor (↑↓) button and align with the composite video signal system of the input equipment.

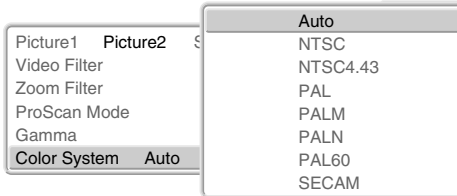

Note:

* The video signal created by adding the color signal to the brightness signal is termed the composite video signal and differs depending on the country.

The color system sets the method of this color signal.

* PAL-M cannot be identified automatically and will need to be set manually.

Note that when PAL-M and other color systems are set manually, the "No Signal" display will not appear during absence of signal input.

The background color under such circumstances will be entirely black.

Setup

These settings are used when setting up the projector.
See → Page E-24 "Using the On-Screen Menu" for information about performing menu operations.

Preparation

- * Project an image.
- * Press the MENU button to display the menu, then select [Setup].

VIDEO			
Picture1	Picture2	Setup	Option
Keystone Mode		Normal	Full
Keystone	+0		
- Installation -			
Background		Blue	Black
Auto Power Off		Off	On
LED		Off	On

Keystone Mode / Keystone

Adjustment of Keystone Distortion
This adjusts keystone distortion in the vertical direction.

Adjust so that left and right sides are parallel.

Press the cursor (↑↓) button and align the cursor with [Keystone Mode], then press the cursor (← →) button and select the mode.

VIDEO			
Picture1	Picture2	Setup	Option
Keystone Mode		Normal	Full
Keystone	+0		
- Installation -			
Background		Blue	Black
Auto Power Off		Off	On
LED		Off	On

Note: Keystone distortion arises when the projector is not installed level, or when the screen is inclined which results in a difference in the distance of upper and lower projection points. Keystone correction compensates for this. This projector has two correction modes.

- Normal:** Corrects while maintaining the aspect ratio.
- Full:** Corrects by enlarging the width at the top to a full sized screen.

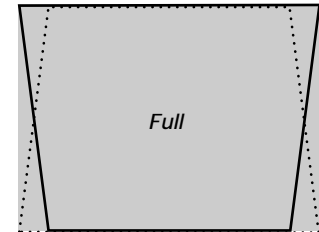
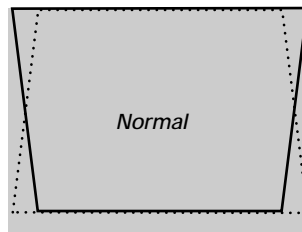

Adjustment of Keystone Distortion

Press the cursor (↓) button and align the cursor with [Keystone Mode], then press the cursor (← →) button to correct the keystone distribution.

VIDEO			
Picture1	Picture2	Setup	Option
Keystone Mode		Normal	Full
Keystone	+0		
- Installation -			
Background		Blue	Black
Auto Power Off		Off	On
LED		Off	On

Installation

Screen Projection System Settings
These settings are for setting projection from the front of the screen and from the rear of the screen.

Press the cursor (↑↓) button and align the cursor with [Installation], then press the SET button. The setup screen will be displayed.

VIDEO			
Picture1	Picture2	Setup	Option
Keystone Mode		Normal	Full
Keystone	+0		
- Installation -			
Background		Blue	Black
Auto Power Off		Off	On
LED		Off	On

Note: When projecting from the rear of the screen, a translucent type screen is required.

- Floor - Front**
Projection is from the front of the screen.
- Floor - Rear**
Projection is from the rear of the screen.
- Ceiling - Front**
Ceiling installation with projection from the front.
- Ceiling - Rear**
Ceiling installation with projection from the rear.

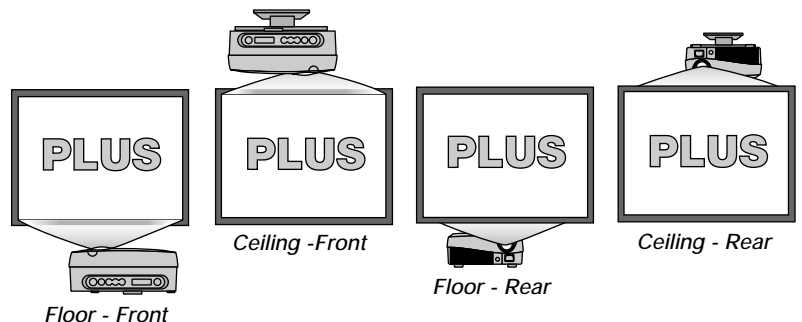

Consult your dealer or installer for special installation such as ceiling mounting.

Background

Background Color Settings

This sets the background color when a signal is not being input to the connector of the projector.

Press the cursor (↑↓) button and align the cursor with [Background], then make the selection with the cursor (← →) button.

- Blue:** Displays a blue screen.
- Black:** Displays a black screen.

Picture1	Picture2	Setup	Option	Info.
Keystone Mode			Normal	Full
Keystone	+0	<input type="text"/>		
- Installation -				
			Blue	Black
Auto Power Off			Off	On
LED			Off	On

Note: When the menu display is closed after making the setting, the color will change to the background color that has been set.

Auto Power Off

Auto Standby Settings

This setting automatically sets the power to the standby mode when a no-signal condition has existed at the connector of the projector for 5 minutes or longer.

Press the cursor (↑↓) button and align the cursor with [Auto Power Off], then make the selection with the cursor (← →) button.

- Off:** Not operational
- On:** Operational

Picture1	Picture2	Setup	Option	Info.
Keystone Mode			Normal	Full
Keystone	+0	<input type="text"/>		
- Installation -				
			Blue	Black
Auto Power Off			Off	On
LED			Off	On

Note:

- * The projector will automatically switch to the standby mode when the "No Signal" display has been projected for about 5 minutes. Some video equipment such as video tape decks are designed to display a blue background when playback has finished. In this instance, the projector is receiving a signal and so it does not produce its own background.
- * To project an image again, press the ON/STANDBY button and switch on the power.

LED

LED Display Settings

This setting is used when the light of the POWER/STANDBY indicator (LED) of the main unit is objectionable during projection in a dark room.

Press the cursor (↑↓) button and align the cursor with [LED], then make the selection with the cursor (← →) button.

- Off:** Switches off the LED.
- On:** Lights the LED.

Picture1	Picture2	Setup	Option	Info.
Keystone Mode			Normal	Full
Keystone	+0	<input type="text"/>		
- Installation -				
			Blue	Black
Auto Power Off			Off	On
LED			Off	On

Attention!
 When this function is used to switch off the LED and the background color is set to black, the projector may mistakenly be assumed to be in the standby mode. Do not mistakenly switch off the main power or disconnect the power cord. Doing so may shorten the life of the lamp and cause breakdown.

On-Screen Display Settings [Option]

These settings are for the menu and language that will be displayed on the screen. See → Page E-24 "Using the On-Screen Menu" for information about performing menu operations.

Preparation

Press the MENU button to display the menu, then select [Option].



Language

On-Screen Display Language Settings

This is the setting of the language that is displayed on screen when the input is switched, a menu is displayed, etc.

Press the cursor (↑↓) button and align the cursor with [Language], then press the cursor (← →) button and select the language.

En: English, **De:** German, **Fr:** French, **It:** Italian,
Es: Spanish, **Sv:** Swedish, **中:** Chinese, **日:** Japanese



Note: Even when a different language has been selected, "No Signal" will appear in English.

Menu Position

Moving the Menu Display Position

This function changes the display position of the on-screen menu.

Press the cursor (↑↓) button and align the cursor with [Menu Position], then press the SET button and the display will change to the menu position display.

Use the cursor (← →↑↓) buttons to move the [Menu Position] display.

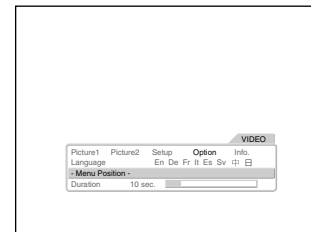
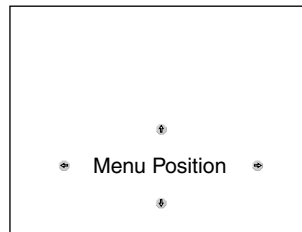

Duration

On-Screen Display Duration Setting

This is the setting of the time that is displayed on screen when the input is switched, a menu is displayed, etc.

Press the cursor (↑↓) button and align the cursor with [Duration], then press the cursor (← →) button and select the desired time.

Settings can be made from 5 seconds to 30 seconds in 5-second units.



Resetting, Storing, and Information [Info.]

This function performs resetting and the display of information for the method of using the user memory, the default values of adjustments and settings, and the lamp timer.

See → Page E-24 "Using the On-Screen Menu" for information about performing menu operations.

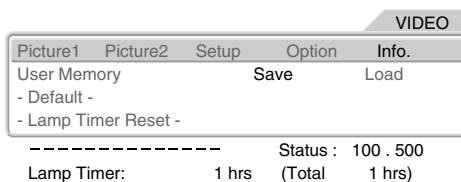

Preparation

Press the MENU button to display the menu, then select [Info.].

User Memory

Saving and Loading of Video Adjustments

This function saves video adjustment and setting values, and can load them when required. Saving can be performed independently for the inputs of VIDEO, S-VIDEO and YCbCr.

Items that can be saved: Menu items of [Picture 1] and [Picture 2]

Saving

1. Project the saved image and adjust the menu items of [Picture 1] and [Picture 2]. The menu can be closed without causing problems. When closing, select [Info.] of the menu.
2. Press the cursor (↑↓) button and align the cursor with [User Memory], then press the cursor (← →) button and select [Save], finally press the SET button.
3. The message display will change to "Save User Memory." Press the SET button.
(Press the SET button while the message is displayed.)

This will save the video adjustment and setting values of the current input mode.

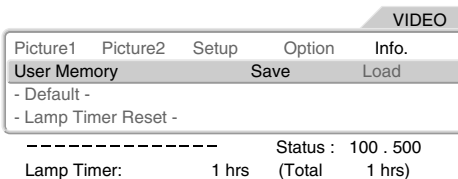

Note:

- * The [Save] operation overwrites the previous adjustment values.
- * Saving can be performed independently for each input. In the load operation, the adjustment and setting values that have been saved for that input mode are loaded.

Loading

1. Project the image that you want to save.
2. Press the cursor (↑↓) button and align the cursor with [User Memory], then press the cursor (← →) button and select [Load], finally press the SET button.
3. The message display will change to "Load User Memory." Press the SET button.
(Press the SET button while the message is displayed.)

This will change the image to that of the loaded adjustment and setting values.

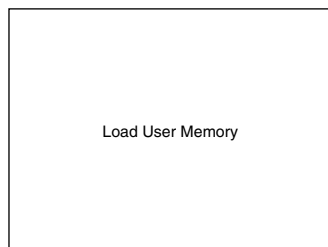
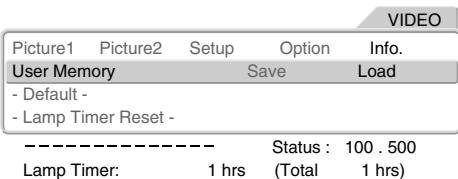

Default

Returning to Standard Settings

This function is used to return the adjustments and settings of the current signal to the standard settings. Select the signal you wish to return to the default settings first before doing so.

Press the cursor (↑↓) button and align the cursor with [Default], then press the SET button.

The message display will change to: Press "Set" to Reset Menu.

Press the SET button while the message is displayed.

This results in a return to the standard settings.

Items returned to default settings

[Option]: Language

[Info.]: Lamp timer, User Memory

Picture1	Picture2	Setup	Option	Info.
User Memory			Save	Load
- Default -				
- Lamp Timer Reset -				
-----				Status : 100 . 500
Lamp Timer:	1 hrs	(Total	1 hrs)	



Note: Items that cannot be specified for each input will be returned to the initial settings.

Note: When the video adjustments have not been returned to the defaults, use the user memory. See → Page E-36 "Saving and Loading of Video Adjustments."

Lamp Timer Reset

Resetting the Lamp Timer

This reset is used when replacing the lamp cartridge. Be certain to reset this, since it is used in the display of the lamp timer.

1. Press the cursor (↑↓) button and align the cursor with [Lamp Timer Reset], then press the SET button. The message display will change to "Lamp Timer Reset."
2. While the message is being displayed, select "No" or "Yes" with the cursor (← →) button, then press the SET button. The message will change to [Press "SET" to Lamp Timer Reset].
3. While the message is being displayed, press the SET button.

This will reset the lamp timer and set the time to 0.

Picture1	Picture2	Setup	Option	Info.
User Memory			Save	Load
- Default -				
- Lamp Timer Reset -				
-----				Status : 100 . 500
Lamp Timer:	1 hrs	(Total	1 hrs)	

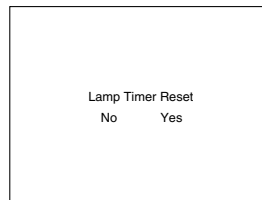

Note: The projector will no longer start when the lamp timer exceeds 1,100 hours. As a result, it will not be possible to reset the lamp timer through timer operations.

Should this situation arise, set to the standby condition and press the SOURCE button and the ASPECT button of the main unit at the same time for at least 5 seconds. When reset, the STATUS indicator will go off.

Info.

Viewing the Lamp Timer/Resolution and Frequency

This function is used to check the lamp timer (for a check of the lamp cartridge replacement time) and the resolution and frequency at the time of DVI input.

[VIDEO, S-VIDEO, and YCbCr Input Selection]

Picture1	Picture2	Setup	Option	Info.
User Memory			Save	Load
- Default -				
- Lamp Timer Reset -				
-----				Status : 100 . 500
Lamp Timer:	1 hrs	(Total	1 hrs)	

[DVI Input Selection]

Picture1	Picture2	Setup	Option	Info.
- Default -				
- Lamp Timer Reset -				
-----				Status : 100 . 500
Resolution:	800 X 600			
Frequency:	H: 37.8KHz	V: 60Hz		
Lamp Timer:	1 hrs	(Total	1 hrs)	

Note: Replacing the lamp cartridge and resetting the lamp timer will not reset the total number of operating hours. The total number of operating hours indicates the usage time of the projector from date of dispatch to the present.

Troubleshooting

Check the following matters before requesting servicing.

Problem	Check	Reference Page
No power (POWER/ ϕ indicator does not light)	<ul style="list-style-type: none"> * Has the power plug become disconnected from the outlet? * Is the lamp cover properly attached? * Has the internal temperature become high? When the internal temperature becomes very high, to protect the unit the power will not switch on. * Has the lamp timer exceeded 1,100 hours? The power will no longer switch on once the timer has exceeded 1,100 hours. 	<p>E-14 E-40 E-39 E-37, 40</p>
No video	<ul style="list-style-type: none"> * Has the connected input been selected? * Is the cable of the input connector properly connected? * Are the Picture 1 brightness and contrast adjustments (incorrectly) set to a minimum? * Has the lamp burned out? * In the case of DVI input, has a signal other than a supported signal type been input? * Is the STATUS indicator flashing? 	<p>E-20, 23 E-15 – 17 E-29 E-39, 40 E-17 E-39</p>
Distorted video	<ul style="list-style-type: none"> * Is the projector installed properly? * Is the keystone adjustment properly adjusted? 	<p>E-19 E-33</p>
Blurred video	<ul style="list-style-type: none"> * Is the lens properly focussed? * Are the projection screen and the projector installed at the proper angle? * Has the projection distance exceeded the focussing range? * Is there condensation on the lens and other parts? <p>When the projector has been stored in a cold location and the power is switched on in a warm location, there may be condensation on the lens and other internal optical parts. Should this occur, wait several minutes until the condensation disappears.</p>	<p>E-19 E-19 E-13 –</p>
Image position is shifted and doesn't display properly	<ul style="list-style-type: none"> * Is the input signal being supported for resolution and frequency? Check the resolution of your personal computer. 	<p>E-37</p>
Image is broken	<ul style="list-style-type: none"> * When the image is broken in the horizontal or vertical direction, or the image does not fill the entire screen, select a suitable aspect ratio. 	<p>E-20, 23</p>
Remote control does not function	<ul style="list-style-type: none"> * Is an obstacle located between the remote control and the remote control sensor of the main unit? * Is the remote control out of range for its signal to reach the sensor? * Is there strong light or a fluorescent lamp in the vicinity of the sensor? * Are the batteries weak? Try directing the remote control toward the remote control sensor from a close distance and operating it. If there is difficulty in changing settings, the batteries are weak. Replace the batteries with new ones. 	<p>E-11 E-11 – E-11</p>
STATUS indicator lights or flashes	<ul style="list-style-type: none"> * See the STATUS indicator list. 	<p>E-39</p>
POWER/ ϕ indicator is off while projecting	<ul style="list-style-type: none"> * Has the LED been set to off? 	<p>E-34</p>

When the STATUS Indicator Is Lit/Flashes

The faults described below are being indicated when the indicators of the projector control panel are lit or flashing.

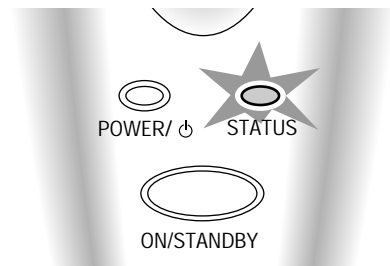

Indicator Display	Projector Condition	Action to Be Taken
Off	Normal operation	* It is time to replace the lamp. Replace with a new lamp.
Lit	Time for lamp replacement	* Is the lamp cover attached properly? If not, attach it properly.
Flashing at 1-second intervals (0.5 s lit / 0.5 s off)	Cover is open	* The thermal protector has been activated. If the room temperature is high, move the projector to a cool location. If the internal temperature of the projector is high, check the cooling fan ventilation holes and clean them if they are obstructed.
Flashing once every 4 seconds (2 s lit / 2 s off)	Temperature error	* The thermal protector has been activated. If the room temperature is high, move the projector to a cool location. If the internal temperature of the projector is high, check the cooling fan ventilation holes and clean them if they are obstructed. * When the thermal protector is activated and the unit is set to the standby mode and soon thereafter the power is switched ON, the unit may not power up. Should this occur, wait for one minute and then switch it ON again.
	Lamp lighting voltage fault	* The lamp lighting voltage fault detection protector has been activated. Wait for at least one minute and switch on the power again. If the unit still does not operate, please contact your store of purchase.
Flashing once every 8 seconds (4 s lit / 4 s off)	Fan fault	* The cooling fan has stopped. Consult your PLUS dealer.
Flashing once every 12 seconds (6 s lit / 6 s off)	Lamp power error	* The lamp does not light. First turn off the main power, then wait at least one minute, then switch on the power again. If the unit still does not operate, consult your dealer.

Thermal Protector

When the internal temperature of the projector becomes abnormally high, the STATUS indicator will flash (at an interval of once every 4 seconds).

At the same time, the temperature protector is activated and the projector power may be switched off.

Should this occur, proceed with the following actions.

1. Switch off the power and disconnect the power plug from the wall outlet.
2. Check the following matters and take the required measures.
When the projector is being used in a location that has a high ambient temperature, install it in a cool location. Check the outflow and intake holes and clean them if they are obstructed.
3. Wait about 60 minutes until the temperature of the projector drops.
If after having performed the above matters, the problem still has not been solved, consult your PLUS dealer.

Replacing the Lamp Cartridge

- After the lamp has been operating for 1000 hours or longer, the STATUS indicator will light and the message "Replace The Lamp" will appear on the screen. Should this happen, turn off the projector and replace the lamp cartridge with a new one. The projector will not turn on after 1100 hours.
- Obtain a replacement lamp cartridge at the store where the projector was purchased. Please specify the following information when ordering a replacement lamp cartridge:
Unit model number: HE-3100L for the exclusive use of HE-3100
Part number: 27-050.

NOTE: The projector lamp has its usable life. The rated lamp life is about 1000 hours. However, it may become shorter depending on the conditions of usage.
(The rated lamp life is the average life of the lamps produced and tested, under the test conditions of our company, for a long term.)

CAUTION

- Follow these steps before replacing the lamp cartridge:
- Press the ON/STANDBY button on the remote control to turn off the power. The POWER/ ⏻ indicator will change to steady light in green from flashing in amber.
 - Press the POWER button on the projector cabinet turn off the projector.
 - Unplug the power cord.
 - Wait at least 60 minutes for the lamp cartridge to cool.
 - DO NOT TOUCH THE LAMP CARTRIDGE immediately after it has been used. It will be extremely hot.
 - Do not remove any screws except for those mentioned in the instructions below.
 - Do not touch the lamp. Doing so may shorten the lamp life.
 - The lamp may explode if improperly mishandled.
 - If lamp has reached the end of its usable life, the lamp bulb may shatter. When this happens, an explosive sound can be heard and pieces of glass may be scattered in the lamp cartridge. Do not touch them as the pieces of glass may cause injury. If this happens, contact your dealer or the store where the projector was purchased.

Preparation: Unplug the projector. Prepare the new lamp cartridge and a plus-headed screwdriver.
Lay a soft cloth sheet underneath the projector with its upside down to prevent scratches.

1 Remove the lamp cover.

- ① Loosen the lamp cover screw until it turns freely.
- ② Remove the lamp cover.

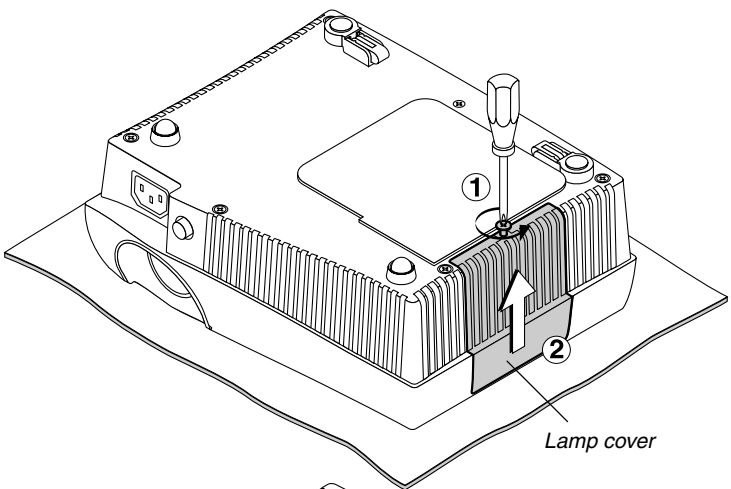

2 Remove the lamp cartridge.

- ① Loosen the lamp cartridge screw until it turns freely.
- ② Hold the handle of the lamp cartridge and then pull out the lamp cartridge.

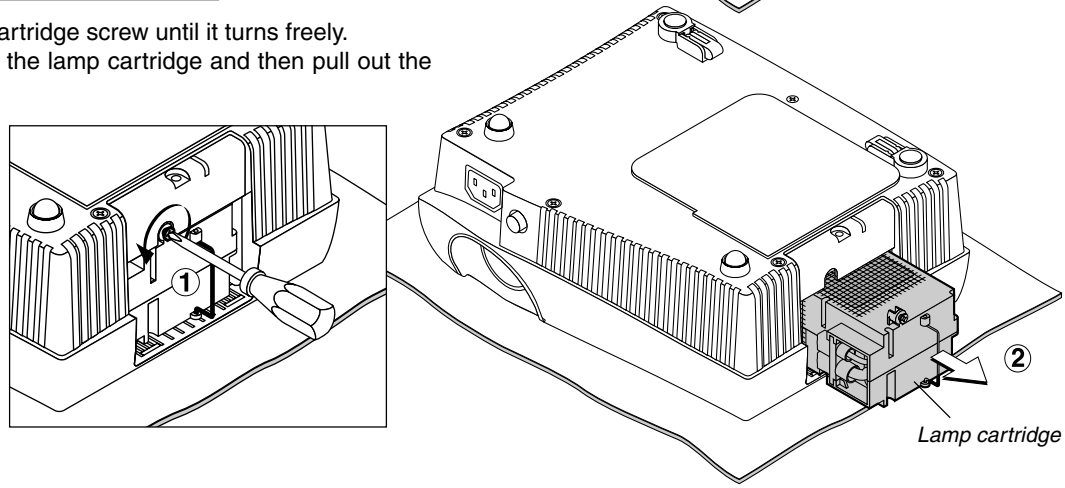

3 Install the new lamp cartridge.

- ① Install the new lamp cartridge in the direction as shown in the drawing.

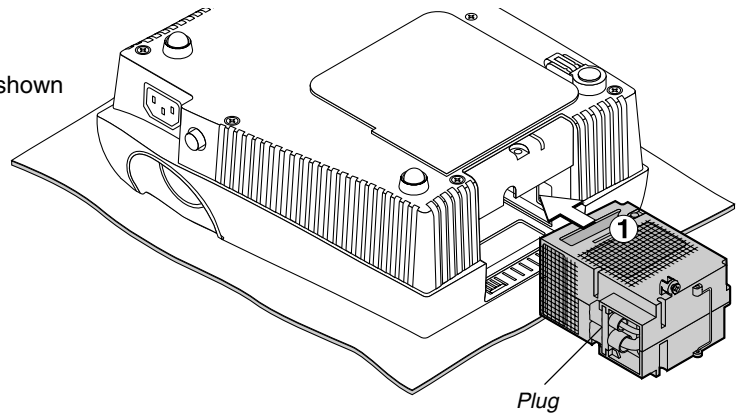

- ② Tighten the lamp cartridge screw.
(Put down the handle of the lamp cartridge.)

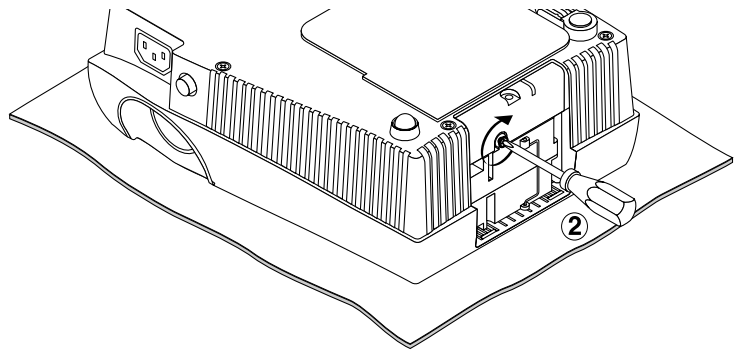

4 Reinstall the lamp cover.

- ① Insert the lamp cover until the catches fit in the grooves.
- ② Tighten the lamp cover screw.

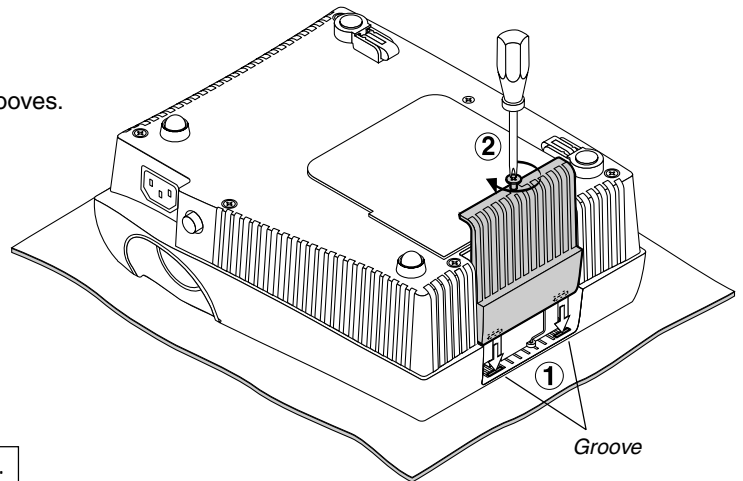

5 Reset the lamp usage hours to zero.

From the menu, select [Info.] → [Lamp Timer Reset] and then reset the lamp usage hours. See "Resetting the Lamp Timer" on page E-37.

NOTE: When the projector lamp has exceeded 1100 hours of operation, the projector will not turn on. This means you cannot reset the lamp usage on the menu. Should this happen, press SOURCE and ASPECT on the projector cabinet for at least of 5 seconds at the same time when the projector is in standby mode. When the lamp usage is reset, the STATUS indicator goes off.

[This completes the lamp replacement.]

Cleaning

Attention!

- * *Be certain to disconnect the power plug from the power outlet before cleaning.*
- * *Do not spray or otherwise expose the projector, lens, or screen to volatile substances such as insecticides. Doing so could cause them to undergo qualitative changes or the coatings may peel, etc.*

Cleaning a Soiled Projector Main Unit

- * Wipe with a lint-free, soft, dry cloth.
When very dirty, wipe with a cloth that has been moistened with a diluted neutral detergent, then finish with a dry cloth. If a chemically-treated cloth is going to be used, please follow any written warnings.
- * Do not wipe with thinner, benzene, or other solvents. Doing so could cause them to undergo qualitative changes or the coatings may peel, etc.
- * When removing the dust of the outflow and intake holes, use the brush attachment on a vacuum cleaner to clean out the dust. Avoid using the vacuum directly without attaching the adapter as well as the use of a nozzle adapter.
- * Do not scratch or otherwise hit the projector body with your nails or other hard object, since this will cause scratches.

Dirty Lens

The lens surface has been treated with a special coating. Consult your PLUS dealer for cleaning.

Dust of the Intake and Outflow Holes

Dust that collects in the intake and outflow holes will obstruct the ventilation and cause the internal temperature to rise which could cause damage. Clean this area carefully. As a guideline, clean at least every 100 hours.

- * Switch off the power with the ON/STANDBY button and check that the POWER/ ϕ indicator has changed to a steadily lit orange, then switch off the main power with the POWER switch of the main unit. Finally, disconnect the power cord.
- * Clean out the holes from the outside using a vacuum cleaner. Use the brush adapter of the vacuum cleaner to do this. Avoid using the vacuum directly without attaching the adapter as well as the use of a nozzle adapter.

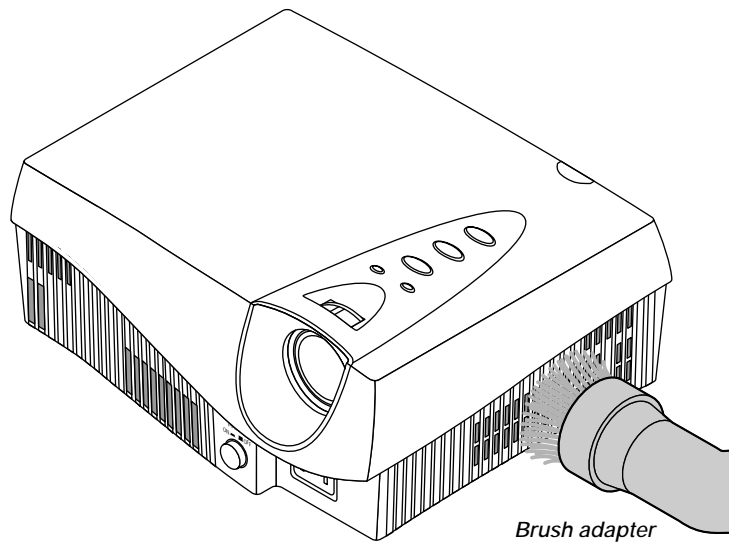

Cleaning the Inside of the Projector

Cleaning of the inside of the projector is required about once a year. Failure to clean over a long period while dust has collected inside the projector could cause a fire or breakdown. Do not clean the inside of the projector by yourself. Be sure to consult your PLUS dealer.

Specifications

Model Name	HE-3100
Display Method	Single Chip Digital Micromirror Device (DMD™)
DMD Panel	0.7" 508,800 pixels (848 x 600)
Lens	Manual focus F=3.0 f=23mm
Lamp	130W High Performance Compact Lamp
Image Size	Min. 36" (Throw distance 1.2m / 3.9 feet) Max. 200" (Throw distance 6.9m / 22.6 feet)
Color Reproduction	Full color, 16.7 million colors simultaneously
Light Output	450 ANSI lumens (normally white)
Contrast Ratio	700:1 (Full on/off)
Scanning Frequency	Horizontal :15 - 85 kHz Vertical :50 - 85 Hz
Functions	Focus(Manual), Projection angle, Source select (Video/S-Video/YcbCr/DVI), Aspect, Standby On/Off, Projection orientation, Digital keystone correction, Brightness, Contrast, Color, Tint*1, Sharpness, Color temperature, Gamma correction
Digital RGB Input	T.M.D.S-compliant (single link only)
Input Terminal	DVI-D 24 pin x 1
RGB Signal	VGA (640 x 480) enlarged/ SVGA (800 x 600) full, XGA (1024 x 768) compressed
Component Input	Component Y (luminance signal) : 1.0Vp-p/75Ω, Cb, Cr : 0.7Vp-p/75Ω RCA x 3
Video Input	NTSC 3.58, NTSC 4.43, PAL, PAL N, PAL M, PAL60, SECAM Composite : 1.0Vp-p/75Ω S-Video : Y (1.0Vp-p/75Ω), C (0.286Vp-p/75Ω) RCA x 1, 4-pin mini DIN x 1
Horizontal Resolution	NTSC: 400 lines or more
Environment	Operating temperature: 5 - 35°C / 41 - 95°F, 30 - 85% humidity (no-condensing) Storage temperature: -10 - 60°C / 14 - 140°F, 10 - 85% humidity (no-condensing)
Power Requirement	100 - 240V AC, 50 / 60Hz
Power Consumption	200 W (STANDBY 18W)
Dimensions	235 (W) x 91 (H) x 198 (D) mm (not including protrusion) 9.3 (W) x 3.6 (H) x 7.8 (D) inch (not including protrusion)
Weight	2.0kg / 4.4 lbs
Regulations	UL Approved (UL 6500, CSA-E60065) Meets FCC Class B requirements Meets EMC Directive (EN55022, EN55024) Meets Low Voltage Directive (EN60065)



*1: Not available on SECAM signal

Main Unit External View

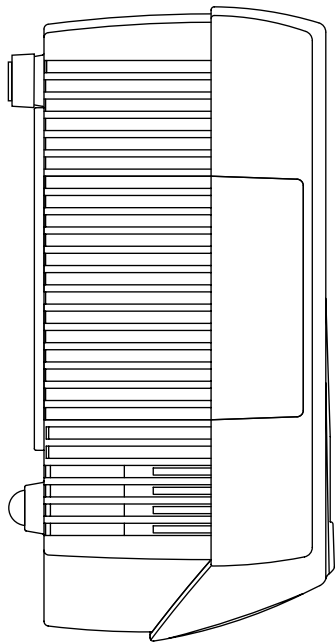
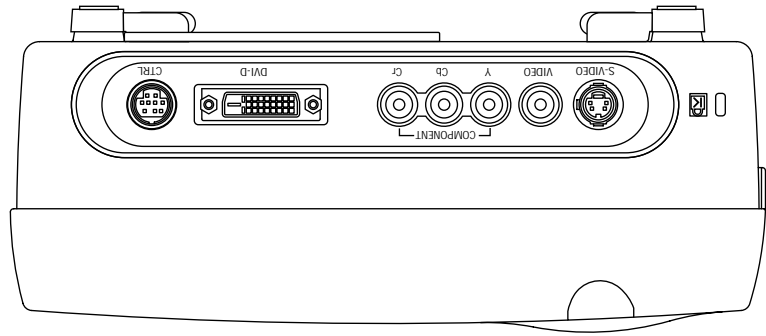

174 mm / 6.9 inch

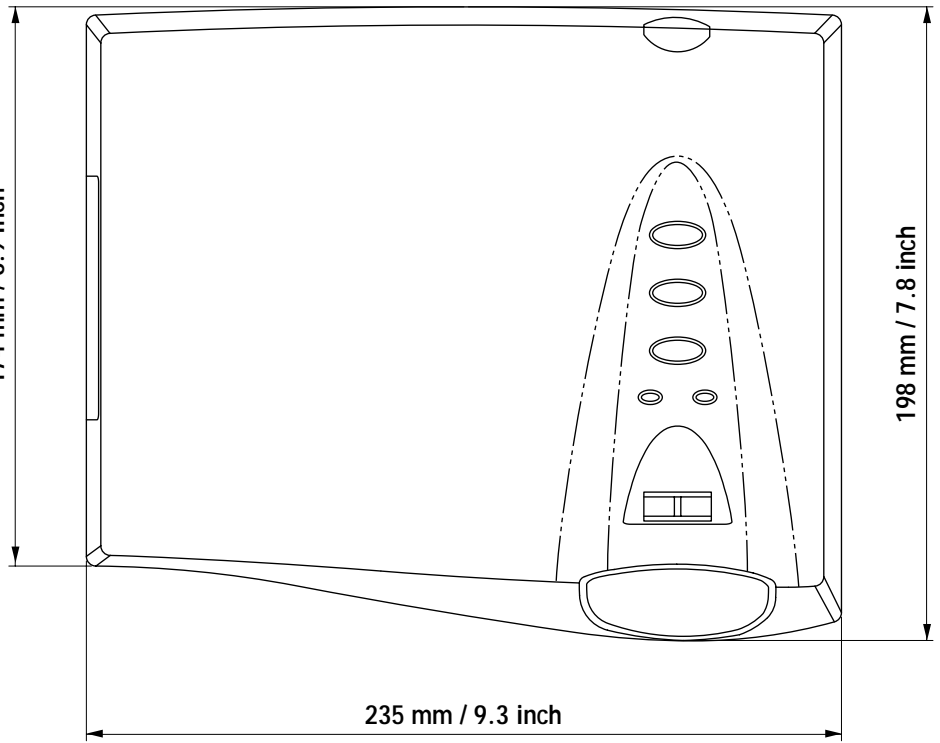

235 mm / 9.3 inch

198 mm / 7.8 inch

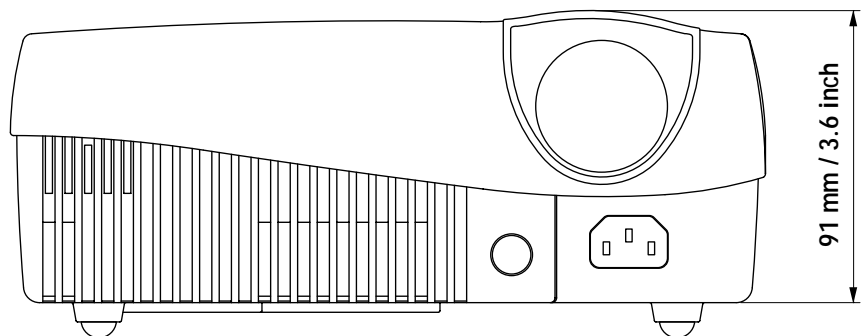

91 mm / 3.6 inch