

***myprojectorlamps.com***

**The most trusted, dependable name  
in projector lamp sales.**



<http://www.myprojectorlamps.com>



<http://www.myprojectorlamps.ca>



<http://www.myprojectorlamps.eu>

The following projector manual has not been modified or altered in any way.

# Panasonic®

## Operating Instructions

LCD Projector **Commercial Use**

Model No. **PT-LB80NTE**  
**PT-LB80E**  
**PT-LB78E**  
**PT-LB75NTE**  
**PT-LB75E**

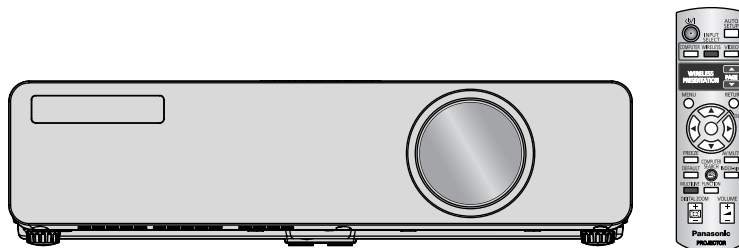

Before operating this product, please read the instructions carefully and save this manual for future use.

TQBJ0245-3

**ENGLISH**

# Important Safety Notice

## Dear Panasonic Customer:

This instruction booklet provides all the necessary operating information that you might require. We hope it will help you to get the most out of your new product, and that you will be pleased with your Panasonic LCD projector. The serial number of your product may be found on its bottom. You should note it in the space provided below and retain this booklet in case service is required.

Model number: **PT-LB80NTE / PT-LB80E / PT-LB78E / PT-LB75NTE / PT-LB75E**

Serial number:

**WARNING:** THIS APPARATUS MUST BE EARTHED.

**WARNING:** To prevent damage which may result in fire or shock hazard, do not expose this appliance to rain or moisture.

Machine Noise Information Ordinance 3. GSGV, January 18, 1991: The sound pressure level at the operator position is equal or less than 70 dB (A) according to ISO 7779.

**WARNING:**

1. Remove the plug from the mains socket when this unit is not in use for a prolonged period of time.
2. To prevent electric shock, do not remove cover. No user serviceable parts inside. Refer servicing to qualified service personnel.
3. Do not remove the earthing pin on the mains plug. This apparatus is equipped with a three prong earthing-type mains plug. This plug will only fit an earthing-type mains socket. This is a safety feature. If you are unable to insert the plug into the mains socket, contact an electrician. Do not defeat the purpose of the earthing plug.

**CAUTION:** To assure continued compliance, follow the attached installation instructions, which includes using the provided power cord and shielded interface cables when connecting to computer or peripheral device. Any unauthorized changes or modifications to this equipment will void the user's authority to operate.

Pursuant to at the directive 2004/108/EC, article 9(2)  
Panasonic Testing Centre  
Panasonic Service Europe, a division of Panasonic Marketing Europe GmbH  
Winsbergring 15, 22525 Hamburg, F.R. Germany



**Information for Users on Collection and Disposal of Old Equipment and used Batteries**

These symbols on the products, packaging, and/or accompanying documents mean that used electrical and electronic products and batteries should not be mixed with general household waste.

For proper treatment, recovery and recycling of old products and used batteries, please take them to applicable collection points, in accordance with your national legislation and the Directives 2002/96/EC and 2006/66/EC.

By disposing of these products and batteries correctly, you will help to save valuable resources and prevent any potential negative effects on human health and the environment which could otherwise arise from inappropriate waste handling.



For more information about collection and recycling of old products and batteries, please contact your local municipality, your waste disposal service or the point of sale where you purchased the items.

Penalties may be applicable for incorrect disposal of this waste, in accordance with national legislation.

**For business users in the European Union**

If you wish to discard electrical and electronic equipment, please contact your dealer or supplier for further information.



**Information on Disposal in other Countries outside the European Union**

These symbols are only valid in the European Union. If you wish to discard these items, please contact your local authorities or dealer and ask for the correct method of disposal.

**Note for the battery symbol (bottom two symbol examples):**

This symbol might be used in combination with a chemical symbol. In this case it complies with the requirement set by the Directive for the chemical involved.

## Important Safety Information

### Declaration of Conformity



#### Declaration of Conformity (DoC)

This equipment is in compliance with the essential requirements and other relevant provisions of Directive 1999/5/EC.

Customers can download a copy of the original DoC for this product from our DoC server: <http://www.doc.panasonic.de>

Contact in the EU: Panasonic Services Europe, a Division of Panasonic Marketing Europe GmbH, Panasonic Testing Centre, Winsbergring 15, 22525 Hamburg, F.R.Germany

This product is intended to be used in the following countries.

Austria, Belgium, Bulgaria, Czech, Cyprus, Denmark, Estonia, Finland, France, Germany, Greece, Hungary, Iceland, Ireland, Italy, Latvia, Lithuania, Luxembourg, Malta, Netherlands, Norway, Poland, Portugal, Romania, Slovenia, Slovak, Spain, Sweden, Switzerland & UK



#### Konformitätserklärung (KE)

Dieses Gerät entspricht den grundlegenden Anforderungen und den weiteren entsprechenden Vorgaben der Richtlinie 1999/5/EU.

Kunden können eine Kopie der Original-KE für dieses Produkt von unserem KE-Server herunterladen: <http://www.doc.panasonic.de>

Kontaktadresse in der EG: Panasonic Services Europe, a Division of Panasonic Marketing Europe GmbH, Panasonic Testing Centre, Winsbergring 15, 22525 Hamburg, F.R.Germany

Dieses Produkt ist für den Einsatz in den folgenden Ländern vorgesehen.

Österreich, Belgien, Bulgarien, Tschechische Republik, Zypern, Dänemark, Estland, Finnland, Frankreich, Deutschland, Griechenland, Ungarn, Island, Irland, Italien, Lettland, Litauen, Luxemburg, Malta, Niederlande, Norwegen, Polen, Portugal, Rumänien, Slowenien, Slowakei, Spanien, Schweden, Schweiz und Großbritannien



#### Déclaration de Conformité (DC)

Cet appareil est conforme aux exigences essentielles et aux autres dispositions pertinentes de la Directive 1999/5/EC.

Les clients peuvent télécharger une copie de la DC originale pour ce produit à partir de notre serveur DC: <http://www.doc.panasonic.de>

Coordonnées dans l'UE : Panasonic Services Europe, a Division of Panasonic Marketing Europe GmbH, Panasonic Testing Centre, Winsbergring 15, 22525 Hamburg, F.R.Germany

Ce produit est conçu pour l'utilisation dans les pays suivants.

Autriche, Belgique, Bulgarie, République Tchèque, Chypre, Danemark, Estonie, Finlande, France, Allemagne, Grèce, Hongrie, Islande, Irlande, Italie, Lettonie, Lituanie, Luxembourg, Malte, Pays-Bas, Norvège, Pologne, Portugal, Roumanie, Slovaquie, Espagne, Suède, Suisse et Royaume-Uni



#### Declaración de conformidad (DC)

Este equipo cumple con los requisitos esenciales así como con otras disposiciones de la Directiva 1999/5/CE.

El cliente puede descargar una copia de la DC original de este producto desde nuestro servidor DC: <http://www.doc.panasonic.de>

Contacto en la U.E.: Panasonic Services Europe, a Division of Panasonic Marketing Europe GmbH, Panasonic Testing Centre, Winsbergring 15, 22525 Hamburg, F.R.Germany

Este producto ha sido desarrollado para el uso en los siguientes países.

Austria, Bélgica, Bulgaria, República Checa, Chipre, Dinamarca, Estonia, Finlandia, Francia, Alemania, Grecia, Hungría, Islandia, Irlanda, Italia, Letonia, Lituania, Luxemburgo, Malta, Holanda, Noruega, Polonia, Portugal, Rumania, Eslovenia, Eslovaquia, España, Suecia, Suiza y el Reino Unido



#### Dichiarazione di conformità (DoC)

Questo apparato è conforme ai requisiti essenziali ed agli altri principi sanciti dalla Direttiva 1999/5/CE.

I clienti possono scaricare la copia del DoC originale per questo prodotto dal nostro server DoC: <http://www.doc.panasonic.de>

Contatto nella EU: Panasonic Services Europe, a Division of Panasonic Marketing Europe GmbH, Panasonic Testing Centre, Winsbergring 15, 22525 Hamburg, F.R.Germany

I prodotti sono stati prodotti per l'uso nei seguenti paesi.

Austria, Belgio, Bulgaria, Repubblica Ceca, Cipro, Danimarca, Estonia, Finlandia, Francia, Germania, Grecia, Irlanda, Islanda, Italia, Lettonia, Lituania, Lussemburgo, Malta, Olanda, Norvegia, Polonia, Portogallo, Romania, Regno Unito, Slovenia, Slovacchia, Spagna, Svezia, Svizzera, Ungheria

## България

Това устройство отговаря на съществените изисквания и останалите приложими разпоредби на Директива 1999/5/ЕО.

## Česky

Toto zařízení je v souladu se základními požadavky a ostatními odpovídajícími ustanoveními Směrnice 1999/5/EC.

## Dansk

Dette udstyr er i overensstemmelse med de væsentlige krav og andre relevante bestemmelser i Direktiv 1999/5/EF.

## Eesti

See seade vastab direktiivi 1999/5/EÜ olulistele nõuetele ja teistele asjakohastele sätetele.

## Ελληνική

Αυτός ο εξοπλισμός είναι σε συμμόρφωση με τις ουσιώδεις απαιτήσεις και άλλες σχετικές διατάξεις της Οδηγίας 1999/5/ΕΚ.

## Íslenska

Þetta tæki er samkvæmt grunnkröfum og öðrum viðeigandi ákvæðum Tilskipunar 1999/5/EC.

## Latviski

Šī iekārta atbilst Direktīvas 1999/5/EK būtiskajām prasībām un citiem ar to saistītajiem noteikumiem.

## Lietuvių

Šis įrenginys tenkina 1999/5/EB Direktyvos esminius reikalavimus ir kitas šios direktyvos nuostatas.

## Nederlands

Dit apparaat voldoet aan de essentiële eisen en andere van toepassing zijnde bepalingen van de Richtlijn 1999/5/EC.

## Malti

Dan I-apparat huwa konformi mal-ħtiġiet essenzjali u I-provedimenti I-oħra rilevanti tad-Direttiva 1999/5/EC.

## Magyar

Ez a készülék teljesíti az alapvető követelményeket és más 1999/5/EK irányelvben meghatározott vonatkozó rendelkezéseket.

## Norsk

Dette utstyret er i samsvar med de grunnleggende krav og andre relevante bestemmelser i EU-direktiv 1999/5/EF.

## Polski

Urządzenie jest zgodne z ogólnymi wymaganiami oraz szczególnymi warunkami określonymi Dyrektywą UE: 1999/5/EC.

## Português

Este equipamento está em conformidade com os requisitos essenciais e outras provisões relevantes da Directiva 1999/5/EC.

## România

Acest echipament este conform cu cerințele de bază și celelalte prevederi relevante ale Directivei 1999/5/CE.

## Slovensko

Ta naprava je skladna z bistvenimi zahtevami in ostalimi relevantnimi pogoji Direktive 1999/5/EC.

## Slovensky

Toto zariadenie je v zhode so základnými požiadavkami a inými príslušnými nariadeniami direktív: 1999/5/EC.

## Suomi

Tämä laite täyttää direktiivin 1999/5/EY olennaiset vaatimukset ja on siinä asetettujen muiden laitetta koskevien määräysten mukainen.

## Svenska

Denna utrustning är i överensstämmelse med de väsentliga kraven och andra relevanta bestämmelser i Direktiv 1999/5/EC.

# Contents

## Quick steps

### 1. Set up your projector

See “Setting up” on page 17.



### 2. Connect with other devices

See “Connections” on page 19.



### 3. Prepare the Remote control

See “Remote control” on page 16.



### 4. Start projecting

See “Switching the projector on/off” on page 20.



### 5. Adjust the image

See “Menu Navigation” on page 29.

- When you start the projection for the first time, the minimum required setting screen for projection will be displayed. See “Minimum required setting screen” on page 13.

## Important Information

<b>Important Safety Notice</b> .....	<b>2</b>
Declaration of Conformity .....	4
<b>Precautions with regard to safety</b> .....	<b>8</b>
WARNINGS .....	8
CAUTIONS .....	9
Cautions when transporting .....	10
Cautions when installing .....	11
Cautions on use .....	11
Security .....	11
Accessories .....	12

## Preparation

<b>Read this first</b> .....	<b>13</b>
Minimum required setting screen .....	13
<b>About Your Projector</b> .....	<b>14</b>
Projector body .....	14
Remote control .....	16

## Getting Started

<b>Setting up</b> .....	<b>17</b>
Screen size and throw distance .....	17
Projection method .....	18
Front leg adjusters and throwing angle .....	18
<b>Connections</b> .....	<b>19</b>
Before connection to the projector .....	19
Connecting example: AV equipment .....	19
Connecting example: Computers .....	19

## Basic Operation

<b>Switching the projector on/off</b> .....	<b>20</b>
Mains lead .....	20
Switching on the projector .....	21
Switching off the projector .....	22
POWER and POWER LOCK indicators .....	23
<b>Projecting an image</b> .....	<b>24</b>
Selecting the input signal .....	24
Positioning the image .....	24
<b>Remote control operation</b> .....	<b>25</b>
Operating range .....	25
Setting up the image position automatically .....	25
Switching the input signal .....	26
Capturing an image .....	26
Stopping the projection temporary .....	26
Resetting to the factory default settings .....	26
Projecting an image in INDEX-WINDOW mode .....	27
Using an assigned function .....	27
Controlling the volume of the speaker .....	27
Enlarging the centred area .....	28

## Settings

<b>Menu Navigation</b> .....	<b>29</b>
Navigating through the MENU .....	29
Main menu and Sub-menu .....	30
<b>PICTURE menu</b> .....	<b>32</b>
PICTURE MODE .....	32
CONTRAST .....	32
BRIGHTNESS .....	32
COLOR .....	32
TINT .....	32
SHARPNESS .....	32
COLOR TEMPERATURE .....	32
DAYLIGHT VIEW .....	32
DETAILED SETUP .....	33
<b>POSITION menu</b> .....	<b>34</b>
REALTIME KEYSTONE .....	34
KEYSTONE .....	34
POSITION .....	34
DOT CLOCK .....	34
CLOCK PHASE .....	34
ASPECT .....	34
FRAME LOCK .....	35
<b>OPTION menu</b> .....	<b>36</b>
INPUT GUIDE .....	36
STARTUP LOGO .....	36
COMPUTER2 SELECT .....	36
RGB/YPBPR .....	36
WIDE MODE .....	36
LAMP POWER .....	37
LAMP RUNTIME .....	37
POWER OFF TIMER .....	37
DIRECT POWER ON .....	37
CONTROL PANEL .....	37
AUTO SETUP .....	37
SIGNAL SEARCH .....	37
INSTALLATION .....	37
ALTITUDE .....	37
FUNCTION BUTTON .....	38
TEST PATTERN .....	38
DETAILED SETUP .....	38
<b>SECURITY menu</b> .....	<b>39</b>
INPUT PASSWORD .....	39
PASSWORD CHANGE .....	39
TEXT DISPLAY .....	39
TEXT CHANGE .....	39
<b>WIRELESS menu</b> .....	<b>40</b>
Items in WIRELESS menu .....	40

## Maintenance

<b>LAMP and TEMP Indicators</b> .....	<b>41</b>
Managing the indicated problems .....	41
<b>Care and Replacement</b> .....	<b>42</b>
Cleaning the projector .....	42
Replacing the Lamp unit .....	43
<b>Troubleshooting</b> .....	<b>45</b>

## Appendix

<b>Technical Information</b> .....	<b>46</b>
List of compatible signals .....	46
Serial terminal .....	47
Computer connection guidance .....	48
Screen size and throw distance for 16:9 aspect ratio .....	49
Specifications .....	50
Dimensions .....	52
Trademark acknowledgements .....	52
<b>Index</b> .....	<b>53</b>

Important Information

Preparation

Getting Started

Basic Operation

Settings

Maintenance

Appendix



# Precautions with regard to safety

## WARNINGS

**If you notice smoke, strange smells or noise coming from the projector, disconnect the mains plug from the mains socket.**

- Do not continue to use the projector in such cases, otherwise fire or electric shocks could result.
- Check that no more smoke is coming out, and then contact an Authorised Service Centre for repairs.
- Do not attempt to repair the projector yourself, as this can be dangerous.

**Do not install this projector in a place which is not strong enough to take the full weight of the projector.**

- If the installation location is not strong enough, it may fall down or tip over, and severe injury or damage could result.

**Installation work (such as ceiling suspension) should only be carried out by a qualified technician.**

- If installation is not carried out correctly, there is the danger that injury or electric shocks may occur.
- Do not use other than an authorised ceiling mount bracket.

**If foreign objects or water get inside the projector, or if the projector is dropped or the cabinet is broken, disconnect the mains plug from the mains socket.**

- Continued use of the projector in this condition may result in fire or electric shocks.
- Contact an Authorised Service Centre for repairs.

**The mains socket shall be installed near the equipment and shall be easily accessible.**

- Unplug the mains plug from the mains socket immediately when problem occurred.

**Do not overload the mains socket.**

- If the power supply is overloaded (for example, by using too many adapters), overheating may occur and fire may result.

**Never attempt to modify or disassemble the projector.**

- High voltages can cause fire or electric shocks.
- For any inspection, adjustment and repair work, please contact an Authorised Service Centre.

**Clean the mains plug regularly to prevent it from becoming covered in dust.**

- If dust builds up on the mains plug, the resulting humidity can damage the insulation, which could result in fire. Pull the mains plug out from the mains socket and wipe it with a dry cloth.
- If not using the projector for an extended period of time, pull the mains plug out from the mains socket.

**Do not handle the mains plug with wet hands.**

- Failure to observe this may result in electric shocks.

**Insert the mains plug securely into the mains socket.**

- If the plug is not inserted correctly, electric shocks or overheating could result.
- Do not use plugs which are damaged or mains sockets which are coming loose from the wall.

**Do not place the projector on top of surfaces which are unstable.**

- If the projector is placed on top of a surface which is sloped or unstable, it may fall down or tip over, and injury or damage could result.
- Do not use the projector at a raised or a horizontally tilted position as it may cause malfunction of the projector.

**Do not place the projector into water or let it become wet.**

- Failure to observe this may result in fire or electric shocks.

**Do not do anything that might damage the mains lead or the mains plug.**

- Do not damage the mains lead, make any modifications to it, place it near any hot objects, bend it excessively, twist it, pull it, place heavy objects on top of it or wrap it into a bundle.
- If the mains lead is used while damaged, electric shocks, short-circuits or fire may result.
- Ask an Authorised Service Centre to carry out any repairs to the mains lead that might be necessary.

**Do not place the projector on soft materials such as carpets or sponge mats.**

- Doing so may cause the projector to overheat, which can cause burns, fire or damage to the projector.

**Do not place liquid containers on top of the projector.**

- If water spills onto the projector or gets inside it, fire or electric shocks could result.
- If any water gets inside the projector, contact an Authorised Service Centre.

**Do not insert any foreign objects into the projector.**

- Do not insert any metal objects or flammable objects into the projector or drop them onto the projector, as doing so can result in fire or electric shocks.

**Do not use the projector in a bath or shower.**

- Fire or electric shocks can result.

**During a thunderstorm, do not touch the projector or the cable.**

- Electric shocks can result.

## Precautions with regard to safety

### Do not place your skin into the light beam while the projector is being used.

- Strong light is emitted from the projector's lens. If you place directly into this light, it can hurt or damage your skin.

### Do not allow the + and - terminals of the batteries to come into contact with metallic objects such as necklaces or hairpins.

- Failure to observe this may cause the batteries to leak, overheat, explode or catch fire.
- Store the batteries in a plastic bag and keep them away from metallic objects.
- Use manganese batteries or alkaline batteries with the remote control.

### Do not touch the leaked liquid from the batteries.

- If you touch the leaked liquid, it may hurt your skin. Immediately wash away the liquid with water and seek medical advice.
- If you get the leaked liquid in your eye, it may cause blindness or damage. Never rub your eye, and immediately wash away the liquid with water and seek medical advice.
- Damaged or insulation may cause leak of battery.

### Do not look into the lens while the projector is being used.

- Strong light is emitted from the projector's lens. If you look directly into this light, it can hurt and damage your eyes.
- Be especially careful not to let young children look into the lens. In addition, turn off the power and disconnect the mains plug when you are away from the projector.

### Do not place your hands or other objects close to the air outlet port.

- Heated air comes out of the air outlet port. Do not place your hands or face, or objects which cannot withstand heat close to this port [allow at least 50 cm (20") of space], otherwise burns or damage could result.

### Replacement of the lamp is recommended to be carried out by a qualified technician.

- The lamp has high internal pressure. If improperly handled, explosion might result.
- The lamp can easily become damaged if struck against hard objects or dropped, and injury or malfunctions may result.

### When replacing the lamp, allow it to cool for at least one hour before handling it.

- The lamp cover gets very hot, and touching it can cause burns.

### Before replacing the lamp, be sure to disconnect the mains plug from the mains socket.

- Electric shocks or explosions can result if this is not done.

### Do not allow infants or pets to touch the remote control unit.

- Keep the remote control unit out of the reach of infants and pets after using it.

## CAUTIONS

### Do not cover the air inlet port or the air outlet port.

- Doing so may cause the projector to overheat, which can cause fire or damage to the projector.
- Do not place the projector in narrow, badly ventilated places such as closets or bookshelves.
- Do not place the projector on cloth or papers, as these materials could be drawn into the air inlet port.

### Do not set up the projector in humid or dusty places or in places where the projector may come into contact with oily smoke or steam.

- Using the projector under such conditions may result in fire, electric shocks or plastic deterioration. The plastic deterioration may cause the falling down of the projector which is mounted in the ceiling.

### Do not set up the projector in a high temperature environment, such as near a heater or in direct sunlight.

- Failure to observe this may result in fire, malfunction or plastic deterioration.

### Do not set up the projector outdoors.

- The projector is designed for indoor use only.

### When disconnecting the mains lead, hold the plug, not the lead.

- If the mains lead itself is pulled, the lead will become damaged, and fire, short-circuits or serious electric shocks may result.

### Always disconnect all cables before moving the projector.

- Moving the projector with cables still attached can damage the cables, which could cause fire or electric shocks to occur.

### Do not place any heavy objects on top of the projector.

- Failure to observe this may cause the projector to become unbalanced and fall, which could result in damage or injury.

## Precautions with regard to safety

### Do not short-circuit, heat or disassemble the batteries or place them into water or fire.

- Failure to observe this may cause the batteries to overheat, leak, explode or catch fire, and burns or other injury may result.

### When inserting the batteries, make sure the polarities (+ and -) are correct.

- If the batteries are inserted incorrectly, they may explode or leak, and fire, injury or contamination of the battery compartment and surrounding area may result.

### Use only the specified batteries.

- If incorrect or different kind of batteries are used, they may explode or leak, and fire, injury or contamination of the battery compartment and surrounding area may result.

### Do not mix old and new batteries.

- If the batteries are inserted incorrectly, they may explode or leak, and fire, injury or contamination of the battery compartment and surrounding area may result.

### Remove the used batteries from the remote control promptly.

- If you leave used batteries in the remote control for an extended period of time, it may cause liquid leaking, abnormal internal temperature rising or explosion.

### If not using the projector for an extended period of time, disconnect the mains plug from the mains socket and remove the batteries from the remote control.

- If dust builds up on the mains plug, the resulting humidity may damage the insulation, which could result in fire.
- Keeping or leaving the remote control with batteries inside may cause insulation deterioration, electrical leakage or explosion which could result in fire.

We are constantly making efforts to preserve and maintain a clean environment. Please take non repairable units back to your dealer or a recycling company.

### Do not put your weight on this projector.

- You could fall or the projector could break, and injury may result.
- Be especially careful not to let young children stand or sit on the projector.

### Disconnect the mains plug from the mains socket as a safety precaution before carrying out any cleaning.

- Electric shocks can result if this is not done.

### If the lamp has broken, ventilate the room immediately. Do not touch or bring your face close to the broken pieces.

- Failure to observe this may cause the user to absorb the gas which was released when the lamp broke and which contains nearly the same amount of mercury as fluorescent lamps, and the broken pieces may cause injury.
- If you believe that you have absorbed the gas or that the gas has got into your eyes or mouth, seek medical advice immediately.
- Ask your dealer about the replacement of the lamp unit and check the inside of the projector.

### Ask an Authorised Service Centre to clean inside the projector at least once a year.

- If dust is left to build up inside the projector without being cleaned out, it can result in fire or problems with operation.
- It is a good idea to clean the inside of the projector before the season for humid weather arrives. Ask your nearest Authorised Service Centre to clean the projector when required. Please discuss with the Authorised Service Centre regarding cleaning costs.

## Cautions when transporting

### Do not subject the projector to excessive vibration or shocks.

- The projector lens need to be handled with care.
- Cover the lens with the lens cover when transporting the projector.

### When you move the projector, hold the body at the bottom securely.

- Do not hold the adjuster legs or the leg adjuster buttons when move the projector, as this may cause damage.

### When transporting, keep the projector in the provided carrying bag.

- Make the lens of the projector upward direction and put it gently into the carrying bag.
- In the carrying bag, the elongated adjuster legs must be housed.
- Do not put anything other than the projector and its accessories in the carrying bag.

## Cautions when installing

### Avoid setting up in places which are subject to vibration or shocks.

- The internal parts can be damaged, which may cause malfunctions or accidents.

### Avoid setting up in places which are subject to sudden temperature changes, such as near an air conditioner or lighting equipment.

- The life of the lamp may be shortened or the projector may be turned off. See "TEMP indicator" on page 41.

### Do not set up the projector near high-voltage power lines or near motors.

- The projector may be subject to electromagnetic interference.

### If installing the projector to the ceiling, ask a qualified technician to carry out all installation work.

- You will need to purchase the separate installation kit. Furthermore, all installation work should only be carried out by a qualified technician.

### If using this projector at high elevations, 1 400 - 2 700 m (4 593 - 8 858 ft) sea level, set the ALTITUDE to HIGH. See "ALTITUDE" on page 37.

- Failure to observe this may result in malfunctions or the life of the lamp or the other components may be shortened.
- Do not use the projector at high elevation higher than 2 700 m (8 858 ft).

## Cautions on use

### In order to get the best picture quality

- Draw curtains or blinds over any windows and turn off any lights near the screen to prevent outside light or light from indoor lamps from shining onto the screen.

### Optical components

- If you use the projector consecutively 6 hours every day, the optical components may need to be replaced in less than 1 year.

### Liquid crystal panel

- Do not project the same image for long periods of time, as this may remain as an afterimage on the liquid crystal panel. Display the white screen test pattern for more than an hour to remove it. See "TEST PATTERN" on page 38.
- The liquid crystal panel of the projector is built with very high precision technology to provide fine picture details. Occasionally, a few stuck pixels may appear on the screen as fixed points of blue, green or red. It is recommended to switch off the projector once and try after 1 hour later again. Please note that this does not affect the performance of your LCD.

### The projector has a high pressure mercury lamp and that is characterised as follows:

- The brightness of the lamp depends on the duration of use.
- The lamp may explode or shorten the lamp life by shocks or chipping damage.
- The lamp may explode only occasionally after using the projector.
- When the lamp exploded, it emits the internal smoke-like gas.
- The lamp may explode if using the projector after the instructed lamp replacement timing.
- The lamp life is depends on individual lamp characteristics, usage condition and the installation environment. Especially the consecutive use of the projector for more than 10 hours, or the frequent switching on or off may greatly affect on the lamp life.

### Do not touch the surfaces of the lens cover with your bare hands.

- If the surface of the lens cover becomes dirty from fingerprints or anything else, this will be magnified and projected onto the screen.

## Security

### Take safety measures for use of the projector which should cover the following envisioned incidents.

- The leakage of your personal registered information.
- Dishonest operation by an untrusted third party.
- Locking out or prevent anyone else from using the projector by an untrusted third party.



### Security instruction

- Change your password regularly.
- Do not use too simple password to guess.
- Any of Authorised Service Centres will never ask you for the password.
- Do not share your password with the general public.
- Secure the network environment by the firewall.

## Precautions with regard to safety

### Accessories

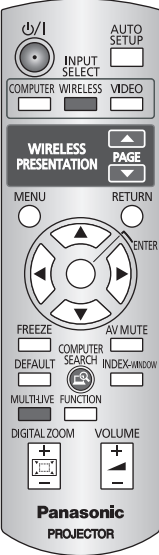
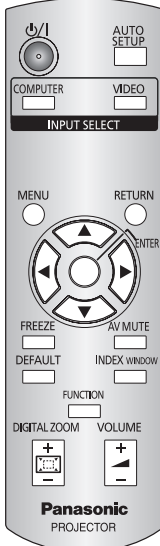
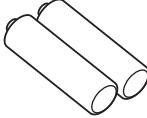
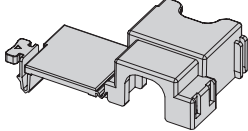
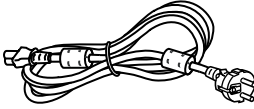
Make sure the following accessories are provided with your projector.

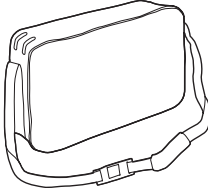
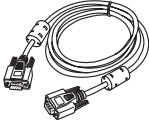
<p>Remote control for PT-LB80NTE / LB75NTE (x1)<sup>*1</sup> N2QAYB000260</p> 	<p>Remote control for PT-LB80E / LB78E / LB75E (x1)<sup>*2</sup> N2QAYB000262</p> 	<p>AA batteries for Remote control (x2)</p> 	<p>Power cord secure lock (x1) TTRA0185</p> 
		<p>Mains lead (x1) K2CM3DR00004</p> 	<p>CD-ROM<sup>*3</sup> (x1) TQBH9011</p> 
		<p>Carrying bag (x1) TPEP021</p> 	<p>RGB signal cable (x1) 1.8 m (5'10") K1HA15DA0002</p> 

\*1. PT-LB80NTE / PT-LB75NTE only

\*2. PT-LB80E / PT-LB78E / PT-LB75E only

\*3. PT-LB80NTE / PT-LB75NTE only

\* The protectors for enclosed products, such as a plug cover or foam cartons, must be treated properly.

\* Contact to an Authorised Service Centre for lost accessories.

# Read this first

## Minimum required setting screen

When you start the projection for the first time or after the projector is initialised, the minimum required setting screen for projection will be displayed.

### LANGUAGE

Select the required language setting.

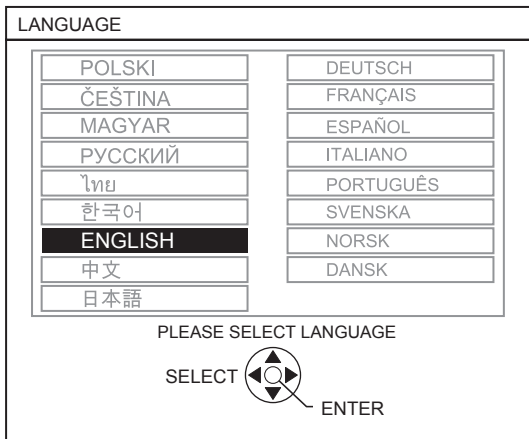

Press ▲ ▼ ◀ ▶ buttons of the remote control or control panel on the projector to highlight the required language, and press the **ENTER** button to proceed to the next setting.

### OPTION

Select the current projection method and fan speed setting. If you need return to the previous setting, press the **RETURN** button.

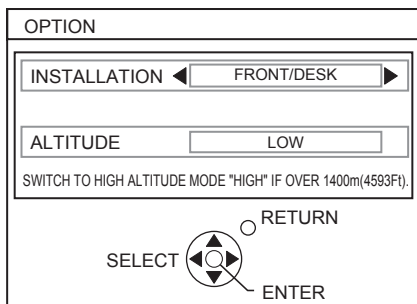

**Press the ENTER button to start the projection.**

- Once you finish the minimum requirement setting, it will not be displayed again unless the projector is initialised. See "INITIALIZE ALL" on page 38.
- You can change each settings in the main menu. See "Menu Navigation" on page 29.

### INSTALLATION

Press ◀ ▶ buttons of the remote control or control panel on the projector to select the required installation method. Press ▼ to proceed to the **ALTITUDE** setting.

<b>FRONT/DESK</b>	Setting on a desk/floor and projecting from front
<b>FRONT/CEILING</b>	Mounting in the ceiling and projecting from front
<b>REAR/DESK</b>	Setting on a desk/floor and projecting from rear
<b>REAR/CEILING</b>	Mounting in the ceiling and projecting from rear

### ALTITUDE

If you use the projector at high elevation, the **ALTITUDE** setting need to be **HIGH** to set the fan speed high. Press ◀ ▶ to select the required option. If you need to return to the **INSTALLATION**, press ▲.

- **LOW** The fan speed is low.
- **HIGH** The fan speed is high.

### NOTE:

- At 1 400 - 2 700 m (4 593 - 8 858 ft) sea level, the setting must be **HIGH**.
- The loudness of fan noise depends on the **ALTITUDE** setting.

# About Your Projector

## Projector body

### Top and front view

#### Zoom-Focus ring cover

Cover the zoom and focus rings to protect from dust.

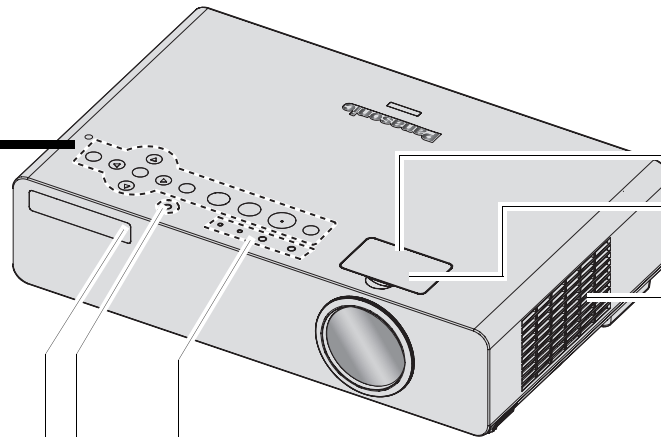
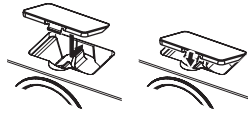

**Zoom ring**  
(page 24)

**Focus ring**  
(page 24)

**Air intake port**

#### Indicators

- **POWER LOCK** indicator (page 23)
- **POWER** indicator (page 23)
- **LAMP** indicator (page 41)
- **TEMP** indicator (page 41)

**Ambient Luminance Sensor (ALS)**  
(page 32)

**Remote control signal receptor**  
(page 25)

#### RELEASE button

Press to release the locked **POWER** button when turning on the projector. (page 21)

#### POWER button

Switch between stand-by mode and projection mode. (page 21/ page 22)

#### Navigation buttons

Navigate through the menus with **▲▼◀▶**, and activate the menu item with **ENTER**. (page 29)

### Control panel

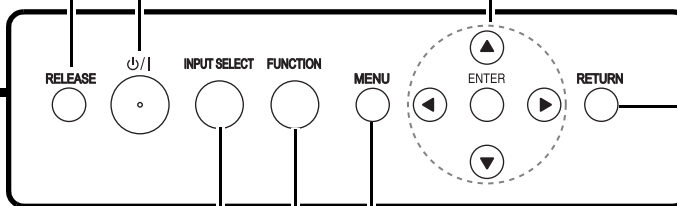

#### RETURN button

Return to the previous menu. (page 29)

#### INPUT SELECT button

Switch to cycle through the input method. (page 24)

**COMPUTER1**→**COMPUTER2**→**S-VIDEO**→**VIDEO**→**WIRELESS**→**COMPUTER1**

#### MENU button

Display the main menu. (page 29)

#### FUNCTION button

Assign a useful function for shortcut. (page 27)

### NOTE:

- Do not cover the ventilation openings or place anything within 50 cm (20") of them as this may cause damage or injury.

**Back and bottom view**

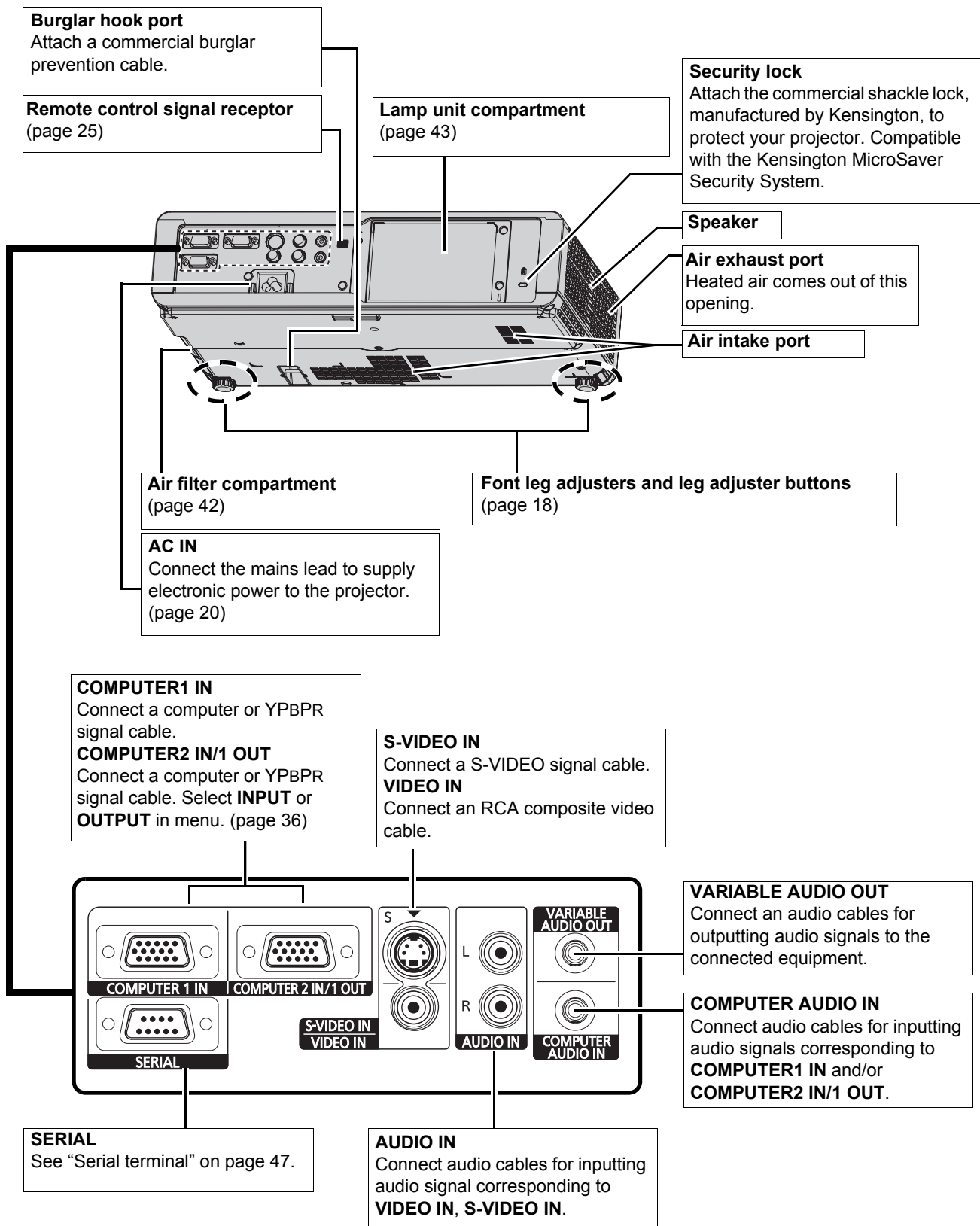

**NOTE:**

- Do not cover the ventilation openings or place anything within 50 cm (20") of them as this may cause damage or injury.
- When a cable is connected to the **VARIABLE AUDIO OUT**, the built-in speaker will be disabled.



# About Your Projector

## Remote control

Preparation

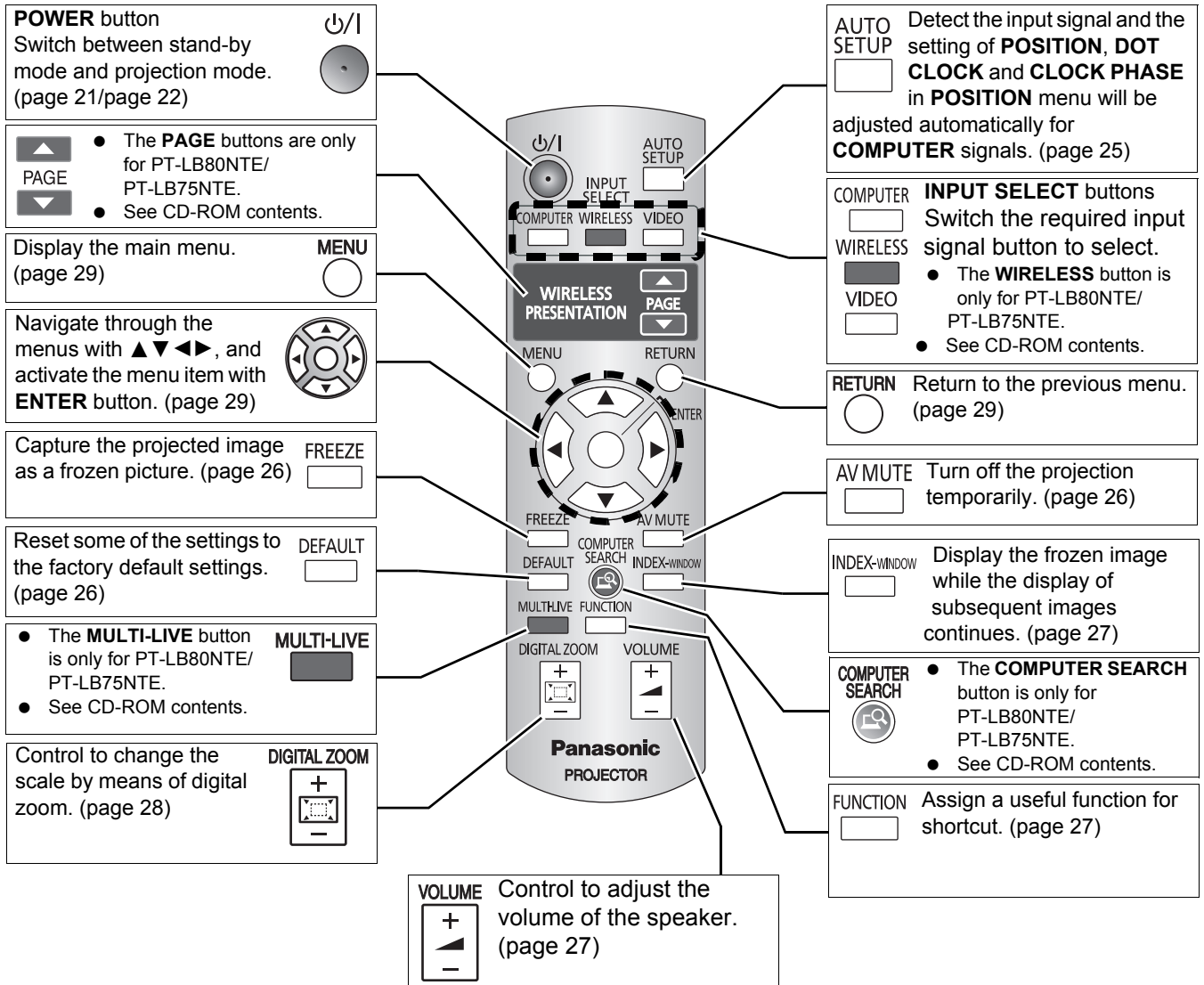

### Battery compartment

1. Press the tab and lift up the cover.
2. Insert the batteries according to the polarity diagram indicated inside.



### Top view (page 25)

Remote control signal emitters

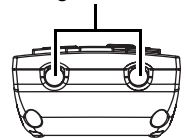

### Attaching a hand strap

You can attach a favourite strap on to the remote control.

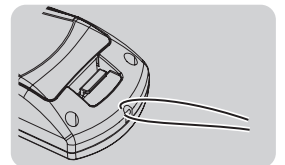

### NOTE:

- Do not drop the remote control.
- Avoid contact with liquids or moisture.
- Use manganese batteries or alkaline batteries with the remote control.
- Do not attempt to modify or disassemble the remote control. Contact an Authorised Service Centre for repairs.
- Do not keep pressing the remote control buttons as this may shorten battery life.
- See "Remote control operation" on page 25.

# Setting up

## Screen size and throw distance

You can adjust the projection size with 1.2x zoom lens. Calculate and define the throw distance as follows.

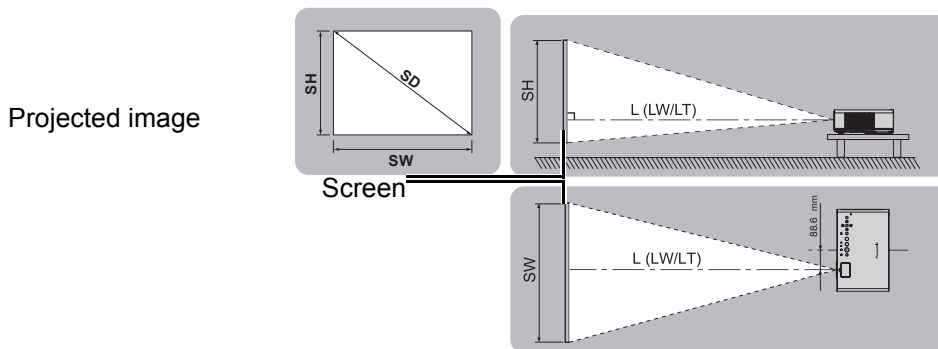

Projection size (4 : 3)	Throw distance (L) PT-LB80NTE / LB80E		Throw distance (L) PT-LB78E / LB75NTE / LB75E	
	Minimum distance (LW)	Maximum distance (LT)	Minimum distance (LW)	Maximum distance (LT)
33" (0.84 m)		1.1 m (3'7")		1.1 m (3'7")
40" (1.02 m)	1.1 m (3'7")	1.4 m (4'7")	1.1 m (3'7")	1.4 m (4'7")
50" (1.27 m)	1.4 m (4'7")	1.7 m (5'6")	1.4 m (4'7")	1.7 m (5'6")
60" (1.52 m)	1.7 m (5'6")	2.1 m (6'10")	1.7 m (5'6")	2.1 m (6'10")
70" (1.78 m)	2.0 m (6'6")	2.5 m (8'2")	2.0 m (6'6")	2.4 m (7'10")
80" (2.03 m)	2.3 m (7'6")	2.8 m (9'2")	2.3 m (7'6")	2.8 m (9'2")
90" (2.29 m)	2.6 m (8'6")	3.2 m (10'5")	2.6 m (8'6")	3.1 m (10'2")
100" (2.54 m)	2.9 m (9'6")	3.5 m (11'5")	2.9 m (9'6")	3.5 m (11'5")
120" (3.05 m)	3.5 m (11'5")	4.2 m (13'9")	3.5 m (11'5")	4.2 m (13'9")
150" (3.81 m)	4.4 m (14'5")	5.3 m (17'4")	4.3 m (14'1")	5.2 m (17')
200" (5.08 m)	5.9 m (19'4")	7.1 m (23'3")	5.8 m (19')	7.0 m (22'11")
250" (6.35 m)	7.4 m (24'3")	8.9 m (29'2")	7.3 m (23'11")	8.7 m (28'6")
300" (7.62 m)	8.8 m (28'10")	10.7 m (35'1")	8.7 m (28'6")	10.5 m (34'5")

\* All measurements above are approximate and may differ slightly from the actual measurements.

### Calculation methods for screen dimensions

You can calculate more detailed screen dimension from the screen diagonal.

- Screen width (SW) and screen height (SH)

$$SW (m) = SD (") \times 0.0203$$

$$SH (m) = SD (") \times 0.0152$$

- Minimum distance (LW) and maximum distance (LT)

$$PT-LB80NTE: LW (m) = 0.0296 \times SD (") - 0.039$$

$$LT (m) = 0.0358 \times SD (") - 0.047$$

$$PT-LB75NTE: LW (m) = 0.0292 \times SD (") - 0.036$$

$$LT (m) = 0.0351 \times SD (") - 0.044$$

\* The results above are approximate and may differ slightly from the actual measurements.

#### NOTE:

- See "Screen size and throw distance for 16:9 aspect ratio" on page 49.
- Do not use the projector at a raised or a horizontally tilted position as it may cause malfunction of the projector.
- You can tilt the projector body approximately  $\pm 30^\circ$  vertically. Overtilting may result in shortening the component's life.
- For the best quality of the projection image, install a screen where sun light or room light does not shine directly onto the screen. Close window shades or curtains to block the lights.

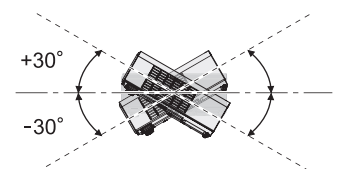

## Setting up

### Projection method

You can use the projector with any of the following 4 projection methods. To set the desired method in the projector, See "INSTALLATION" on page 37.

#### ■ Setting on a desk/floor and projecting from front

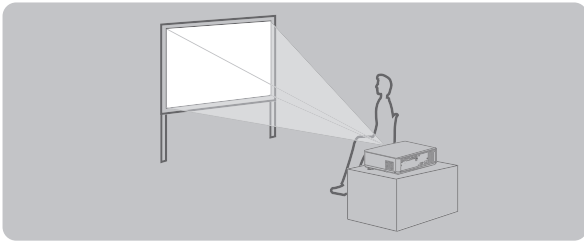

INSTALLATION: FRONT/DESK

#### ■ Setting on a desk/floor and projecting from rear

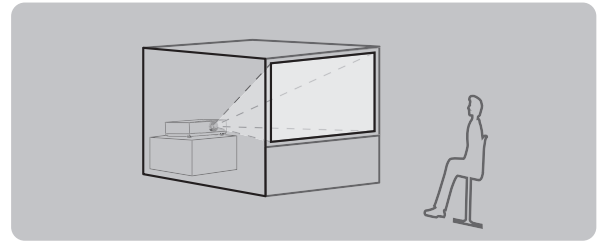

INSTALLATION: REAR/DESK

#### ■ Mounting in the ceiling and projecting from front

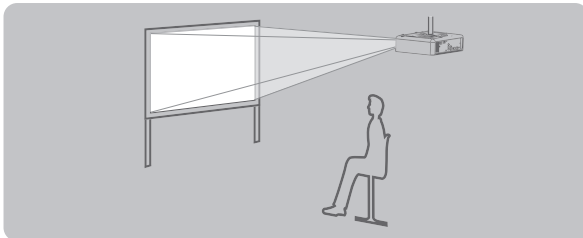

INSTALLATION: FRONT/CEILING

#### ■ Mounting in the ceiling and projecting from rear

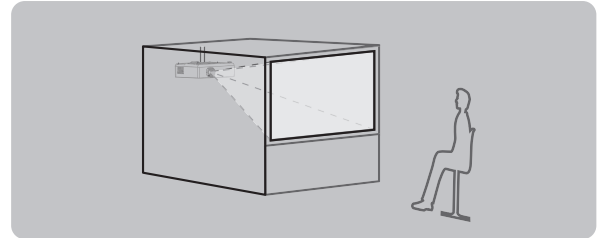

INSTALLATION: REAR/CEILING

#### NOTE:

- A translucent screen is required for rear projection.
- When mounting the projector in the ceiling, the optional ceiling mount bracket (ET-PKB80) is required.

### Front leg adjusters and throwing angle

You can adjust the projection angle in the vertical direction by pressing the leg adjuster buttons. See "Positioning the image" on page 24.

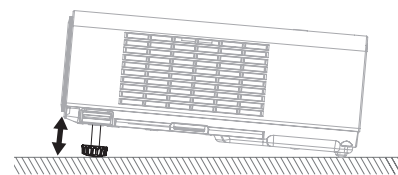
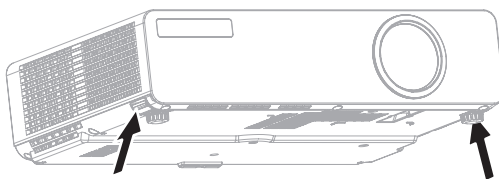

#### NOTE:

- Heated air comes out of the air exhaust port. Do not touch the air exhaust port directly.
- If keystone distortion occurs, see "KEYSTONE" on page 34.

# Connections

## Before connection to the projector

- Read and follow the operating and connecting instructions of each peripheral device.
- The peripheral devices must be turned off.
- One RGB cable is provided with the projector. If necessary, prepare commercial connecting cables that match with the projector and each peripheral device terminals.
- If the input signal is affected by signal jitter, the projected image may have poor image quality and timebase correction is effective.
- Confirm the type of video signals. See “List of compatible signals” on page 46.
- When you connect more than one AV equipment, switch the audio connection manually.

## Connecting example: AV equipment

### Connecting with VIDEO IN/S-VIDEO IN

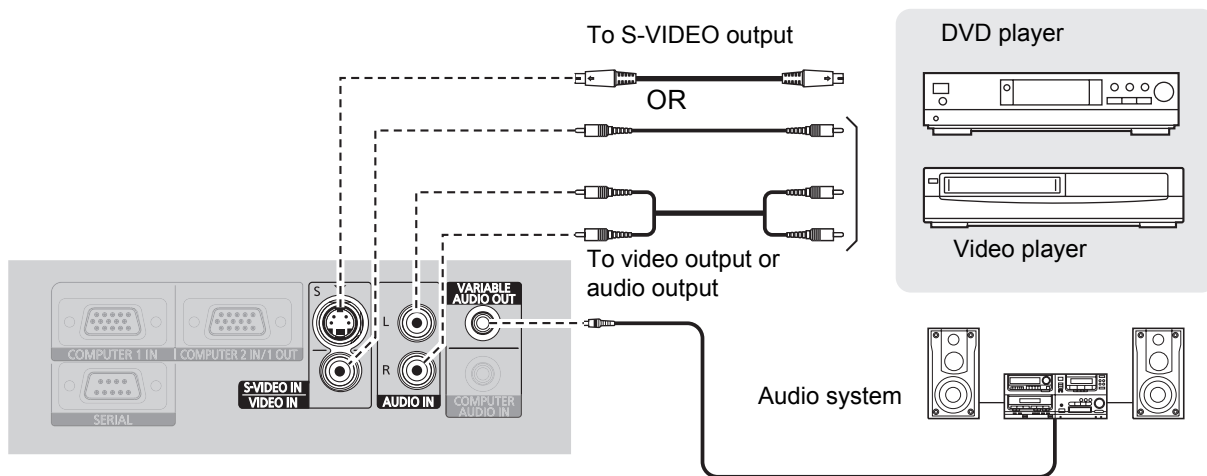

## Connecting example: Computers

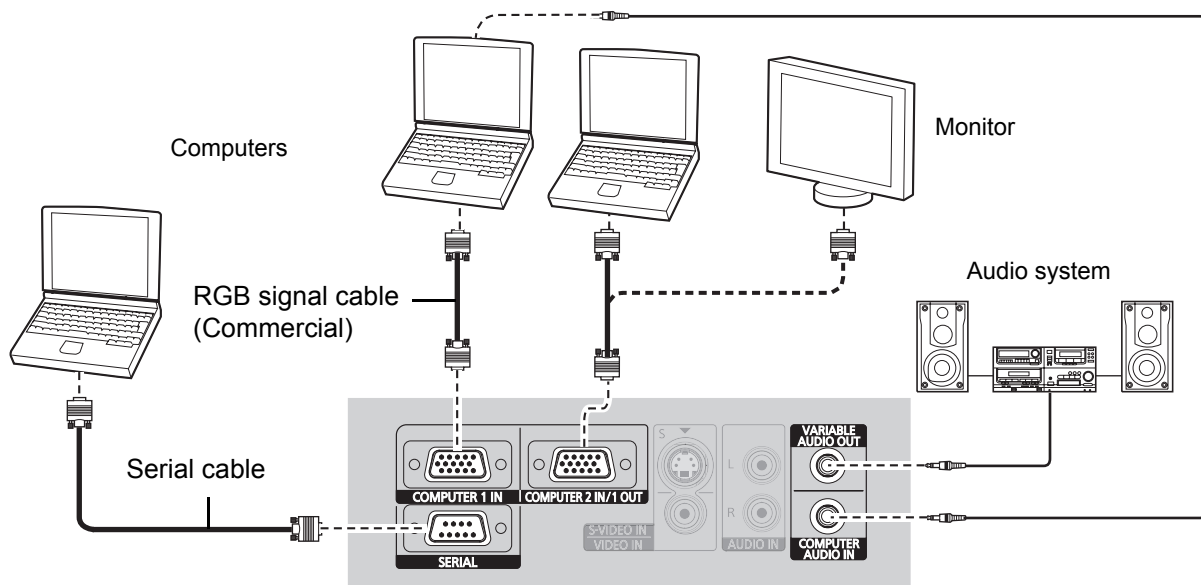

### NOTE:

- When **COMPUTER2 SELECT** in the **OPTION** menu is set to **OUTPUT**, do not connect any input signals.
- Outputting signals from the **COMPUTER 1 OUT** terminal to multi connected device(s) may result in signal deterioration.
- See CD-ROM contents for the wireless connection. (PT-LB80NTE/PT-LB75NTE only)

# Switching the projector on/off

## Mains lead

### Connecting

1. Make sure the shape of the mains plug and the **AC IN** terminal on the back of the projector match, then push the plug all the way in.

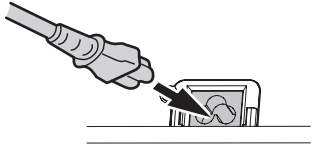

2. Align the side of the power cord secure lock with the side guide rail of the **AC IN** terminal of the projector and slide it in.

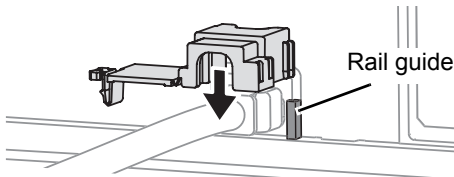

3. Place the latch to the latch catcher and press until it clicks.

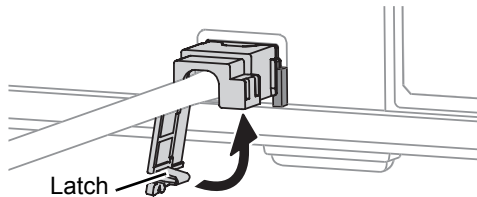

4. Connect the mains lead to a mains socket.
5. The **POWER** and **POWER LOCK** indicators light in red and the projector stays in standby mode.

### Direct power on function

If the **DIRECT POWER ON** in **OPTION** menu is set to **ON**, connect the mains lead to a mains socket and the projection will start even when the control panel is disabled or the **POWER** button is locked. See "DIRECT POWER ON" on page 37.

If the **DIRECT POWER ON** is set to **OFF**, the projector will be at the same mode as last unplugged, standby mode or projection mode.

### Disconnecting

1. Unplug the mains lead from the mains socket.
2. Depress the latch and slide the cover off.

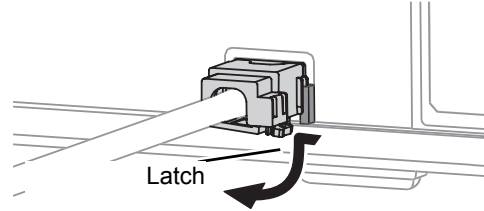

3. Slide the power cord secure lock up along the side guide rail and remove.

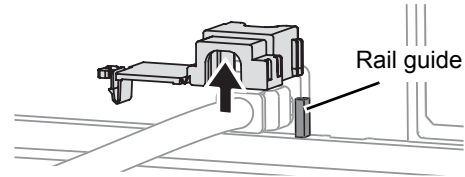

4. Hold the plug and unplug the mains lead from the **AC IN** terminal on the back of the projector.
  - **POWER** indicator lights in orange if the internal cooling fan is still operating by internal power supply.

### Direct power off function

You can switch off the electric power supply any time by unplugging the mains plug from the mains socket or by switching off the main power. The internal lamp cooling fan keeps operating by the internal power supply, and stops automatically when cooled enough.

#### NOTE:

- Do not use other than a provided mains lead.
- Ensure all the input devices are connected and turned off before connecting the mains lead.
- Do not force the connector as this may damage the projector and/or the mains lead.
- Dirt or dust build-up around plugs may cause fire or electrical hazards.
- Switch off the power to the projector when not in use.
- If the projector is switched on again while the internal cooling fan is still operating by the internal power supply, it may take a while to start the projection.
- Do not put the projector into the carrying bag with the **POWER** indicator lit.

## Switching on the projector

Before switching on the projector, make sure the mains lead and all the other devices are connected correctly. See “Connections” on page 19 and “Mains lead” on page 20.

### ● By control panel operation

Make sure **CONTROL PANEL** in **OPTION** menu is set to **VALID**. The **POWER** button is locked to prevent malfunction and the **POWER LOCK** indicator lights in red.

1. Press the **RELEASE** button.
  - The **POWER LOCK** indicator goes off.
  - Without any operation in 10 seconds, the **POWER** button will be locked again.
2. Press the **POWER** button in 10 seconds.
  - The **POWER** button beeps once.
3. The **POWER** indicator flashes in green several times.
4. The **POWER** indicator lights in green and displays the startup logo for 30 seconds.
  - When the **STARTUP LOGO** in **OPTION** menu is set to **OFF**, the startup logo will not be displayed. See “STARTUP LOGO” on page 36.

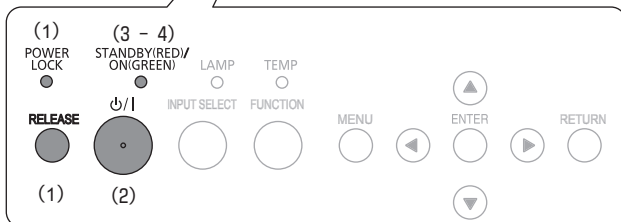
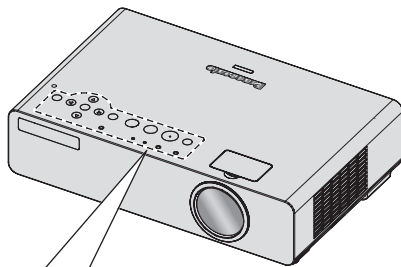

### ● By remote control operation

1. Press the **POWER** button.
2. The **POWER** indicator flashes in green several times.
3. The **POWER** indicator lights in green and displays the startup logo for 30 seconds.
  - When the **STARTUP LOGO** in **OPTION** menu is set to **OFF**, the startup logo will not be displayed. See “STARTUP LOGO” on page 36.

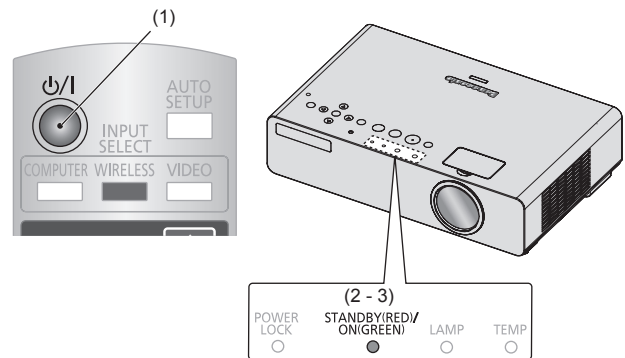

### ● By direct power on function

You can switch on the projector by connecting the mains lead. See “Direct power on function” on page 20.

### NOTE:

- When starting up the projector, some small rattling or tinkling sound may be heard, or the display may flicker for the characteristics of the lamp. Those are normal and will not affect the performance of the projector.
- When the internal cooling fan is operating, some, operational sound may be heard. The loudness of the operational sound depends on the external temperature.
- If the projector is switched on again while the internal cooling fan is still operating by the internal power supply, it may take a while to start the projection.
- Operating the control panel buttons with covered hand, such as plastered or gloved, may result in fail.

## Switching the projector on/off

### Switching off the projector

#### By control panel operation

Make sure the **CONTROL PANEL** setting in **OPTION** menu is set to **VALID**.

1. Press the **POWER** button.
  - The confirmation screen will be displayed.
  - Without any operation for 10 seconds or press any button other than the **POWER** button, the confirmation screen will go off and return to the projection.
2. Press the **POWER** button again in 10 seconds.
3. The **POWER** indicator will flash in orange.
  - The projector is cooling the lamp.
4. The **POWER** and **POWER LOCK** indicator switch to red.

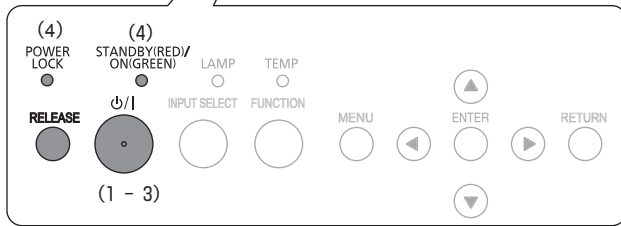
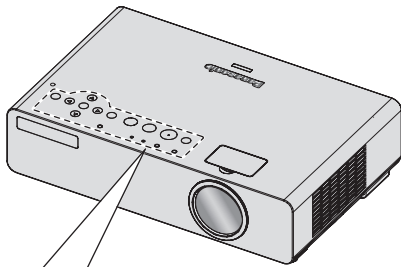

#### By remote control operation

1. Press the **POWER** button.
  - The confirmation screen will be displayed.
  - Without any operation for 10 seconds or press any button other than the **POWER** button, the confirmation screen will go off and return to the projection.
2. Press the **POWER** button again in 10 seconds.
3. The **POWER** indicator will flash in orange.
  - The projector is cooling the lamp.
4. The **POWER** and **POWER LOCK** indicator light red.

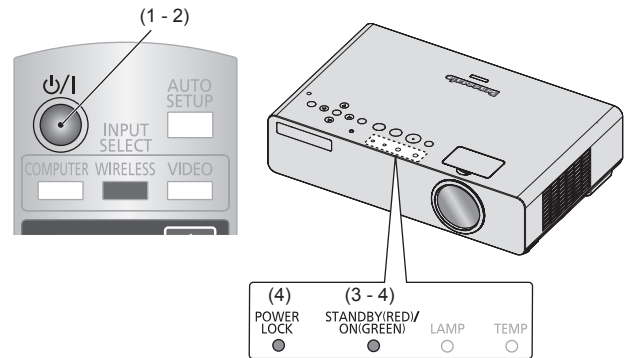

#### By direct power off function

You can switch off the projector by disconnecting the mains lead. See "Direct power off function" on page 20.

#### NOTE:

- You can switch off the power without displaying the confirmation screen by pressing the **POWER** button for longer than 0.5 second.
- When the internal cooling fan is operating, some, operational sound may be heard. The loudness of the operational sound depends on the external temperature.
- If the projector is switched on again while the internal cooling fan is still operating by the internal power supply, it may take a while to start the projection.
- Operating the control panel buttons with covered hand, such as plastered or gloved hand, may result in fail.



## POWER and POWER LOCK indicators

The **POWER** indicator informs you the status of the power and the **POWER LOCK** indicator shows the status of the **RELEASE** button.

- When the **LAMP** and/or **TEMP** indicators are flashing, the **POWER** and **POWER LOCK** indicators will not light.

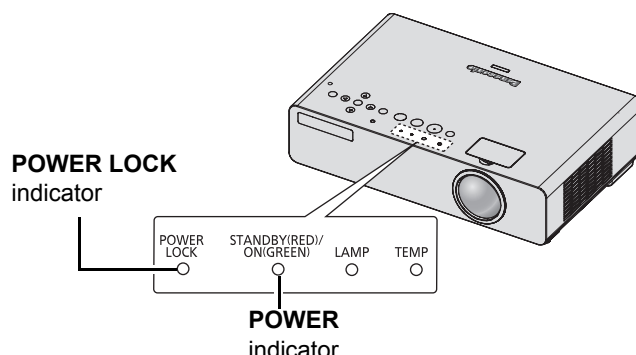

### POWER LOCK indicator status

Indicator status		Status
No illumination or flashing		<ul style="list-style-type: none"> <li>No power is supplied.</li> <li>The <b>RELEASE</b> button is pressed and the <b>POWER</b> button is unlocked.</li> <li>The power is on.</li> </ul>
Red	Lit	The <b>POWER</b> button is locked.
	Flashing	Pressing the locked <b>POWER</b> button.

### POWER indicator status

Indicator status		Status
No illumination or flashing		No power is supplied and the internal cooling fan is not operating.
Red	Lit	The power is supplied and in standby mode*1, and the <b>POWER</b> button is locked.
	Flashing	Network connection standby: Only when <b>NETWORK STANDBY</b> in <b>NETWORK</b> menu is <b>ON</b> . (PT-LB80NTE/PT-LB75NTE only)
Green	Flashing	The power is on and preparing for projection.
	Lit	Projecting.
Orange	Lit	No power supply and the internal fan is cooling the lamp by internal power supply.
	Flashing	The power is switched on again while cooling the lamp and recovering to the projection mode. Recovery may take a while.

\*1. The electric consumption in standby mode is 4.0 W.



# Projecting an image

## Selecting the input signal

1. Switch on the connected devices.
  - Press the play button of the required device.
2. Detect the input signal automatically.
3. Switch the aspect ratio automatically.

### NOTE:

- If the **SIGNAL SEARCH** in **OPTION** menu is deactivated, select the required input method by pressing the **INPUT SELECT** buttons of the remote control or the **INPUT SELECT** button of the projector several times. See "SIGNAL SEARCH" on page 37, "Switching the input signal" on page 26 or "INPUT SELECT button" on page 14.
- See "ASPECT" on page 34.

## Positioning the image

1. Place the projector at the right angle from the screen.



2. Adjust the vertical angle of the projector.
  - Press the front leg adjuster buttons and adjust the vertical angle.
  - See "Front leg adjusters and throwing angle" on page 18.

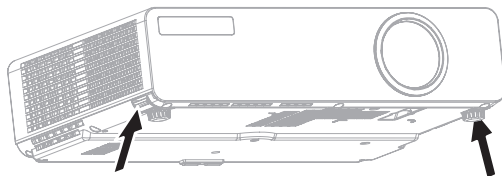

3. Open the Zoom-Focus ring cover.
  - See "Zoom-Focus ring cover" on page 14.

4. Turn the zoom and focus rings to adjust the projected image.

- You can confirm the adjusted effect with the **TEST PATTERN** in **OPTION** menu. See "TEST PATTERN" on page 38.

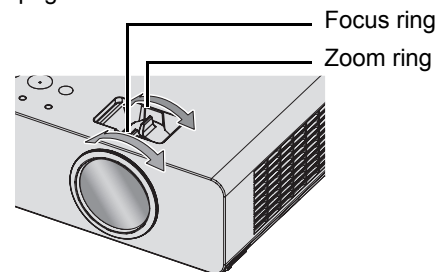

5. Close the Zoom-Focus ring cover.
  - See "Zoom-Focus ring cover" on page 14.

### NOTE:

- Do not touch the air exhaust port as this may cause burns or injury.
- If keystone distortion occurs, see "KEystone" on page 34.
- When you adjust the zoom after adjusting the focus, you may need to adjust the focus of the image again.

# Remote control operation

## Operating range

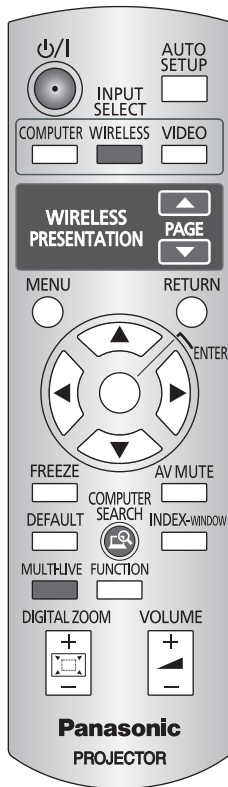

You can operate the projector with the remote control within the remote range 15 m (49'2"), approximately  $\pm 30^\circ$  vertically and horizontally.

### ● Facing to the projector

Make sure the remote control emitter is facing to the remote control signal receptor of the projector when pressing the buttons to operate.

### ● Facing to the screen

Make sure the remote control emitter is facing to the screen when pressing the buttons to operate the projector. The signal will be reflected off the screen to the projector.

- The operating range may differ due to the screen material, and this function may not be effective with a translucent screen.

### NOTE:

- See "About Your Projector" on page 14 to confirm the position of the remote control signal emitter and receptor.
- Do not let strong light shine onto the signal receptor. The remote control may malfunction under strong light such as fluorescent.
- If there are any obstacles between the remote control emitter and the remote control signal receptor, the remote control may not operate correctly.

## Setting up the image position automatically

If you need to readjust the projected image position while projecting or when **AUTO SETUP** in **OPTION** menu is set to **BUTTON**, press the **AUTO SETUP** button.

The projector will detect a RGB signal by **SIGNAL SEARCH** system and adjust the setting of **POSITION**, **DOT CLOCK** and **CLOCK PHASE** in **POSITION** menu automatically.

### NOTE:

- If **SIGNAL SEARCH** setting in **OPTION** menu is set to **OFF**, select the required signal manually first. See "Switching the input signal" on page 26.
- If the dot clock frequency is 108 MHz or higher, **AUTO SETUP** is not effective.
- If the projected image is too dark or blurred around the edge, **AUTO SETUP** may stop the processing before complete the adjustment and return to the previous setting. Project a much clearer or lighter image and try again.

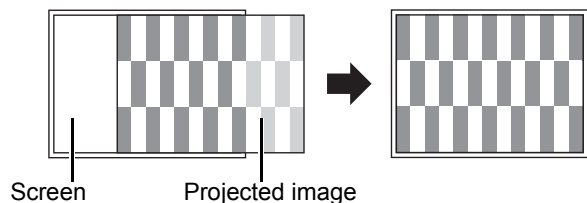

## Remote control operation

### Switching the input signal

**COMPUTER**

**WIRELESS**

**VIDEO**

You can switch the input method manually by pressing the **COMPUTER**, **WIRELESS** (PT-LB80NTE/PT-LB75NTE only) and **VIDEO** buttons. Press the required button several times or ◀ ▶ to cycle through the input methods as follows.

- You can confirm the selected input method in displayed graphical input guide on the upper right of the screen. Highlighted in yellow is selected terminal. See "INPUT GUIDE" on page 36.

#### ● Pressing the **COMPUTER** button



#### NOTE:

- Only when the **COMPUTER2 SELECT** is set to **INPUT**, you can switch between **COMPUTER1** and **COMPUTER2**.
- With no signals from **COMPUTER** terminals, the computer connecting guidance will be displayed. See "Computer connection guidance" on page 48.

#### ● Pressing the **WIRELESS** button

- The **WIRELESS** button is only for PT-LB80NTE/PT-LB75NTE.
- See CD-ROM contents for more detailed information.

#### ● Pressing the **VIDEO** button



#### ● Pressing the **INPUT SELECT** button on the projector

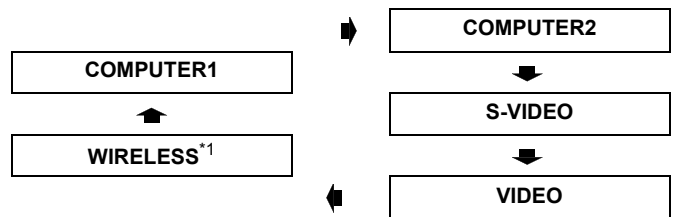

\*1. **WIRELESS** is only for PT-LB80NTE/PT-LB75NTE.

#### NOTE:

- Switched signal may be displayed after a short interval.
- If you select an unplugged input method, the input guidance will blink on and off several times.
- See "List of compatible signals" on page 46.
- See "Connections" on page 19.

### Capturing an image

**FREEZE**

Press the **FREEZE** button to capture the image and you can see it as a still picture. While the image is frozen, the audio sound through the

projector will stop. Press the **FREEZE** button again to escape and return to the continuing image.

### Stopping the projection temporary

**AV MUTE**

You can stop the projection and audio sound through the projector temporarily for saving

electrical power. Press the **AV MUTE** button again to escape.

### Resetting to the factory default settings

**DEFAULT**

You can reset most of the customised settings to the factory defaults by pressing the **DEFAULT** button of the remote control. Display the required sub menu or the menu items and press the **DEFAULT** button again.

- See "Main menu and Sub-menu" on page 30.

#### NOTE:

- Some menu items are not available to reset by pressing the **DEFAULT** button. Adjust each menu items manually.
- To reset all the settings to the factory defaults, see "INITIALIZE ALL" on page 38.

## Projecting an image in INDEX-WINDOW mode

**INDEX-WINDOW**  
 You can project an image split in 2 windows as an **INDEX-WINDOW**. One is frozen and stored in memory, and displayed on the screen's left side while displaying subsequent image continues on the right. Press the **MENU** or **RETURN** button to escape.

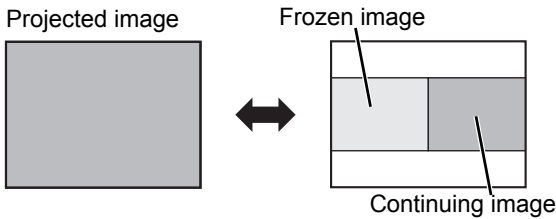

### ● Switching the position

In default, the frozen image is displayed on the left and the subsequent image is displayed on the right. Press ◀ ▶ to switch the position.

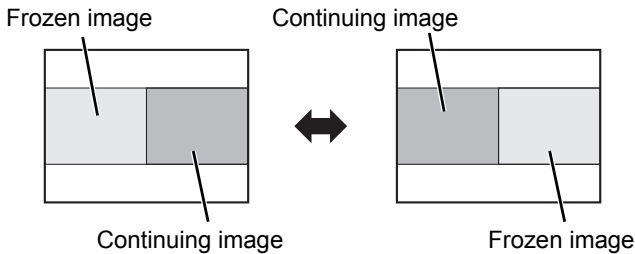

### ● Changing the image size

Press ▲ ▼ to capture a new image and change the size in 3 ways.

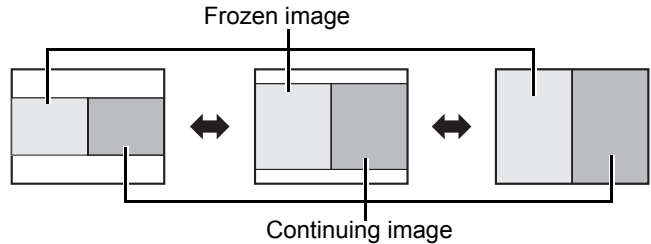

#### NOTE:

- If you change the window size, the aspect ratio of the image is changed and becomes vertically elongated.

### ● Capturing a new image

While in **INDEX-WINDOW** mode, press the **ENTER** button to capture a new image and the frozen image window will be updated in a moment.

#### NOTE:

- When capturing a quick moving picture, perform several times to get a stabled picture.

## Using an assigned function

**FUNCTION**  
 You can assign a selected function to the **FUNCTION** button. Following functions are assignable. See "FUNCTION BUTTON" on page 38 for assigning procedure.

<b>AV MUTE</b>	See "Stopping the projection temporary" on page 26.
<b>FREEZE</b>	See "Capturing an image" on page 26.
<b>AUTO SETUP</b>	See "Setting up the image position automatically" on page 25.
<b>INDEX-WINDOW</b>	See "Projecting an image in INDEX-WINDOW mode" on page 27.
<b>ASPECT</b>	See "ASPECT" on page 34.
<b>PICTURE MODE</b>	See "PICTURE MODE" on page 32.

## Controlling the volume of the speaker

**VOLUME**  
 You can control the volume of the built-in speakers and output audio sound. Press "+" side of the **VOLUME** button to increase and "-" to decrease.

## Enlarging the centred area

### DIGITAL ZOOM



You can enlarge the projected image down to a centred area for emphasizing within the range of 1x to 2x.

### ● Enlarging the image

1. Press any side of the **DIGITAL ZOOM +/-** button once.
  - The centred area of the image will then be enlarged

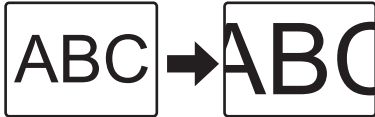

2. Adjust the image size by pressing the **DIGITAL ZOOM +/-** button.
  - Changes the size of the image in steps of 0.1.

Press “-”

Press “+”



### ● Shifting the centre point

Press ▲ ▼ ◀ ▶ to shift the centre point.

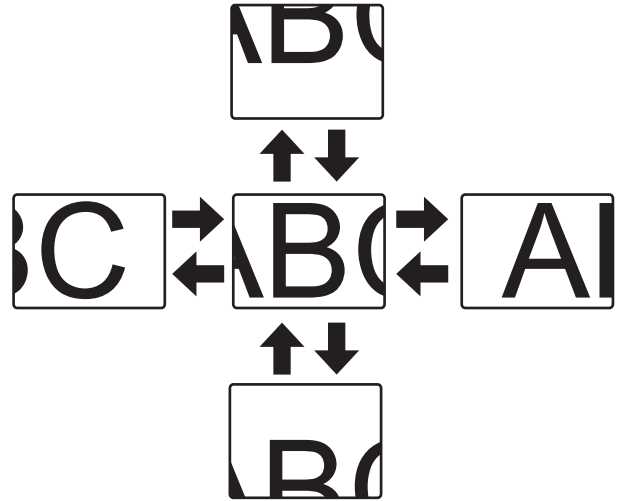

### NOTE:

- When the **COMPUTER** signal is projected, the enlargement range will be changed to 1x to 3x. When the **FRAME LOCK** in **POSITION** menu is set to **ON**, the enlargement range is 1x to 2x. See “FRAME LOCK” on page 35.
- When the input signal is changed while the **DIGITAL ZOOM** is activated, the **DIGITAL ZOOM** will be cancelled.
- While the **DIGITAL ZOOM** is activated, the **AUTO SETUP**, **FREEZE**, **DEFAULT**, **INDEX-WINDOW** and **FUNCTION** (except when **AV MUTE** is assigned) buttons are not available.

# Menu Navigation

The menu system allows you to access functions which do not have their own dedicated buttons on the remote control. The menu options are structured and categorised. You can navigate through the menu with ▲ ▼ ► ◀ buttons.

## Navigating through the MENU

### ■ Displaying the main menu

**MENU** Press the **MENU** button to display the main menu and the operating guidance.

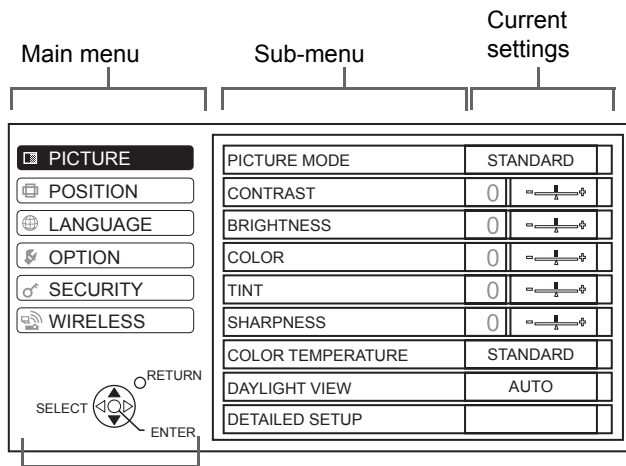

#### Operating guidance

Contains the required buttons to adjust the settings.

### ■ Adjusting with the bar scale items

The triangle mark under the bar indicates factory default setting and the square indicates the current setting.

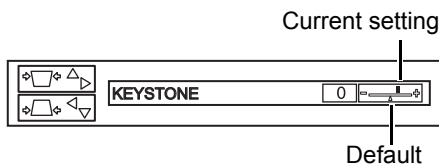

### ■ Returning to the previous menu

**RETURN** Press the **MENU** or **RETURN** button to return to the previous menu. Press repeatedly to escape from the menu mode and return to the projection.



### ■ Operating procedure

1. Press ▲ ▼ to scroll to the required main menu item and press the **ENTER** button to select.
  - The selected item is highlighted in orange and displays the sub-menu on the right.
  - See “Main menu and Sub-menu” on page 30.

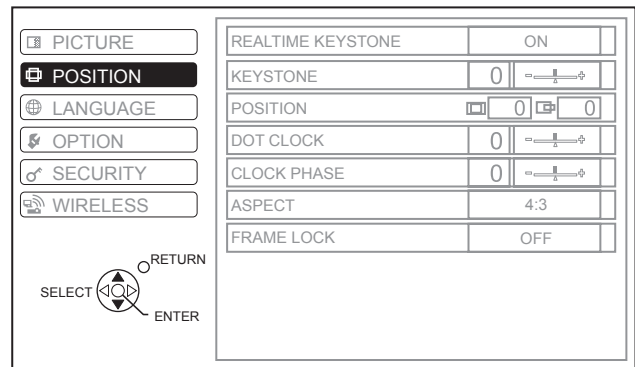

2. Press ▲ ▼ to scroll to the required sub-menu item and press ◀ ► or the **ENTER** button to adjust.
  - The selected item is called up and the other menu items disappear from the screen.
  - If there is a lower level, the next level will be displayed.

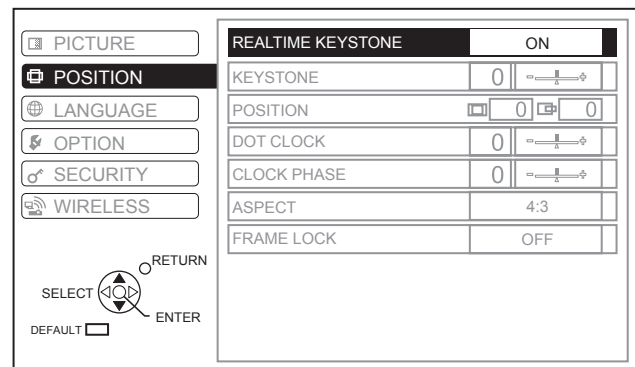

3. Press ◀ ► to adjust the bar scale or select the required option.
  - Called up item will disappear after 5 seconds without any operation and return to the menu mode.
  - For items indicated in bar scale type, the current settings are displayed on the left of the bar.
  - You can cycle through the options of an item by pressing ◀ ►.

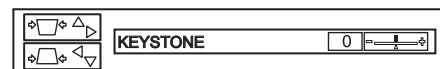

4. Press **MENU** or **RETURN** button to return to the previous menu.

#### NOTE:

- See “Resetting to the factory default settings” on page 26 to reset each menu items.
- See “INITIALIZE ALL” on page 38 to reset all the settings.

# Menu Navigation

## Main menu and Sub-menu

The main menu has 6 options. Select the required menu item and press **ENTER** to display the sub-menu. Underlined items are factory default settings.

### NOTE:

- Some default settings vary by the selected input signal.
- sub-menu items vary according to the selected input signal.
- Some settings are adjustable without any signals.

## PICTURE

<b>PICTURE MODE</b>	page 32
NATURAL DYNAMIC      STANDARD BLACKBOARD	
<b>CONTRAST</b>	page 32
(Default: 0)	
<b>BRIGHTNESS</b>	page 32
(Default: 0)	
<b>COLOR</b>	page 32
(Signals from <b>S-VIDEO/VIDEO</b> only)	
(Default: 0)	
<b>TINT</b>	page 32
(Signals from <b>S-VIDEO/VIDEO</b> only)	
(Default: 0)	
<b>SHARPNESS</b>	page 32
(Default: 0)	
<b>COLOR TEMPERATURE</b>	page 32
STANDARD	
LOW                      HIGH	
<b>DAYLIGHT VIEW</b>	page 32
AUTO	
OFF                      ON	
<b>DETAILED SETUP</b>	page 33
(Not available with wireless connection)	
<b>TV-SYSTEM</b>	
AUTO	
NTSC                      NTSC 4.43	
PAL                      PAL-M	
PAL-N                      SECAM	
<b>STILL MODE</b>	
OFF                      ON	
<b>NOISE REDUCTION</b>	
OFF                      ON	
<b>WHITE BALANCE RED</b>	(Default: 0)
<b>WHITE BALANCE GREEN</b>	(Default: 0)
<b>WHITE BALANCE BLUE</b>	(Default: 0)

## POSITION

<b>REALTIME KEYSTONE</b>	page 34
ON                      OFF	
<b>KEYSTONE</b>	page 34
(Not available with wireless connection)	
(Default: 0)	
<b>POSITION</b>	page 34
(Not available with wireless connection)	
H (Default: 0)      V (Default: 0)	
<b>DOT CLOCK</b>	page 34
(Signals from <b>COMPUTER</b> only)	
(Default: 0)	
<b>CLOCK PHASE</b>	page 34
(Signals from <b>COMPUTER</b> only)	
(Default: 0)	
<b>ASPECT</b>	page 34
(Vary according to the selected input signal)	
AUTO	
4:3                      16:9	
S4:3                      THROUGH	
<b>FRAME LOCK</b>	page 35
(Signals from <b>COMPUTER</b> only)	
OFF                      ON	

## LANGUAGE

	1/2
DEUTSCH	
FRANÇAIS	
ESPAÑOL	
ITALIANO	
PORTUGUÊS	
SVENSKA	
NORSK	
DANSK	
▼	
	2/2
POLSKI	
ČEŠTINA	
MAGYAR	
РУССКИЙ	
ไทย	
한국어	
● ENGLISH	
中文	
日本語	

 **OPTION**

<b>INPUT GUIDE</b>		page 36
<u>DETAILED</u>	SIMPLE	
OFF		
<b>STARTUP LOGO</b>		page 36
ON	OFF	
USER		
<b>COMPUTER2 SELECT</b>		page 36
<u>INPUT</u>	OUTPUT	
<b>RGB/YPbPr</b>		page 36
<u>AUTO</u>	YPbPr	
RGB		
<b>WIDE MODE</b>		page 36
<u>OFF</u>		
ON		
<b>LAMP POWER</b>		page 37
<u>STANDARD</u>	ECO-MODE	
<b>LAMP RUNTIME</b>		page 37
<b>POWER OFF TIMER</b>		page 37
<u>DISABLE</u>		
15 MIN.	20 MIN.	
25 MIN.	30 MIN.	
35 MIN.	40 MIN.	
45 MIN.	50 MIN.	
55 MIN.	60 MIN.	
<b>DIRECT POWER ON</b>		page 37
<u>OFF</u>	ON	
<b>CONTROL PANEL</b>		page 37
<u>VALID</u>	INVALID	
<b>AUTO SETUP</b>		page 37
<u>AUTO</u>	BUTTON	
<b>SIGNAL SEARCH</b>		page 37
<u>ON</u>	OFF	
<b>INSTALLATION</b>		page 37
<u>FRONT/DESK</u>	FRONT/CEILING	
REAR/DESK	REAR/CEILING	
<b>ALTITUDE</b>		page 37
<u>LOW</u>	HIGH	
<b>FUNCTION BUTTON</b>		page 38
<u>AV MUTE</u>	FREEZE	
AUTO SETUP	INDEX-WINDOW	
ASPECT	PICTURE MODE	
<b>TEST PATTERN</b>		page 38
<b>DETAILED SETUP</b>		page 38
<b>OSD DESIGN</b>		
<u>TYPE1</u>	TYPE2	
TYPE3		
<b>SXGA MODE</b>		
<u>SXGA+</u>	SXGA	
<b>BLACKBOARD</b>		
<u>ON</u>	OFF	
<b>BACK COLOR</b>		
<u>BLUE</u>	BLACK	
<b>VOLUME</b> (Default: 20)		
<b>AUDIO BALANCE</b> (Default: 0)		
<b>INITIALIZE ALL</b>		

 **SECURITY**

<b>INPUT PASSWORD</b>		page 39
<u>OFF</u>	ON	
<b>PASSWORD CHANGE</b>		page 39
<b>TEXT DISPLAY</b>		page 39
<u>OFF</u>	ON	
<b>TEXT CHANGE</b>		page 39

 **WIRELESS**

(PT-LB80NTE/PT-LB75NTE only)

<b>NETWORK</b>		
<b>NAME CHANGE</b>		
<b>INPUT PASSWORD</b>		
<b>PASSWORD CHANGE</b>		
<b>NETWORK STANDBY</b>		
<b>WEB CONTROL</b>		
<b>LIVE MODE CUT IN</b>		
<b>STATUS</b>		
<b>INITIALIZE</b>		
		page 40*1

\*1. See CD-ROM contents for more detailed information.



# PICTURE menu

## Remote control

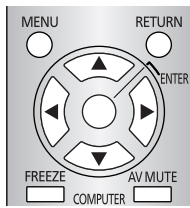

## Control panel

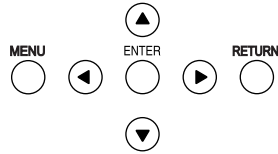

- See “Navigating through the MENU” on page 29.
- See “Main menu and Sub-menu” on page 30.

## PICTURE MODE

Depending on the projection environment, you can use these preset parameter settings to optimise image projection. Press ◀ ▶ to cycle through the options.

<b>NATURAL</b>	Reproduces the original colour of the image
<b>STANDARD</b>	Setting for a general image
<b>DYNAMIC</b>	Bright and sharp setting
<b>BLACKBOARD</b>	Setting for when projecting on a blackboard See “BLACKBOARD” on page 38.

### NOTE:

- The default setting varies according to the selected signal.
- It may take for a while until the selected mode is stabilised.

## CONTRAST

You can adjust the contrast of the projected image. Adjust the **BRIGHTNESS** in advance if necessary.

Lower  Higher

## BRIGHTNESS

You can adjust the brightness of the projected image.

Darker  Brighter

## COLOR

You can adjust the colour saturation of the projected image. (Available with signals of **VIDEO/S-VIDEO/YPbPr** only)

Lighter



Darker

## TINT

You can adjust the skin tone in the projected image. (Available with signals of **VIDEO/S-VIDEO/YPbPr** only)

More reddish



More greenish

## SHARPNESS

You can adjust the sharpness of the projected image and the adjustable range depends on the input signal.

Less sharp



More sharp

## COLOR TEMPERATURE

You can adjust the white balance of the projected image. Press ◀ ▶ to cycle through the options.

- **STANDARD** Balanced white
- **HIGH** More bluish
- **LOW** More reddish

## DAYLIGHT VIEW

You can keep the projected image bright and vivid even in well-lit rooms where the ambient light sources cannot be controlled, such as when a door opens or when window coverings fail to block out sunlight.

- **AUTO:** Automatic adjustment
- **ON:** Active
- **OFF:** Deactive

### NOTE:

- Do not cover the Ambient Luminance Sensor (**ALS**) of the projector. See “Ambient Luminance Sensor (ALS)” on page 14.
- **AUTO** is not available when **INSTALLATION** setting in **OPTION** menu is set to **REAR/DESK** or **REAR/CEILING**.

## DETAILED SETUP

You can perform more detailed image adjustment manually.

### For S-VIDEO/VIDEO signals

#### TV-SYSTEM

When the video signal is changed, the setting switches automatically. You can switch the setting manually to match the video data. Press ◀ ▶ to cycle through the options.

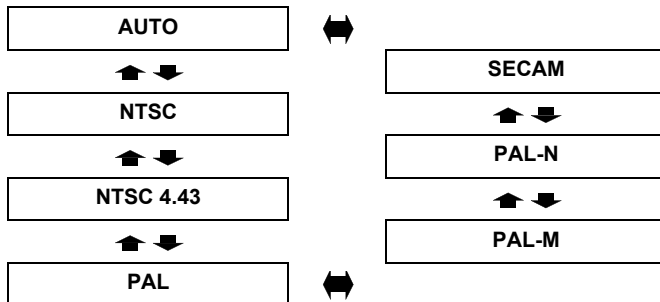

#### NOTE:

- **AUTO** setting will select from NTSC/NTSC 4.43/PAL/PAL60/PAL-M/PAL-N/SECAM.

#### STILL MODE

You can reduce the vertical flicker when projecting a still image.

- **OFF:** Deactive
- **ON:** Active

#### NOTE:

- Set to **OFF** when projecting a moving image.

#### NOISE REDUCTION

You can switch the automatic noise reduction system on/off. Press ◀ ▶ to select the required setting.

- **OFF:** No noise reduction
- **ON:** Automatic noise reduction

#### NOTE:

- Applying noise reduction may affect the image quality.

### For RGB signals

You can adjust the white balance more properly in 3 colours temperature by pressing ◀ ▶.

- **WHITE BALANCE RED**
- **WHITE BALANCE GREEN**
- **WHITE BALANCE BLUE**

# POSITION menu

## Remote control

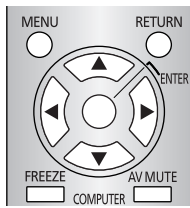

## Control panel

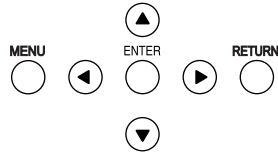

- See "Navigating through the MENU" on page 29.
- See "Main menu and Sub-menu" on page 30.

## REALTIME KEYSTONE

If the projector is aligned non-perpendicularly to the screen, or if the projection screen has an angled surface, the keystone will be corrected automatically. Press ◀ ▶ to select the required setting.

- **ON:** Active
- **OFF:** Deactive

## KEYSTONE

If you need to correct the angle of the projection even when the **REALTIME KEYSTONE** is activated, you can correct the keystone manually.

Image	Operation

### NOTE:

- You can correct the distortion  $\pm 30$  degrees from the plane. For a better quality image, installing the projector with a minimum of distortion is recommended.
- The distortion of the Main menu screen is not correctable.
- The result of the keystone correction will affect the aspect ratio and the size of the image.

## POSITION

You can move the projected image for fine adjustment. Press ◀ ▶ to move horizontally and ▲ ▼ vertically. (Available with signals of **VIDEO/S-VIDEO/RGB/YPbPr** only)

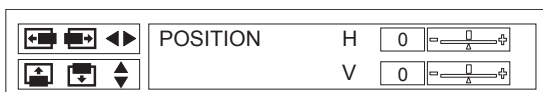

## DOT CLOCK

If you have interference patterns of the projected image, which is sometimes referred to as moire or noise, you can minimize it by pressing ◀ ▶ to adjust the clock frequency. (Available with signals of **RGB** only)

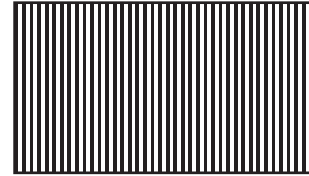

### NOTE:

- If the projecting signal's dot clock frequency is higher than 108 MHz, the adjustment may not make a difference.
- **DOT CLOCK** needs to be adjusted before adjust the **CLOCK PHASE**.

## CLOCK PHASE

If you require further adjustment for the same reason as the **DOT CLOCK** adjustment, you can fine adjust the timing of the clock. Press ◀ ▶ to adjust. (Available with signals of **RGB/YPbPr** only)

### NOTE:

- If the projecting signal's dot clock frequency is higher than 108 MHz, the adjustment may not make a difference. See "List of compatible signals" on page 46.

## ASPECT

You can switch the aspect ratio manually when needed. Press ◀ ▶ to cycle through the options.

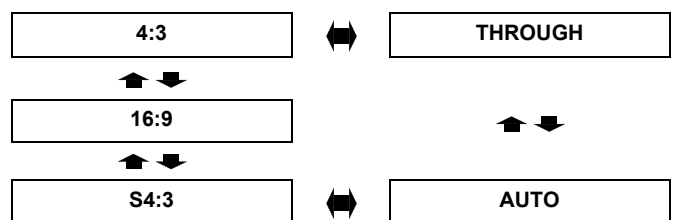

- Selectable options vary according to a input signal.

### ● 4:3

The input signal will be projected in 4:3 ratio.

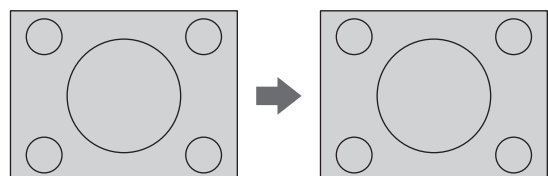

● **16:9**

The squeezed signal will be projected in 16:9 ratio.

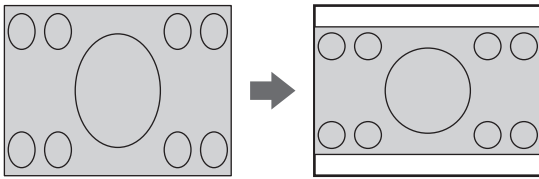

● **S4:3**

The input signal will be sized down 75 % and projected. **S4:3** mode is effective when projecting 4:3 image on to a 16:9 screen.

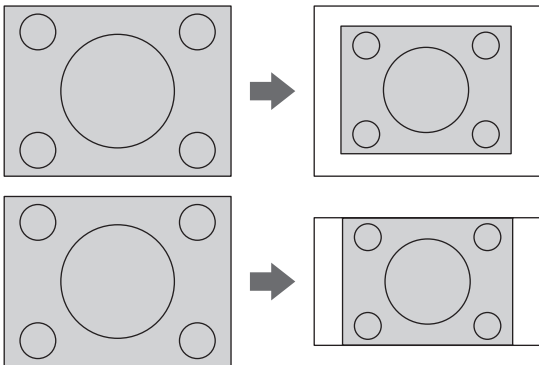

● **THROUGH**

The image will be projected without any size adjustment.

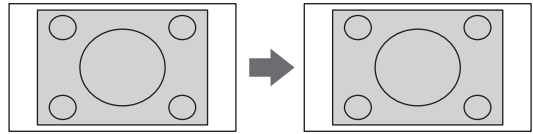

● **AUTO**

The signal which contains an identifying signal will be detected and automatically project the image in proper ratio.

**NOTE:**

- **WIDE MODE** in **OPTION** menu should be **ON** when projecting WIDE signals.
- If you project an image with an unmatched aspect ratio, the image may distort or some portions may be cropped. Select an aspect ratio which preserves the intention of the image creator.
- The order of **ASPECT** types is defined not only by the input method but also by the input signals. See "List of compatible signals" on page 46.
- If you project a copyrighted image enlarged or distorted by using **ASPECT** function in commercial use in a public place, such as a restaurant or hotel, you might infringe on the copyright of the creator which is protected by copyright law.

**FRAME LOCK**

If the projected image is degraded, you can activate **FRAME LOCK** for synchronisation. Press ◀ ▶ to select the required option. (Available with signals of **RGB** only)

- **OFF** Deactive
- **ON** Active

# OPTION menu

**Remote control**

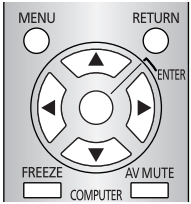

- See "Navigating through the MENU" on page 29.
- See "Main menu and Sub-menu" on page 30.

**Control panel**

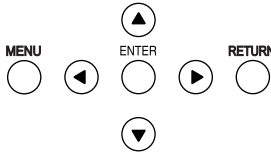

## INPUT GUIDE

When you change the input method, the guidance appears in the upper right corner of the screen. The following display methods are available. Press ◀ ▶ to cycle through the options.

Options	Function
<b>DETAILED</b>	Display the input method by graphic. The <b>INPUT GUIDE</b> will go out after 10 seconds without any operation. If you select any of the <b>COMPUTER</b> terminals which has no signal, the computer connection guidance will be displayed. See "Computer connection guidance" on page 48.
<b>SIMPLE</b>	Display the input method by text. The <b>INPUT GUIDE</b> will go out after 5 seconds without any operation.
<b>OFF</b>	Turn off the guidance.

## STARTUP LOGO

You can switch the logo on/off that is displayed when starting up the projector. Press ◀ ▶ to select the required option. **STARTUP LOGO** will be displayed for 30 seconds.

- **ON**                      Active
- **USER**                  Display the original text
- **OFF**                     Deactive

### ● Editing the original text

If you select **USER**, you can display a 2 lines of original text which contains up to 40 characters in each.

TEXT CHANGE

A	B	C	D	E	F	G	H	I	J	K	L	M	ALL DELETE		
N	O	P	Q	R	S	T	U	V	W	X	Y	Z			
a	b	c	d	e	f	g	h	i	j	k	l	m			
n	o	p	q	r	s	t	u	v	w	x	y	z			
0	1	2	3	4	5	6	7	8	9	SPACE					
!	"	#	\$	%	&	'	*	+	-	/	=	?	@	\	^
_	`		~	(	)	<	>	[	]	{	}	,	.	:	;

OK

CANCEL

1. Select **USER** and press the **ENTER** button.
2. Select the required line to enter or edit the original text, and press the **ENTER** button.
3. Use ▲ ▼ ◀ ▶ to specify the location of the required character and press the **ENTER** button.
  - The selected character will be displayed in the box.
4. Repeat the step 3 until you finish the text to display in a line.
  - To delete all the entered characters, move the cursor to **ALL DELETE** and press the **ENTER** button.
  - To insert a character in the entered text line, move the cursor to the text box to select the required place, and press ▼ and return to the character field.
  - To delete a character, press the **DEFAULT** button or move the cursor to the required character then press the **DEFAULT** button.
5. Select **OK** and press the **ENTER** button to set the entered text in a box.
  - Press ▼ and edit the **TEXT2** if you need to, and repeat the step 3 - 5.
  - Select **CANCEL** or press the **MENU/RETURN** button to return to the previous menu without setting.

## COMPUTER2 SELECT

You can switch the function of the **COMPUTER2 IN/1 OUT** terminal.

- **INPUT**
- COMPUTER2 IN**
- **OUTPUT**
- COMPUTER1 OUT**

## RGB/YPBPR

The projector will detect the signal from the **COMPUTER1 IN** or **COMPUTER2 IN/1 OUT** terminal if the signal is RGB or YPBPR. You can turn off the automatic system and switch the settings manually.

- **AUTO**                      Automatic adjustment
- **RGB**                        For RGB signals
- **YPBPR**                    For YPBPR signals

### NOTE:

- Available with VGA60, 480i, 576i, 480p, 576p, 1 125 (1 080)/60i, 1 125 (1 080)/50i, 720/60p, 720/50p only.
- When the input signal is not selected correctly with **AUTO** setting, select **RGB** or **YPBPR** manually.

## WIDE MODE

When projecting WIDE signals, switch to **ON** to display the image in well adjusted size.

- **OFF**                        For 4:3 signals
- **ON**                         For WIDE signals (16:9, 16:10 and 15:9)

## LAMP POWER

You can adjust the power of the lamp to save electricity, prolong the lamp life and reduce the noise.

- **STANDARD** When higher luminance is required
- **ECO-MODE** When lower luminance is sufficient

### NOTE:

- When no input signal is detected, the function is disabled.
- The **ECO-MODE** setting is recommended when higher luminance is not required such as in a small room.

## LAMP RUNTIME

You can check how long the lamp has been used.

### NOTE:

- **LAMP RUNTIME** is a relevant matter for lamp replacement timing. See “Replacing the Lamp unit” on page 43.
- When the lamp unit is replaced with the new unit, the setting need to be reset to “0”.

## POWER OFF TIMER

You can set the off timer to switch off the power of the projector after a certain period of time automatically when no signal is detected. Press ◀▶ to select the required period from 15 to 60 minutes at intervals of 5 minutes.

## DIRECT POWER ON

You can switch the projector start up status for when the electric power is supplied. Press ◀▶ to select the required option.

- **OFF** Starts in the same mode as last use.
- **ON** Skips the standby mode and starts the projection.

### NOTE:

- If the projector is started from the projecting mode, the **POWER** button pressing procedure is skippable.

## CONTROL PANEL

You can turn off the function of the control panel buttons on the projector body. Press ◀▶ to select the required option.

- **VALID** Validate the control panel buttons
- **INVALID** Invalidate the control panel buttons  
The confirmation screen will be displayed.

## AUTO SETUP

You can turn off the automatic **AUTO SETUP** adjustment system.

- **AUTO** When the projector detect a **COMPUTER** signal, automatically set the setting of **POSITION**, **DOT CLOCK** and **CLOCK PHASE** in **POSITION** menu.
- **BUTTON** Only when the **AUTO SETUP** button is pressed, automatically set the **POSITION**, **DOT CLOCK** and **CLOCK PHASE** in **POSITION** menu for **COMPUTER** signals. See “Remote control” on page 16.

### NOTE:

- **AUTO** setting is recommended.

## SIGNAL SEARCH

You can turn off the auto signal detecting system.

- **ON** Detect the input signal from the terminals and project the image.
- **OFF** Deactive

### NOTE:

- **SIGNAL SEARCH** is not available when any input signal is projected.

## INSTALLATION

When installing the projector, select the projection method according to the projector position. Press ◀▶ to cycle through the options. See “Projection method” on page 18.

<b>FRONT/DESK</b>	Setting on a desk/floor and projecting from front
<b>FRONT/CEILING</b>	Mounting in the ceiling and projecting from front
<b>REAR/DESK</b>	Setting on a desk/floor and projecting from rear
<b>REAR/CEILING</b>	Mounting in the ceiling and projecting from rear

## ALTITUDE

If you use the projector at high elevation, the **ALTITUDE** setting need to be **HIGH** to set the fan speed high. Press ◀▶ to select the required option.

- **LOW** The fan speed is low.
- **HIGH** The fan speed is high.

### NOTE:

- At 1 400 -2 700 m (4 593 - 8 858 ft) sea level, the setting must be **HIGH**.
- The loudness of fan noise depends on the **ALTITUDE** setting.

## OPTION menu

### FUNCTION BUTTON

You can select a useful function from the list and assign to the **FUNCTION** button for shortcut.

1. Press the **ENTER** button.
2. Press **▲ ▼** to select the required function.
3. Press the **ENTER** button.
  - The dot on the left of the option is indicating the assigned function.

Option items	Refer
<b>AV MUTE</b>	page 26
<b>FREEZE</b>	page 26
<b>AUTO SETUP</b>	page 25
<b>INDEX-WINDOW</b>	page 27
<b>ASPECT</b> <ul style="list-style-type: none"><li>• Calls up the <b>ASPECT</b> in <b>POSITION</b> menu. Press <b>◀ ▶</b> to select the required option.</li></ul>	page 34
<b>PICTURE MODE</b> <ul style="list-style-type: none"><li>• Calls up the <b>PICTURE MODE</b> in <b>PICTURE</b> menu. Press <b>◀ ▶</b> to select the required option.</li></ul>	page 32

#### NOTE:

- The called up menu item will be disappeared after 5 seconds without any operation.

### TEST PATTERN

You can use the 7 different test patterns to adjust the focus of the image. See "Positioning the image" on page 24.

1. Press the **ENTER** button to display the test pattern 1.
2. Press **◀ ▶** to select the required test pattern.
3. Press the **MENU** or **RETURN** button to return to the previous menu, or press repeatedly to escape the menu mode.

### DETAILED SETUP

You can perform more detailed setting in various items.

#### OSD DESIGN

You can change the background colour of the menu. Press **◀ ▶** to select the required option.

<b>TYPE1</b>	Semi transparent black
<b>TYPE2</b>	Solid blue
<b>TYPE3</b>	Semi transparent dark blue

#### SXGA MODE

Switch to the **SXGA** setting when inputting SXGA signal. Press **◀ ▶** to select the required option.

#### BLACKBOARD

You can exclude the **BLACKBOARD** in menu items of **PICTURE MODE** in **PICTURE** menu. Press **◀ ▶** to select the required option.

- **ON** Include the **BLACKBOARD** in menu items.
- **OFF** Exclude the **BLACKBOARD** in menu items.

#### BACK COLOR

You can choose a **BLUE** or **BLACK** screen for when the projector is idle. Press **◀ ▶** to select the required option.

#### VOLUME

You can adjust the volume of the built-in monaural speaker and **VARIABLE AUDIO OUT** terminal.

- **◀** Decrease
- **▶** Increase

#### AUDIO BALANCE

You can adjust to hear the sound played equally through both right and left external stereo speakers, or shift the balance so more sound plays through the left or right side.

- **◀** More sound plays through the left side
- **▶** More sound plays through the right side

#### INITIALIZE ALL

You can reset all of the customised settings to the factory defaults except **WIRELESS** and **LAMP RUNTIME** menu settings.

1. Press the **ENTER** button
2. Turn off the projector by pressing the **POWER** button.
3. Reset the projector by unplugging and plugging the mains lead from the mains socket..
4. The minimum required setting screen will be displayed.
  - See "Minimum required setting screen" on page 13.

#### NOTE:

- The security system is deactivated by default and when initialised.
- When the projector is initialised, it will be reset to the factory default password operation.

# SECURITY menu

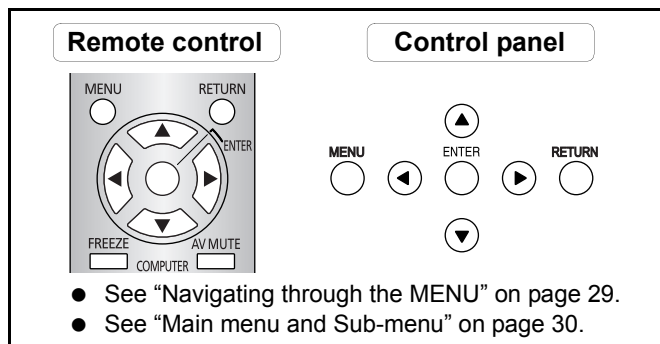

## Entering the SECURITY menu

Every time when you apply to the **SECURITY** menu, you will be asked to perform the password operation.

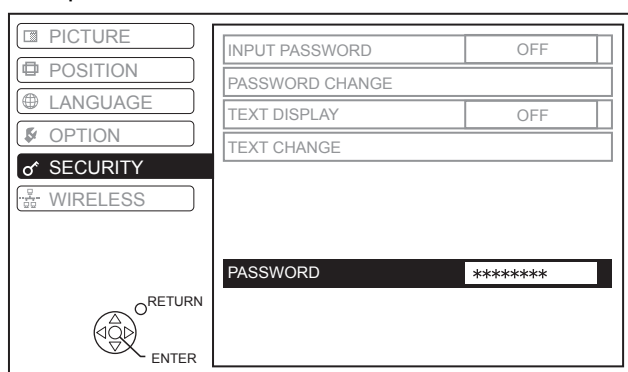

When you apply to the **SECURITY** menu before you change the password to your original, perform to input the following factory default password operation.

- Press **▲▶▼◀▲▶▼◀** and the **ENTER** button.

## After you change the password

When you apply to the **SECURITY** menu after you change the password to your original in the **PASSWORD CHANGE** menu, input the original password operation.

### NOTE:

- The factory default password is valid until you change the password in **PASSWORD CHANGE** menu.
- The entered password operations will appear as asterisks in the box.

## INPUT PASSWORD

You can activate the security system and the password operation will be asked to perform when projecting mode started. Unless you perform the correct password operation, all of the button controls will be disabled except the **POWER** button.

- **OFF** Deactive
- **ON** Active

### NOTE:

- When you activated the security system, make sure to change the password to your original for safety.
- The security system is deactivated by default and when initialised.

## PASSWORD CHANGE

You can change the password operation to your original.

1. Press a series of button operation up to 8 as a password by using **▲ ▼ ◀ ▶** buttons.
2. Press the **ENTER** button.
3. Press the exact same series of button operation you entered in the **NEW** password box for confirmation.
  - If a series of button operation is incorrect, you will be asked to perform again.
4. Press the **ENTER** button.

### NOTE:

- The entered password operations will appear as asterisks in the box.
- Change your password regularly.
- Do not use too simple password to guess.

## TEXT DISPLAY

You can set your original text, such as company name or URL information, to display regularly at the bottom of the projected image while projecting.

- **OFF** Deactive
- **ON** Active

## TEXT CHANGE

You can enter your original text up to 22 characters for **TEXT DISPLAY**.

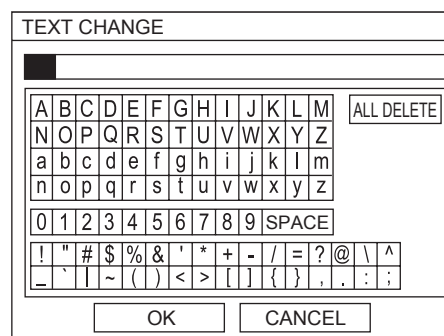

1. Use **▲ ▼ ◀ ▶** to specify the location of the required character and press the **ENTER** button.
  - The selected character will be displayed in the **TEXT CHANGE** box.
2. Repeat step 1 until finish your original text.
  - To delete all the entered characters, move the cursor to **ALL DELETE** and press the **ENTER** button.
  - To insert a character in the entered text line, move the cursor to the text box to select the required place, and press **▼** and return to the character field.
  - To delete a character, press the **DEFAULT** button or move the cursor to the required character then press the **DEFAULT** button.
3. Select **OK** and press the **ENTER** button to set the entered text.
  - Select **CANCEL** or press the **MENU/RETURN** button to return to the previous menu without setting.



# WIRELESS menu

## Remote control

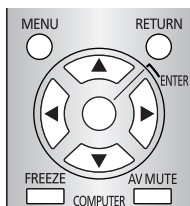

## Control panel

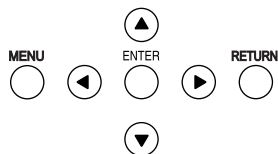

- See "Navigating through the MENU" on page 29.
- See "Main menu and Sub-menu" on page 30.

### NOTE:

- The **WIRELESS** menu is available only with PT-LB80NTE/PT-LB75NTE.
- See the wireless connecting information in the contents of the CD-ROM which is provided with the projector.
- When **INPUT PASSWORD** in **SECURITY** menu is activated, perform the correct password operation to initialise the projector via network.

## Items in WIRELESS menu

In **WIRELESS** menu, the following items are available.

- **NETWORK**
- **NAME CHANGE**
- **INPUT PASSWORD**
- **PASSWORD CHANGE**
- **NETWORK STANDBY**
- **WEB CONTROL**
- **LIVE MODE CUT IN**
- **STATUS**
- **INITIALIZE**

# LAMP and TEMP Indicators

## Managing the indicated problems

If a problem should occur with the projector, the **LAMP** and/or **TEMP** indicators will inform you. Manage the indicated problems as follow.

1. Confirm the status of all indicators and projector, and switch off the projector in proper way.
  - See “Switching the projector on/off” on page 20.
2. Find out the cause of the problem by status of the **LAMP** and/or **TEMP** indicators.
3. Follow the instruction for each indication below and solve the problem.
4. Turn on the projector in the correct way and confirm the indicator is not indicating a problem any longer.

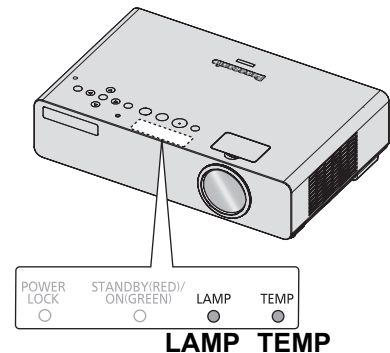

### NOTE:

- If no problem is found or the problem remains, do not turn on the projector. Instead contact an Authorised Service Centre.

### LAMP indicator

Indicator	Illuminating red	Flashing red		
Problem	<b>LAMP RUNTIME</b> has reached 2 800 hours.	<b>LAMP</b> circuit failure, abnormal function or the lamp unit is damaged.		
Cause	Lamp unit will run out soon and needs to be replaced.	The projector is switched on again too soon.	<b>LAMP</b> circuit failure, abnormal function.	Lamp unit is damaged.
Remedy	See “Replacing the Lamp unit” on page 43.	Let the lamp unit cool down and turn on the projector after 90 seconds.	Switch off the projector and contact an Authorised Service Centre.	See “Replacing the Lamp unit” on page 43.

### TEMP indicator

Indicator	Illuminating red while projecting and the alert will be displayed. Flashing red and power is turned off			
Problem	The temperature inside and/or outside the projector is abnormally high. <ul style="list-style-type: none"> <li>● The projection may becomes darker than usual.</li> <li>● The internal fan operational noise may be louder than usual.</li> </ul>			
Cause	The ventilation openings are covered.	The room temperature is too high.	The filter is excessively dirty and the ventilation is poor.	The projector is located at 1 400 - 2 700 m (4 593 - 8 858 ft).
Remedy	Remove the object(s) from the ventilation openings or clear around the projector.	Reinstall the projector in temperature controlled place. See page 50.	Clean the filter in the proper method. See page 42.	Turn on the projector* <sup>1</sup> and set the <b>ALTITUDE</b> to <b>HIGH</b> . See page 37.

\*1. The projector will perform 2 minutes with **LOW** setting at high elevation.

# Care and Replacement

## Cleaning the projector

### Before cleaning the projector

- Switch off the projector and disconnect the mains plug from the mains socket.
- Unplug all the cables from the projector.

### Cleaning the outer surface of the projector

Wipe off dirt and dust gently with a soft cloth.

- If it is difficult to remove the dirt, soak a cloth with water, wring the cloth well and then wipe the projector. Dry off the projector with dry cloth.
- Do not use petroleum benzine, thinner, any alcoholic solvent, kitchen detergents or chemical clothes. Failure to observe these may result in altered or damaged surface of the projector.

### Cleaning the front glass surface

Wipe off dirt and dust gently with a lint-free cloth.

- Make sure no dirt or dust remains on the surface of the lens cover glass. It will be enlarged and projected onto a screen.

#### NOTE:

- Clean the front glass with special care. Giving a shock may cause serious damage.

### Cleaning the air filter

If the air filter is excessively dirty, the internal temperature of the projector increases and may cause malfunction. Clean the air filter regularly every 100 hours of usage.

1. Turn the projector upside down and place it gently on a soft cloth.
2. Press the tab and slightly slide up the air filter to remove.
3. Vacuum dirt and dust from the air filter.
  - Do not wash the air filter.
4. Place and slightly slide in the air filter in the air intake port to attach.
  - Make sure the air filter clicks into the place.

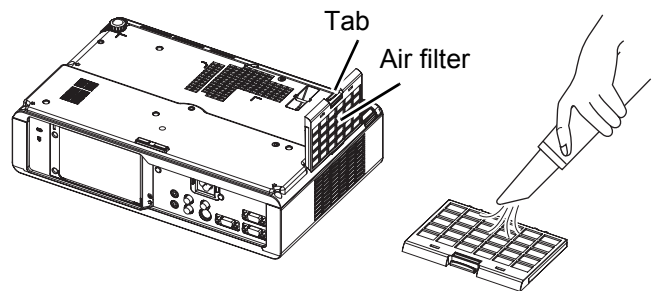

#### NOTE:

- Do not use the projector without attaching the air filter.

### Replacing the air filter



The air filter should be replaced when cleaning is ineffective and when replacing lamp unit. A replacement air filter is provided with a replacement lamp unit (ET-LAB80). Contact an Authorised Service Centre for the optional air filter (TXFMZ01VKG7).

## Replacing the Lamp unit

The lamp unit, ET-LAB80 is consumable and you must replace it regularly. It is recommended that a qualified technician carry the lamp unit replacement and consult with an Authorised Service Centre.

### When to replace the Lamp unit

When the lamp is consumed, the brightness may decrease over time. 3 000 hours of use is the replacing timing as rough guided, and that might be shortened by the usage conditions, characteristics of the lamp unit or environmental conditions. You can find the duration of usage time by checking **LAMP RUNTIME** in **OPTION** menu.

<b>Indication</b>	On screen 	<b>LAMP</b> indicator 
<b>Over 2 800 hours</b>	Displays " <b>REPLACE LAMP</b> " on the upper left of the screen for 30 seconds.	Illuminates red.
<b>Over 3 000 hours</b>	Displays " <b>REPLACE LAMP</b> " on the upper left of the screen, and it will stay until you respond. Press any button to clear the screen.	

#### NOTE:

- The guide times, 2 800 and 3 000 hours, are rough estimates based on certain conditions and is not a guaranteed time.
- For more information about the lamp unit and its guaranteed time, see the instructions which is provided with the lamp unit.
- Do not use a lamp unit over 3 000 hours. Failure to observe this may result in explosion of the lamp.

### Before replacing the lamp unit

- Contact an Authorised Service Centre to purchase a replacement lamp unit (ET-LAB80).
- Switch off the projector and disconnect the mains plug from the mains socket.
- Wait for more than 1 hour and make sure the lamp unit and the surroundings are cooled enough.
- Prepare a Phillips-head screwdriver.
- When the projector is mounted in the ceiling, do not work directly under the projector or put your face closer to the projector.

#### NOTE:

- Prior to replacing the lamp unit, allow it to cool down to prevent the risk of burns, damage and other hazards.
- Do not attempt replacement with an unauthorised lamp unit.

# Care and Replacement

## Replacement procedure

### Removing and replacing the lamp unit

1. Use a Phillips-head screwdriver to loosen the 2 lamp unit cover fixing screws on the back of the projector until the screws turn freely, and remove the lamp unit cover.

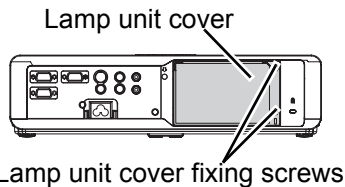

2. Use a Phillips-head screwdriver to loosen the 3 lamp unit fixing screws.

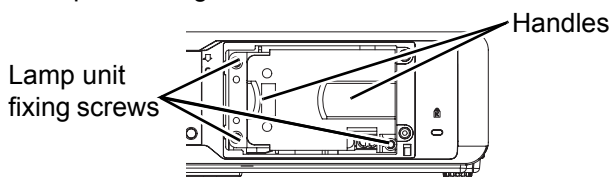

3. Pull the used lamp unit gently from the projector.
  - Grip the handle and keep the lamp unit paralleled when you remove the lamp. Some parts of the lamp unit are sharpened and may cause injury.

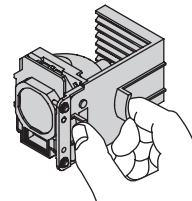

4. Replace the new lamp unit in correct direction.
5. Press in the lamp unit until it clicks and make sure the unit is installed securely.
6. Tighten the 3 lamp unit fixing screws securely with a Phillips-head screwdriver.

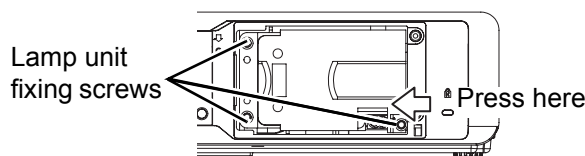

7. Attach the lamp unit cover and tighten the 2 lamp unit cover fixing screws securely with a Phillips-head screwdriver.

#### NOTE:

- Be sure to install the lamp unit and attach the lamp unit cover securely. If they are not installed securely, it may cause the protection circuit to operate so that the power cannot be turned on.
- Do not switch the power on while the lamp unit cover removed.
- Handle the lamp unit with special care as that is a glass product. Dropping or giving a shock may cause burst or damage.

### Resetting the LAMP RUNTIME

1. Connect the mains lead to a mains socket, and switch on the projector.
2. Press the **MENU** button to display the menu.
3. Press **▲ ▼** to select **OPTION** and press **ENTER**.
4. Press **▲ ▼** to select **LAMP RUNTIME**.
5. Press and hold the **ENTER** button for approximately 3 seconds.
6. The confirmation screen will be displayed and select **OK**.
7. Reset the projector by unplugging and plug again the mains lead.
8. Display the **LAMP RUNTIME** menu again and confirm the duration of time is reset to "0 H".

LAMP POWER	STANDARD
LAMP RUNTIME	1820H

# Troubleshooting

Should any problem persist, contact your dealer.

Problem	Cause	Reference page
<b>Power does not turn on.</b>	● The mains lead may not be connected securely.	20
	● No electric supply at the mains socket.	21
	● <b>TEMP</b> indicator is lit or flashes.	41
	● <b>LAMP</b> indicator is lit or flashes.	41
	● The lamp unit cover has not been securely installed.	44
	● The circuit breakers have tripped.	-
<b>No picture appears.</b>	● The signal input source may not be connected to a terminal properly.	19
	● The input selection setting may not be correct.	26
	● The <b>BRIGHTNESS</b> adjustment setting may be at the minimum setting.	32
	● The signal input source may not be operating properly.	-
	● The <b>AV MUTE</b> function may be in use.	26
<b>The picture is fuzzy.</b>	● The lens focus may not have been set correctly.	24
	● The projector may not be at the correct distance from the screen.	17
	● The lens may be dirty.	42
	● The projector may be tilted too much.	17/18
<b>The colour is pale or greyish.</b>	● <b>COLOR</b> or <b>TINT</b> adjustment may be incorrect.	32
	● The input source which is connected to the projector may not be adjusted correctly.	30
<b>No sound can be heard from the internal speaker.</b>	● The audio signal source may not be connected properly.	19
	● A cable may be connected to the <b>VARIABLE AUDIO OUT</b> terminal.	15
	● The volume adjustment may be at the lowest possible setting.	27
<b>The control buttons of the projector do not operate.</b>	● <b>CONTROL PANEL</b> in <b>OPTION</b> menu is invalidated. If you have a loss of the remote control while the <b>CONTROL PANEL</b> is invalidated, press and hold the <b>MENU</b> button for 2 seconds with pressing the <b>ENTER</b> button.	37
<b>The Remote control does not operate.</b>	● The batteries may be weak.	-
	● The batteries may not have been inserted correctly.	16
	● The remote control signal receptor on the projector may be obstructed.	25
	● The remote control unit may be out of the operation range.	25
	● The remote control is under the strong light such as fluorescent.	25
<b>The picture does not display correctly.</b>	● The signal format ( <b>TV-SYSTEM</b> ) may not have been set correctly.	33
	● There may be a problem with the VCR or other signal source.	-
	● A signal which is not compatible with the projector is being input.	46
<b>Picture from a computer does not appear.</b>	● The cable may be longer than the optional cable.	-
	● The external video output from a laptop computer may not be correct. (You may be able to change the external output settings by pressing the [Fn] + [F3] or [Fn] + [F10] keys simultaneously. The actual method varies depending on the type of computer; refer to the documentation provided with your computer for further details.)	48
	● <b>COMPUTER2 SELECT</b> setting in <b>OPTION</b> menu is not correct.	36

# Technical Information

## List of compatible signals

Mode	Display resolution (dots) <sup>*1</sup>	Scanning frequency		Dot clock frequency (MHz)	Picture quality <sup>*2</sup>	Terminals
		H (kHz)	V (Hz)			
NTSC/NTSC 4.43/ PAL-M/PAL60	720 x 480i	15.7	59.9	-	A	VIDEO/S-VIDEO
PAL/PAL-N/SECAM	720 x 576i	15.6	50.0	-	A	
525i (480i)	720 x 480i	15.7	59.9	13.5	A	COMPUTER/YPBPR
625i (576i)	720 x 576i	15.6	50.0	13.5	A	
525p (480p)	720 x 483	31.5	59.9	27.0	A	
625p (576p)	720 x 576	31.3	50.0	27.0	A	
1 125 (1 080)/60i	1 920 x 1 080i	33.8	60.0	74.3	A	
1 125 (1 080)/50i	1 920 x 1 080i	28.1	50.0	74.3	A	
750 (720)/60p	1 280 x 720	45.0	60.0	74.3	A	COMPUTER/YPBPR <sup>*3</sup>
750 (720)/50p	1 280 x 720	37.5	50.0	74.3	A	
VESA	640 x 400	31.5	70.1	25.2	A	COMPUTER
	640 x 400	37.9	85.1	31.5	A	
VGA	640 x 480	31.5	59.9	25.2	A	
	640 x 480	35.0	66.7	30.2	A	
	640 x 480	37.9	72.8	31.5	A	
	640 x 480	37.5	75.0	31.5	A	
	640 x 480	43.3	85.0	36.0	A	
SVGA	800 x 600	35.2	56.3	36.0	A	
	800 x 600	37.9	60.3	40.0	A	
	800 x 600	48.1	72.2	50.0	A	
	800 x 600	46.9	75.0	49.5	A	
	800 x 600	53.7	85.1	56.3	A	
MAC	832 x 624	49.7	74.6	57.3	A	
XGA	1 024 x 768	39.6	50.1	51.9	AA	
	1 024 x 768	48.4	60.0	65.0	AA	
	1 024 x 768	56.5	70.1	75.0	AA	
	1 024 x 768	60.0	75.0	78.8	AA	
	1 024 x 768	68.7	85.0	94.5	AA	
MXGA	1 152 x 864	64.0	71.2	94.2	A	
	1 152 x 864	67.5	74.9	108.0	A	
	1 152 x 864	77.1	85.0	119.7	B	
MAC	1 152 x 870	68.7	75.1	100.0	A	
MSXGA	1 280 x 960	60.0	60.0	108.0	A	
SXGA	1 280 x 1 024	64.0	60.0	108.0	A	
	1 280 x 1 024	80.0	75.0	135.0	B	
	1 280 x 1 024	91.1	85.0	157.5	B	
SXGA60+	1 400 x 1 050	64.0	60.0	108.0	A	
	1 400 x 1 050	65.1	59.9	122.4	B	
UXGA	1 600 x 1 200	75.0	60.0	162.0	B	
WIDE750 (720)	1 280 x 720	44.8	59.9	74.5	A	
	1 280 x 720	37.1	49.8	60.5	A	
WXGA768	1 280 x 768	39.6	49.9	65.3	A	
	1 280 x 768	47.8	59.9	79.5	A	
WXGA800	1 280 x 800	41.3	50.0	68.0	A	
	1 280 x 800	49.1	60.2	69.1	A	
	1 280 x 800	49.7	59.8	83.5	A	
WXGA+	1 440 x 900	55.9	59.9	106.5	A	
WSXGA+	1 680 x 1 050	65.3	60.0	146.3	B	
WUXGA	1 920 x 1 200	74.6	59.9	193.3	B	

\*1. The "i" appearing after the resolution indicates an interlaced signal.

\*2. The following symbols are used to indicate picture quality.

AA Maximum picture quality can be obtained.

A Signals are converted by the image processing circuit before picture is projected.

B Some loss of data occurs to make projection easier.

\*3. Displays 750 (720)/60p or 750 (720)/50p signals through COMPUTER terminals as WIDE750 (720). Press the **AUTO SETUP** button or correct the **POSITION** menu settings to align the image with the screen size.

## Serial terminal

The serial connector which is on the connector panel of the projector conforms to the RS-232C interface specification, so that the projector can be controlled by a personal computer which is connected to this connector.

### Connection

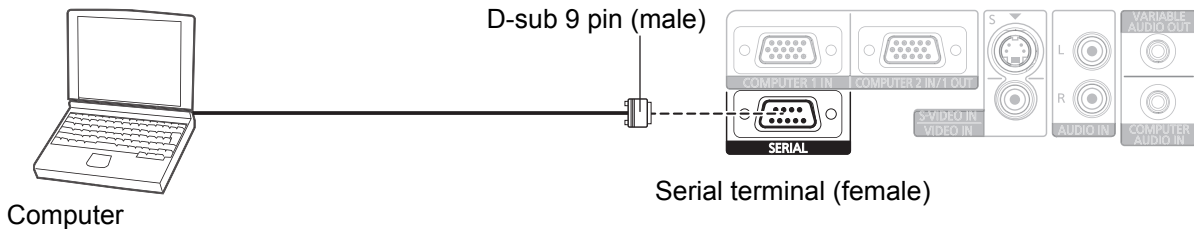

### Pin assignments and signal names

	Pin No.	Signal name	Contents
	①		NC
	②	TXD	Transmitted data
	③	RXD	Received data
	④		NC
	⑤	GND	Earth
	⑥		NC
	⑦	RTS	Connected internally
	⑧	CTS	
	⑨		NC

### Communication settings

<b>Signal level</b>	RS-232C	<b>Character length</b>	8 bits
<b>Sync. method</b>	Asynchronous	<b>Stop bit</b>	1 bit
<b>Baud rate</b>	9 600 bps	<b>X parameter</b>	None
<b>Parity</b>	None	<b>S parameter</b>	None

### Basic format

STX	Command	:	Parameter	ETX
Start byte (02h)	3 bytes	1 byte	1 byte - 4 bytes	End (03h)

The data streaming from the computer will start with STX, and proceed to Command, Parameter and end with ETX. You can add the required parameter.

- The projector can not receive any command for 10 seconds after the lamp is switched on. Wait 10 seconds before sending the command.
- If sending multiple commands, check that a response has been received from the projector for one command before sending the next command.
- When a command which does not require parameters to be sent, the colon (:) is not required.
- If an incorrect command is sent from the personal computer, the ER401 command will be sent from the projector to the personal computer.



## Technical Information

### Cable specifications

(When connected to a personal computer)

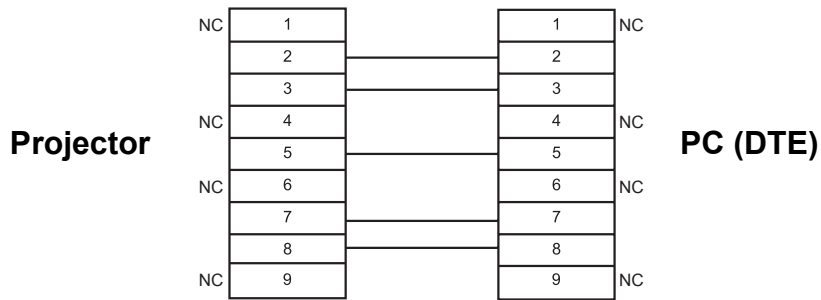

### Control commands

Command	Control contents	Remarks
<b>PON</b>	Power on	In standby mode, all commands other than the PON command are ignored. ● The PON command is ignored during lamp ON control.
<b>POF</b>	Power off	If a PON command is received while the cooling fan is operating after the lamp has switched off, the lamp is not turned back on again straight away in order to protect the lamp.
<b>AVL</b>	Volume	Parameter 000 - 063 (Adjustment value 0 - 63)
<b>IIS</b>	Input	Parameter: VID = VIDEO RG1 = COMPUTER1 SVD = S-VIDEO RG2 = COMPUTER2 NWP = WIRELESS (PT-LB80NTE/PT-LB75NTE only)
<b>Q\$S</b>	Lamp condition query	Call back 0 = Standby 1 = Lamp on control active 2 = Lamp on 3 = Lamp off control active
<b>OSH</b>	AV mute	Turning off the projection and sound temporarily. Send the command to switch between on and off. Do not send the command consecutively.

## Computer connection guidance

You can switch the signals which to output from the **COMPUTER1 OUT** terminal by pressing the computer key command. The key commands are depend on the manufactures. If you select the computer terminals which has no signals while the **INPUT GUIDE** is set to **DETAILED**, the computer connection guidance will be displayed.

Manufacturer	Key command	Manufacturer	Key command	Manufacturer	Key command
Panasonic NEC	<b>Fn</b> + <b>F3</b>	TOSHIBA SHARP HP	<b>Fn</b> + <b>F5</b>	IBM SONY	<b>Fn</b> + <b>F7</b>
				Apple	<b>F7</b>
FUJITSU	<b>Fn</b> + <b>F10</b>	EPSON DELL	<b>Fn</b> + <b>F8</b>	Other	<b>Fn</b> +

#### NOTE:

- The computer connection guidance will disappear after 5 minutes.
- Please refer the instructions which provided with the computers for more detailed information.

## Screen size and throw distance for 16:9 aspect ratio

Projection size (16 : 9)	Throw distance (L) PT-LB80NTE / LB80E		Throw distance (L) PT-LB78E / LB75NTE / LB75E	
	Minimum distance (LW)	Maximum distance (LT)	Minimum distance (LW)	Maximum distance (LT)
33" (0.84 m)		1.2 m (3'11")		1.2 m (3'11")
40" (1.02 m)	1.2 m (3'11")	1.5 m (4'11")	1.3 m (4'3")	1.5 m (4'11")
50" (1.27 m)	1.6 m (5'2")	1.9 m (6'2")	1.6 m (5'2")	1.9 m (6'2")
60" (1.52 m)	1.9 m (6'2")	2.3 m (7'6")	1.9 m (6'2")	2.3 m (7'6")
70" (1.78 m)	2.2 m (7'2")	2.7 m (8'10")	2.2 m (7'2")	2.6 m (8'6")
80" (2.03 m)	2.5 m (8'2")	3.0 m (9'10")	2.5 m (8'2")	3.0 m (9'10")
90" (2.29 m)	2.8 m (9'2")	3.4 m (11'1")	2.8 m (9'2")	3.4 m (11'1")
100" (2.54 m)	3.2 m (10'5")	3.8 m (12'5")	3.2 m (10'5")	3.8 m (12'5")
120" (3.05 m)	3.8 m (12'5")	4.6 m (15'1")	3.8 m (12'5")	4.6 m (15'1")
150" (3.81 m)	4.8 m (15'8")	5.8 m (19')	4.7 m (15'5")	5.7 m (18'8")
200" (5.08 m)	6.4 m (20'11")	7.7 m (25'3")	6.3 m (20'8")	7.6 m (24'11")
250" (6.35 m)	8.0 m (26'2")	9.6 m (31'5")	7.9 m (25'11")	9.5 m (31'2")
300" (7.62 m)	9.6 m (31'5")	11.6 m (38')	9.5 m (31'2")	11.4 m (37'4")

\* All measurements above are approximate and may differ slightly from the actual measurements.

### Calculation methods for screen dimensions

You can calculate more detailed screen dimension from the screen diagonal.

- Screen width (SW) and screen height (SH)

$$SW (m) = SD (") \times 0.0221$$

$$SH (m) = SD (") \times 0.0125$$

- Minimum distance (LW) and maximum distance (LT)

$$PT-LB80NTE: LW (m) = 0.0321 \times SD (") - 0.04 \quad LT (m) = 0.0388 \times SD (") - 0.06$$

$$PT-LB75NTE: LW (m) = 0.0318 \times SD (") - 0.022 \quad LT (m) = 0.0383 \times SD (") - 0.046$$

\* The results above are approximate and may differ slightly from the actual measurements.

## Technical Information

### Specifications

<b>Power supply</b>		AC 100 - 240 V 50 Hz/60 Hz
<b>Power consumption</b>		300 W During standby (when fan is stopped): 4 W
<b>Amps</b>		3.5 A - 1.2 A
<b>LCD panel</b>	<b>Panel size (diagonal)</b>	0.63 type (16.00 mm)
	<b>Aspect ratio</b>	4 : 3
	<b>Display method</b>	3 transparent LCD panels (RGB)
	<b>Drive method</b>	Active matrix method
	<b>Pixels</b>	786 432 (1 024 x 768) x 3 panels
<b>Lens</b>		Manual zoom (1.2x)/Manual focus F 1.6 - 1.9, f 18.8 mm - 22.6 mm (PT-LB80NTE / LB80E) F 1.7 - 1.9, f 18.5 mm - 22.2 mm (PT-LB78E / LB75NTE / LB75E)
<b>Optical axis</b>		8.5:1 fixed (PT-LB80NTE / LB80E) 5:1 fixed (PT-LB78E / LB75NTE / LB75E) (page 17)
<b>Lamp</b>		UHM lamp (220 W)
<b>Luminosity*1</b>		3 200 lm (PT-LB80NTE / LB80E) 3 000 lm (PT-LB78E) 2 600 lm (PT-LB75NTE / LB75E)
<b>Operating environment</b>		Temperature 0 °C - 40 °C (32 °F - 104 °F) When the <b>ALTITUDE</b> (page 37) is set to <b>HIGH</b> : 0 °C - 35 °C (32 °F - 95 °F) Humidity 20% - 80% (no condensation)
<b>Scanning frequency*2 (for RGB signal)</b>	<b>Horizontal scanning frequency</b>	15 kHz - 91 kHz
	<b>Vertical scanning frequency</b>	50 Hz - 85 Hz
	<b>Dot clock frequency</b>	Less than 110 MHz
<b>COMPONENT (YPbPr) signals</b>		525i (480i), 525p (480p), 625i (576i), 625p (576p), 750 (720)/60p, 750 (720)/50p, 1 125 (1 080)/60i, 1 125 (1 080)/50i
<b>Colour system</b>		7 (NTSC/NTSC 4.43/PAL/PAL-M/PAL-N/PAL60/SECAM)
<b>Projection size</b>		33" - 300" (838.2 mm - 7 620 mm)
<b>Throw distance</b>		1.1 m - 11.6 m (3'7" - 38')
<b>Screen aspect ratio</b>		4 : 3
<b>Installation</b>		FRONT/DESK, FRONT/CEILING, REAR/DESK, REAR/CEILING (Menu selection method)
<b>Speaker</b>		1 piece 4 cm x 2 cm (1 - 9/16" x - 25/32")
<b>Max. useable volume output</b>		1.0 W (Monaural)

\*1. Measurement, measuring conditions and method of notation all comply with ISO21118 international standards.

\*2. See "List of compatible signals" on page 46 for available signals.

<b>Terminals</b>	<b>S-VIDEO IN</b>	Single - line, Mini DIN 4p Y: 1.0 V [p-p], C: 0.286 V [p-p], 75 Ω
	<b>VIDEO IN</b>	Single - line, RCA pin jack 1.0 V [p-p], 75Ω
	<b>COMPUTER</b>	Single - line, D - sub HD 15-pin (female) <ul style="list-style-type: none"> <li>● RGB input/output <div style="margin-left: 40px;">R.G.B.: 0.7 V [p-p], 75 Ω</div> <div style="margin-left: 40px;">G SYNC: 1.0 V [p-p], 75 Ω</div> </li> </ul>
		HD, VD/SYNC: TTL high impedance, automatic positive/negative polarity compatible
		<ul style="list-style-type: none"> <li>● YPBPR/YPBCB input/output <div style="margin-left: 40px;">Y: 1.0 V [p-p] (include sync) 75 Ω</div> <div style="margin-left: 40px;">PB/CB, PR/CR: 0.7 V [p-p] 75 Ω</div> </li> </ul>
	<b>AUDIO IN</b>	Single - line, 0.5 V [rms], RCA pin jack x 2 (L - R)
	<b>COMPUTER AUDIO IN</b>	Dual - line, 0.5 V [rms], M3 jack (Stereo MINI)
	<b>VARIABLE AUDIO OUT</b>	Single - line, 0.5 V [rms], M3 jack (Stereo MINI) Monitor output/stereo compatible 0 V [rms] - 2.0 V [rms] (variable)
<b>SERIAL</b>	D-sub 9-pin RS-232C compatible	
<b>Wireless LAN (PT-LB80NTE/PT-LB75NTE only)</b>	<b>Compatible</b>	IEEE802.11b/IEEE802.11g (Wireless LAN standard protocol)
	<b>Wireless channel</b>	IEEE802.11b/IEEE802.11g: 1 - 13 channels
	<b>Distance</b>	30 m (98'5") Depends on the usage environment
<b>Cabinet</b>		Moulded plastic (PC+ABS)
<b>Dimensions</b>	Width	368 mm (14 - 15/32")
	Height	97 mm (3 - 13/16")
	Length	233 mm (9 - 5/32") (not including surface projection parts)
<b>Weight</b>		Approx. 3 kg (6.6 lbs.)* <sup>1</sup>
<b>Certifications</b>		EN60950-1, EN55022, EN61000-3-2, EN61000-3-3, EN55024
<b>Remote control</b>	<b>Power supply</b>	3 V DC (AA battery x 2)
	<b>Operating range</b>	Approx. 15 m (49'2") (when operated directly in front of signal receptor)
	<b>Weight</b>	117 g (4.2 ozs.) (including batteries)
	<b>Dimensions</b>	Width
Length		163 mm (6 - 13/32")
Height		24.5 mm (-15/16") (not including surface projection parts)
<b>Options</b>	<b>Ceiling bracket</b>	ET-PKB80

\*1. Average value. Each product has an individual variability in weight.

## Technical Information

### Dimensions

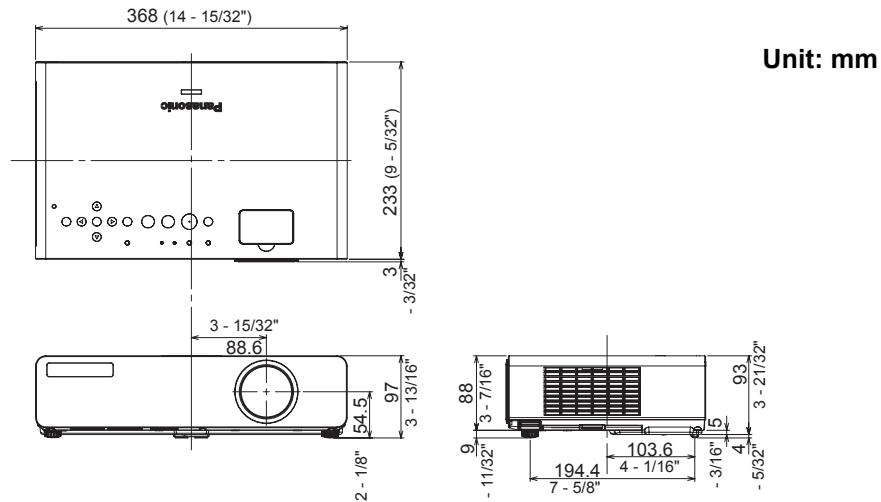

### Trademark acknowledgements

- VGA and XGA are trademarks of International Business Machines Corporation.
- S-VGA is a registered trademark of the Video Electronics Standards Association.
- HDMI, the HDMI logo and High-Definition Multimedia Interface are trademarks or registered trademarks of HDMI Licensing LLC.
- The font used in the on-screen displays is a Ricoh bitmap font, which is manufactured and sold by Ricoh Company, Ltd.

All other trademarks are the property of the various trademark owners.

# Index

<b>A</b>		
AC IN .....	15	
Accessories .....	12	
Air exhaust port .....	15	
Air filter		
Cleaning .....	42	
Compartment .....	15	
Air intake port .....	14	
ALTITUDE .....	37	
Ambient Luminance Sensor (ALS) .....	14	
ASPECT .....	34	
AUDIO BALANCE .....	38	
AUDIO IN .....	15	
AUTO SETUP		
Menu .....	37	
Remote control .....	25	
Remote control button .....	16	
AV MUTE		
Remote control .....	26	
Remote control button .....	16	
<b>B</b>		
BACK COLOR .....	38	
Batteries .....	12	
Battery compartment .....	16	
BLACKBOARD .....	38	
BRIGHTNESS .....	32	
Burglar hook port .....	15	
<b>C</b>		
Calculation methods		
16:9 .....	49	
4:3 .....	17	
Carrying bag .....	12	
CD-ROM		
Accessories .....	12	
Cleaning		
Air filter .....	42	
Projector .....	42	
CLOCK PHASE .....	34	
COLOR .....	32	
COLOR TEMPERATURE .....	32	
COMPUTER		
Connection guidance .....	48	
Remote control .....	26	
Remote control button .....	16	
COMPUTER AUDIO IN .....	15	
COMPUTER SEARCH .....	16	
COMPUTER1 IN .....	15	
COMPUTER2 IN/1 OUT .....	15	
COMPUTER2 SELECT .....	36	
Connections .....	19	
CONTRAST .....	32	
CONTROL PANEL		
Buttons .....	14	
Menu .....	37	
<b>D</b>		
DAYLIGHT VIEW .....	32	
DEFAULT		
Remote control .....	26	
Remote control button .....	16	
DETAILED SETUP		
OPTION menu .....	38	
PICTURE menu .....	33	
DIGITAL ZOOM		
Remote control .....	28	
Remote control button .....	16	
Dimensions .....	52	
Direct power off .....	20	
DIRECT POWER ON		
Function .....	20	
Menu .....	37	
DOT CLOCK .....	34	
<b>E</b>		
ENTER		
Control panel button .....	14	
Remote control button .....	16	
<b>F</b>		
Focus ring .....	14, 24	
FRAME LOCK .....	35	
FREEZE		
Remote control .....	26	
Remote control button .....	16	
Front leg adjusters .....	15, 18, 24	
Buttons .....	24	
FUNCTION		
Control panel button .....	14	
FUNCTION BUTTON .....	38	
Remote control .....	27	
Remote control button .....	16	
<b>H</b>		
Hand strap .....	16	
<b>I</b>		
INDEX-WINDOW		
Remote control .....	27	
Remote control button .....	16	
INITIALIZE ALL .....	38	
INPUT GUIDE .....	36	
INPUT PASSWORD .....	39	
INPUT SELECT		
Control panel button .....	14	
Remote control button .....	16	
Selecting .....	26	
INSTALLATION		
Menu .....	37	
Projection method .....	18	
<b>K</b>		
KEYSTONE .....	34	
<b>L</b>		
LAMP		
Indicator .....	14	
Indicator status .....	41	
LAMP POWER .....	37	
LAMP RUNTIME .....	37, 44	
Lamp unit compartment .....	15	
Replacing .....	43	
<b>M</b>		
Mains lead		
Accessories .....	12	
Connecting .....	20	
MENU		
Control panel button .....	14	
Main menu .....	30	
Navigation .....	29	
Remote control .....	29	
Remote control button .....	16	
MULTI-LIVE .....	16	

# Index

<b>N</b>		S-VIDEO IN ..... 15
Navigation buttons		SXGA MODE ..... 38
Control panel button ..... 14		<b>T</b>
Remote control button ..... 16		Technical Information ..... 46
NOISE REDUCTION ..... 33		TEMP
<b>O</b>		Indicator ..... 14
OPTION menu ..... 36		Indicator status ..... 41
OSD DESIGN ..... 38		TEST PATTERN ..... 38
<b>P</b>		TEXT CHANGE ..... 39
PAGE ..... 16		TEXT DISPLAY ..... 39
PASSWORD CHANGE ..... 39		Throw distance
PICTURE menu ..... 32		16:9 ..... 49
PICTURE MODE ..... 32		4:3 ..... 17
POSITION ..... 34		Throwing angle ..... 18
POSITION menu ..... 34		TINT ..... 32
POWER		Troubleshooting ..... 45
Control panel ..... 14		TV-SYSTEM ..... 33
Indicator ..... 14		<b>V</b>
Indicator status ..... 23		VARIABLE AUDIO OUT ..... 15
Remote control button ..... 16		VIDEO
Power cord secure lock ..... 12, 20		Remote control ..... 26
POWER LOCK		Remote control button ..... 16
Indicator ..... 14		VIDEO IN ..... 15
Indicator status ..... 23		VOLUME ..... 38
POWER OFF TIMER ..... 37		Remote control ..... 27
Projection method ..... 18		Remote control button ..... 16
<b>R</b>		<b>W</b>
REALTIME KEYSTONE ..... 34		WHITE BALANCE ..... 33
RELEASE		WIDE MODE ..... 36
Control panel button ..... 14		WIRELESS
Remote control		Menu ..... 40
Accessories ..... 12		Remote control ..... 26
Operation ..... 25		Remote control button ..... 16
Signal emitter ..... 16		<b>Z</b>
Signal receptor ..... 14, 15		Zoom ring ..... 14, 24
Replacing		Zoom-Focus ring cover ..... 14
Air filter ..... 42		
Lamp unit ..... 43		
RETURN		
Control panel button ..... 14		
Remote control ..... 29		
Remote control button ..... 16		
RGB/YPBPR ..... 36		
<b>S</b>		
Screen size		
16:9 ..... 49		
4:3 ..... 17		
Security ..... 11		
Security lock ..... 15		
SECURITY menu ..... 39		
SERIAL ..... 15		
Basic format ..... 47		
Cable specifications ..... 48		
Communication settings ..... 47		
Connection ..... 47		
Control commands ..... 48		
Pin assignments ..... 47		
SHARPNESS ..... 32		
SIGNAL SEARCH ..... 37		
Signals ..... 46		
Speaker ..... 15		
Specifications ..... 50		
STARTUP LOGO ..... 36		
STILL MODE ..... 33		
Sub-menu ..... 30		





---

# Panasonic Corporation

Web Site : <http://panasonic.net/avc/projector/>  
© Panasonic Corporation 2009

Printed in Japan  
S0308-5039F(P)  
TQBJ0245-3

