



LCD

Projector

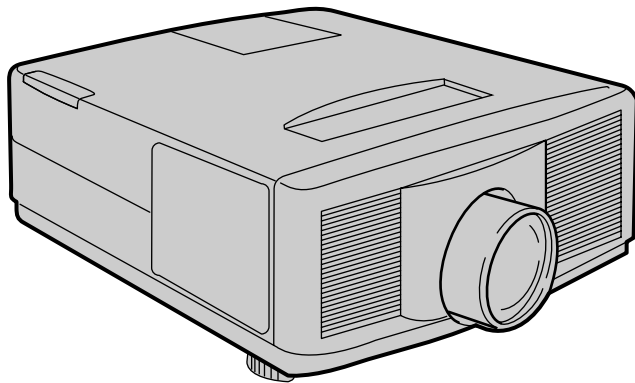

Owner's

Guide

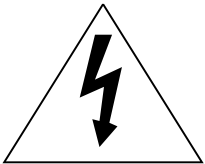

X100

MODEL LVP-X100A

	CAUTION RISK OF ELECTRIC SHOCK DO NOT OPEN	
<p>CAUTION: TO REDUCE THE RISK OF ELECTRIC SHOCK, DO NOT REMOVE COVER (OR BACK) NO USER-SERVICEABLE PARTS INSIDE REFER SERVICING TO QUALIFIED SERVICE PERSONNEL.</p>		



The lightning flash with arrowhead symbol, within an equilateral triangle, is intended to alert the user to the presence of uninsulated “dangerous voltage” within the product’s enclosure that may be of sufficient magnitude to constitute a risk of electric shock.



The exclamation point within an equilateral triangle is intended to alert the user to the presence of important operating and maintenance (servicing) instructions in the literature accompanying the appliance.

WARNING:

TO PREVENT FIRE OR SHOCK HAZARD, DO NOT EXPOSE THIS APPLIANCE TO RAIN OR MOISTURE.

CAUTION:

TO PREVENT ELECTRIC SHOCK DO NOT USE THIS (POLARIZED) PLUG WITH AN EXTENSION CORD, RECEPTACLE OR OTHER OUTLET UNLESS THE BLADES CAN BE FULLY INSERTED TO PREVENT BLADE EXPOSURE.

NOTE:

SINCE THIS PROJECTOR IS PLUGGABLE EQUIPMENT, THE SOCKET-OUTLET SHALL BE INSTALLED NEAR THE EQUIPMENT AND SHALL BE EASILY ACCESSIBLE.

COMPLIANCE NOTICE OF FCC

This equipment has been tested and found to comply with the limits for a Class A digital device, pursuant to Part 15 of the FCC Rules. These limits are designed to provide reasonable protection against harmful interference when the equipment is operated in a commercial environment. This equipment generates, uses, and can radiate radio frequency energy and, if not installed and used in accordance with the instruction manual, may cause harmful interference to radio communications. Operation of this equipment in a residential area is likely to cause harmful interference in which case the user will be required to correct the interference at his own expense.

This digital apparatus does not exceed the Class A limits for radio noise emissions from digital apparatus as set out in the interference-causing equipment standard entitled "Digital Apparatus", ICES-003 of the Department of Communications.

Changes or modifications not expressly approved by Mitsubishi could void the user's authority to operate this equipment.

COMPLIANCE NOTICE OF INDUSTRY CANADA

This Class [A] digital apparatus meets all requirements of the Canadian Interference-Causing Equipment Regulations.

WARNING

Use the attached specified power-supply cord. If you use another cord, it may cause interference with radio and television reception.

Use the attached VGA cable, RS-232C cable with this equipment so as to keep interference within the limit of a Class A device.

The projector automatically shuts off when the lamp is used up in about 1,300 hours and not used until lamp replacement.

DO NOT LOOK DIRECTLY INTO THE LENS WHEN PROJECTOR IS IN THE POWER ON MODE.

Contents

Important safeguards	5
Overview of the projector	8
Overview of the remote control	12
Battery installation	13
Preparing the projector for operation	14
Basic connections	16
Cables and adapters	17
Projector + IBM PC or IBM PC compatibles (DOS)	18
Projector + Macintosh	19
Projector + NEC PC-98 and EPSON PC series	20
Projector + AV equipment	21
To operate projector power ON	22
Menu operation	24
MENU layers	24
Basic operation	25
NORMAL menu	26
GAMMA CORRECTION menu	27
ENHANCED menu	28
POINTER menu	30
AUDIO menu	30
OPTION menu	31
USER PRESET menu	32
Advanced feature for presentation	33
Cursor operation	33
Expand	34
Super impose	35
PC-CARD	36
Advanced feature with PC	38
PCV	39
PCGC	42
SpacePointer	45
Maintenance	47
Replacing the lamp	48
Indicators	50
Troubleshooting	51
Specifications	53
Replacement parts list	54

Trademark, Registered trademark

Apple, Macintosh are registered trademarks of Apple Computer Inc.

IBM, VGA, PS/2, OS/2 are trademarks or registered trademarks of International Business Machines Corporation.

Microsoft®, Windows®, Windows® 95, Windows NT® are registered trademarks of Microsoft in the U.S. and other countries.

SpacePointer® is a registered trademark of ALPS ELECTRIC CO., LTD.

Other brand or product names are trademarks or registered trademarks of their respective holders.

Important safeguards

PLEASE READ ALL THESE INSTRUCTIONS REGARDING YOUR LCD PROJECTOR AND RETAIN THEM FOR FUTURE REFERENCE. FOLLOW ALL WARNINGS AND INSTRUCTIONS MARKED ON THE LCD PROJECTOR.

1. **Read instructions**
All the safety and operating instructions should be read before the appliance is operated.
2. **Retain instructions**
The safety and operating instructions should be retained for future reference.
3. **Warnings**
All warnings on the appliance and in the operating instructions should be adhered to.
4. **Instructions**
All operating instructions must be followed.
5. **Cleaning**
Unplug this projector from the wall outlet before cleaning it. Do not use liquid aerosol cleaners. Use a damp cloth for cleaning.
6. **Attachments and equipment**
Never add any attachments and/or equipment without the approval of the manufacturer as such additions may result in the risk of fire, electric shock or other personal injury.
7. **Water and moisture**
Do not use this projector near water or in contact with water.
8. **Accessories**
Do not place this projector on an unstable cart, stand, tripod, bracket or table. Use only with a cart, stand, tripod bracket, or table recommended by the manufacturer or sold with the projector. Any mounting of the appliance should follow the manufacturer's instructions and should use a mounting accessory recommended by the manufacturer.

An appliance and cart combination should be moved with care. Quick stops, excessive force and uneven surfaces may cause the appliance and cart combination to overturn.



Important safeguards (continued)

9. **Ventilation**
Slots and openings in the cabinet are provided for ventilation, ensuring reliable operation of the projector and to protect it from overheating. Do not block these openings or allow them to be blocked by placing the projector on a bed, sofa, rug, or bookcase. Ensure that there is adequate ventilation and that the manufacturer's instructions have been adhered to.
10. **Power sources**
This projector should be operated only from the type of power source indicated on the marking label. If you are not sure of the type of power supplied to your office, consult your appliance dealer or local power company.
11. **Power-cord protection**
Power-supply cords should be routed so that they are not likely to be walked on or pinched by items placed upon or against them. Pay particular attention to cords at plugs, convenience receptacles, and points where they exit from the appliance.
12. **Overloading**
Do not overload wall outlets and extension cords as this can result in a fire or electric shock.
13. **Object and liquid entry**
Never push objects of any kind through openings of this projector as they may touch dangerous voltage points or short-out parts that could result in a fire or electric shock. Never spill liquid of any kind on the projector.
14. **Servicing**
Do not attempt to service this projector yourself as opening or removing covers may expose you to dangerous voltage or other hazards. Refer all servicing to qualified service personnel.
15. **Damage requiring service**
Unplug this projector from the wall outlet and refer servicing to qualified service personnel under the following conditions:
 - (a) If the power-supply cord or plug is damaged.
 - (b) If liquid has been spilled, or objects have fallen into the projector.
 - (c) If the projector does not operate normally after you follow the operating instructions. Adjust only those controls that are covered by the operating instructions. An improper adjustment of other controls may result in damage and may often require extensive work by a qualified technician to restore the projector to its normal operation.
 - (d) If the projector has been exposed to rain or water.
 - (e) If the projector has been dropped or the cabinet has been damaged.
 - (f) If the projector exhibits a distinct change in performance - this indicates a need for service.
16. **Replacement parts**
When replacement parts are required, be sure that the service technician has used replacement parts specified by the manufacturer or parts having the same characteristics as the original part. Unauthorized substitutions may result in fire, electric shock or other hazards.
17. **Safety check**
Upon completion of any service or repair to this projector, ask the service technician to perform safety checks determining that the projector is in a safe operating condition.

WARNING:

Unplug immediately if there is something wrong with your projector.

Do not operate if smoke, strange noise or odor comes out of your projector. It might cause fire or electric shock. In this case, unplug immediately and contact your dealer.

Never remove the cabinet.

This projector contains high voltage circuitry. An inadvertent contact may result in an electric shock. Except as specifically explained in the Owner's Guide, do not attempt to service this product yourself. Please contact your dealer when you want to fix, adjust or inspect the projector.

Do not modify this equipment.

It can lead to fire or electric shock.

If you break or drop the cabinet.

Do not keep using this equipment if you break or drop it. Unplug the projector and contact your dealer for inspection. It may lead to fire if you keep using the equipment.

Do not face a lens to the sun.

It can lead to fire.

Use correct voltage.

If you use incorrect voltage, it can lead to fire.

Do not place the projector on uneven surface. Level stable surface only.

Please do not place equipment on unstable surfaces.

Do not look into a lens.

Do not look into the lens when it is operating. It may hurt your eyes.

Never let children look into the lens when it is on.

Do not turn off the main power abruptly or unplug the projector during operation.

It can lead to lamp breakage, fire, electric shock or other trouble.

Place of installation

Refrain from setting the projector at any place subjected to high temperature and high humidity. Precision devices are built into the projector. Please maintain an operating temperature, humidity, and altitude as specified below for safety's sake.

- Operating temperature: between +41°F (+5°C) and +95°F (+35°C)
- Operating humidity: between 30 and 90%
- Never put any heat-producing device under the projector so that the projector does not overheat.
- Do not attach the projector to a place that is unstable or subject to vibration.
- Do not install the projector near any equipment that produces a strong magnetic field. Also refrain from installing near the projector any cable carrying a large current.
- Place the projector on a solid, vibration free surface: otherwise it may fall, causing serious injury to a child or adult, and serious damage to the product.
- Do not stand the projector: it may fall, causing serious injury and damage to the projector.

Overview of the projector

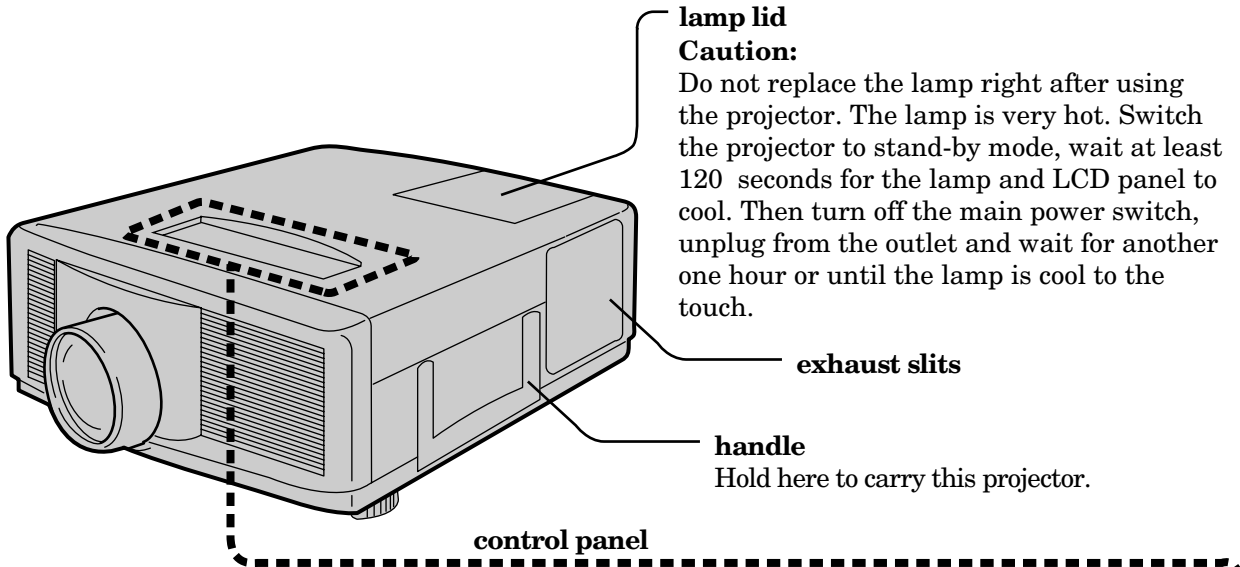

temperature indicator

This informs you of the thermal condition inside the projector. When the inside temperature is extremely high, the power automatically shuts off while the indicator blinks red. See page 49.

lamp indicator

This informs you of the status of the light source lamp and its service life. When the projector lamp is lit, the indicator lights up in green. This indicator blinks red when the service life of the lamp is about to expire (about 1,000 hours). When the lamp is used up to 1,300 hours, the projector automatically shuts off. See pages 22 & 49.

The projector automatically shuts off when the lamp is used up in about 1,300 hours and not used until lamp replacement.

power indicator

When the main power switch is on in stand-by mode, this indicator lights up red. When the projector is fully "ON", the indicator lights up green. See pages 22 & 49.

power

Use to turn the projector on or off when MAIN POWER is on. To turn the projector off, press this button twice. See page 22.

input source (input)

Use to select the input source you wish to watch. See page 23.

freeze / capture

Use to freeze the image. When the PC card is inserted, you can record the "frozen" image. Press one time to freeze. For the second time hold for 5 seconds to record the image into the card. See page 36.

expand / PinP

Use to change the mode, EXPAND, NATIVE or PinP (Picture in Picture). See pages 23, 34 & 35.

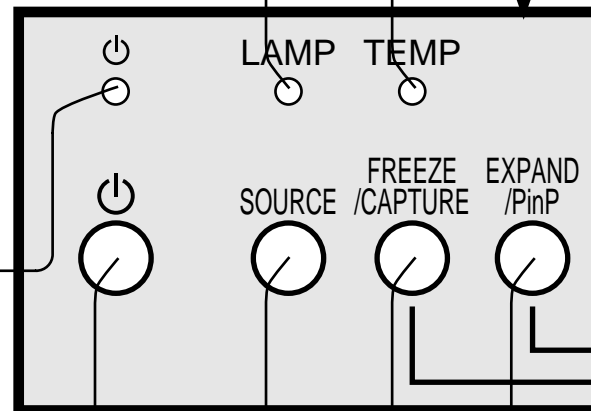

FINE, ADJUST, FOCUS/ZOOM and AUTO buttons

The operations of these buttons vary as follows depending on the modes selected:

	FINE (<)	FINE (>)	∨	∧	FOCUS / ZOOM	AUTO
Normal	Adjust FINE (-)	Adjust FINE(+)	Adjust FOCUS or ZOOM (-)	Adjust FOCUS or ZOOM (+)	FOCUS or ZOOM setting	Adjust position when incorrect
On Menu	Select the setting item (Left)	Select the setting item (Right)	Set or select the setting (Down)	Set or select the setting (Up)	Enter the layer setting	-
On PC card Menu	Select the image (Left)	Select the image (Right)	Select the image (Down)	Select the image (Up)	Select the directory (-)	Select the directory (+)
PinP	-	-	Switch still pictures (main or sub)	Switch still pictures (main or sub)	Recapture of the still image	Select the input source of PinP
EXPAND	Expand different area (Left)	Expand different area (Right)	Expand different area (Down)	Expand different area (Up)	Set the expand rate (-)	Set the expand rate (+)

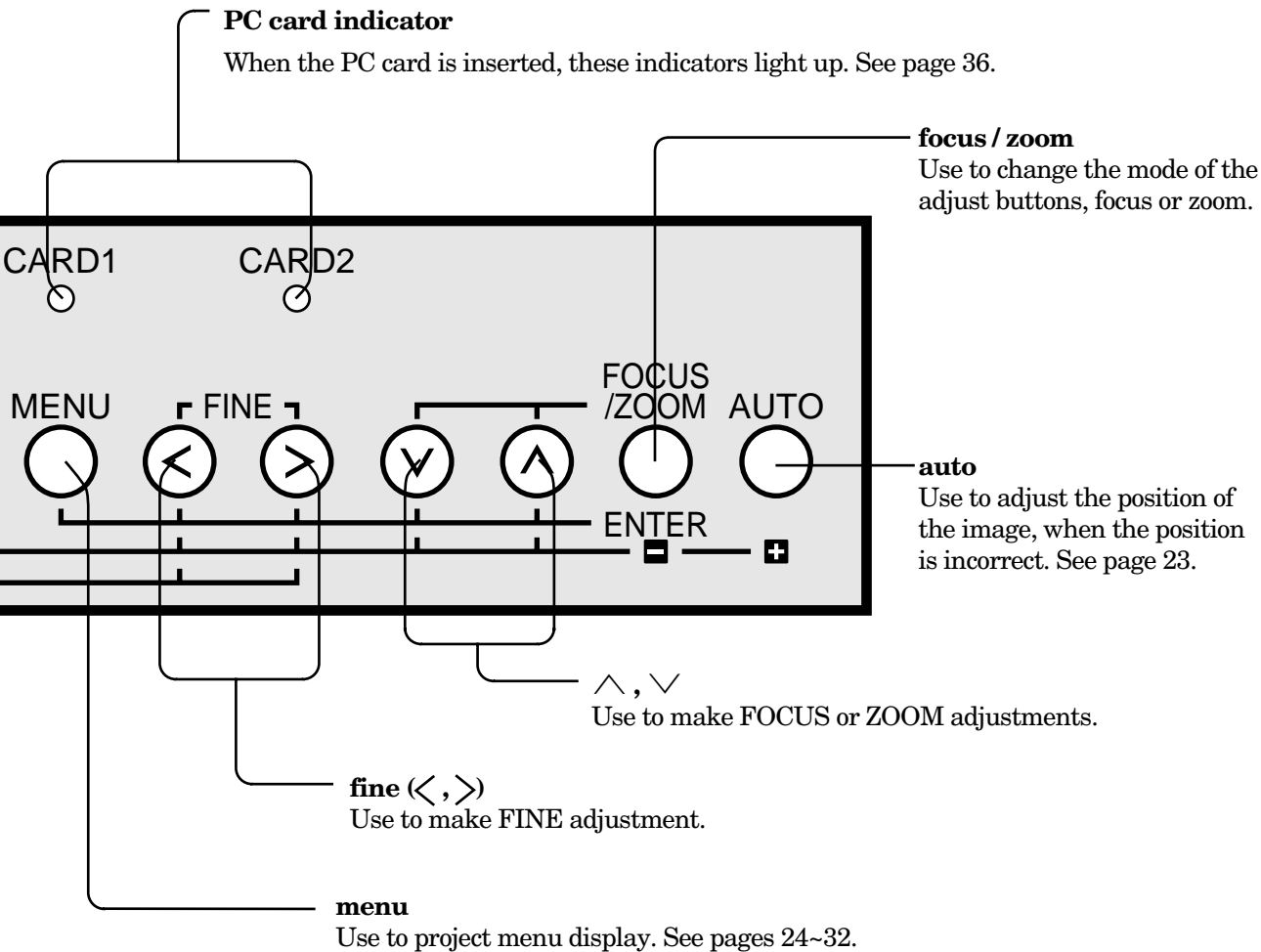

Overview of the projector (continued)

Left side

PC card eject
Press to eject the PC card.
See page 36.

PC card insert slot
This is where you insert the PC card.
(You can insert up to two cards.)
See page 36.

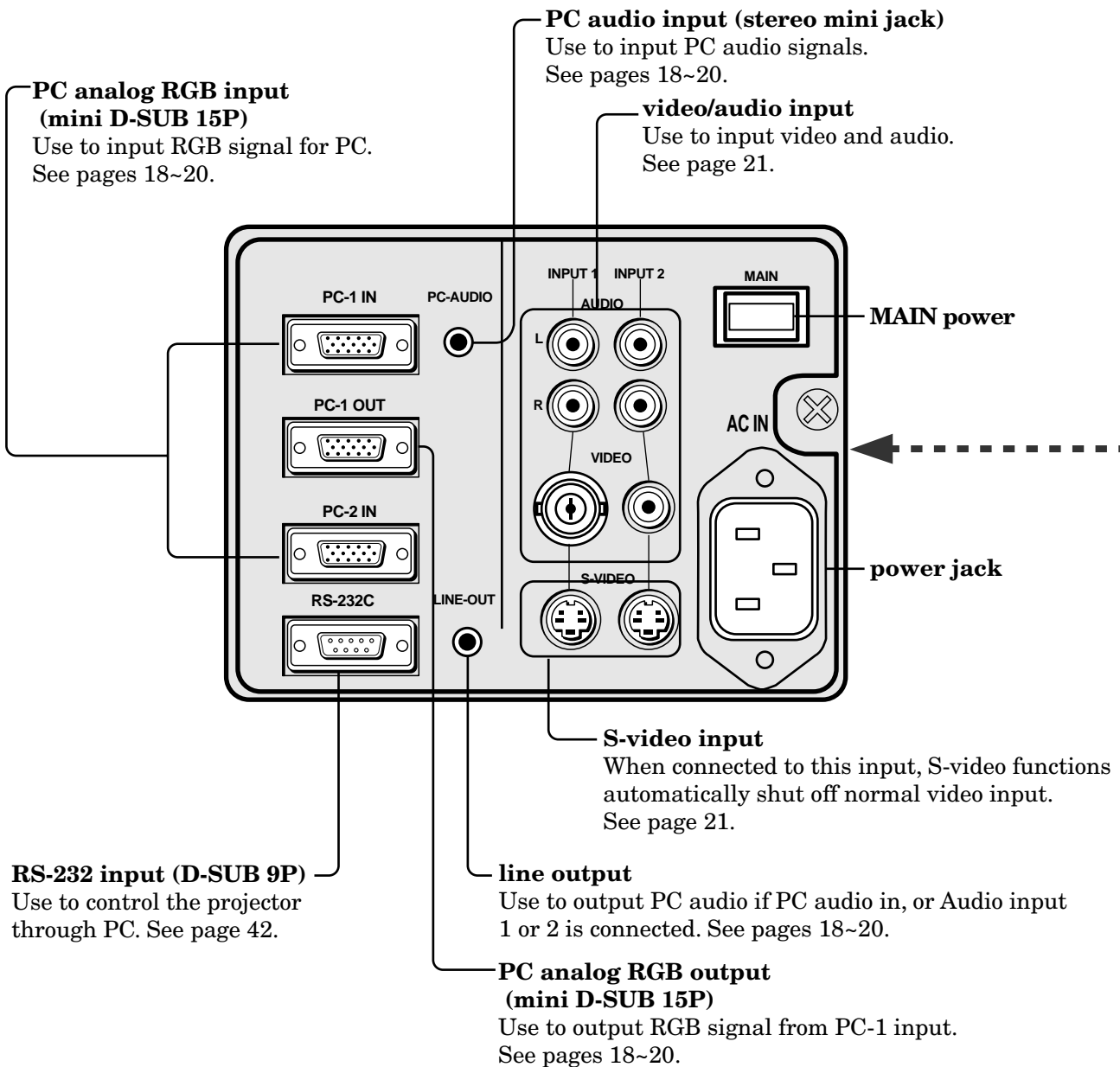
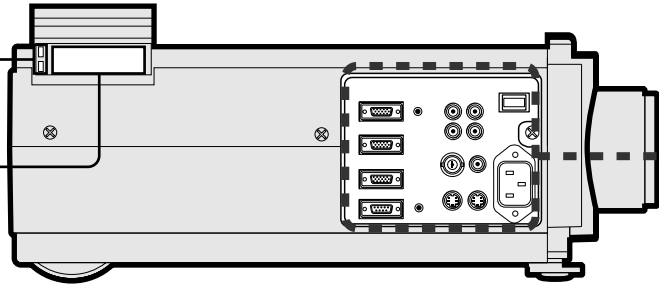

PC analog RGB input

Use to input video signals (analog RGB) of a personal computer.

(Pin assignment of Mini D-SUB 15P jack)

PIN NO.	SPEC	PIN NO.	SPEC
1	R(RED) / Cr	9	-
2	G(GREEN) / Y	10	GROUND
3	B(BLUE) / Cb	11	GROUND
4	GROUND	12	-
5	GROUND	13	HD/CS
6	GROUND	14	VD
7	GROUND	15	-
8	GROUND		

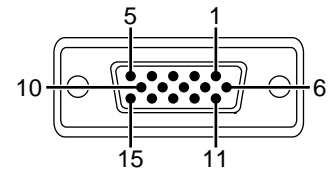

RS-232C input

- Connect here when you control this Projector with a personal computer using PCGC (personal computer graphic controller) or with a remote controller using SpacePointer function.
- The Pin assignment is DTE (Data Terminal Equipment) type.
- Please use RS-232C crossover cable provided.

(Pin assignment of D-SUB 9P jack)

PIN NO.	CODE	NAME	I/O	NOTE
1	CD	Carrier Detect	INPUT	not connected
2	RD	Receive Data(RXD)	INPUT	connected to inner circuit
3	SD	Send Data(TXD)	OUTPUT	connected to inner circuit
4	ER	Equipment Ready(DTR)	OUTPUT	connected to inner circuit
5	SG	Signal Ground		connected to inner circuit
6	DR	Data Set Ready(DSR)	OUTPUT	connected to inner circuit
7	RS	Request to Send(RTS)	OUTPUT	connected to inner circuit
8	CS	Clear to Send(CTS)	INPUT	connected to inner circuit
9	CI	Ring Indicator	INPUT	not connected

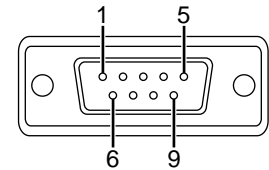

Bottom side

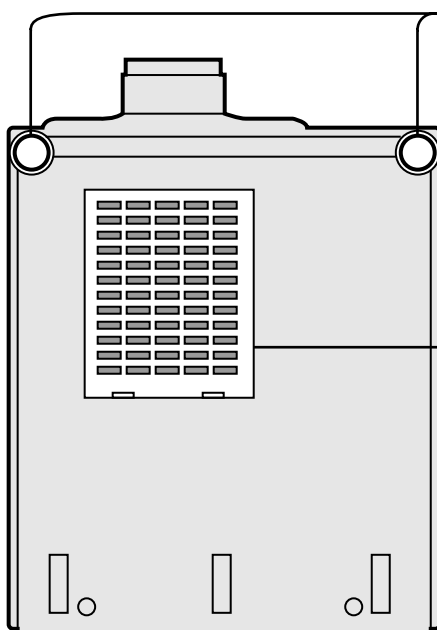

foot adjustment

Use to adjust the angle of the projector.
See page 15.

Note: Be sure to retract them when packing up the projector.

ventilation slots

Used to protect the projector from overheating.
See page 47.

ventilation air filter

This prevents dust from entering inside the projector. See page 47.

Overview of the remote control

operation indicator

When the operation button is pressed, this indicator blinks. When the PC mode or cursor operation mode is on, this indicator lights up. See pages 33, 45.

select

This operates in the same way as the left button on the computer mouse. See pages 33, 45.

double click

This operates in the same way as double clicking the left button on the computer mouse. See pages 33, 45.

power

Use to turn the projector on or off when MAIN POWER is on. To turn the projector off, press this button twice. See page 22.

focus / zoom

Use to change the mode of the ▲ or ▼ buttons, FOCUS or ZOOM. See page 23.

expand

Use to expand the image. See page 34.

capture

Use to freeze the image. When the PC card is inserted, you can record the image. See page 36.

icon

Press to display the icon menu. See page 33.

auto

Use to adjust the position of the image. See page 23.

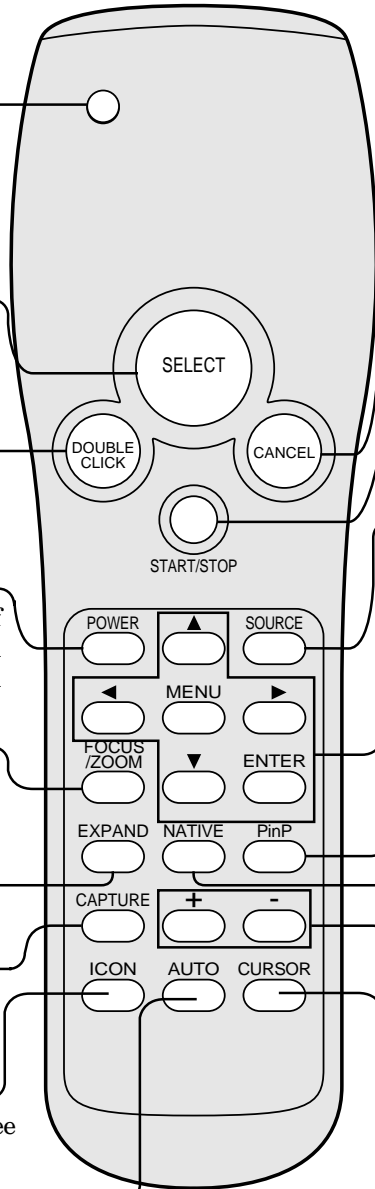

cancel

This operates in the same way as the right button on the computer mouse. See pages 33, 45.

start/stop

Use to turn the PC control mode or cursor operation mode on or off. See pages 33, 45.

input source (input)

Use to select the input source you wish to watch. See page 23.

menu, enter, ▲, ▼, ◀, ▶

Used for MENU setting (see page 25), and used to make FOCUS, ZOOM or FINE adjustments. See the table as shown below.

PinP

Press to turn on the PinP (Picture in Picture) image, or to cancel it. See page 35.

native

Press to change the size of the image to native or full screen. See page 16.

adjust - / +

See the table as shown below.

cursor

Press to display the cursor. Also used to change the mode of PC control or cursor operation, when the projector is connected to a personal computer with RS-232C. See pages 33, 45.

The operations of these buttons varies as follows depending on the modes selected:

	◀	▶	▼	▲	adjust -	adjust +
Normal	Adjust FINE (-)	Adjust FINE(+)	Adjust FOCUS or ZOOM (-)	Adjust FOCUS or ZOOM (+)	-	-
On Menu	Select the setting item (Left)	Select the setting item (Right)	Set or select the setting (Down)	Set or select the setting (Up)	-	-
On PC card Menu	Select the image (Left)	Select the image (Right)	Select the image (Down)	Select the image (Up)	Select the group (-)	Select the group (+)
PinP	-	-	Switch still pictures (main or sub)	Switch still pictures (main or sub)	Recapture of the still picture	Select the input source of PinP
EXPAND	Expand different area (Left)	Expand different area (Right)	Expand different area (Down)	Expand different area (Up)	Set the expand rate (-)	Set the expand rate (+)

Important:

- The select, double click, cancel and start/stop buttons are used for PC control. See page 45.
- To save battery power, turn off the operation indicator by pressing the START/STOP button when not in use.
- To save battery power, the operation indicator will turn off if the remote control is not operated for a period of 5 minutes.

Battery installation

Use two AA size batteries.

1. Remove the back cover of the remote control by pushing the battery compartment door in the direction of the arrow.
2. Load the batteries making sure that they are positioned correctly (+ to +, and - to -).
3. Replace the back cover.

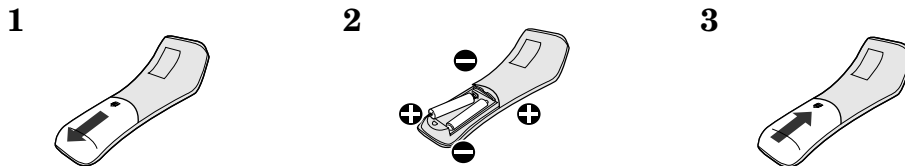

Important:

1. Do not use a new battery with an old one.
2. Load batteries in the correct position.
3. Do not heat, take apart, or throw batteries into fire.
4. Do not try to recharge batteries. Do not use rechargeable batteries.
5. If the alkaline solution of alkaline batteries comes in contact with your skin or clothes, rinse with water. If the solution comes in contact with your eyes, rinse them with water and then consult your doctor.

Operation with remote control for PC mode or cursor operation mode

To move the cursor, press the START/STOP button to ON and move the head of the remote control in the direction you want the cursor to move. This remote control gives you complete 360° control of the cursor direction.

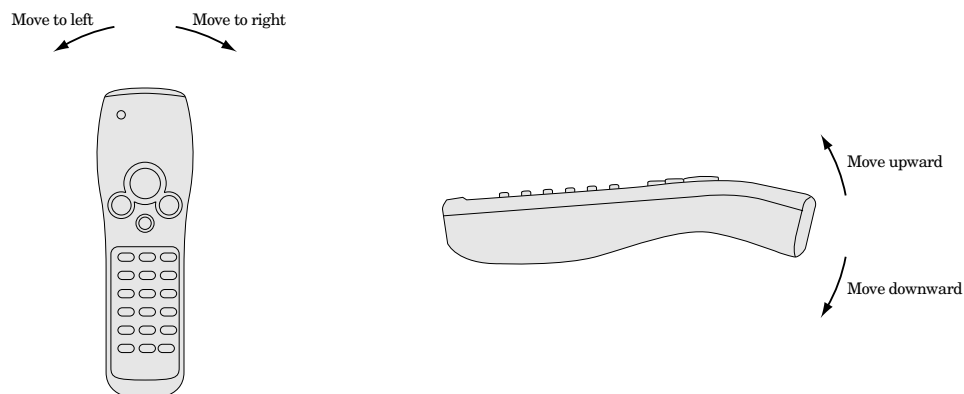

Important:

Point the remote control at the projection screen or at the front or rear of the projector. The range for optimum operation is about 25 feet. If you point the remote at the projection screen, the distance to the screen and back to the projector must be less than 25 feet.

Preparing the projector for operation

Orientation of the projector

Picture size can be set by changing the distance between the screen and the projector.

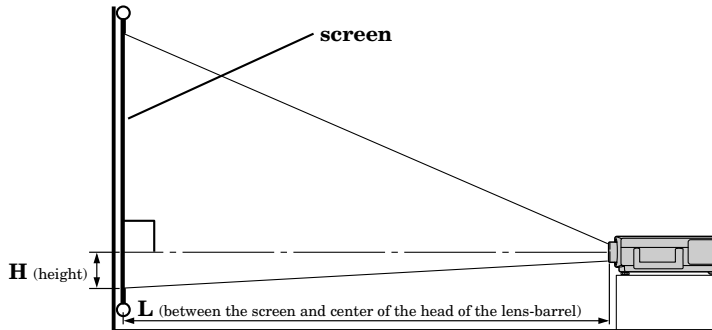

To find the approximate distance between the projector and screen:
 Multiply the width of the screen x 1.85 ~ 1.95 (max.) ,
 Multiply the width of the screen x 2.33 ~ 2.53 (min.) ,
 • Refer to the chart to recommended distances in maximum zoom and minimum zoom.

Screen			Distance from screen (L) / (inches) (approximate)		Height projected image (H) / (inches) (approximate)
Diagonal size (inch)	Height inches (inch)	Width feet (inch)	Maximum zoom (min.)	Minimum zoom (max.)	
20 "	12 "	16"	—	37"	1.5"
40 "	24 "	32 "	59"	78"	3.0"
60 "	36 "	48 "	91"	119"	4.5"
80 "	48 "	64 "	122"	160"	6.0"
100 "	60 "	80 "	154"	201"	7.5"
120 "	72 "	96 "	185"	242"	9.0"
140 "	84 "	112 "	217"	283"	10.5"
160 "	96 "	128 "	248"	324"	12.0"
180 "	108 "	144 "	280"	365"	13.5"
200 "	120 "	160 "	311"	406"	15.0"
300 "	180 "	240 "	468"	—	22.5"

Caution:

- Placing the projector on a carpet reduces ventilation from the fan on the bottom and might cause problems. Place a hard board or similar item under the projector to facilitate ventilation of the unit.
- Place the projector more than 8 in. from the wall to prevent blocking the intake, exhaust slots and ventilation of this projector because hot air comes out of it.
- Do not use the projector under the following circumstances, which may cause fire or electric shock.
 - in a dusty or humid place
 - while the projector is lying sideways or upside down.
 - near a heater
 - in a kitchen or oily, smoky or damp place
 - in direct sunlight
 - where the temperature is lower than 41°F or higher than 95°F

Important:

- Do not put stress on the lens or focus ring, as this may damage them.
- Keep your room dark while using the projector. The image cannot be seen clearly in a bright place.

Adjusting the angle of projection

- Screen on a flat wall with a 90° angle to the floor.
- Align projector to produce a full screen display as illustrated on page 14.
- Distance from projector to screen must be compatible with screen size chart on page 14. Note distance from screen chart.
- If image is not square on screen, try adjusting the front feet of the projector for proper angle.

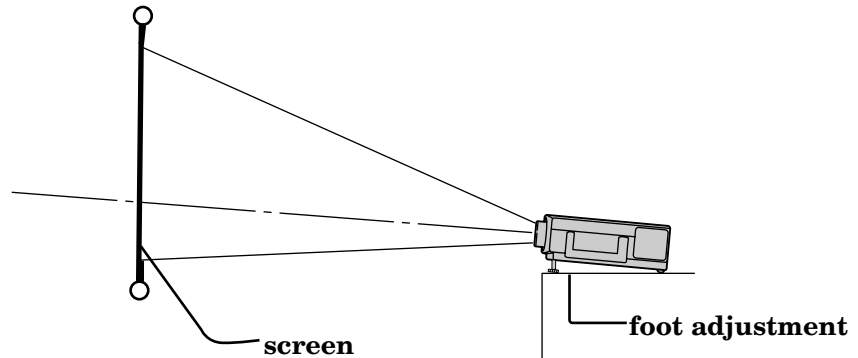

Getting ready for projection

1. Connect the power cord provided to this projector with the power jack of the projector.
2. Connect the power cord to the wall outlet.

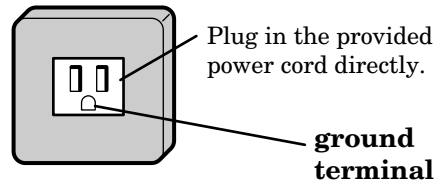

3. Take off the lens cap.
4. Do not look directly into the lens when projector is "ON".

Warning:

- A three-pin grounding type power plug is used with the projector. Do not remove the grounding pin on the power plug. If you are unable to insert the plug into the outlet, contact your electrician to replace your obsolete outlet.
- The supplied power cord is used for 120V only. Never connect to any outlet or power supply having a different voltage or frequency. If you connect to the power supply having a different voltage, please use the appropriate power cord.
- Do not place an object on the power cord and keep the projector away from heat source to avoid breaking the power cord. A broken power cord can cause fire or electric shock.
- Do not revise or alter the power cord otherwise it may cause fire or electric shock. Contact your dealer if the cord is broken.

Caution:

- Plug in firmly and unplug by holding the plug, not by pulling the cable out.
- Do not plug in or out with wet hands. It may cause an electric shock.

Basic connections

This projector can be connected to equipment such as VCRs, video cameras, videodisc players, and personal computers having analog RGB input.

Important:

- Make sure that your equipment is turned off before connection.
- Match the color of video and audio plugs on the AV cable with each terminal.
- Plug in firmly and unplug by holding the plug, not by pulling the cable out.
- If connected units are set too close to one another, the image may be affected. Setting connected units too close to one another affects the image.
- Refer to the owner's guide of each component for details of connections, .

To connect to IBM PC or IBM PC compatibles.

To connect to Macintosh.

To connect to the series of PC-98, EPSON PC.

To connect to AV equipment.

Specification of RGB signals in each computer mode of this projector

signal mode	example of usable computer	resolution (H × V)	horizontal frequency (KHz)
AT (VGA)	DOS machine	640 × 480	60, 72, 75, 85
MAC (13 inch mode)	Apple Macintosh	640 × 480	67
MAC (16 inch mode)	Apple Macintosh	832 × 624	75
MAC (19 inch mode)	Apple Macintosh	1024 × 768	75
MAC (21 inch mode)	Apple Macintosh	1152 × 870	75
PC98	NEC PC98	640 × 400	56, 70
SVGA	Video card etc.	800 × 600	56, 60, 72, 75, 85
XGA	Video card etc.	1024 × 768	43, 60, 70, 75, 85
SXGA	Video card etc.	1152 × 864	70, 75, 85
SXGA	Video card etc.	1280 × 960	60, 75
SXGA	Video card etc.	1280 × 1024	60, 72, 75

- The projector is not compatible with SYNC on G (Green) of an SXGA signal.
- The projector is not compatible with an SXGA signal increased by the interlacing method.
- The picture with a SYNC on G (Green) signal may be tinged with green.
- The picture with a SYNC on G (Green) signal may vibrate.

Specification of RGB signals in each computer mode of the projector

By pressing the "NATIVE" button of the remote control, it will switch to the screen displaying the picture as its original size (real screen display). In the real screen display, pictures will be black-framed when picture resolution is lower than 1,024 × 768.

Any part of the picture will not be affected, if the picture resolution is higher than 1,024 × 768.

Pressing the EXPAND/PinP button on the control panel also switches to the real screen display. Keep holding the EXPAND/PinP button until the real screen display appears.

Important:

- Some computers may not be compatible with the projector.
- The projector's maximum resolution is 1,024 × 768. pixel. It may not be displayed correctly for the pictures of higher resolutions than 1,024 × 768.
- For the signals of the other format than the above, please make setting in the preset menu. (See page 32.)

Order of turning on / off

Turn on equipment in the following order to avoid trouble.

1. PC monitor
2. AV equipment
3. Projector
4. Personal computer

Turn off the equipment in the reverse order.

Important:

Some computers may not be compatible with this projector.

Cables and adapters

To connect personal computers to this projector, the following cables and adapters are necessary. The overview might be different from the picture below.

RGB cables (mini D-SUB 15P plug)

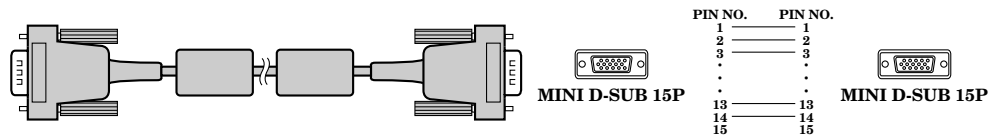

Note: The pins numbered 5, 9, 12 and 15 are not connected.

RGB Conversion adapter for MAC (mini D-SUB 15P jack - mini D-SUB 15P plug)



Note: Set the dip switch to the appropriate position.

Display mode	Resolution	Dip switch									
		1	2	3	4	5	6	7	8	9	10
13 inch	640 × 480	ON	OFF	OFF	ON	OFF	ON	ON	OFF	OFF	OFF
16 inch	832 × 624	ON	OFF	ON	OFF	OFF	ON	ON	OFF	OFF	OFF
19 inch	1024 × 768	ON	ON	OFF	OFF	OFF	ON	ON	OFF	OFF	OFF
21 inch	1152 × 870	ON	ON	ON	ON	OFF	ON	ON	OFF	OFF	OFF

RGB Conversion adapter for NEC PC (Option)

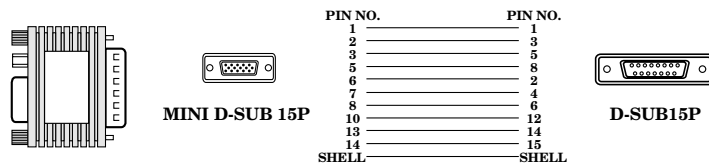

Basic connections (continue)

Projector + IBM PC or IBM PC compatibles (DOS)

Make sure that your equipment is turned off before connection.

Important:

- Connectors or analog RGB output adapters may be necessary depending on the personal computer connected to this projector. Please contact your dealer.
- The audio input for a personal computer is the stereo mini-jack. There are some personal computers that have different types of audio outputs or none at all. Please ask your dealer for details.
- For connection details, refer to the owner's guide of each component.

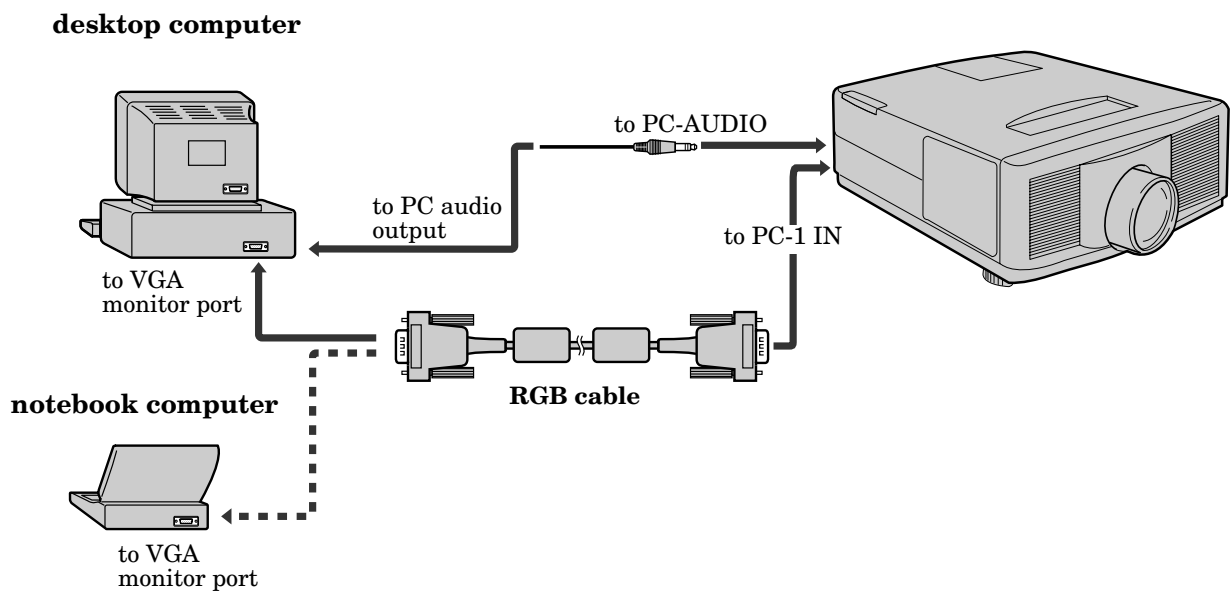

When outputting to both a PC monitor and the projector

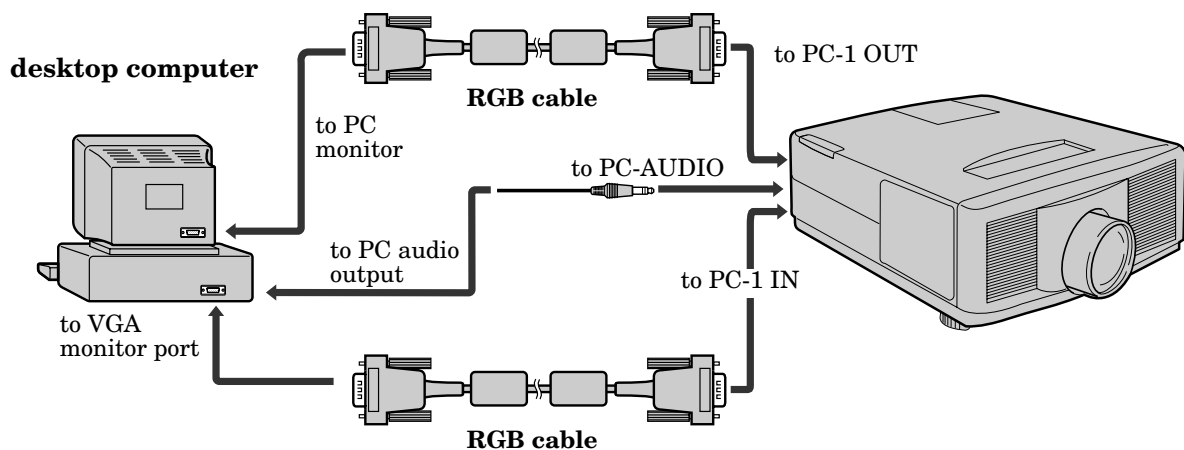

Projector + Macintosh

Make sure that your equipment is turned off before connection.

Important:

- A monitor output adapter is necessary for a Macintosh if it has no video port. Contact your dealer.
- If you use the RGB conversion adapter provided, set the dip switch to the appropriate position. See page 17.
- Connectors or analog RGB output adapters may be necessary depending on the personal computer connected to this projector. Please contact your dealer.
- The audio input for a personal computer is the stereo mini jack. There are some personal computers that have different types of audio outputs or none at all. Please ask your dealer for details.
- For connection details, refer to the owner's guide for each component.
- When outputting to both a PC monitor and the projector, use an Apple Macintosh monitor or multiscan monitor corresponding to Composite Sync.

desktop computer

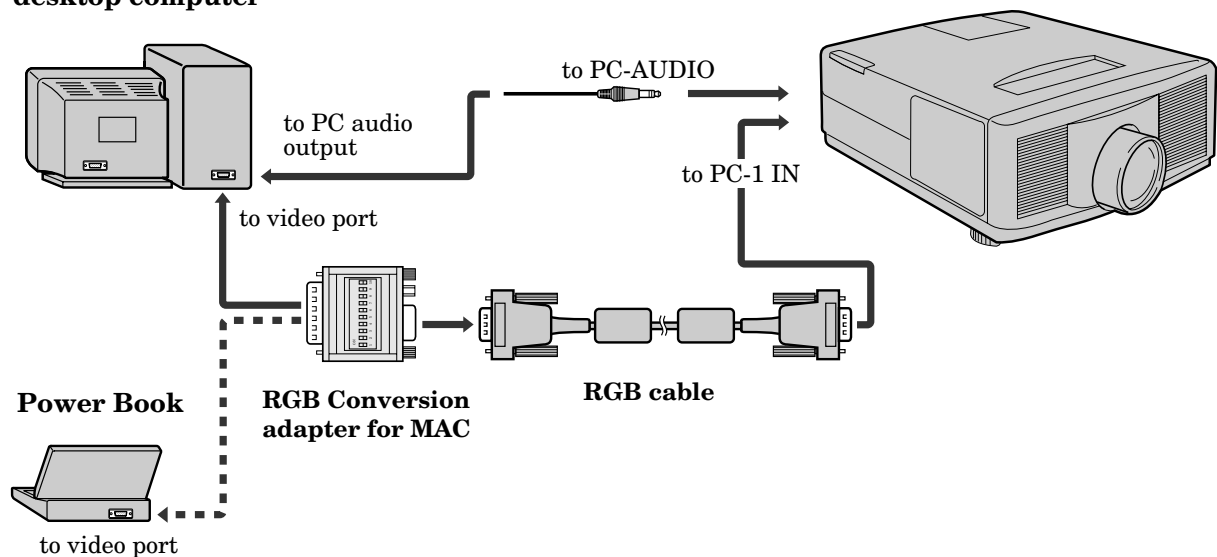

When outputting to both a PC monitor and the projector

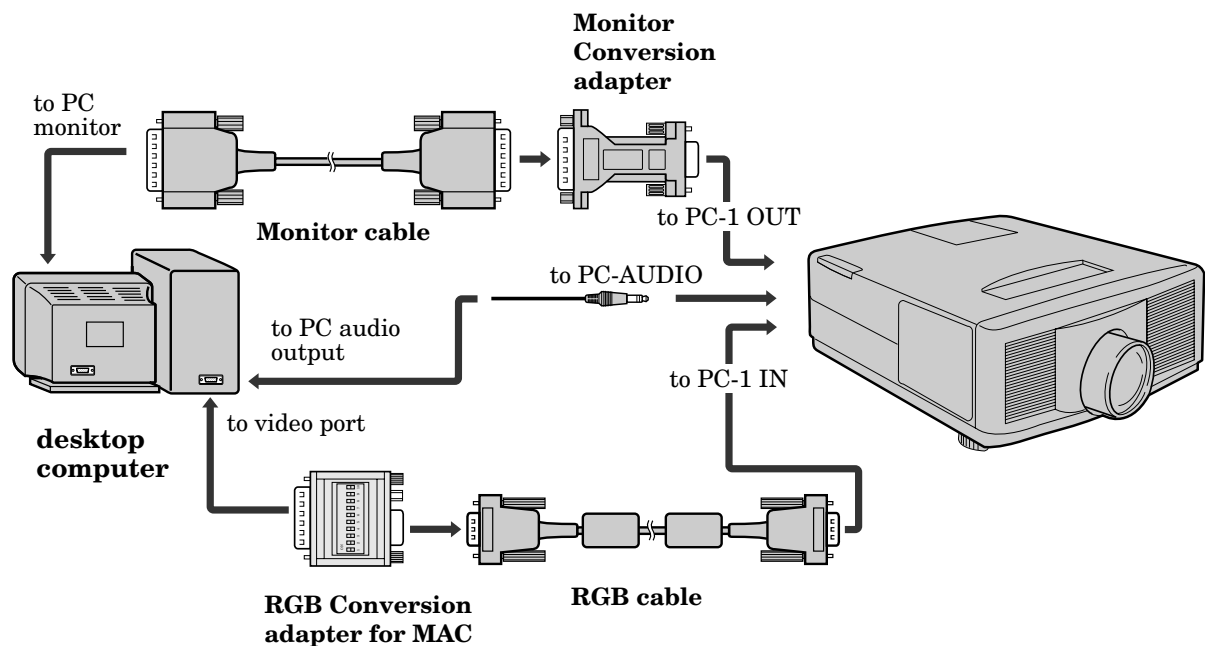

Basic connections (continue)

Projector + NEC PC-98 and EPSON PC series

Make sure that your equipment is turned off before connection.

Important:

- Connectors or analog RGB output adapters may be necessary depending on the personal computer connected to this projector. Please contact your dealer.
- The audio input for a personal computer is the stereo mini jack. There are some personal computers that have different type or no audio outputs. Please ask your dealer for details.
- For connection details, refer to the owner's guide of each component.

desktop computer

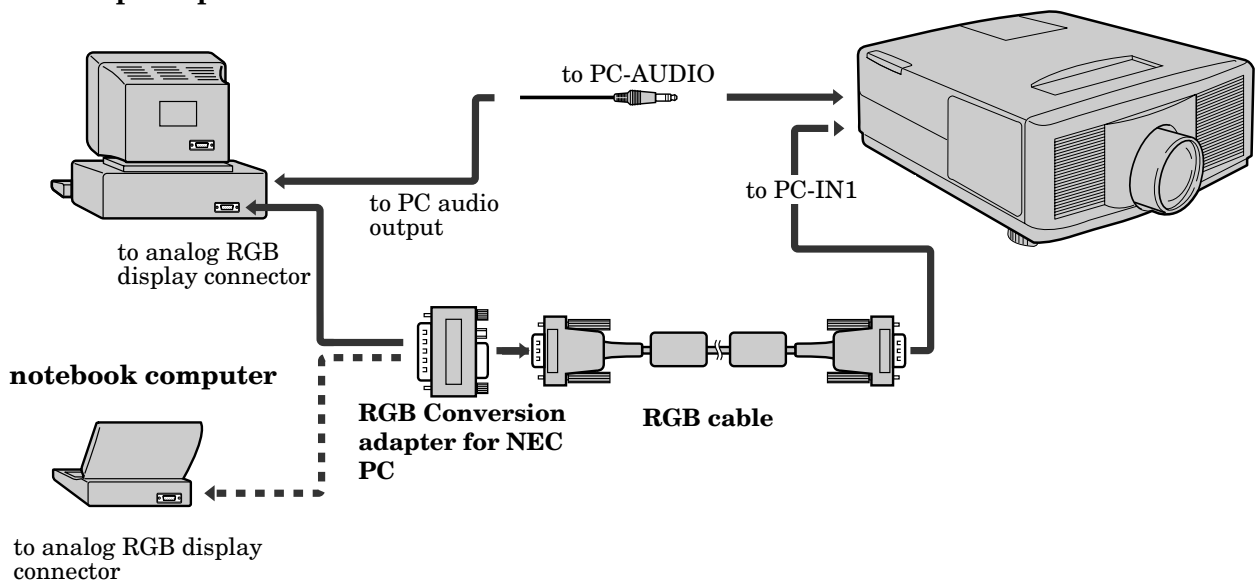

When outputting to both a PC monitor and the projector

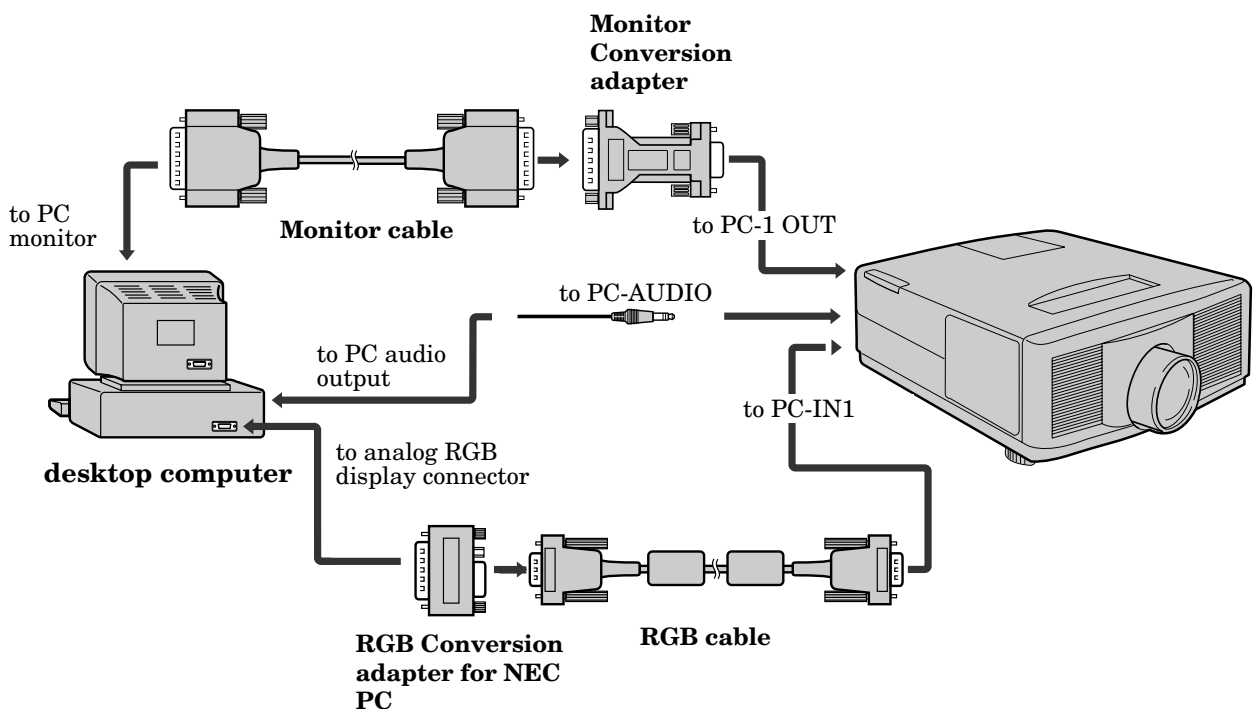

Projector + AV equipment

Make sure that your equipment is turned off before connection.

Important:

S-video signals take priority over video signals. If you input both S-video signals and normal video signals at the same time, the normal video input automatically shuts off.

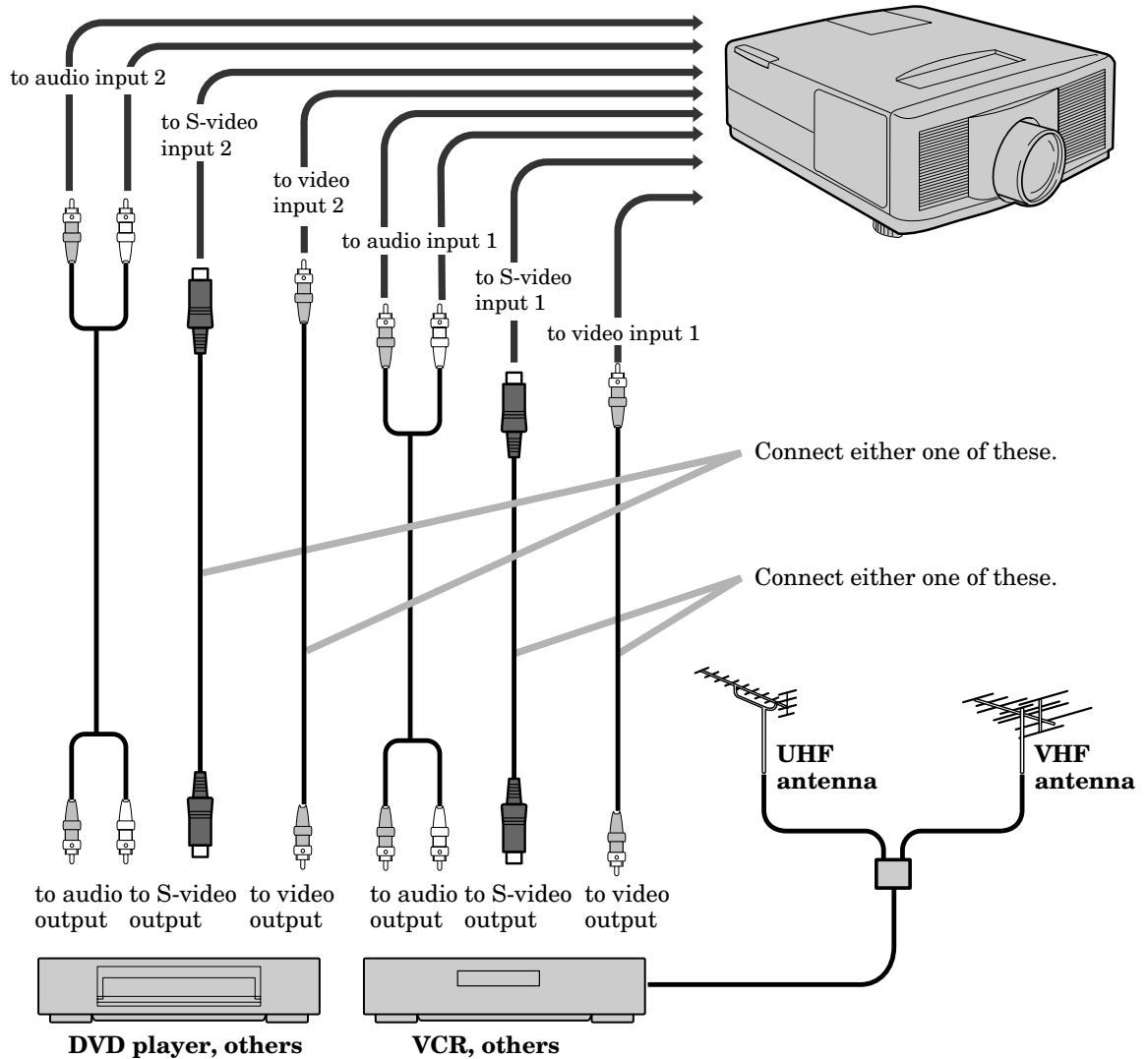

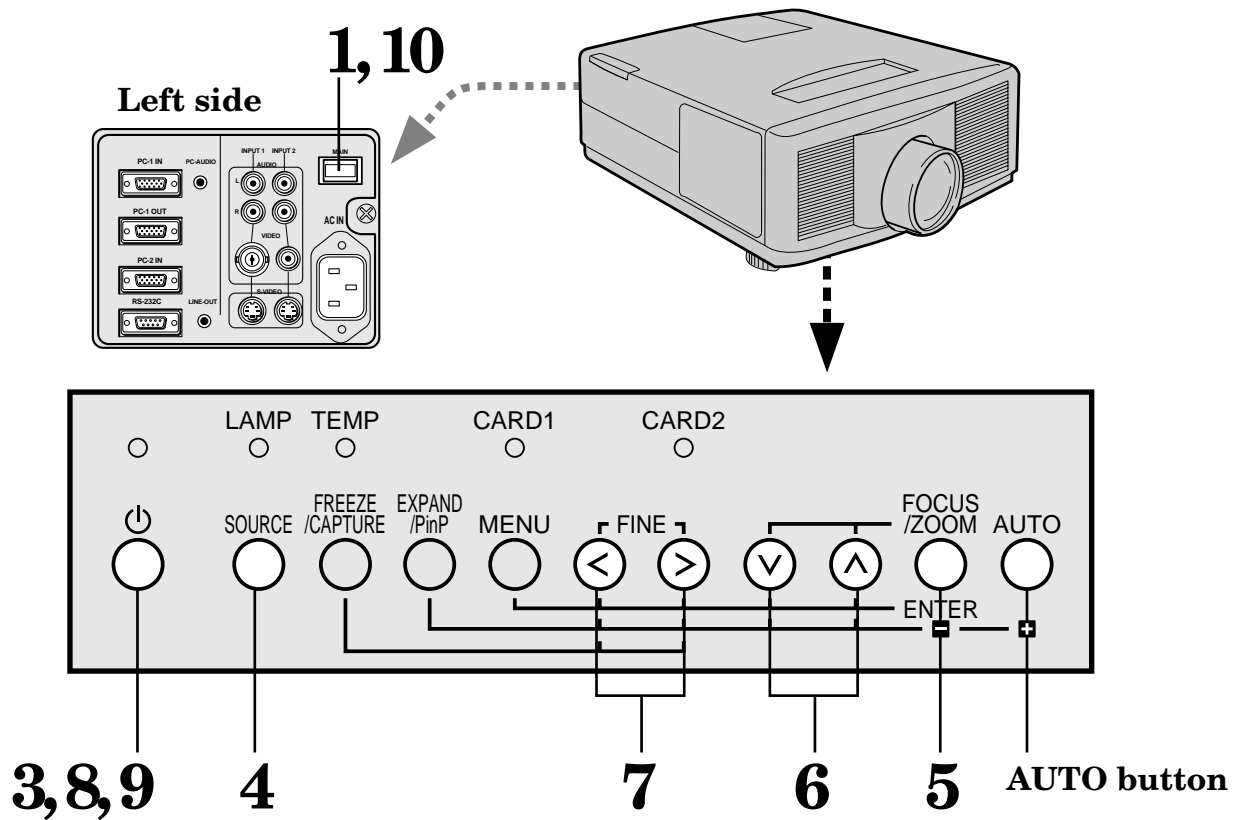

To operate projector power ON

Numbers 1~10 correspond to the instruction numbers below.



1. Put the projector into standby mode by pressing the main power switch. The POWER indicator lights up red.
2. Turn on the equipment connected to the projector.
3. Turn the projector on by pressing the POWER button. The light source lamp starts warming up, eventually turn on.

	indicator		LAMP	POWER
	condition			
	stand-by	-	-	red
	when light source lamp is on	green	green	green
	when light source lamp does not light up	-	-	red

Important:

- A darkened image may be seen right after pressing the POWER button due to warming up of this projector. When warming up, no other commands can be accepted.
- When the lamp indicator is blinking red, the service life of the lamp is about to end. Replace the lamp. See page 48.
- The picture might not be of optimum performance in extreme hot or cold conditions. (The projector is not malfunctioning.)

4. Select the desired external input source by using the SOURCE button.
The source changes in the sequence shown below:



- The projector automatically selects the appropriate signal system. When the source is selected to RGB1 or RGB2 and the image is not in the right place, set to display as blightest signal as possible, then press the AUTO button. If the image is still not in the right place, refer to USER PRESETS on page 32.
 - The projector automatically convert the image into full screen size. By pressing the NATIVE button, the native size image will appear.
5. Press the FOCUS/ZOOM button to FOCUS. “FOCUS” will appear on the display.
 6. Adjust with the \wedge or \vee buttons on the control panel (or \blacktriangle or \blacktriangledown buttons on the remote control) to get a fine picture.
 7. Adjust with the FINE \langle or \rangle buttons on the control panel (or \blacktriangleleft or \blacktriangleright buttons on the remote control) to get a clear picture.
- Focus and zoom adjustment by using the buttons on the control panel or the remote control is possible in the normal picture mode only. In PinP, EXPAND or cursor operation mode, the adjustment is impossible.

Turning off the projector

8. Press the POWER button.
The message “POWER OFF? YES : PRESS AGAIN” appears on the screen.
 - To exit from this mode, press any button except POWER button.
9. Press the POWER button again.
The light source lamp will be turned off.
By pressing the POWER button again, shuts off the light source lamp, but the exhaust fan continues to operate for 120 seconds to cool down the light source lamp and LCD panels.
10. Turn off the main power switch. When turning off the main switch, the POWER indicator turns off.

Caution:

- When you have finished using this equipment, wait 120 seconds for the exhaust fans to stop. Then turn off the main switch and unplug the power cable from the wall outlet, for safety purposes.
- After the lamp is turned off, the lamp cannot be switched on again for 60 seconds as a precautionary measure. It will take another 60 seconds before the lamp indicator goes off. If you wish to turn on the projector again, wait until the indicator is off then press the POWER button.
- Focus or zoom adjustment by the projector or the remote control is possible in the normal picture mode only. It is not possible to adjust when menu, PinP, zooming picture and cursor operation are activated.

The projector automatically shuts off when the lamp is used up in about 1,300 hours and not used until lamp replacement.

Menu operation

Several settings can be adjusted using Menu. There are 5 modes. You can also make adjustments using PCGC (personal computer graphic controller). See pages 42 ~ 44 for details.

MENU layers

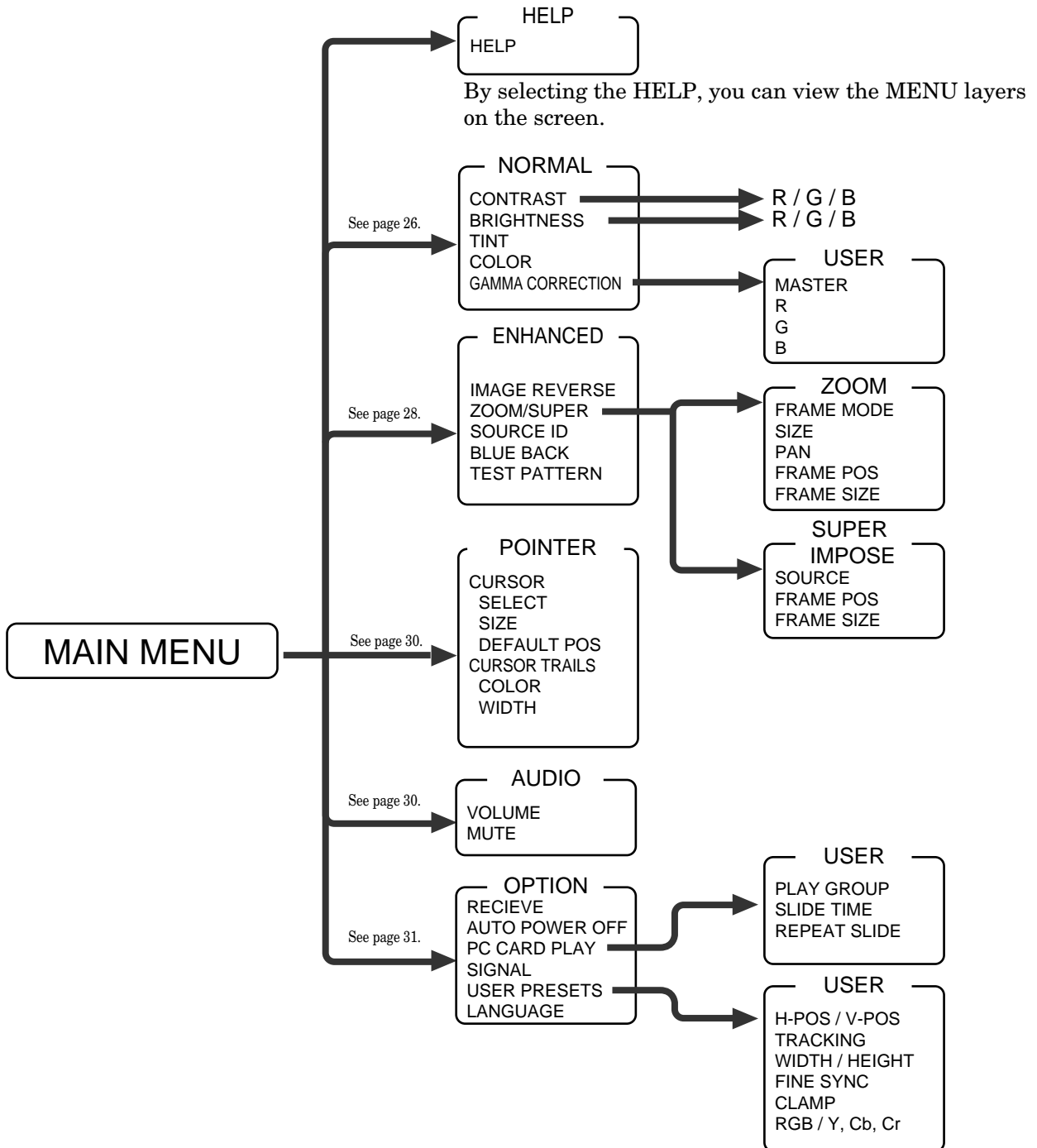

- If the menu operation is not working, simultaneously press the MENU and POWER button.

Basic operation

EXAMPLE: Brightness adjustment

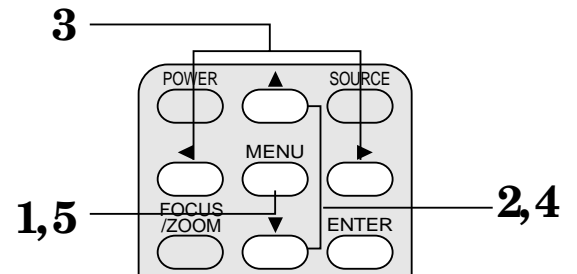
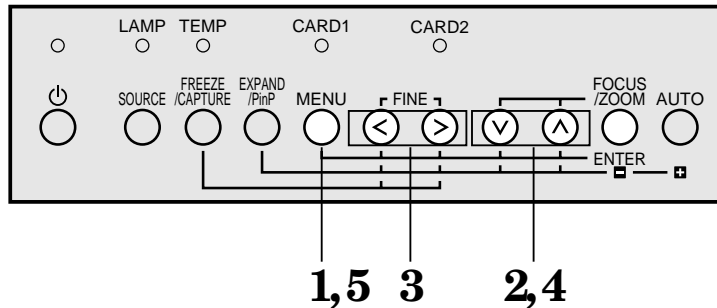

1. Press the MENU button once to display the on-screen menu.

HELP	CONTRAST	BRIGHTNESS	TINT	COLOR	GAMMA CORRECTION
	0	0	0	0	
NORMAL	R/G/B ▶	R/G/B ▶			USER ▶
ENHANCED					
POINTER					
AUDIO					
OPTION					
◀QUIT					RESET ▶

2. Press the \wedge or \vee buttons on the control panel (or \blacktriangle or \blacktriangledown buttons on the remote control unit) to select NORMAL.

HELP	CONTRAST	BRIGHTNESS
	0	0
NORMAL	R/G/B ▶	R/G/B ▶
ENHANCED		
POINTER		
AUDIO		
OPTION		
◀QUIT		

3. Press the \leftarrow or \rightarrow buttons on the control panel (or \blacktriangleleft or \blacktriangleright buttons on the remote control unit) to select BRIGHTNESS.

HELP	CONTRAST	BRIGHTNESS
	0	0
NORMAL	R/G/B ▶	R/G/B ▶
ENHANCED		
POINTER		
AUDIO		
OPTION		
◀QUIT		

4. Press the \wedge or \vee buttons on the control panel (or \blacktriangle or \blacktriangledown buttons on the remote control unit) to adjust brightness.

HELP	CONTRAST	BRIGHTNESS
	0	-15
NORMAL	R/G/B ▶	R/G/B ▶
ENHANCED		
POINTER		
AUDIO		
OPTION		
◀QUIT		

5. Exit the menu system by pressing the MENU button or the ENTER button to QUIT.

- To switch back to the factory preset of each menu, select RESET and press the ENTER button.
- When selecting RESET, the buttons cannot be operated for 2 to 18 seconds.

Menu operation (continue)

NORMAL menu

The following adjustments to the projected image can be done in this menu.

HELP	CONTRAST	BRIGHTNESS	TINT	COLOR	GAMMA CORRECTION	
	0	0	0	0	USER ▶	
NORMAL	■ R / G / B ▶	■ R / G / B ▶	■	■		
ENHANCED	┆	┆	┆	┆		
POINTER	┆	┆	┆	┆		
AUDIO	┆	┆	┆	┆		
OPTION	┆	┆	┆	┆		
◀QUIT	■	■	■	■		RESET ▶

CONTRAST Adjusts the picture contrast. The contrast becomes higher as the number increases. If you wish to select the color, select R/G/B and press the ENTER button. (The R/G/B setting menu will be displayed.) To exit the R/G/B setting menu, select RETURN and press the ENTER button. To switch back to the default condition, select RESET and press the ENTER button.

CONTRAST	R	G	B	
	0	0	0	
	■	■	■	
	┆	┆	┆	
	┆	┆	┆	
	■	■	■	
◀RETURN				RESET ▶

BRIGHTNESS Adjusts image brightness. The image becomes brighter as the number increases. If you wish to select the color, select R / G / B and press the ENTER button. (The R / G / B setting menu will be displayed.) To exit the R/G/B setting menu, select RETURN and press the ENTER button. To switch back to the default condition, select RESET and press the ENTER button.

BRIGHTNESS	R	G	B	
	0	0	0	
	■	■	■	
	┆	┆	┆	
	┆	┆	┆	
	■	■	■	
◀RETURN				RESET ▶

TINT Adjusts the color intensity of the image (only when NTSC or 4.43 NTSC is selected).

COLOR Adjusts the color balance in the image. The color balance of the image shifts green as the number increases and shifts to purple as the number decreases (only when NTSC, PAL, SECAM or 4.43 NTSC is selected).

GAMMA CORECTION For GAMMA CORRECTION, see page 27.

- To switch back to the default condition of NORMAL, select RESET and press the ENTER button.
- When selecting RESET, the buttons cannot be operated for 2 to 18 seconds.

GAMMA CORRECTION menu

The proportion of the brightness of input signals to that of output signals can be corrected effectively by adjusting GAMMA.

1. Select GAMMA CORRECTION of NORMAL menu and then press the ENTER button. (The GAMMA CORRECTION menu appears on-screen display.)

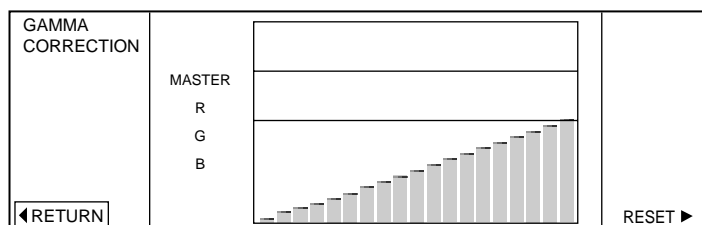

Horizontal axis: brightness of the input signals
 Vertical axis: brightness of the output signals
 Inclination: GAMMA

2. Press the \wedge or \vee buttons on the control panel (or \blacktriangle or \blacktriangledown buttons on the remote control) to select MASTER.

3. Press the \lt or \gt buttons on the control panel (or \blacktriangleleft or \blacktriangleright buttons on the remote control) to select the points brightness of the input signals.

4. Press the \wedge or \vee buttons on the control panel (or \blacktriangle or \blacktriangledown buttons on the remote control) to adjust the brightness of the output signals.

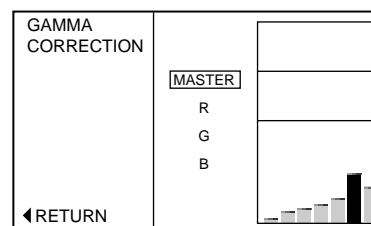

5. Repeat steps 3 and 4 for another point setting.

6. Press the ENTER button.

If you wish to change the color balance, follow the steps below.

7. Press the \wedge or \vee buttons on the control panel (or \blacktriangle or \blacktriangledown buttons on the remote control) to select the desired color R, G or B.

8. Press the \lt or \gt buttons on the control panel (or \blacktriangleleft or \blacktriangleright buttons on the remote control) to select the points brightness of the input signals.

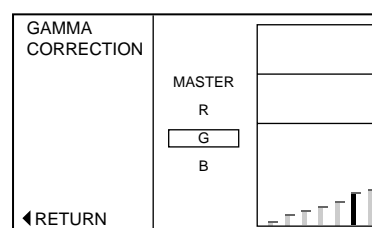

9. Press the \wedge or \vee buttons on the control panel (or \blacktriangle or \blacktriangledown buttons on the remote control) to adjust the brightness of the output signals.

10. Repeat steps 3 and 4 for another point setting.

11. Press the ENTER button.

12. Exit the menu system by pressing the MENU button.

- To switch back to the default condition of GAMMA CORRECTION, select RESET and press the ENTER button when the GAMMA CORRECTION display appears.
- When selecting RESET, the buttons cannot be operated for 2 to 18 seconds.

Menu operation (continue)

ENHANCED menu

The following adjustments for enhanced items can be done in this menu.

HELP	IMAGE REVERSE	KEystone	ZOOM/SUPER	SOURCE ID	BLUE BACK	TEST PATTERN	
NORMAL	OFF	0° <input type="checkbox"/>	ZOOM	ON	ON	OFF	
ENHANCED	MIRROR	3° <input type="checkbox"/>		OFF	OFF	1	
POINTER		6° <input type="checkbox"/>	SUPER			2	
AUDIO	INVERT	9° <input type="checkbox"/>	IMPOSE			3	
OPTION		12° <input type="checkbox"/>				4	
◀QUIT	MIRROR INVERT	15° <input type="checkbox"/>				5	RESET

IMAGE REVERSE Use to reverse or invert the projected image. MIRROR is used for rear projection. INVERT is effective when the projector is ceiling-mounted.

KEYSTONE Adjusts keystone correction of the image. If the image becomes keystone distortion, select the approximate setting. For normal use, select 0°.

- Do not adjust keystone in the PinP mode.

ZOOM/SUPER Sets the detail settings for zoom or super impose. Select the desired items by pressing the or button on the control panel (or or button on the remote control) and press the ENTER button. The desired setting menu appears. (For more details for ZOOM and SUPER IMPOSE, refer to pages 34 and 35.)

ZOOM

ZOOM	FRAME MODE	SIZE	PAN	FRAME POS	FRAME SIZE	
	1		H-POS	1 <input type="checkbox"/>	1 <input type="checkbox"/>	
	2	0	V-POS	2 <input type="checkbox"/>	2 <input type="checkbox"/>	
	3			3 <input type="checkbox"/>	3 <input type="checkbox"/>	
◀RETURN				4 <input type="checkbox"/>		RESET

FRAME MODE Selects the desired type of zoom. Select the desired type, 1, 2 or 3 by pressing the or buttons on the control panel (or or buttons on the remote control) and press the ENTER button.

Type 1 : Main image = normal picture , Sub image = zooming picture

Type 2 : Main image = zooming picture , Sub image = normal picture

Type 3 : Main image = zooming picture , Sub image = not appears.

SIZE Adjusts zooming magnification. The selectable values are 1.0 - 5.0.

- The magnification for zooming is actually the magnification of the vertical or horizontal direction, not the area.
- The selectable value may change according to other settings.

PAN









V-POS Use to make vertical adjustments to the position of the sub-image. The sub-image moves down as the number increases.

H-POS Use to make horizontal adjustments to the position of the sub-image. The sub-image moves to the right as the number increases.

FRAME POS Selects the desired position of the sub-image. Select the desired position by pressing the or buttons on the control panel (or or buttons on the remote control).

FRAME SIZE Selects the desired size of the sub-image. Select small, medium or large by pressing the or buttons on the control panel (or or buttons on the remote control).

**SUPER
IMPOSE**
(Picture in
Picture)

SUPER IMPOSE	SOURCE	FRAME POS	FRAME SIZE	
◀ RETURN	VIDEO1	1 	1 	RESET ▶
	VIDEO2	2 	2 	
	RGB1	3 	3 	
	RGB2	4 		
	PC1	5 		
	PC2			

SOURCE Selects the desired input source of the sub-image. Select the desired input source by pressing the \wedge or \vee buttons on the control panel (or \blacktriangle or \blacktriangledown buttons on the remote control).

FRAME POS Selects the desired position of the sub-image. Select the desired position by pressing the \wedge or \vee buttons on the control panel (or \blacktriangle or \blacktriangledown buttons on the remote control).

FRAME SIZE Selects the desired size of the sub-image. Select the desired size: small, middle or large by pressing the \wedge or \vee buttons on the control panel (or \blacktriangle or \blacktriangledown buttons on the remote control). Selecting No. 5 of FRAME POS doesn't change the frame size.

SOURCE ID Use to set SOURCE ID on or off. If you select OFF, the mode display automatically disappears after about four seconds. If you select ON, the mode display continues to appear. The SOURCE ID is automatically set to OFF, when the power is turned off.

BLUE BACK (VIDEO MUTE) Use to set BLUE BACK on or off. When there is no input signal, the projector displays a blue screen. Select OFF if you don't want to display a blue background.

TEST PATTERN Use to display the built-in test pattern on the screen. There are five different patterns. Select the desired pattern by pressing the \wedge or \vee buttons on the control panel (or \blacktriangle or \blacktriangledown buttons on the remote control).

Important:

To make the test pattern disappeared, press the buttons except FOCUS/ZOOM, + or - buttons while the MENU display is not on screen.

Menu operation (continue)

POINTER menu

The following adjustments to the cursor and cursor trails can be done in this menu.

HELP	CURSOR			CURSOR TRAILS		RESET ▶
	SELECT	SIZE	DEFAULT POS	COLOR	WIDTH	
NORMAL	1 ↘	1 ↘	H-POS	1 —	1 —	
ENHANCED	2 ↘	2 ↘	▲	2 —	2 —	
POINTER	3 ↘	3 ↘	V-POS	3 —	3 —	
AUDIO	4 ↘		50	4 —	4 —	
OPTION	5 ↘		▲	5 —	5 —	
◀QUIT			50	6 —	6 —	
			▼	7 —	7 —	

CURSOR

SELECT Selects the desired color of the cursor. Select the desired color by pressing the ^ or v buttons on the control panel (or ▲ or ▼ buttons on the remote control).

SIZE Selects the desired size of the cursor. Select the desired shape by pressing the ^ or v buttons on the control panel (or ▲ or ▼ buttons on the remote control).

DEFAULT POS

V-POS Use to make vertical adjustments to the position of the cursor. The cursor moves down as the number increases.

H-POS Use to make horizontal adjustments to the position of the cursor. The cursor moves to the right as the number increases.

CURSOR TRAILS

COLOR Selects the desired color for the cursor trail. Select the desired color by pressing the ^ or v buttons on the control panel (or ▲ or ▼ buttons on the remote control).

WIDTH Selects the desired width of the cursor trail. Select the desired width by pressing the ^ or v buttons on the control panel (or ▲ or ▼ buttons on the remote control).

AUDIO menu

HELP	VOLUME	MUTE	RESET ▶	
NORMAL	30	ON		
ENHANCED	⏮	OFF		
POINTER				
AUDIO				
OPTION				
◀QUIT	⏭			

AUDIO Adjusts the volume of sound. The volume becomes louder as the number increases.

MUTE Use to set MUTE on or off. Select ON to switch off the sound. Select OFF to switch the sound back on.

OPTION menu

The following adjustments to optional items can be done in this menu.

HELP	RECEIVE	AUTO POWER OFF	PC CARD PLAY	SIGNAL	USER PRESETS	LANGUAGE	
	FRONT	▲ USER — 30 ▼	MANUAL AUTO	AUTO NTSC PAL SECAM 4.43NTSC	USER ►	English Español Deutsche Français Italiano 中文	
NORMAL							
ENHANCED POINTER AUDIO OPTION		NO	USER ►				
◀QUIT	REAR						RESET ►

RECEIVE Select either **FRONT** or **REAR** to receive the infrared signal from the remote control.

AUTO POWER OFF Use to select the length of time before the projector switches to standby when there is no input signal selected source. Select **OFF** to cancel this function.

PC CARD PLAY Select either **MANUAL** or **AUTO** mode to play back the PC CARD. If you select **MANUAL**, the PC CARD will be played back according to the key operation. If you select **AUTO**, the PC CARD will be played back according to the **USER** setting. If you select **USER** and press the **ENTER** button, the user setting menu appears.

USER

PC CARD PLAY	PLAY GROUP	SLIDE TIME	REPEAT SLIDE		
	SLOT 1 SLOT 2	DEFAULT USER	ON OFF		
	GRP1 GRP2	▲ 1.0 min ▼			
◀RETURN					RESET ►

PLAY GROUP Selects the desired group to play back the PC CARD. Select the desired slot (**SLOT1** or **SLOT2**) by pressing the **^** or **v** buttons on the control panel (or **▲** or **▼** buttons on the remote control) and press the **>** button on the control panel (or **►** button on the remote control). Select the desired group by pressing the **^** or **v** buttons on the control panel (or **▲** or **▼** buttons on the remote control).

SLIDE TIME Use to select the length of time before the image switches to the next image when PC CARD PLAY is set to **AUTO**. Select **DEFAULT** to set the time to 1.0 min. If you wish another time, select **USER**, then select the desired time by pressing the **^** or **v** buttons on the control panel (or **▲** or **▼** buttons on the remote control).

REPEAT SLIDE Select **ON** to repeatedly play back the PC CARD presentation repeatedly. If you select **OFF**, the PC CARD will not be played back repeatedly.

Select **RETURN** and press the **ENTER** button to return to PC CARD PLAY menu.

SIGNAL When **AUTO** is set, the appropriate video standard is automatically selected according to the input signal. If the image does not appear correctly, select the desired video standard manually.

USER PRESETS For **USER PRESETS**, see page 32.

LANGUAGE Selects the desired language of the menu. Select the desired language by pressing the **^** or **v** buttons on the control panel (or **▲** or **▼** buttons on the remote control).

Menu operation (continue)

USER PRESETS menu

If you select USER and press the ENTER button, the user setting menu appear.

HELP	USER PRESETS	H-POS / V-POS	TRACKING	WIDTH / HEIGHT	FINE SYNC	CLAMP	RGB / Y,Cb,Cr	
NORMAL		H-POS		WIDTH				
ENHANCE		V-POS		HEIGHT			RGB	MEMORY
POINTER		0	0	0	0	0	Y,Cb,Cr	▶
AUDIO		0		0				
OPTION		0		0				
◀QUIT	◀RETURN							

H-POS Use to adjust the horizontal position of the image. The image moves to the right as the number increases.

V-POS Use to adjust the vertical position of the image. The image moves down as the number increases.

TRACKING Use to match the clock signals of the projector with the input signal to avoid image noise such as wide stripes.

HEIGHT Use to adjust the height of the image. The image size grows higher as the number increases. (Normally, there is no need for adjustments.)

WIDTH Use to adjust the width of the image. The image size grows wider as the number increases. (Normally, there is no need for adjustments.)

FINE SYNC Use to synchronize the projector with PC input signals so that the image is not blurred.

CLAMP Use to adjust the level of luminance. The projector does not need this adjustment for ordinary use. If you use a PC video card or something similar, the lighter colors of the projected image may become blurred. In this case, adjust CLAMP.

RGB / Y, Cb, Cr When the equipment (DVD player system, etc.) with Y, Cb, Cr connectors is connected to the PC-1 or PC-2 connector, select [Y, Cb, Cr]. Depending on the DVD player, the image may not be projected correctly with this projector.

The simple way of adjustment

1. Horizontal position:

Adjust the start position (the left end) using H-POS, and adjust the end position (the right end) using TRACKING. Then repeat these steps.

2. Vertical position:

Adjust the start position using V-POS.

- If you change the settings of the USER PRESETS, you must select MEMORY and press the ENTER button.
- The projector is able to memorize 2 signals setting. When reached over 2, settings of the signals will be deleted in chronologic order.
- By pressing the + button, you can change the setting among the default condition and memorized condition.

Advanced feature for presentation

Cursor operation

1. Press the CURSOR button.
The cursor appears on the screen.
 - The default position where the cursor appears on the screen can be set by using this on-screen menu.
2. Press the START/STOP button to ON.
The operation indicator will be illuminated.
(The operation indicator will turn off if the remote control is not used for a period of five minutes.)
3. Move the cursor by using the remote control.
Refer to page 13 for moving the cursor.
4. Press the START/STOP button to momentarily freeze the cursor movement. Press again to re-sume moving.
5. Press the CURSOR button to cause the cursor to disappear.

To draw a freehand line

1. Press the ICON button.
The pen, eraser, color of the cursor trails and the width of the cursor icons appear on the screen.
2. Select the pen icon, then press the SELECT button.
 - If necessary, change the color or width of the cursor trails by selecting the icon and pressing the SELECT button repeatedly.
3. Position the cursor where you want the path to begin.
4. Press and hold the SELECT button, moving the cursor to draw a path.

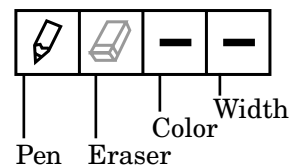

To draw square lines

1. Move the cursor to where you want the point of one corner of the square, and press the DOUBLE CLICK button. The cross mark appears.
2. Move the cursor to where you want the point of the opposite corner and press the DOUBLE CLICK button again.
3. For more square lines, repeat steps 1 and 2.
 - The cross mark will be disappeared by pressing the CANCEL button.

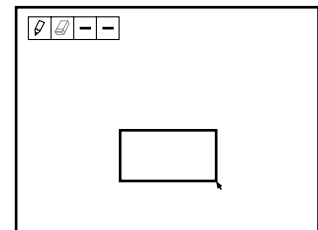
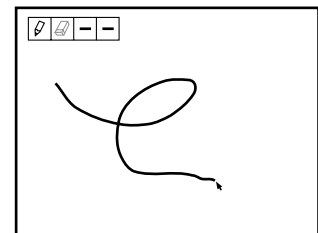

To erase lines

1. Press the ICON button.
The pen, eraser, color of the cursor trails and the width of the cursor icons appear on the screen.
2. Select the eraser icon, then press the SELECT button.
3. Press and hold the SELECT button, moving the cursor to erase lines.
 - By pressing the CURSOR, MENU, EXPAND, NATIVE or PinP buttons, the cursor trails will disappear.
 - You can also select the color and width of the cursor trails by using the on-screen menu.
 - When the MENU appears, the cursor will disappear.
 - When the cursor appears, the source ID will disappear.
 - You can not adjust the zoom/focus in the cursor operation mode.

Advanced feature for presentation (continued)

Expand

By pressing the EXPAND button on the remote control, you can view the detailed image of the picture.

1. Press the MENU button once to display the on-screen menu.
2. Press the \wedge or \vee buttons on the control panel (or \blacktriangle or \blacktriangledown buttons on the remote control) to select ENHANCED.
3. Press the \langle or \rangle buttons on the control panel (or \blacktriangleleft or \blacktriangleright on the remote control) to select PC ZOOM/SUPER.
4. Press the \wedge or \vee buttons on the control panel (or \blacktriangle or \blacktriangledown buttons on the remote control) to select ZOOM and then press the ENTER button.

ZOOM	FRAME MODE	SIZE	PAN	FRAME POS	FRAME SIZE
◀RETURN	1	▲ 0 ▼	H-POS ▲ 0 ▼ V-POS ▲ 0 ▼	1	1
	2			2	2
	3			3	3
					RESET ▶

5. Set the FRAME MODE, SIZE, PAN, FRAME POS and FRAME SIZE.
6. Press the \langle or \rangle buttons on the control panel (or \blacktriangleleft or \blacktriangleright buttons on the remote control) to select RETURN and then press the ENTER button.
7. Press the MENU button to exit the menu system.
8. Press the EXPAND button. Pressing the EXPAND button repeatedly will select on and off.

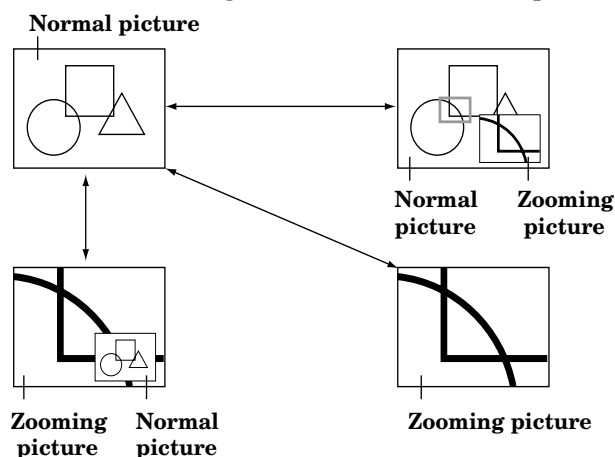

- You can magnify different areas of the active picture by pressing the \wedge , \vee , \langle or \rangle buttons on the control panel (or \blacktriangle , \blacktriangledown , \blacktriangleleft or \blacktriangleright buttons on the remote control). If you press and hold the \blacktriangle , \blacktriangledown , \blacktriangleleft or \blacktriangleright buttons on the remote control, the area is changed continuously.
- You can change the magnification of the zoomed area by pressing the + or - buttons. If you press and hold the + or - buttons on the remote control, the magnification is changed continuously.
- When the source is selected to VIDEO1, VIDEO2, PC1 or PC2, the expand function will not work.
- If you press the CURSOR button, the expanded area will disappear.
- In EXPAND mode, do not display the test pattern.
- In EXPAND mode you cannot adjust the zoom/focus.

Super impose (Picture in Picture)

One of the special features of this unit is the picture-in-picture (PinP) mode. PinP allows you to view different sources at the same time. The sub image will become a still picture.

1. Press the PinP button on the remote control. Pressing the PinP button repeatedly will select on and off.

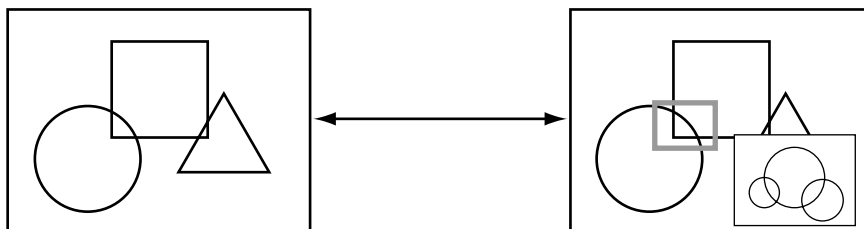

- In PinP mode, the sound will be switched off.
- When the main image is set to PC1 or PC2, the main and sub image will become still pictures.
- When the main image and sub image are set to RGB1, RGB2, VIDEO1 or VIDEO2, the sub image is recaptured by pressing the '-' button.
- When the sub image is set to PC1 or PC2, the sub image is not recaptured by pressing the '-' button.
- The sub image may vibrate. If this is the case, select the image again by pressing the '-' button.
- The super impose function won't work if there isn't an input signal.
- You can change the input source, the frame position and the frame size by using the on-screen menu.
- You can change the input source of the PinP image by pressing the '+' button.
- Pressing the ^ or v buttons on the control panel (or ▲ or ▼ buttons on the remote control), the main image will be in still mode and the sub image starts moving. Pressing the button again will resume display.
- In PinP mode you cannot adjust the zoom/focus.

PC-CARD

The projector can record one frame at a time and play back an image by using the PC-CARD. You can also play back the PC-CARD through the personal computer. See pages 39 - 41.

Using the PC-CARD

Use only the flash memory card of PCMCIA•ATA compatible type II.

- Due to PC-CARD type, some images can not be properly recorded.
- Before recording the images into the PC-CARD, prepare the group (GRP0) in the PC-CARD using the attached utility software PCV (PC-CARD viewer).

Setting up / replacing the PC-CARD

1. Set the projector into standby mode by pressing the main power switch. The POWER indicator lights up red.
2. Open PC-CARD cover on the left side of the projector.
3. To replace the card, press the eject button to take the card out.
4. Insert the card, making sure the direction of the card is correct. The PC CARD indicator will be illuminated.
5. Close the cover.

When the input source is set to PC1 or PC2, or during recording to the PC card, do not remove the PC card. The projector may not work correctly.

Emergency capture from projector source

1. Set the projector into standby mode by pressing the main power switch.
2. Turn on the equipment connected to the projector.
3. Insert the card
4. Turn the projector on by pressing the POWER button on the top control panel.
5. Select the desired external input source by using the SOURCE button.
6. Press the CAPTURE button, when the desired image is selected for recording. The image will freeze.
7. Press and hold the CAPTURE button for about three seconds before releasing. The projector displays a blue screen and a time gauge appears.
 - The recording takes about two minutes.
 - When the recording ends, the blue screen will disappear.
 - During recording, none of the buttons would operate.
 - During recording, do not push any buttons on the control panel, remote control, or PCGC.
 - When the image is not recorded correctly, the message "WRITE NG!" is appeared on the screen. In case the above happens, delete the incomplete file using the PCV software to obtain the memory storage capacity of the PC card.
 - To record one picture, the memory storage capacity of 2.4 MB is necessary. Please check for free space on the PCMCIA CARD before recording.
 - When there is not enough capacity left in PC-CARD, the message "WRITE NG!" will appear on the screen. In this case, turn the projector off and change PC-CARD.
 - The picture modified by keystone cannot be recorded correctly. Please set the KEYSTONE to 0° before recording.
 - We recommend to use the CAPTURE button on the remote control.
 - When using the CAPTURE button on the control panel, the projector may record repeatedly. In this case, press the < or > buttons on the control panel (or ◀ or ▶ buttons on the remote control) when the image is frozen. Then the unit will not record repeatedly.
8. To record another image, repeat steps 6 and 7.

Play back

1. Insert the prerecorded PC-card.

2. Press the MENU button once to display the on-screen menu.
3. Press the \wedge or \vee buttons on the control panel (or \blacktriangle or \blacktriangledown buttons on the remote control) to select OPTION.
4. Press the \langle or \rangle buttons on the control panel (or \blacktriangleleft or \blacktriangleright on the remote control) to select PC CARD PLAY.
5. Press the \wedge or \vee buttons on the control panel (or \blacktriangle or \blacktriangledown buttons on the remote control) to select MANUAL.
6. Press the MENU button to exit the menu system.
7. Press the SOURCE button repeatedly until PC-1 (or PC-2) appear on the screen.

The PC-CARD index display appears on the screen.

8. Press the \wedge , \vee , \langle or \rangle buttons on the control panel (or \blacktriangle , \blacktriangledown , \blacktriangleleft or \blacktriangleright buttons on the remote control) to select the desired image.
 - After pressing the FOCUS/ZOOM button, the \wedge or \vee buttons on the control panel (or \blacktriangle or \blacktriangledown buttons on the remote control) are worked for FOCUS or ZOOM adjustments. Pressing the other button, the buttons worked for image selection.
 - If the PC-CARD is recorded by using the personal computer, select the desired group by pressing the + or - button.
9. Press the \vee button on the control panel (or \blacktriangledown button on the remote control) to enter the image display mode.
10. Press the \langle or \rangle buttons on the control panel (or \blacktriangleleft or \blacktriangleright buttons on the remote control) to display another image.
11. Press the SOURCE button to quit the PC-CARD playback function.
 - After pressing the FOCUS/ZOOM button, the \wedge or \vee buttons on the top control panel (or \blacktriangle or \blacktriangledown buttons on the remote control) would work for FOCUS or ZOOM adjustments. When ZOOM or FOCUS disappears from the screen, the \wedge or \vee buttons wouldwork for image selection.

To automatically change the image, follow the steps as shown below.

1. Follow steps 1 to 4 from the previous instructions. (Select OPTION.)
2. Press the \wedge or \vee buttons on the control panel (or \blacktriangle or \blacktriangledown buttons on the remote control) to select USER and then press the ENTER button.
3. Set the PLAY GROUP, SLIDE TIME and REPEAT SLIDE. For more details of each items, see page 31.
4. Press the \langle or \rangle buttons on the control panel (or \blacktriangleleft or \blacktriangleright buttons on the remote control) to select RETURN and then press the ENTER button.
5. Press the \wedge or \vee buttons on the control panel (or \blacktriangle or \blacktriangledown buttons on the remote control) to select AUTO.
6. Press the MENU button to exit the menu system.
7. Press the SOURCE button repeatedly until PC-1 (or PC-2) appear on the screen. The selected image appears on the screen and the image automatically changes according your setting.
8. Press the SOURCE button to quit the PC-CARD playback function.

- **The projector is able to playback only the PC-CARD recorded by the projector or PCV.**
- When the \wedge , \vee , \langle or \rangle buttons on the control panel (or \blacktriangle , \blacktriangledown , \blacktriangleleft or \blacktriangleright buttons on the remote control) or +, -, PinP or NATIVE buttons are pressed, the AUTO PLAY function will be cancelled.
- During auto play, the CAPTURE, ENTER, AUTO or EXPAND buttons cannot be operated.
- During PC-CARD playback, the sound is switched off.
- PC-CARD of the following manufacturers has been confirmed of operation; EPSON, TDK, Logitec, Panasonic, Verbatim, I-O DATA

Advanced feature with PC

There are three types of application software provided.

1. PCV (PC Card Viewer)
2. PCGC (Personal Computer Graphic Controller)
3. SpacePointer (Driver for PC control by the remote controller)

Environment

The following system software and hardware are necessary to use the projector.

When you use Macintosh

PC	Macintosh series loading more than 68030 in CPU and a video card with which more than 256 colors are available
System software	7.1 or newer

Note: You cannot use the PCV with Macintosh.

When you use Microsoft® Windows®

PC	Microsoft® Windows® Operating System Version 3.1 or newer with the CPU loading more than 80386S and a display card with more than 256 colors are available
System software	Microsoft® Windows® operating system Version 3.1 and the system software that enables Windows® 3.1 to operate on your PC is needed.

EXPORT LAW ASSURANCES

You acknowledge and agree that the SOFTWARE is subject to restrictions and controls imposed by the United States Export Administration Act (the “Act”) and the regulations thereunder. You agree and certify that neither the SOFTWARE nor any direct product thereof is being or will be acquired, shipped, transferred or reexported, directly or indirectly, into any country prohibited by the Act and the regulations thereunder or will be used for any purpose prohibited by the same.

LIMITATIONS OF REMEDIES

Regardless of whether any remedy set forth herein fails of its essential purpose, in no event will Mitsubishi be liable to you for any special, consequential, indirect or similar damages, including any lost profits or lost data arising out of the use or inability to use the SOFTWARE or any data supplied therewith even if Mitsubishi or anyone else has been advised of the possibility of such damages, or for any claim by any other party.

Some states do not allow the limitation or exclusion of liability for incidental or consequential damages so the above limitation or exclusion may not apply to you.

In no case shall Mitsubishi’s liability exceed the price for the SOFTWARE.

A. PCV (PC Card Viewer)

PC-CARD viewer (PCV) is a utility software that lets you record and project an image to a PC-CARD by using a personal computer.

Installation of software

1. Start up Microsoft® Windows®.
2. Insert the floppy disk labeled "PROJECTOR DRIVER (5/5) PCV (PC Card Viewer)" in the projector floppy disc drive.

If you use the Microsoft® Windows® 95 Operating System or a more recent version

3. Start up Program Manager.
Click the [Start] button and select the [Run (R)] command. Then the [Run] dialog box is displayed. Move onto step 4.

If you use the Microsoft® Windows® Operating system Version 3.1 or a more recent version

3. Select the [Run (R)] command on the icon menu so that the dialog box [Run] is displayed.
4. If you inserted the floppy disk to drive A, type [A:\Setup] in the "command line" text box and click the "OK" button. The letter [A] may be different according to the drive you use.
5. When the setup program starts up, follow the on-screen instructions.
6. When the message "Finished" appears on screen, click the [OK] button to complete the installation.

Starting up PC Card Viewer

1. Insert the PC card to the PC Card slot on the personal computer.
2. Double click the [PCV] icon to start up the PC Card Viewer.

Command reference

The command references are as shown below:

File

New presentation...	Create a new presentation.
Open presentation...	Open an existing presentation.
Close presentation...	Close the active presentation.
Save presentation...	Save the active presentation from the selected PC-CARD drive.
Delete presentation...	Remove the active presentation from the selected PC-CARD drive.
Open image file...	Import an image from a Bitmap format file.
Exit	Quit the PC Card Viewer.

Edit

Cut	Remove the selected images of the active presentation and keep them available to paste elsewhere.
Copy	Copy selected images from the active presentation for pasting elsewhere.
Paste	Paste the last image cut or copied to the clipboard into your current presentation.

Tool

Capture...	Switch to the capture mode and open the capture dialog box.
Delete image...	Remove the selected image from the active presentation.

View

Tool Bar	Display or hide the tool bar from the window.
Status Bar	Display or hide the status bar from the window.

Option

Select card drive...	Select (or change) the PC-CARD drive.
Card drive Info...	Display the information of the selected PC-CARD drive.
Index image size...	Select the size of index image.

Help

About PCV...	Display the version of PCV.
--------------	-----------------------------

Advanced feature with PC (continued)

Recording the image

When you wish to record the image of the display to a PC-CARD.

1. In the PCV main window choose [Select card drive...] under the [Option] menu and then choose the PC-CARD drive.
2. Choose [New presentation...] under the [File] menu.
The new presentation window will open.
3. Choose [Capture...] under the [Tool] menu.
The PCV windows disappear and the capture dialog box appears.
4. Display the image you wish to record on the screen.
5. Click the capture button.
The Format setting window appears.
6. Select the Format, BMP or JPEG.
If you select JPEG, select the Quality.
You can confirm the compressed image by clicking the Preview button.
7. Click OK button.
8. Click the return button.
The presentation window will open. The recorded image appears on the presentation window.

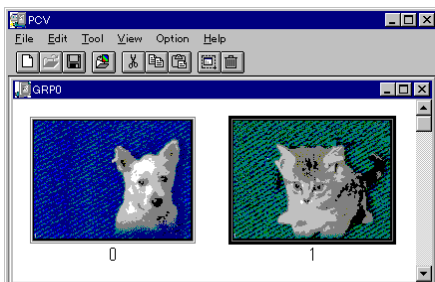
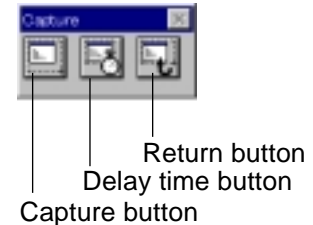

Depending on the personal computer, the recorded image can appear incorrectly. In this case, set the delay time longer by using the Delay time dialog box and repeat steps 5 to 7.



9. Repeat steps 4 to 8 for other images.
10. Choose [Save presentation...] under the [File] menu.
11. Choose [Exit] under the [File] menu to quit from PCV.

When you wish to record the image from existing files.

1. In the PCV main window choose [Select card drive...] under the [Option] menu and then choose the PC-CARD drive.
2. Choose [New presentation...] under the [File] menu.
The new presentation window will open.
3. Choose [Open image file...] under the [File] menu.
The list box displays the names of the files.
4. Select the image you wish to record.
5. Click OK button.
6. The recorded image appears on the presentation window.

- The maximum number of images that can be recorded to a PC card is 160.
- The maximum number for the group (presentation) is 99.
- JPEG file cannot access.

7. Repeat steps 4 to 6 for other images.
8. Choose [Save presentation...] under the [File] menu.
9. Choose [Exit] under the [File] menu to quit from PCV.

Editing the presentation

Delete the image

1. Select the image to be deleted.
2. Choose [Delete image...] under the [File] menu.

Sequencing

A. Exchange images

You can exchange the images among images next to each other.

1. Select an image to be exchanged.
2. Drag the image and drop on the next or previous image.

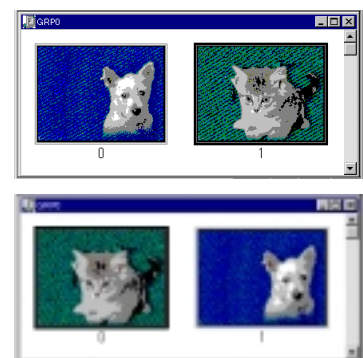

B. Move images

You can move images to another position.

1. Select an image to be moved.
2. Drag the image and drop it on the other image (except next or previous image).
The image will be moved to the previous position of the dropped image.

Move images to another presentation file

You can move images to another presentation file.

1. Select an image to be moved.
 2. Drag the image and drop on another presentation window.
The image will be moved to the last position of the dropped presentation.
- By using Cut, Copy & Paste, you can also edit the presentation.

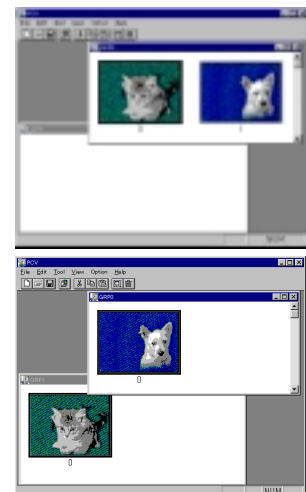

Preview an image

1. Select an image to be previewed.
2. Double click the image.
The preview image appears on the displays.

Display image information

1. Click the image by using the right button of the mouse.
The image information window appears.
2. Choose OK to close the image information window.



Advanced feature with PC (continued)

B. PCGC (Personal Computer Graphic Control)

By connecting to personal computer is RS-232C port, you can operate your computer with the projector remote control. Also you can set the menu setting of the projector by computer.

Connection

Control cable

- RS-232C cable (reverse)
- RS-232C adapter for Macintosh
- RS-232C adapter for NEC 98 series

Projector + IBM PC or IBM PC compatibles (DOS/V)

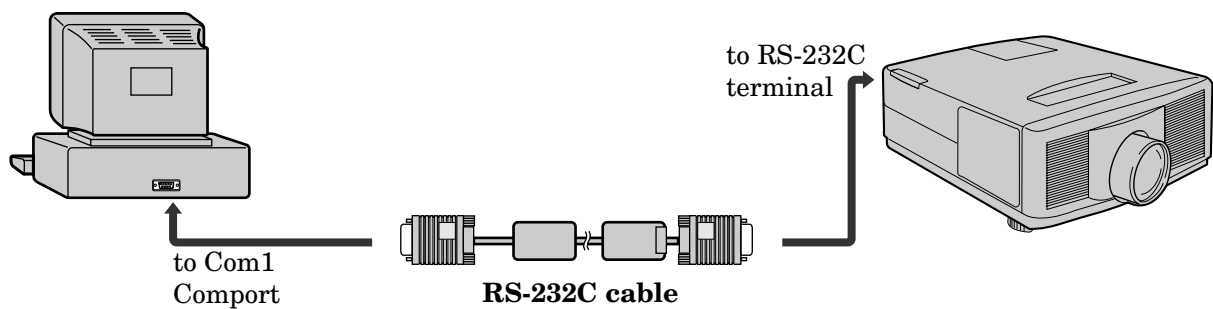

Note: If your PC (IBM or IBM compatible) is equipped only with a 25-pin serial port connector, a 25-pin serial port adapter is required. Contact your dealer for details.

Projector + Macintosh

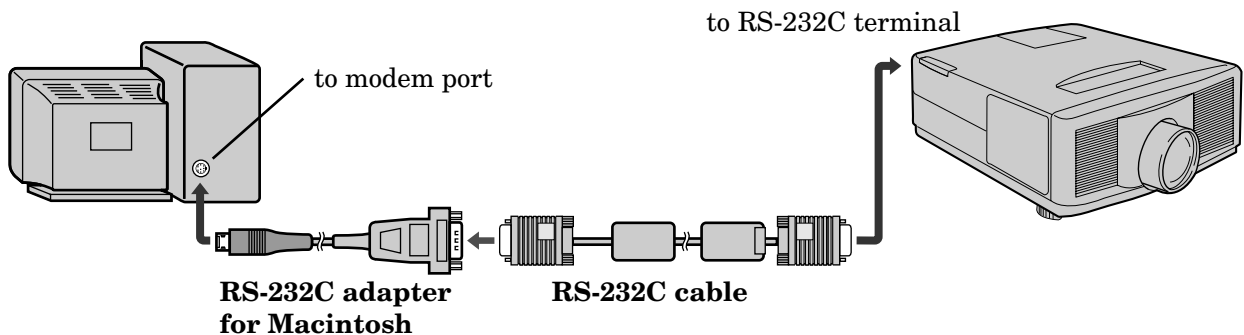

Note: If the only serial port is a "modem/printer", use it.

Projector + NEC PC 98 and EPSON series

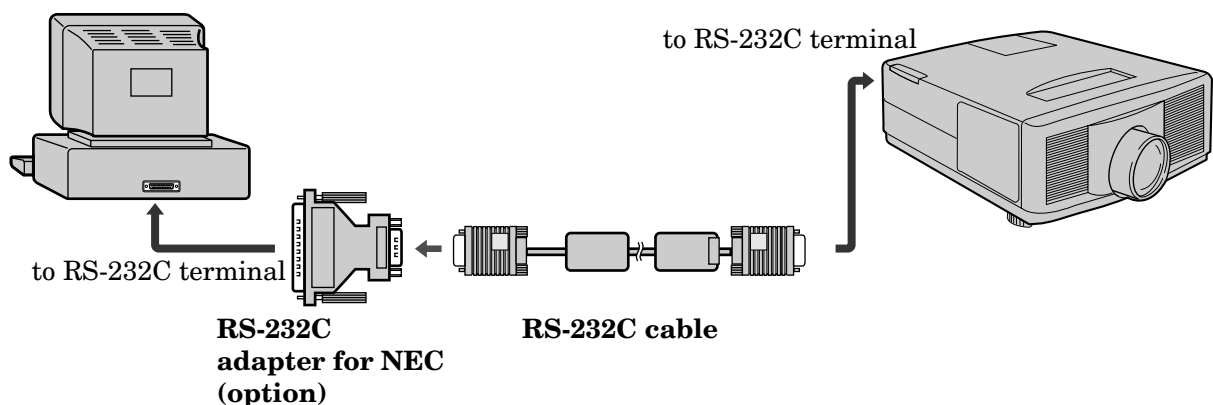

Installation of software

For Macintosh

1. Insert the floppy disk of "PROJECTOR DRIVER (2/5) PCGC (Mac)" to the floppy disk drive.
2. Copy "PCGC" folder to anywhere on the hard disk.

For Microsoft® Windows®

1. Start up Microsoft® Windows®.
2. Insert the floppy disk labeled "PROJECTOR DRIVER (1/5) PCGC (Win)" to the floppy disk drive.

If you use the Microsoft® Windows® 95 Operating System or a more recent version

3. Click the [Start] button and select the [Run (R)] command. Then the [Run] dialog box is displayed. Move onto step 4.

If you use the Microsoft® Windows® Operating system Version 3.1

3. Select the [Run (R)] command on the icon menu so that the dialog box [Run] dialog box is displayed.
4. If you insert the floppy disk to drive A, type [A:\Setup] in the "command line" text box and click the "OK" button. The letter [A] may be different according to the drive you use.
5. When the setup program starts up, follow the on-screen instructions.
6. When the message "Finished" appears on screen, click the [OK] button to complete the installation.

Starting up PCGC

Double click the [PCGC] icon in the setup folder to start up PCGC.

- Do not use SpacePointer during the PCGC operation.

A. Indicator and main menu control window

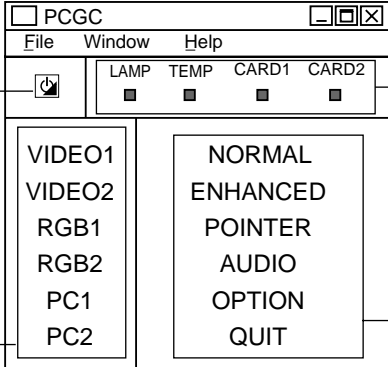

Power button and indicator
Use to turn the projector on or off when MAIN POWER is on. When in standby mode, this indicator lights up red. When the projector is fully "ON", the button lights up green.

Input selector
Click to select an input source. The input sources are; VIDEO1, VIDEO2, RGB1, RGB2, PC1 and PC2. You can only select PC1 or PC2 when the PC card is inserted in the projector.

Indicators
(Same as on the projector. See pages 8 and 9.)

- Each indicator may not match the one of those on the control panel.

Main MENU selector
Click to select sub menu. The sub menus are NORMAL, ENHANCED, POINTER, AUDIO and OPTION. To quit this software click QUIT.

Advanced feature with PC (continued)

B. Sub menu control window

The window is changed according to the selected position of the main menu selection.

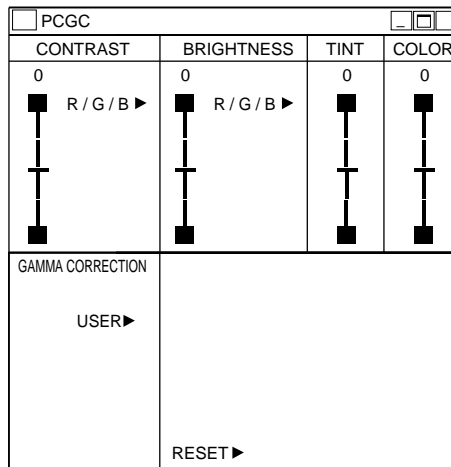

C. Remote control window

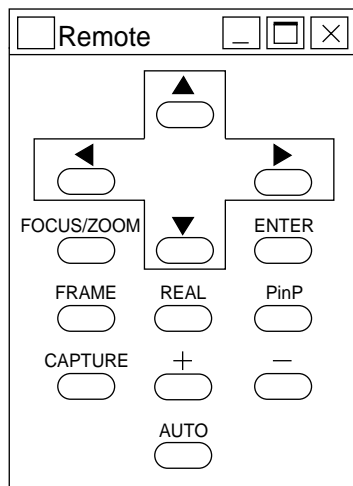

Note:

- When you operate the PCGC, do not use SpacePointer.
- Make sure proper connection have been made, or else the PCGC will not start up.
- When you operate the PCGC, switch off the menu display on the projector.
When you operate the PCGC, be sure not to press any buttons on the control panel on the projector (except the POWER button).

Caution:

- Mitsubishi is not responsible for any complications caused by the use of this PCGC software. For improvement, Mitsubishi Electric America reserves the right to change or alter any or all specification or design of this remote control and the content of the owner's guide without any prior notice.
- No part of this software and owner's guide may be reproduced, transmitted, transcribed, stored in a retrieval system, or translated into any language in any form by any means. Otherwise, this will be considered as a copyright infringement.

C. SpacePointer

The remote control provides remote PC operation for presentation from PC. (Space pointer)

Connection

The connection is the same as for PCGC. Refer to page 42.

Installation of software

For Macintosh

1. Insert the floppy disk of "PROJECTOR DRIVER (4/5) POINTER DRIVER (Mac)" to the floppy disk drive.
2. Copy "Space pointer" in the "US" folder to the system folder.
3. Restart the Macintosh.

For Microsoft® Windows®

1. Start up Microsoft® Windows®.
2. Insert the floppy disk labeled "PROJECTOR DRIVER (3/5) POINTER DRIVER (Win)" to the floppy disk drive.

If you use the Microsoft® Windows® 95 Operating System or a more recent version

3. Click the [Start] button and select the [Run (R)] command. Then the [Run] dialog box is displayed.
4. If you insert the floppy disk to drive A, type [A:\win95\Setup] in the "command line" text box and click the "OK" button. The letter [A] may be different according to the drive you use.
5. When the setup program starts up, follow the on-screen instructions.
6. When the message "Finished" appears on screen, click the [OK] button to complete the installation.

If you use the Microsoft® Windows® Operating system Version 3.1

3. Select the [Run (R)] command on the icon menu so that the dialog box [Run] is displayed.
4. If you insert the floppy disk to drive A, type [A:\win31\Install] in the "command line" text box and click the "OK" button. The letter [A] may be different according to the drive you use.
5. Select the [Installation (I)] command on the installation menu.
6. When the setup program starts up, follow the on-screen instructions.
7. When the message "Finished" appears on screen, click the [OK] button to complete the installation.

Operation of PC by remote control

The remote control provides remote PC operation for presentation from PC.

1. Press the SOURCE button to select RGB1 or RGB2.
2. Press the START/STOP button to ON.
The operation indicator will be illuminated.
3. Confirm that the cursor of the projector does not appear on the screen. If the cursor does appear, press the CURSOR button to OFF.
You can use the SELECT, CANCEL and DOUBLE CLICK button in the same way as the button on the mouse. You can also move the cursor of PC by using the remote control. For cursor moving, see page 13.
4. Press the START/STOP button to exit from PC control mode.

Advanced feature with PC (Continued)

Setting of SpacePointer

You can set the several settings in the Space Pointer control panel in the control panel folder.

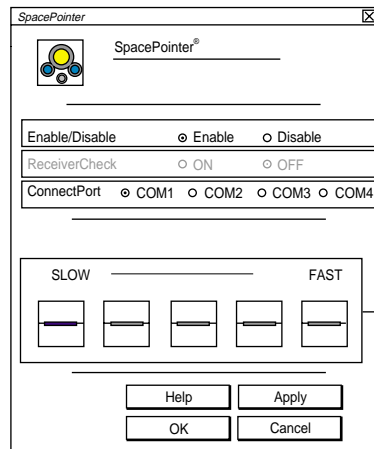

Enable/Disable

For normal use set to Enable. If you do not use SpacePointer, set to Disable.

Unselectable

Unselectable

Port selection

Used to select the port connected to the projector.

Tracking speed

If you click Fast, the cursor moves more than twice as fast as you move the space pointer. When you first try the remote control, set it to slow.

Uninstallation of software

For Macintosh

1. Move "Space pointer" in the control panel folder in the system folder to "Trash".
2. Restart the Macintosh.

For Microsoft® Windows®

1. Start up Microsoft® Windows®.
2. Insert the floppy disk labeled "PROJECTOR DRIVER (3/5) POINTER DRIVER (Win)" to the floppy disk drive.

If you use the Microsoft® Windows® 95 Operating System or a more recent version

3. Click the [Start] button and select the [Run (R)] command. Then the [Run] dialog box is displayed.
4. If you insert the floppy disk to drive A, type [A:\win95\Spuninst] in the "command line" text box and click the "OK" button. The letter [A] may be different according to the drive you use.
5. When the setup program starts up, follow the on-screen instructions.
6. When the message "Finished" appears on screen, click the [OK] button to complete the installation.

If you use the Microsoft® Windows® Operating system Version 3.1

3. Select the [Run (R)] command on the icon menu so that the dialog box [Run] is displayed.
4. If you insert the floppy disk to drive A, type [A:\win31\Install] in the "command line" text box and click the "OK" button. The letter [A] may be different according to the drive you use.
5. Select the [Uninstallation (U)] command on the installation menu.
6. When the setup program starts up, follow the on-screen instructions.
7. When the message "Finished" appears on screen, click the [OK] button to complete the installation.

Maintenance

Caution:

Be sure to turn off the projector and unplug the power cord from the wall outlet before you perform any maintenance on the projector.

Cleaning the air-filter

Clean the air-filter frequently. If the filter or ventilation slots become clogged with dirt or dust, the temperature inside of the projector may rise and shut off the power (the thermal indicator starts to blink red).

1. Press and raise the air-filter cover with a screwdriver (-).

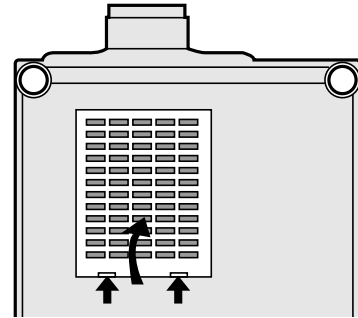

2. Wash the air-filter.
Use water or a mild detergent diluted with water to clean the filter. Rinse the filter thoroughly and let it dry completely. If the filter is damaged or becomes extremely dirty, contact your dealer for replacement information.

3. Attach the air filter to the cover.

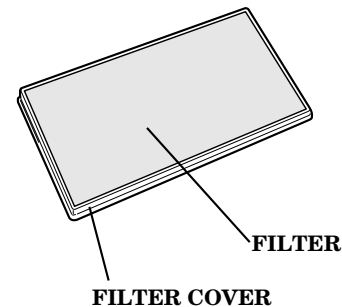

4. Reinstall the air-filter cover.

Note: The power will not turn on if the air-filter cover is improperly installed.

Caution:

Be sure to use the projector with an air-filter. If not, dust may get inside the projector, causing a fire or a breakdown.

Cleaning the projector and the ventilation slots

Use a soft cloth to clean the projector and the ventilation slots. When the slots become dirty, wipe them with a soft cloth dampened with a diluted mild detergent, and then wipe them with a dry cloth. To protect the surface of the projector from fading or deteriorating:

- Do not spray insecticide on or inside the projector.
- Do not use benzine or thinner to clean it.
- Do not let rubber or plastic materials come into contact with the projector.

Cleaning the lens

Use a standard lens-cleaning brush or a piece of lens tissue dampened with lens cleaning fluid. The lens surface is fragile. Use only recommended, nonabrasive lens-cleaning materials. Do not touch the lens with your fingers.

Replacement of a light source lamp

The light source lamp is designed to project the image on the LCD panel. When the light source lamp no longer functions, replace it with a new one to ensure optimum performance.

Caution:

- Do not remove the light source lamp from inside of this equipment immediately after using the projector, you may get burned because of the high temperature of the light source lamp.
- When you replace the light source lamp, press the power button to power off, then wait for 120 seconds in stand-by mode to cool down the lamp and LCD panels. Turn off the main switch, unplug the power cord from the outlet and wait one hour so that the lamp is cool to the touch.
- Do not remove the light source lamp except for replacement. Careless treatment can cause injury or fire.
- Do not touch the lamp directly. It may be broken and may cause you to injure or burn yourself.
- Be sure not to drop the lamp lid screw into the projector. Also be sure also not to insert metal or any flammable objects, it may cause fire or an electric shock. If any objects are inserted, please unplug and contact your dealer.
- Install the lamp securely, failure to do so it may cause a fire.

1. Loosen the screw of the lamp lid on the top cover using a screw driver(-) or a coin, and remove the lid.

Important:

Be careful not to damage the electric wire connected to this equipment.

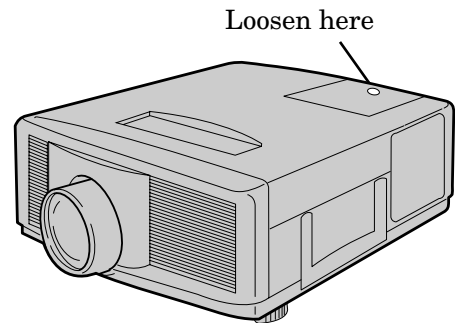

2. Use a screwdriver (+) to loosen the two lamp screws.
Use a soft cloth to cover the lamp.
3. Hold onto the projector by the handle as you pull out the lamp.

Caution:

For the lamp you have removed, do not spill liquid on it, place it near flammable objects or where children can touch it. Otherwise, it will cause injury or fire.

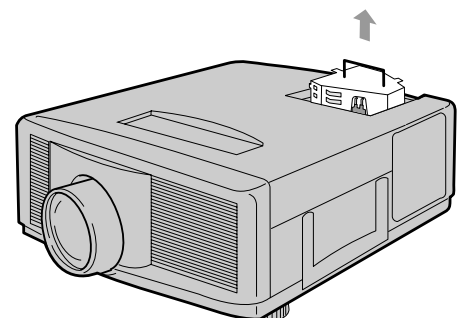
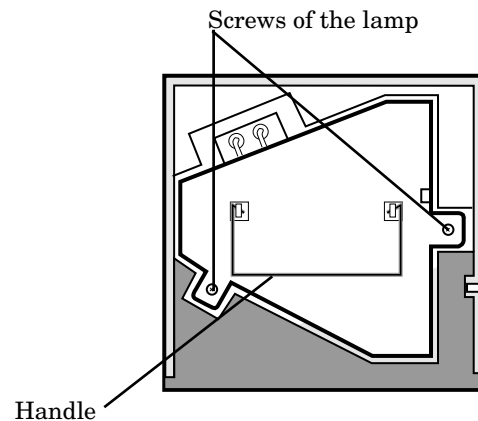

4. Hold onto the projector by the handle and insert it securely into the projector body.
 - Be sure that the projector guide is firmly inserted between the right and left lamp guides.
Do not touch the lamp directly, place a cloth over the replacement lamp.

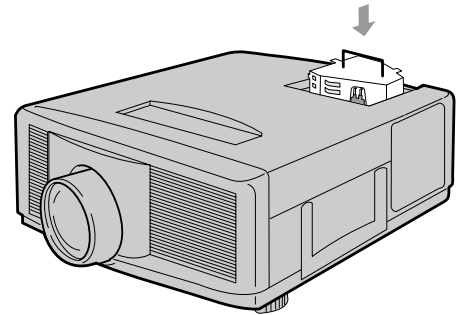

Important:

- Replace with same type lamp rated.
- Avoid squeezing the light sources lamp or getting finger prints on it. Mishandling the lamp can shorten the lamp life, cause it to burst during operation or reduce its illumination.

5. Tighten up the two screws of the lamp using a screwdriver (+).
6. Tighten up the screw of the lamp lid using a screwdriver (-) or a coin.

Important:

The projector will not turn on if you do not secure the lamp lid.

7. Plug in the power cord, switch on the projector and reset lamp time by pressing the <, > and POWER buttons simultaneously.

Purchase of the light source lamp

The expected life of the metal halide light source lamp is 1,300 hours. However, to maintain optimum performance, it is recommended that the light source lamp be replaced at 1,000 hour intervals. When the lamp no longer works well, replace it with a new one specified for this projector. Consult your dealer, for recommended replacement lamps.

The life of the lamp

The average life of the lamp for the projector is about 1,300 hours of consecutive use. The lamp indicator will blink in red after approximately 1,000 hours. When the lamp has been used for about 1,200 hours, the message “PLEASE CHANGE THE LAMP.” will appear on the screen. When the lamp has been used for about 1,300 hours, the projector will automatically shut off for the safety of the lamp and the power indicator light up in red. The projector cannot be used until the lamp has been replaced.

Caution:

- The light source lamp is fragile. Be careful not to cut yourself with the fragments.
- The lamp life depends on the environment. For replacement lamps, please contact your dealer.

The projector automatically shuts off when the lamp is used up in about 1,300 hours and not used until lamp replacement.

Indicators / TEMP, LAMP, POWER

The projector has three indicators each of which shows the working condition of the projector.

- Though the LAMP and TEMP indicators are on the main menu control window of PCGC, the each indicator may not match the one of those on the control panel.

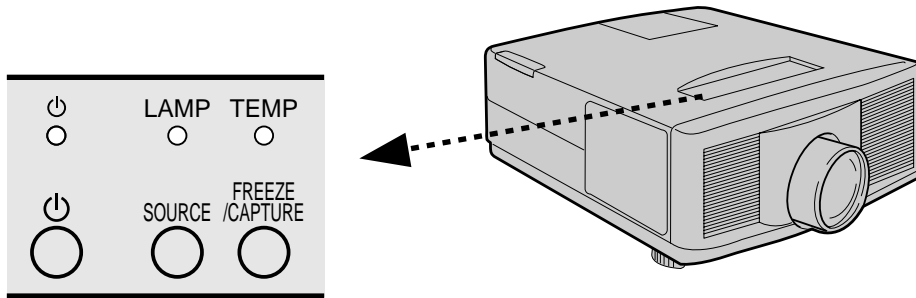

The following offers solutions to possible problems. If a problem persists, turn the projector off and consult your dealer.

INDICATOR	SHOWS	CONDITION	POSSIBLE SOLUTIONS
TEMP INDICATOR	blinking red	<ul style="list-style-type: none"> • Unusual temperature The power is turned off and the POWER indicator lights up red. • The ventilation slots or air filter is clogged with dust or debris. • The fan has stopped due to an impediment. 	<ul style="list-style-type: none"> • Remove the object from the ventilation slot. • Pull out the power plug and remove the object. If you cannot, consult your dealer. • Relocate the projector to a cooler place. • Clean the filter.
		<ul style="list-style-type: none"> • The location temperature is too high. • The filter is dirty. 	
LAMP INDICATOR	Steady green	Normal	-
	Blinking red	Lamp is almost used up.	Replace the lamp. Exchange with a new lamp if the same problem recurs.
	Steady red	<ul style="list-style-type: none"> • Lamp is used up. • The power is not turned on. (Power indicator lights up red.) 	
POWER INDICATOR	Steady red	Standby	-
	Steady green	Power-on	-

Troubleshooting

The following offers solutions to some of the common problems you may encounter. We suggest that you consult this chart before contacting your dealer.

PROBLEMS	CAUSE	POSSIBLE SOLUTIONS
The power is off.	<ul style="list-style-type: none"> • The air intake vents, exhaust vents or air filter is clogged with dust or some object. <p>Power indicator does not light up.</p> <ul style="list-style-type: none"> • Power cord is unplugged from the outlet. • Power cord is disconnected from the projector. • The main switch is turned off. • The lamp lid is open. <p>Power indicator blinks red.</p> <ul style="list-style-type: none"> • The projector has been turned on again too soon after having been turned off. • The room temperature is too high. (Does the lamp indicator show an unusual condition?) • The filter cover is not closed. 	<ul style="list-style-type: none"> • Remove the object. • Plug the power cord into the outlet. • Insert the power cord into the projector. See page 15. • Turn the main switch on. • Close the lamp lid. • Wait for the lighting sequence. • Refer to "INDICATORS" on page 49. • Close the cover correctly.
No picture appears on the screen.	<ul style="list-style-type: none"> • Lens is covered by lens cap. • Lamp is no longer working. • The equipment connected to this projector is not turned on. • Hookup is not made correctly with other equipment. • The input source is not selected correctly. 	<ul style="list-style-type: none"> • Take the lens cap off. • Replace the lamp with a new one. • Turn on the connected equipment. • Confirm the hookup. • Select the correct source according to the equipment connected to this projector.
The image is distorted.	<ul style="list-style-type: none"> • The projector is not at a right angle to the screen. 	<ul style="list-style-type: none"> • Adjust the angle of the projector to make a right angle to the screen. See page 15.
The image is dark.	<ul style="list-style-type: none"> • Brightness, tint and color are not adjusted correctly. 	<ul style="list-style-type: none"> • Adjust brightness, tint and color correctly.
The image is blurred.	<ul style="list-style-type: none"> • The projecting distance is beyond the focused area. • Lens is dirty. • Brightness, contrast and DLE are not adjusted correctly. • FINE adjustment is not made correctly. • Tracking is not adjusted. • The projector is not at a right angle to the screen. 	<ul style="list-style-type: none"> • Adjust the projecting distance. See page 14. • Clean lens. • Adjust brightness, contrast. • Make FINE adjustment. • Adjust tracking. • Adjust the angle of the projector to make a right angle to the screen. See page 15.

PROBLEMS	CAUSE	POSSIBLE SOLUTIONS
The image remains blurred.	<ul style="list-style-type: none"> When you see the stationary image for a long time, it may remain on the screen if you change the image. It is not a breakdown. The blurred image will disappear in a few minutes. 	
Red, blue or green dots are viewed on the text of image.	<ul style="list-style-type: none"> It is normal. 	
The image is distorted on the screen and noise is heard.	<ul style="list-style-type: none"> The cable for connection with other equipment is not plugged securely into the terminal. The projector is installed too close to other equipment. 	<ul style="list-style-type: none"> Plug the connecting cable securely into the terminal. See pages 17-21. Install the projector far away from other equipment.
No sound is heard.	<ul style="list-style-type: none"> Volume is not turned up. Mute function on PCGC is on. Connection to other equipment is not made correctly. 	<ul style="list-style-type: none"> Turn up the volume. Cancel the mute function. See page 30. Check connections. See page 21.
Nothing is displayed on the PC monitor.	<ul style="list-style-type: none"> The PC monitor is not turned on. 	<ul style="list-style-type: none"> Turn on the monitor.
Warm air comes out of the exhaust vents.	<ul style="list-style-type: none"> This is typical of the LCD projector. 	
Adjustments cannot be made.	<ul style="list-style-type: none"> The operation is incorrectly made due to noise or interference. 	<ul style="list-style-type: none"> Reset the mode and try again.

Specifications

Type	LCD projector
Model	LVP-X100A
Rated power supply	AC100 ~ 240V, 50 / 60Hz
Rated input	5.0A
LCD panels	1.3-inch LCD panel: 3 pieces (for R, G, B) Pixels 1,024 × 768 = 786,432 pixels Total 2,359,296 pixels Active pixel rate: 99.99 % or more (each panel)
Projection lens	F 2.5~2.9 f = 52.8 ~ 68.6 mm
Light source lamp	280 W DC metal halide lamp
Picture size	aspect ratio 4:3 20~300 inch
Audio output	1 W + 1 W stereo
Speakers	6 cm round type (8Ω 1W) × 2 pcs.
S-video input	Luminance signal: 1.0 Vp-p 75Ω (negative sync.) Chroma signal: 0.286 Vp-p 75Ω (burst signal)
Video input	1.0 Vp-p 75Ω (negative sync.)
Audio inputs	350 mVrms, 10kΩ or more
Analog RGB input (mini D-SUB 15P)	RGB: 0.7Vp-p 75Ω (positive sync.) YCbCr: Y:1.0Vp-p (negative sync.) Cb, Cr:0.7Vp-p HD/CS : TTL level (positive) VD : TTL level (positive)
PC audio inputs	350 mVrms, 10kΩ or more ø3.5mm stereo mini jack
Outside dimensions	330 × 145 × 385 mm (width × height × depth) Legs and lenses are not included.
Weight	21.5 lb (9.8kg)
Length of power code	70.8 inch (1.8m)
Temperature, humidity (performance guarantee)	+41°F (+5°C) ~ +95°F (+35°C), 30~90%

Replacement parts list

What's included in the box

1 AC power cable	246C284-10
1 RCA video cable	246C323-10
1 RCA/BNC adaptor	452D173-10
1 Audio cable	242C938-10
1 RGB cable for PC	246C318-10
1 MAC adaptor for RGB cable	246C319-10
1 RS-232C cable	246C320-10
1 MAC adaptor for RS-232C cable	246C321-10
1 Remote control	939P700-10
1 Lens cap	499B009-20
1 Warranty card	854B244-30
1 User's manual	871D237-20
1 Software disc set	919P033-10
1 Battery for remote	–

Accessories

1 Spare metal halide lamp	499B011-10
1 PC audio cable	242D493-10



MITSUBISHI ELECTRONICS AMERICA, INC.
5665 Plaza Drive
Cypress, CA 90630