

***myprojectorlamps.com***

**The most trusted, dependable name  
in projector lamp sales.**



<http://www.myprojectorlamps.com>



<http://www.myprojectorlamps.ca>



<http://www.myprojectorlamps.eu>

The following projector manual has not been modified or altered in any way.

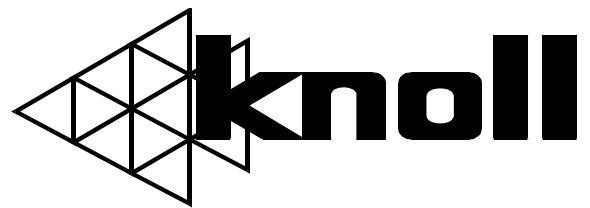

# HD110

16:9 / 4:3  
Dual Mode  
DLP Projector



**FCC Warning**

This equipment has been tested and found to comply with the limits for a Class B digital device, pursuant to part 15 of the FCC Rules. These limits are designed to provide reasonable protection against harmful interference in a residential installation. This equipment generates, uses and can radiate radio frequency energy and, if not installed and used in accordance with the instructions, may cause harmful interference to radio communications. However, there is no guarantee that interference will not occur in a particular installation. If this equipment does cause harmful interference to radio or television reception, which can be determined by turning the equipment off and on, the user is encouraged to try to correct the interference by one or more of the following measures:

Reorient or relocate the receiving antenna.

Increase the separation between the equipment and receiver.

Connect the equipment into an outlet on a circuit different from that to which the receiver is connected.

Consult the dealer or an experienced radio/TV technician for help.

**Canada**

This Class B digital apparatus complies with Canadian ICES-003.

Cet appareil numérique de la classe B est conforme à la norme NMB-003 du Canada.

**Safety Certifications**

UL, CUL, TÜV, NOM, IRAM

**Declaration of Conformity**

Knoll Systems, 11791 Machrina Way, #120, Richmond, BC V7A 4V3 Canada

We declare under our sole responsibility that the HD110 projector conforms to the following directives and norms:

EMC Directive 89/336/EEC, Amended by 93/68/EEC

EMC: EN 55022

EN 55024

EN 61000-3-2

EN 61000-3-3

Low Voltage Directive 73/23/EEC, Amended by 93/68/EEC

Safety: EN 60950: 1992 + A1 + A2 + A3 + A4: 1997

August 2001

**Australian Certification C-tick mark**

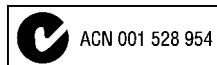
**Trademarks**

Apple, Macintosh, and PowerBook are trademarks or registered trademarks of Apple Computer, Inc. IBM and PS/2 are trademarks or registered trademarks of International Business Machines, Inc. Microsoft, PowerPoint, and Windows are trademarks or registered trademarks of Microsoft Corporation. Digital Light Processing is a trademark or registered trademark of Texas Instruments. Faroudja is a trademark or registered trademark of Faroudja Laboratories, Inc. Knöll is a trademark or registered trademark of Pacific Sound & Signal Inc.

## TABLE OF CONTENTS

<b>Safety Instructions</b>	<b>4</b>
<b>Introduction</b>	<b>5</b>
Image Resolution	5
Compatibility	5
Usage Guidelines	6
<b>Setting up the Projector</b>	<b>6</b>
Projector Positioning	7
Connecting the Enhanced Connectivity Module	8
Connecting a Video Device	9
To watch regular TV	11
To watch a DVD or VHS tape	13
To watch HDTV	15
To play a video game	17
To connect a camcorder	17
Connecting a Computer	18
Displaying your Computer Source	18
Turning Off the Projector	19
<b>Using the Projector</b>	<b>20</b>
Basic Image Adjustment	20
Adjusting the Projector	20
Using the Remote Control	21
Using the Keypad and Remote Buttons	21
Using the On-Screen Menus	23
Display Menu	23
Audio Menu	24
Image Menu for Video Sources	25
Image Menu for Computer Sources	27
Color Management Menu	28
Control Menu	29
Advanced Menu: ceiling, floor front and rear	29
Language Menu	30
<i>Status Menu</i>	30
<b>Maintenance &amp; Troubleshooting</b>	<b>31</b>
Cleaning the Lens	31
Replacing the Projection Lamp	31
Cleaning the Projection Lamp Filter Screens	33
Replacing the Batteries in the Remote Control	33
Troubleshooting	34
<b>Appendix</b>	<b>37</b>
Specifications	37
<b>Index</b>	<b>38</b>
<b>Warranty</b>	<b>39</b>

## SAFETY INSTRUCTIONS

Please read and follow all safety instructions provided **BEFORE** using your new projector. Failure to comply with safety instructions may result in fire, electrical shock, or personal injury and may damage or impair protection provided by equipment. Please save all safety instructions.

### Safety Definitions:

**Warning:** Statements identify conditions or practices that could result in personal injury.

**Caution:** Statements identify conditions or practices that could result in damage to your equipment.

### Safety Symbols:

 **Attention:** For information about usage of a feature, please refer to the User's Guide.

 **Warning:** Hot surface. Do not touch.

 An arrow pointing to the lamp door on the projector.

### Safety Terms:

 **Warning:** Don't look directly into the lens when the lamp is turned on.

 **Warning:** To replace the lamp, turn off the projector and unplug the power cord. To avoid burns, wait 30 minutes before opening the lamp door. Follow all instructions provided in this User's Guide.

 **Warning:** Please use the power cord provided. Connect the power cord to a receptacle with a protective safety (earth) ground terminal.

**Warning:** Refer all service to qualified service personnel. Servicing your own projector will void the warranty. See the following page for the technical support contact information.

**Caution:** Don't block ventilation openings. Use of an unauthorized ceiling mount may lead to ventilation blockage and/or personal injury.

**Caution:** Don't subject projector to prolonged exposure to smoke.

**Caution:** Don't set liquids on the projector. Spilled liquids may damage your projector.

**Caution:** Don't place the projector on a hot surface or in direct sunlight.

**Caution:** Do not drop the projector. Transport the projector in a Knöll approved case

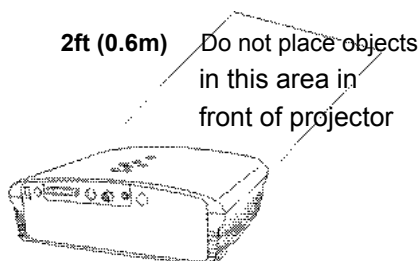

### Important Operating Considerations

Do not place the projector on a tablecloth or other soft covering that may block the vents.

Do not use a non-Knöll ceiling mount. In the unlikely event of the bulb rupturing, thoroughly clean the area

around the projector and discard any edible items placed in that area.

## INTRODUCTION

The Knöll HD110™ multimedia projector is specifically designed for home theater applications. It generates crisp, clear images using Digital Light Processing™ (DLP) technology and Faroudja™ video processing. It is easy to connect, easy to use, easy to transport, and easy to maintain.

**NOTE:** The HD110 automatically expands 640x480 computer images to 800x600. You can display these images at their native resolutions by using the Resize feature. See “Resize” on page 27 for more information.

### Image Resolution

The projector has a Dual Mode DMD that provides two resolutions: 848x480 for 16:9 format and 800x600 for 4:3 format (see page 9 for more information on video formats).

For computer sources, the SVGA resolution of the HD110's projected image is 800x600. The projector is compatible with screen resolutions up to 1024x768. If your computer's screen resolution is higher than 1024x768, reset it to a lower resolution before you connect the projector.

### Compatibility

The projector is compatible with a wide variety of computers and video devices, including:

Most standard VCRs, DVD players (progressive and interlaced), HDTV sources, DVI sources (including HDCP material), TV and satellite tuners, camcorders, video games, and laser disc players.

IBM-compatible computers, including laptops, up to 1024x768 resolution.

Apple® Macintosh® and PowerBook® computers up to 1024x768 resolution.

**NOTE:** The projector is compatible with 1080i, 1035i, and 720P HDTV formats.

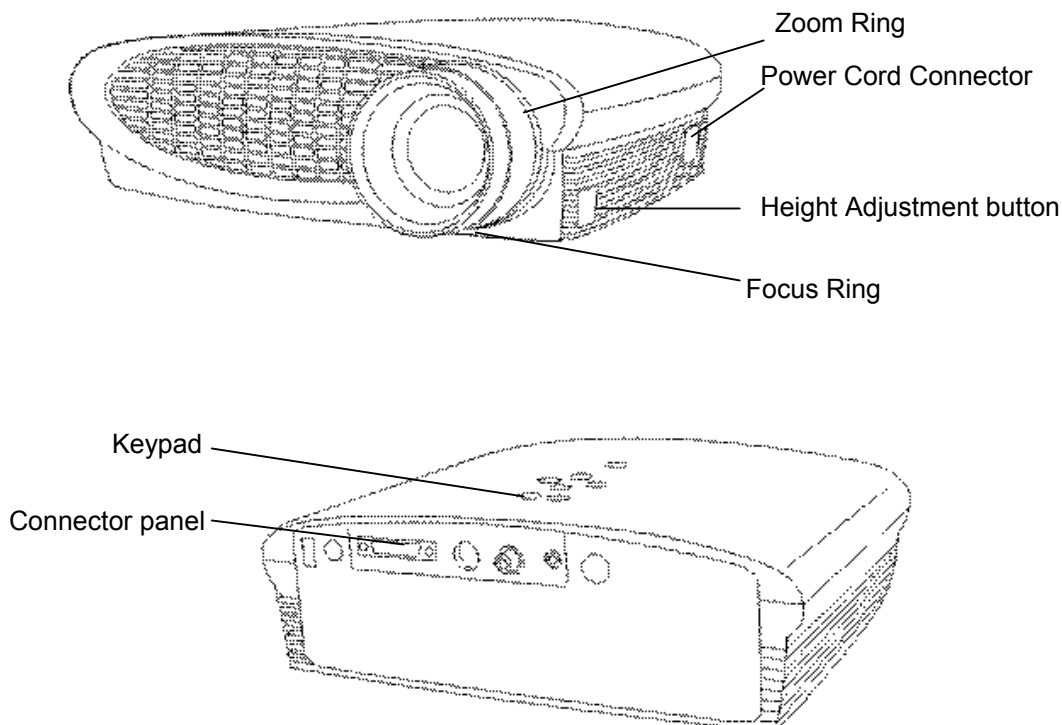

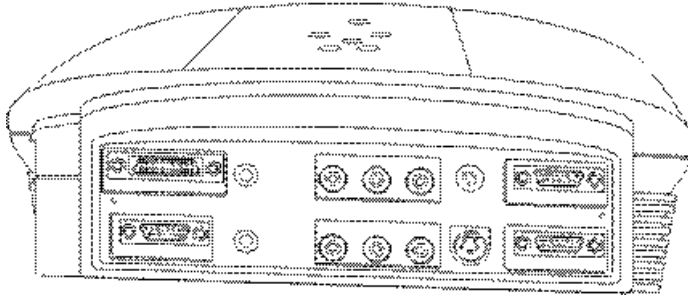

*Rear view with enhanced connectivity module attached .*  
a minute before turning it back on.

### Usage Guidelines

1. Do not look directly into the projection lens when the lamp is turned on. The bright light may harm your eyes.
2. Do not block the grills on the projector. Restricting the airflow can cause it to overheat and turn off. If this happens, you must wait.

3. Handle the projector as you would any product with glass components. Be especially careful not to drop it.
4. Avoid leaving the projector in direct sunlight or extreme cold for extended periods of time. If this happens, allow it to reach room temperature before use.
5. Transport the projector in a vendor-approved hard or soft case.
6. Do not subject projector to prolonged exposure to smoke. Smoke may cause damage to the projector.

## SETTING UP THE PROJECTOR

There are a number of factors to consider when determining where to set up the projector, including the size and shape of your screen, the location of your power outlets, and the distance between the projector and the rest of your equipment. But here are some general guidelines.

**NOTE:** To ensure adequate cable access, do not place the projector within 6 inches (.15m) of a wall or other object.

Position the projector on a flat surface at a right angle to the screen.

The projector should be within 10 feet (3 m) of your power source and within 6 feet (1.8 m) of your video source(s), unless good quality extension cables are to be used.

When installing the projector on the ceiling, refer to the installation guide that comes with the Ceiling Mount Kit for more information. To turn the image upside down, see “Ceiling Project” on page 29. Knöll recommends use of an authorized Knöll ceiling mount. The Ceiling Mount Kit is sold separately.

Position the projector the desired distance from the screen.

**NOTE:** The projector must be at least 5.6 feet (1.7 m) from the projection screen.

The distance from the lens of the projector to the screen, the zoom setting, and the video format determine the size of the projected image.

## Projector Positioning

The projected image becomes larger as the distance between the unit and screen increases.

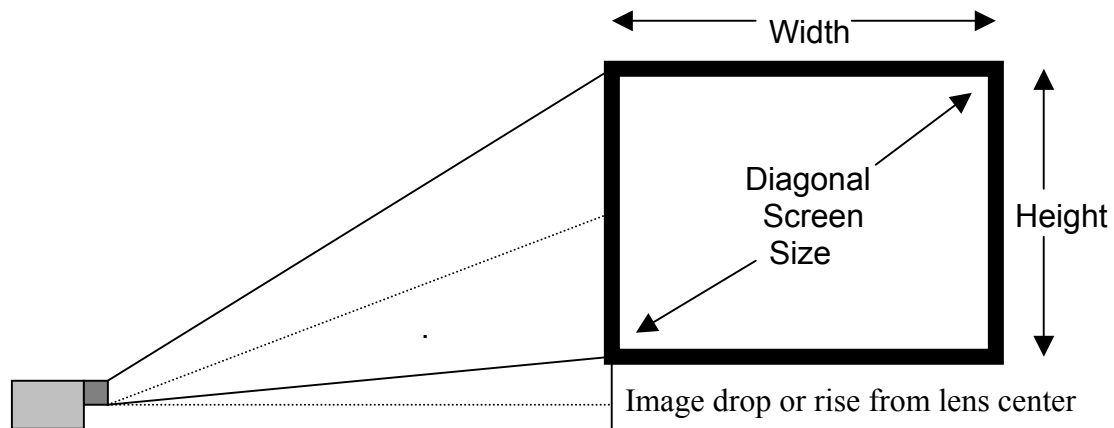

Use the following information to position the projector. Horizontally the projector needs to be positioned with the lens-centered left to right

### Projection Distance 4:3 Video Screen

<b>Screen Diagonal</b>	72"	78"	84"	100"	120"	160"
<b>Min. Distance</b>	105"	114"	123"	145"	175"	233"
<b>Max. Distance</b>	127"	138"	149"	177"	213"	284"
<b>Drop or Rise</b>	5.4"	5.9"	6.4"	7.6"	9.0"	11.9"

**Note:** Maximum distance to screen is about 1.77 x screen diagonal.  
Minimum distance to screen is about 1.46 x screen diagonal.

### Projection Distance 16:9 Video Screen

<b>Screen Diagonal</b>	88.25"	103"	110"	122.5"	146.75"	165.25"
<b>Min. Distance</b>	134"	156"	167"	186"	223"	251"
<b>Max. Distance</b>	161"	188"	201"	224"	267"	302"
<b>Drop or Rise</b>	8.6"	9.4"	12.6"	14.0"	16.8"	18.8"

**Note:** Maximum distance to screen is about 1.83 x screen diagonal.  
Minimum distance to screen is about 1.52 x screen diagonal.



## SETTING UP THE PROJECTOR

1. Place the projector on a flat surface or using a ceiling mount kit, on the ceiling.

If you want to project from behind a translucent screen, set up the projector behind your screen.

2. Position the projector the desired distance from the screen.

The distance from the lens of the projector to the screen and the zoom setting determine the size of the projected image. See the table above for maximum and minimum distances for a given screen size.

3. Make sure the projector and source equipment or computer are turned off.

Make sure the projector is unplugged and your equipment is turned off.

**WARNING:** Do not place the projector on a tablecloth or other soft covering that may block the vents. Do not use a non-Knöll ceiling mount. In the unlikely event of the bulb rupturing, thoroughly clean the area in front of the projector and discard any edible items placed in that area.

### Connecting the Enhanced Connectivity Module

The connector panel on the back of the projector (without connectivity module) looks like this:

The projector ships with an enhanced connectivity module. When you attach it to the back of the projector, it looks like this:

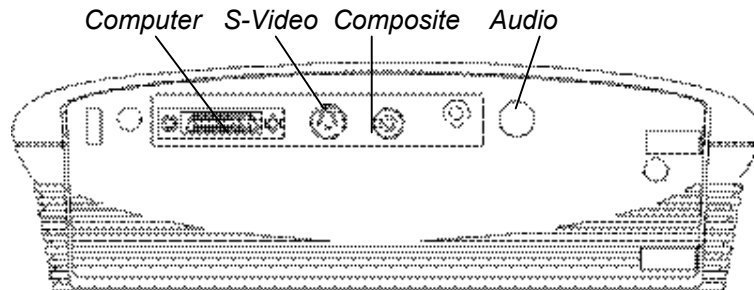

This module adds all the connectivity you need for your home theater applications.

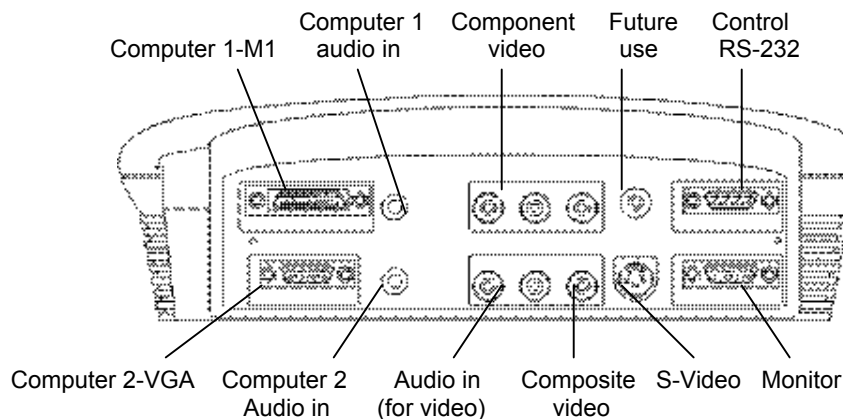

**NOTE:** If you have turned Auto Source off (page 29), you may need to press the source button more than once to display an active source. The sources switch in this order: PC 1-Analog, PC 1-Digital, Video 3-Component HDTV, Video 3-Component, Video 1 S-Video, Video 2-Composite, PC 2-Component, and PC 2-Analog.

The module connects to the projector via the projector's computer connector. Slide the tabs in the module into the grooves on the back of the projector, and then press the computer connector into the projector. To remove the module, press down all the way on the textured lever on the top left of the module to release the latch, then slide the module off.

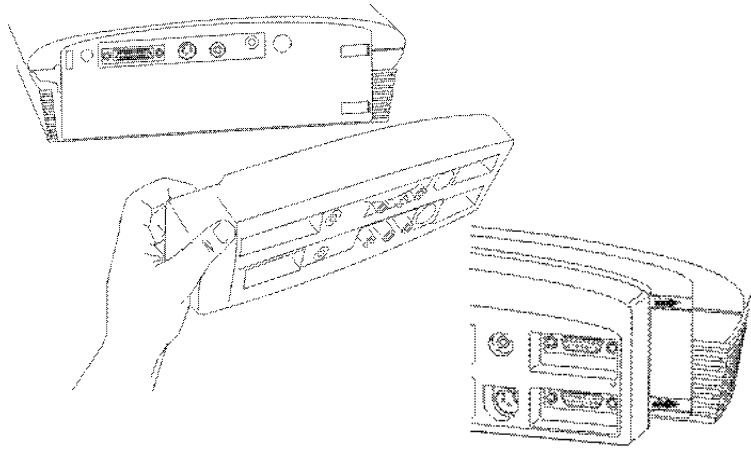

**Figure 9:** Connecting the connectivity module to the projector

The module provides two computer and three video inputs. The module also provides monitor out (used to display images on your desktop computer's monitor as well as on the projection screen), and RS-232 input (to control the projector from an external control system).

**NOTE:** Monitor out is only available for analog computer, 480p, and HDTV sources.

### Connecting a Video Device

VCRs, DVD players, camcorders, digital cameras, video games, HDTV receivers, and TV tuners can be connected to the projector. There is an audio input. Audio can be connected directly to the projector to get sound from the 3-watt onboard speaker, or you can connect it to get sound from your home theater speaker system.

Before connecting your projector, you should decide which screen aspect you want to project. Screen aspect is the ratio of the image width to image height. TV screens are usually 1.33:1, also known as 4:3. HDTV and most DVDs are 1.78:1, or 16:9. If you're projecting onto a screen, the size/shape of the screen may answer this question for you. In the non-recommended blank wall option, screen sizes are unrestricted. What you plan to project will also help you choose between 4:3 and 16:9. Most regular TV shows are 4:3, most movies are 16:9.

If you select 4:3 and play TV, the image will fill the screen. If you select 16:9 and play HDTV, the image will fill the screen. However, if you select 4:3 and play a 16:9 DVD, the image may be compressed horizontally or have black bars along the top and bottom (see Figure 10). If you select 16:9 and play regular TV, the image may be stretched horizontally or have black bars along the sides. You will make this selection later, using the onscreen menus (page 24), but for now, you just need to know which format you'll use most often.

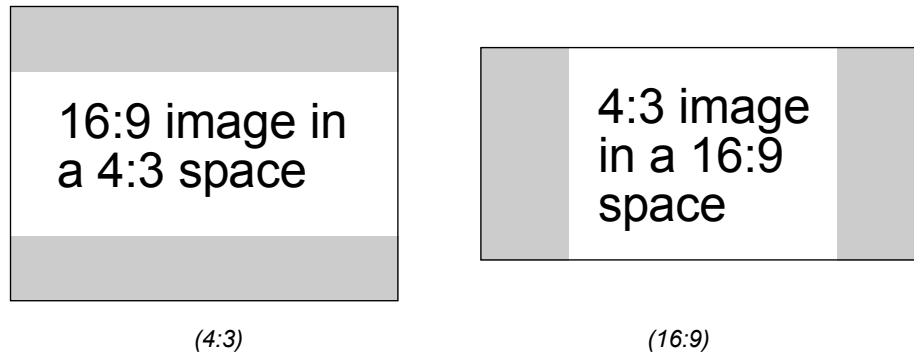

**Figure 10** 4:3 and 16:9 screen aspects

The projector can be connected to most video devices that can output video. You cannot directly connect the coaxial cable that enters your house from cable TV or a satellite dish, as the signal must pass through a tuner first. Examples of tuners are digital cable boxes, VCRs, digital video recorders, and satellite TV boxes. Basically, any device that can change channels is considered a tuner.

The next step is to identify the connector's types the equipment you want to connect has. If there is more than one output, select the highest quality one. Component video has the best quality, followed by S-video, then composite video.

Here is a list of possible input signals and the connectors they should be connected to on the projector

Input Signal	Connector	Connector label On Projector	Source Name on Screen
Standard TV: satellite TV, Digital or cable TV (not HDTV)	Composite Video	video 2	Video 2-Composite
	S-Video	video 1	Video 1-S-Video
	Component Video	video 3	Video 3-Component
HDTV	Component video	video 3	Video 3-Component
	VGA	PC2	PC2-Analog
	DVI	PC1	PC1-Analog or PC-1-Digital
DVD	Composite video	video 2	Video 2-Composite
	S-video	video 1	Video 1-S-Video
	Component Video	video 3	Video 3- Component
VCR	Composite video	video 2	Video 2-Composite
	S-video	video 1	Video 1-S-Video
Video Camera	Composite video	video 2	Video 2-Composite
	S-video	video 1	Video 1-S-Video
Video Game	Composite video	video 2	Video 2-Composite
	S-video	video 1	Video 1-S-Video

These cables are included with the projector:

**Composite Video**

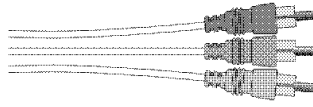

**S-Video Cable**

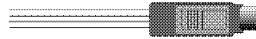

**VESA cable**

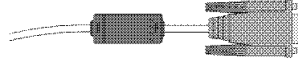

## To watch regular TV

**NOTE:** If needed, you can purchase longer cables at your local electronics store.

Determine the cables you'll need (refer to the table on page 10 if necessary). This depends on what type of output is coming from the tuner (remember, you cannot directly connect the coaxial cable that enters your house from cable TV or a satellite dish, as the signal must pass through a tuner first.) Also, determine if you want the sound to come out of the projector or out of the home theater sound system. The projector has a 3-watt onboard speaker.

### If your TV tuner has S-video output:

1. Plug one end of the S-video cable to the "S-video out" connector on your tuner (Figure 12). This connector may be labeled "To Monitor."
2. Plug the other end of the cable into the S-video connector (labeled video 1) on the projector.

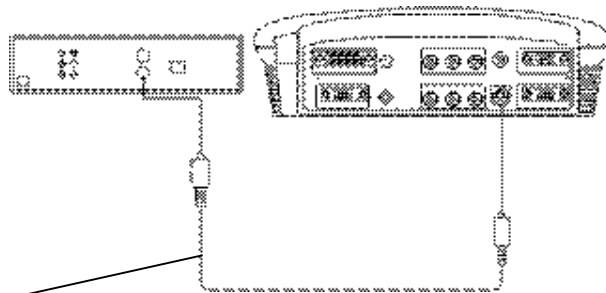

**Figure 12:** Connecting the projector to a TV tuner using the S-video cable

S-Video cable

3. If you want sound from the projector's speaker, plug the A/V cable's white connector into the left "audio out" connector on your video device. Plug the cable's red connector into the right "audio out" connector on the video device (Figure 13).
4. Plug the A/V cable's other white connector into the white "audio L" connector on the projector. Plug the cable's other red connector into the red "audio R" connector on the projector. The yellow connectors on the A/V cable remain unused.

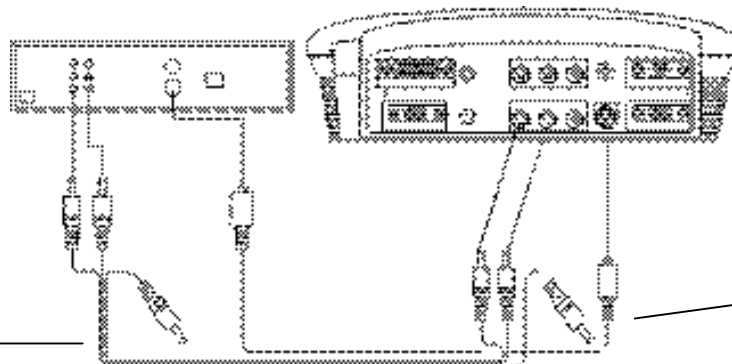

**Figure 13:** Connecting the projector to a TV tuner using the S-video cable and the A/V cable

A/V cable

S-Video cable

5. Plug the power cord into the side of the projector, then plug it into your electrical outlet. A surge-protected power strip is recommended.

The LED on the top of the projector (Figure 24 on page 21) lights green.

Now you are ready to turn on the equipment and watch TV.

6. Remove the projector's lens cap.
7. Turn on the lamp by pressing the green **power** button on the keypad or remote.

A tone sounds when you press the button, and the LED blinks green while the software initializes. When initialization is complete, the LED lights solid green and the Knöll startup screen appears.

8. Turn on your TV tuner.

The TV image should display on the projection screen. If it doesn't, press the **source** button on the keypad or the **video** button on the remote to display your TV image (press the button until "S-video" appears in the corner). You can select a default source to determine which source the projector examines first during power-up for active video; see "Default Source" on page 29.

If necessary, adjust the height of the projector. See page 20.

If necessary, adjust the zoom or focus of the image by turning the rings around the lens. See page 20.

If you are projecting on a 4:3 screen, change the screen aspect to 4:3. See page 23.

If necessary, make adjustments to the image using the projector's on-screen menus. To open the menus, press the **menu/select** button on the keypad or remote, and then select the Display or Image sub-menu. For more information about the menus, see page 23.

If the image is not square, use the keystone buttons on the remote to adjust the image's shape. See page 22.

If you connected the audio cables to the projector, use the **volume** buttons on the keypad to adjust the volume. If you connected the audio cables from your tuner to your receiver, use the receiver's volume control.

The projector is compatible with these major broadcast video standards: NTSC, NTSC 4.43, PAL, PAL-M, PAL-N, PAL-60, and SECAM. It automatically adjusts to optimize its performance for the incoming video. The input signals for SECAM, PAL-M, PAL-N, and PAL 60 video are similar to other video signals and cannot be automatically detected, therefore they must be chosen manually. See page 27.

**If your TV tuner has composite video output:**

1. Plug the A/V cable's round yellow connector into the composite "video-out" connector on your tuner (Figure 14). This connector may be labeled "To Monitor."
2. Plug the other yellow connector into the yellow composite connector (labeled video 2) on the projector.

**Figure 14:** Connecting the projector to a TV tuner using the audio video (A/V) cable

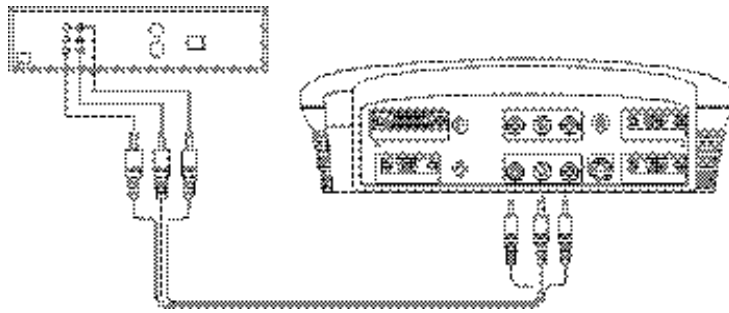

“audio L” connector on the projector. Plug the cable’s other red connector into the red “audio R” connector on the projector.

5. Follow steps 5-8 starting on page 12.

**If your TV tuner has component video output:**

Connect the component cable (not included) to the appropriate connectors (labeled video 3) on the projector and on your tuner. Your local electronics store should carry these cables.

**To watch a DVD or VHS tape**

Determine the cables you’ll need. This depends on what type of output is coming from the video device. Also, determine if you want the sound to come out of the projector or out of your own audio system. You can connect the audio directly to the projector to get sound from the 3-watt onboard speaker, or you can connect it to your stereo’s receiver to get sound from your own speakers.

**NOTE:** If needed, you can purchase longer cables at your local electronics store.

**If your video device has S-video output:**

1. Plug one end of the S-video cable to the “S-video out” connector on your video device (Figure 15). This connector may be labeled “To Monitor.”
2. Plug the other end of the cable into the S-video connector (labeled video 1) on the projector.

**Figure 15:** Connecting the projector to a video player using the S-video cable

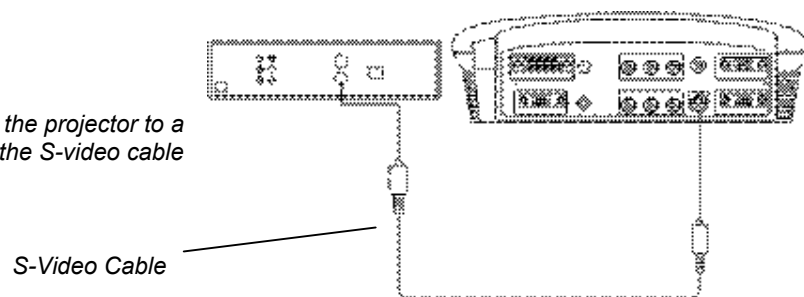

3. If you want sound from the projector’s speaker, plug the A/V cable’s white connector into the left “audio out” connector on your video device. Plug the cable’s red connector into the right “audio out” connector on the video device (Figure 13).
4. Plug the A/V cable’s other white connector into the white “audio L” connector on the projector. Plug the cable’s other red connector into the red “audio R” connector on the projector. The yellow connectors on the A/V cable remain unused.

Figure 16:  
Connecting  
the projector  
to a video  
player using  
the S-video  
cable and the  
A/V cable

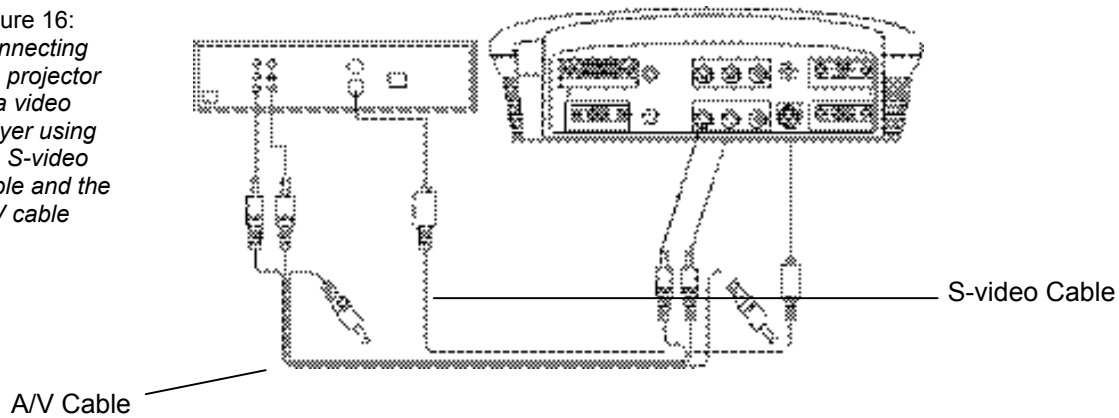

5. Plug the power cord into the side of the projector, then plug it into your electrical outlet. A surge-protected power strip is recommended.

The LED on the top of the projector (Figure 24 on page 21) lights green.

Now you are ready to turn on the equipment and watch a DVD or tape.

6. Remove the projector's lens cap.
7. Turn on the lamp by pressing the green **power** button on the keypad or remote.

A tone sounds when you press the button, and the LED blinks green while the software initializes. When initialization is complete, the LED lights solid green and the Knöll startup screen appears.

8. Plug in and turn on your video device.

The video image should display on the projection screen. If it doesn't, press the **source** button on the keypad or the **video** button on the remote to display your video image. You can select a default source to determine which source the projector examines first during power-up for active video; see "Default Source" on page 29.

If necessary, adjust the zoom or focus of the image by turning the rings around the lens. See page 20.

If you are projecting on a 4:3 screen, change the screen aspect to 4:3. See page 24.

If the image is not square, use the keystone buttons on the remote to adjust the image's shape. See page 21.

9. Insert the tape or disk you want to play, and then start playing it. Some DVDs start automatically, some require you to select Play Movie from the startup screen.

Select a different resize option, if desired. The choices are standard, widescreen letterbox, enhanced widescreen, and native. See page 27 for details.

If you connected the audio cables to the projector, use the **volume** buttons on the keypad to adjust the volume. If you connected the audio cables from your video device to your receiver, use the receiver's volume control.

If necessary, make adjustments to the image using the projector's on-screen menus. To open the menus, press the **menu/select** button on the keypad or remote, and then select the Display or Image sub-menu. For more information about the menus, see page 23.

**If your video device has composite video output:**

1. Plug the A/V cables round yellow connector into the composite “video-out” connector on your video device (Figure 17). This connector may be labeled “To Monitor.”
2. Plug the other yellow connector into the yellow composite connector (labeled video 2) on the projector.

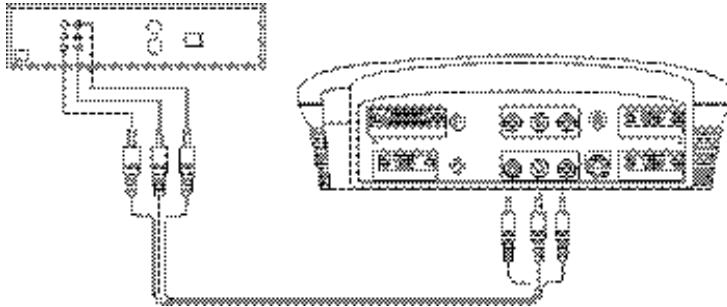

**Figure 17:** Connecting the projector to a video player using the audio video (A/V) cable

3. If you want sound from the projector’s speaker, plug the A/V cable’s white connector into the left “audio out” connector on your video device. Plug the cable’s red connector into the right “audio out” connector on the video device.
4. Plug the A/V cable’s other white connector into the white “audio L” connector on the projector. Plug the cable’s other red connector into the red “audio R” connector on the projector.
5. Follow steps 5-10 starting on page 14.

**To watch HDTV**

Determine the cables you’ll need (refer to the table on page 10 if necessary). This depends on what type of output is coming from the tuner (remember, you cannot directly connect the coaxial cable that enters your house from a cable or satellite company, the signal must pass through a tuner first.) Also, determine if you want the sound to come out of the projector or out of your own audio system. You can connect the audio directly to the projector to get sound from the 3-watt onboard speaker, or you can connect it to your stereo’s receiver to get sound from your own speakers.

**NOTE:** If needed, you can purchase longer cables at your local electronics store.

**If your HDTV tuner has a 15-pin VGA output:**

1. Plug one end of the VESA cable to the VGA connector on your HDTV source (Figure 18). This connector may be labeled “To Monitor.”
2. Plug the other end of the cable into the VESA connector (labeled PC 2) on the projector.

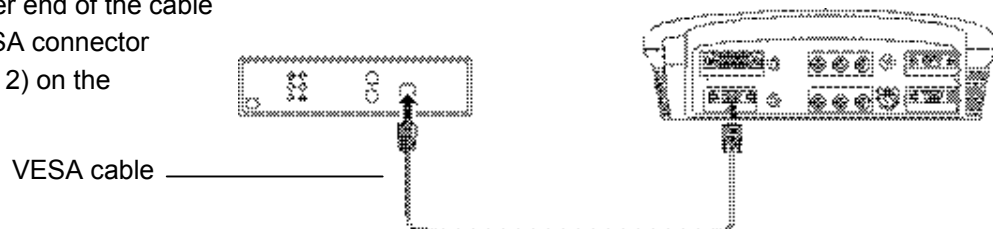

**Figure 18:** Connecting the projector to an HDTV source using the VESA cable



3. If you want sound from the projector's speaker, plug the A/V cable's white connector into the left "audio out" connector on your tuner. Plug the cable's red connector into the right "audio out" connector on the tuner.
4. Plug the A/V cable's other white connector into the white "audio L" connector on the projector. Plug the cable's other red connector into the red "audio R" connector on the projector. The yellow connectors on the A/V cable remain unused.
5. Plug the power cord into the side of the projector, then plug it into your electrical outlet. A surge-protected power strip is recommended.

The LED on the top of the projector (Figure 24 on page 21) lights green.

Now you are ready to turn on the equipment and watch HDTV.

6. Remove the projector's lens cap.
7. Turn on the lamp by pressing the green **power** button on the keypad or remote.

A tone sounds when you press the button, and the LED blinks green while the software initializes. When initialization is complete, the LED lights solid green and the Knöll startup screen appears.

8. Turn on your HDTV tuner.

The HDTV image should display on the projection screen. If it doesn't, press the **source** button on the keypad or the **video** button on the remote to display your HDTV image. You can select a default source to determine which source the projector examines first during power-up for active video; see "Default Source" on page 29.

If necessary, adjust the zoom or focus of the image by turning the rings around the lens. See page 20.

If you are projecting on a 4:3 screen, change the screen aspect to 4:3. See page 24.

If necessary, make adjustments to the image using the projectors on-screen menus. To open the menus, press the **menu/select** button on the keypad or remote, and then select the Display or Image sub-menu. For more information about the menus, see page 23. If you want to return to the factory default settings, choose Reset in the Advanced menu.

If the image is not square, use the keystone buttons on the remote to adjust the image's shape. See page 21.

If you connected the audio cables to the projector, use the **volume** buttons on the keypad to adjust the volume. If you connected the audio cables from your video device to your receiver, use the receiver's volume control.

**If your HDTV tuner has a DVI or component output:**

For DVI, connect an optional DVI cable into the connector labeled “PC 1”. For component, connect an optional component video cable into the connector labeled “video 3”. Follow the instructions in the previous section to connect and display these sources.

**To play a video game****To play a game from a video machine:**

Connect your equipment as described in “Connecting a Video Device” on page 9.

**To play a video game from a computer:**

Connect your equipment as described in “Connecting a Computer” on page 18.

**To connect a camcorder**

Connect your equipment as described in “Connecting a Video Device” on page 9.

**Turning Off the Projector**

If you want to turn off the projector for a short period of time, press the **standby** button on the keypad or remote. This blanks the screen for fifteen minutes, but keeps the projector running. (You can change the amount of time the projector stays in standby mode; see page 29 for details.) After 15 minutes, the lamp goes out. To exit standby mode, press the **standby** button again. (It may take several seconds for the projection lamp to reach full power and project the image again.) See page 22 for details on standby mode.

**NOTE:** Lamp life will be extended if you turn the power off, then wait 1 minute while the lamp cools before unplugging the projector. The Lamp LED will light green when the lamp has cooled.

To turn off the projector, press the **power** button (you can cancel the shutdown by pressing the **power** button again within 10 seconds). The lamp turns off and the LED blinks amber for a minute while the fans continue to run to cool the lamp. When the lamp has cooled, the LED lights green and the fans stop. Unplug the power cord to completely power off the projector.

## Connecting a Computer

The projector ships with an analog VESA computer cable. If your computer has a digital output, you can order the optional digital M1 computer cable. Using a digital source generates the highest quality and brightest image possible.

1. Plug one end of the computer cable into the PC 2 connector on the projector.

**NOTE:** Many laptop computers do not automatically turn on their external video port when a secondary display device such as a projector is connected. Refer to your computer manual for the command that activates the external video port. Activation commands for some laptop computers are listed in the Service section of our website.

2. Plug the other end of the computer cable into the video connector on your computer. If you are using a desktop computer, you need to disconnect your monitor cable from your computer first.

**Figure 18:** Connecting the projector to a computer.



**Do you want to play your computer's audio on the projector?**

1. Plug either end of an audio cable (not included) into the audio connector on your computer.
2. Plug the other end of the audio cable into the "audio in" connector on the projector.

**Do you want to display the image on your desktop computer's monitor as well as on the projection screen?**

1. Plug the monitor's cable into the "monitor out" connector on the projector.

Now you're ready to power up the projector and your computer.

## Displaying your Computer Source

**NOTE:** Always use the power cord that shipped with the projector.

1. Remove the lens cap.
2. Plug the power cord into the side of the projector, then plug it into your electrical outlet. A surge-protected power strip is recommended.

The LED on the top of the projector (Figure 24 on page 21) lights green.

3. Turn on the lamp by pressing the green **power** button on the keypad or remote.

A tone sounds when you press the button, and the LED blinks green while the software initializes. When initialization is complete, the LED lights solid green and the Knöll startup screen appears.

4. Turn on your computer.
  - a. The first time you connect a particular computer to the projector, the computer recognizes the projector as "new hardware" and the Add New Hardware Wizard appears. Follow these instructions to use the Wizard to load the correct driver (which was installed with your Windows operating system).

- b. Click Next. Make sure “Search for the best driver” is selected, and then click Next.
- c. Uncheck any checked boxes, then click Next. Windows automatically locates the driver. If this driver has been removed, reload the driver using your Windows operating system CD.
- d. When Windows finds the driver, you are ready to install it. Click Next.
- e. Click Finish when installation is complete.

**NOTE:** *With some computers, the order in which you power up the equipment is very important. Most computers should be turned on last, after all other peripherals have been turned on. Refer to your computer's documentation to determine the correct order.*

5. The computer image should display on the projection screen. If it doesn't, press the **source** button on the keypad or the **data** button on the remote to display your computer's image. Make sure your laptop's external video port is activated; see your computer's user guide for details.

If necessary, make adjustments to the image using the projectors on-screen menus. To open the menus, press the **menu/select** button on the keypad or remote, and then select the Display or Image sub-menu. For more information about the menus, see page 23. You may need to adjust the screen aspect (page 24) or the degamma (page 28).

### Turning Off the Projector

If you want to turn off the projector for a short period of time, press the **standby** button on the keypad or remote. This blanks the screen for fifteen minutes, but keeps the projector running. (You can change the amount of time the projector stays in standby mode; see page 29 for details.) After 15 minutes, the lamp goes out. To exit standby mode, press the **standby** button again. (It may take several seconds for the projection lamp to reach full power and project the image again.) See page 22 for details on standby mode.

**NOTE:** Lamp life will be extended if you turn the power off, then wait 1 minute while the lamp cools before unplugging the projector. The Lamp LED will light green when the lamp has cooled.

To turn off the projector, press the **power** button. The lamp turns off and the LED blinks amber for a minute while the fans continue to run to cool the lamp. When the lamp has cooled, the LED lights green and the fans stop. Unplug the power cord to completely power off the projector.

## USING THE PROJECTOR

This section describes how to use and make adjustments to the projector. It also provides a reference to the keypad and remote buttons and the options available from the on-screen menus.

### Basic Image Adjustment

If the image doesn't display completely, zoom the image (page 20), adjust the height of the projector (page 30), choose a different screen aspect (page 24) or choose a different resize option (page 44). Be sure the projector is at a 90° angle to the screen.

If the image is out of focus, rotate the focus ring (page 20).

If the image is not square, adjust the keystone (page 21).

If the colors don't look right, adjust the brightness, contrast, tint, color, or sharpness (page 23) or the color space or gain (page 28).

### Adjusting the Projector

To focus the image, rotate the focus ring until the image is clear. To zoom the image, rotate the zoom ring. This adjusts the image size. You can also zoom in on part of the image, see page 22.

**NOTE:** To obtain the best overall focus quality, open the menu and focus on the text. This will ensure that the best overall image quality is achieved.

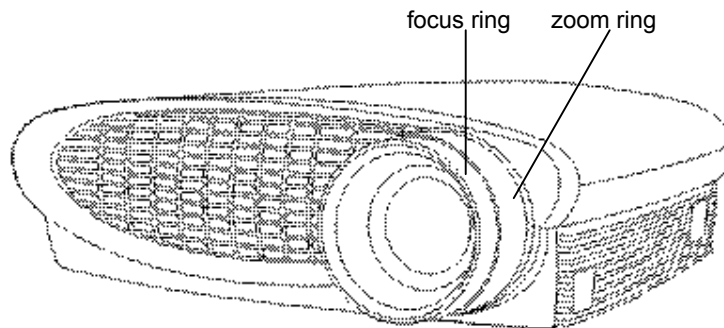

The projector is equipped with a self-locking, quick-release elevator foot and button.

To raise the projector:

**Press and hold the elevator button. Raise the projector to the height you want, then release the button to lock the elevator foot into position.**

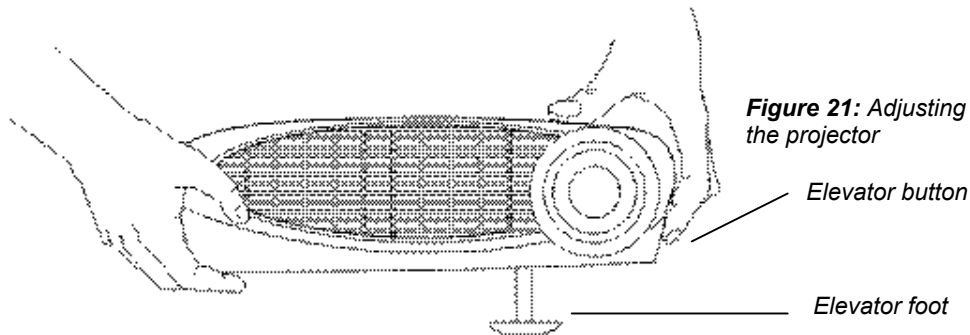

**Figure 21:** Adjusting the height of the projector

If necessary, turn the leveling knob to adjust the angle of the projected image.

**Figure 22:** Turning the leveling knob

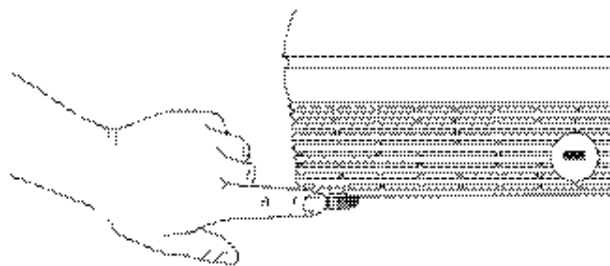

### Using the Remote Control

Install the 2 AAA batteries in the remote. See page 33 if you need help.

Point the remote control at the projection screen or at the front or back of the projector. The range for optimum operation is about 25 feet. If you point the remote at the projection screen, the distance to the screen and back to the projector must be less than or equal to 25 feet. For best results, point the remote directly at the projector.

**Figure 24:** Remote control

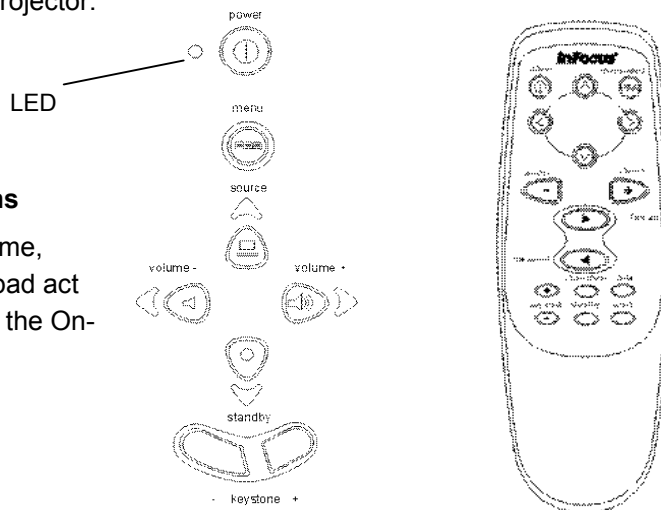

### Using the Keypad and Remote Buttons

While the menus are displayed, the volume, source, and standby buttons on the keypad act as menu navigation buttons. See “Using the On-Screen Menus” on page 23 for details.

### Menu/select

**NOTE:** If you have turned Auto Source off (page 29), you may need to press the source button more than once to display an active source. The sources switch in this order: PC 1-Analog, PC 1-Digital, Video 3-Component HDTV, Video 3-Component, Video 1 S-Video, Video 2-Composite, PC 2-Component, and PC 2-Analog.

Press the **menu/select** button to open the on-screen menus. Press **menu/ select** again (while Exit is highlighted) to close the menus. (The menus automatically close after 30 seconds if no buttons are pressed.) When you close the menus, the projector saves any changes you made. For more information about the on-screen menus, see page 23.

### Source (keypad only) or Data and Video (remote only)

When you have more than one source (computer and video) connected to the projector, select between them by pressing the **source** button on the keypad or the **data** or **video** button on the remote.

### Keystone +/-

Use this feature to adjust the image vertically and make a squarer image.

Press the **keystone +** button to reduce the upper part of the image, and press the **keystone -** button to reduce the lower part. You can also adjust keystone from the Display menu (see page 23 for details on the menu).

**Forward/back buttons (remote only)**

These buttons are not used with video sources.

These buttons act like the page up and page down buttons on your computer's keyboard. You can use them to advance through a slide show in PowerPoint™ presentations. To use this feature, you must purchase an optional M1-DA cable and connect the USB connector on that cable to the computer.

**Up/down/left/right arrow buttons (remote only)**

Use these buttons to navigate through and make adjustments to the on-screen menus. See "Using the On-Screen Menus" on page 23 for details.

**Power button**

This turns the lamp on and off. See page 11 for startup instructions and see page 17 for shutdown instructions.

**Zoom mode**

This activates the zoom feature. When you press this button, the zoom icon appears in the lower right corner of the screen. Press the **zoom +** button to zoom in on part of the image, press the **zoom -** button to zoom out. When the image is zoomed, you can use the up/down/left/right arrow buttons to display a different part of the zoomed image (pan the image). Press **zoom mode** again to exit the mode and return the image to normal size.

You can also turn Zoom mode on using the Image menu and zoom and pan the image using the keystone buttons and arrows on the keypad. See page 27 for details.

**Zoom +/- (remote only)**

This allows you to zoom in and out on a part of the image.

**Standby** 

When you press **standby**, the display and audio turn off and a blank screen is displayed for 15 minutes. You can change the amount of time the projector stays in standby mode; see page 29 for details. The LED lights amber while the projector is in standby.

If you press **standby** again within 15 minutes, the projector returns to normal operations immediately. The LED changes from amber to green.

If you don't press **standby** again, the lamp turns off after 15 minutes. The LED blinks amber and the fans run while the projector cools down, then the projector shuts off and the LED lights solid green.

**Volume (keypad only)**

To increase the volume, press **volume +** . To decrease the volume, press **volume -** .

## Using the On-Screen Menus

The projector has menus that allow you to make image adjustments and change a variety of settings. Most of these adjustments aren't available directly from the keypad.

**NOTE:** Some menu items may be grayed out (dimmed) at certain times. This indicates the item is not applicable to your setup or the item is not enabled until another selection is made.

To open the on-screen menus, press the **menu/select** button on the keypad or remote. (The menu automatically close after 30 seconds if no buttons are pressed.) This displays the Main menu and changes the volume, source, and standby buttons on the keypad to menu navigation and adjustment buttons (the arrow LED's around the buttons light green to indicate the change). Press the corresponding buttons to move the cursor up and down, or use the arrow buttons on the remote. The selected menu is highlighted.

To change a menu setting, use the up and down arrow buttons to move the cursor up and down to the item you want to change (the selected item is highlighted), then press **menu/select**. When an item is selected, its button appears depressed to provide a visual indication of selection. Use the left and right arrows to adjust the setting or turn it on and off. Press **menu/select** when you are done. Press the up and down arrows to move to another setting. When you have completed your adjustments, navigate to Exit, and then press **menu/select**. You are returned to the top of the Main menu. Press **menu/select** again to exit the Main menu, or navigate to another submenu.

### Display Menu

To access the Display menu settings, press the **menu/select** button to display the Main menu, press the down arrow to highlight Display, then press **menu/select** again to access the Display menu.

#### Keystone

This option helps to keep the image square as the angle of projection is changed. Use this feature to adjust the image vertically and make a squarer image. See page 21 for details on keystone adjustments.

Press the down button to highlight Keystone, and then press **menu/select**. Use the left and right arrows to adjust the keystone setting. Press **menu/select** to accept your changes.

#### Brightness

Adjusting the brightness changes the intensity of the image.

Use the up and down arrows to highlight Brightness, press **menu/ select**, use the arrows to adjust the brightness, then press **menu/select** to accept your changes.

#### Contrast

The contrast controls the degree of difference between the lightest and darkest parts of the picture. Adjusting the contrast changes the amount of black and white in the image.

Use the up and down arrows to highlight Contrast, press **menu/select**, use the arrows to adjust the contrast, then press **menu/select** to accept your changes.



## Tint

**NOTE:** The color setting applies to video sources only. The tint setting applies to NTSC video sources only.

The tint adjusts the red-green color balance in the projected image.

Use the up and down arrows to highlight Tint, press **menu/select**, use the arrows to adjust the tint, then press **menu/select** to accept your changes.

## Color

The color setting adjusts a video image from black and white to fully saturated color.

Use the up and down arrows to highlight Color, press **menu/select**, use the arrows to adjust the color, then press **menu/select** to accept your changes.

## Sharpness

This setting adjusts sharpness of a video image.

Use the up and down arrows to highlight Sharpness, press **menu/select**, use the arrows to cycle through the options soft, med-soft, medium, med-hard, and hard, then press **menu/select** to accept your selection.

## Screen Aspect

This setting adjusts display format of a video image or screen aspect ratio.

Use the up and down arrows to highlight Screen Aspect, press **menu/select**, use the arrows to choose between 4:3 and 16:9, then press **menu/select** to accept your selection.

## Blank screen

Blank Screen determines what color is displayed when there is no active source and when the projector is in standby.

Use the up and down arrows to highlight Blank screen, press **menu/select**, use the arrows to cycle through the options blue, black, and white, then press **menu/select** to accept your selection.

## Audio Menu

### Volume

You can also adjust the volume directly from the projector's keypad.

Use the up and down arrows to highlight Volume, press **menu/select**, use the arrows to adjust the volume, then press **menu/ select** to accept your changes.

### Mute

This mutes the sound.

Use the up and down arrows to highlight Mute, press **menu/select**, use the left or right arrow to turn mute on and off (a green dot indicates a feature is on), then press **menu/select** to accept your changes.

## Image Menu for Video Sources

To access the Image menu settings, press the **menu/select** button to display the Main menu, press the down arrow to highlight Image, then press **menu/select** again to access the Image menu.

### Resize

**Resize** allows you to select from among four different re-sizing options. The goal is to show the most detail on the screen while preserving the ratio of width to height. Often, the terms “widescreen letterbox” or “letterbox” or “enhanced for widescreen” or “anamorphic” appear on the back of DVDs. Check for these terms, then see the following table for guidelines for which resize option to select for which setup. Following the table is a description of the Resize options.

**NOTE:** Your viewing preferences may vary from those listed. Cycle through the resize options and pick the one you like the best.

If you have this source	And this screen aspects	Choose this resize option	To get this image
Standard TV	4:3	Standard	Full screens
Standard TV	16:9	Standard	4:3 image with side bars
VHS tape	4:3	Standard	Full screens
VHS tape	16:9	Standard	4:3 image with side bars
DVD in standard	4:3	Standard	Full screens
DVD in standard	16:9	Standard	4:3 image with side bars
DVD in wide screen letterbox	4:3	Wide screen letterbox	16:9 image with top/ bottom bars
DVD in wide screen letterbox	16:9	Wide screen letterbox	Full screen
DVD in enhance widescreen / anamorphic	4:3	Enhanced widescreen	16:9 image with top/ bottom bars
DVD in enhance widescreen/ anamorphic	16:9	Enhanced widescreen	Full screen
HDTV	4:3	Enhanced widescreen	16:9 image with top/ button bars
HDTV	16:9	Enhanced widescreen	Full screen

The default Resize option is **Enhanced Widescreen**, which preserves the 16:9 aspect ratio and is designed, to be used with content that is Enhanced for Widescreen TVs.

**NOTE:** A source that says “Anamorphic” means the same as “Enhanced for widescreen”.

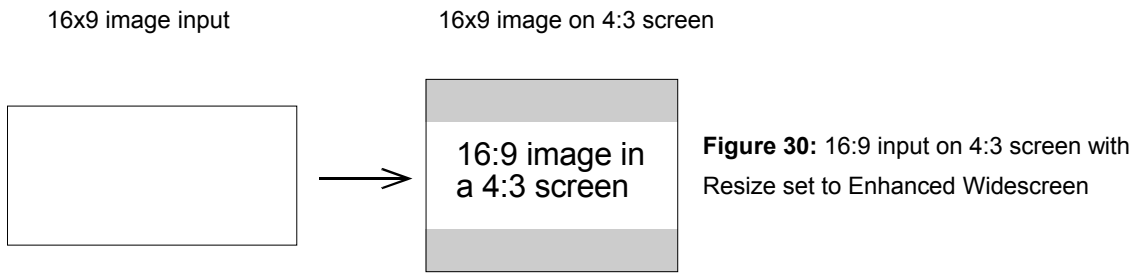

**Widescreen Letterbox** preserves the 16:9 aspect ratio. If you have a 16:9 source and screen, the image fills the screen (Figure 31). If you have a 16:9 source and a 4:3 screen, the image is placed in a 4:3 space, so black bars appear at the top and bottom of the image.

**NOTE:** A source that says “Widescreen” usually means the same as “Widescreen Letterbox”.

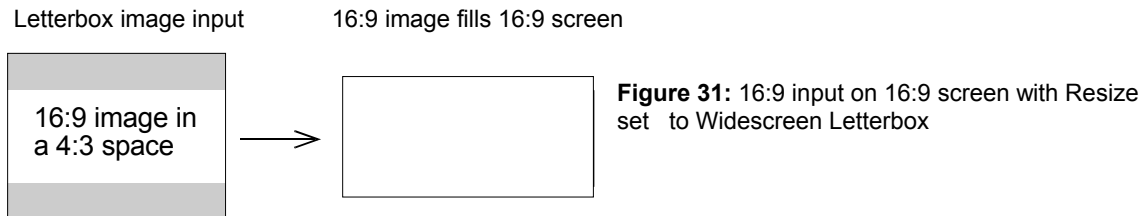

**Standard** resizes the image from its original version to fit a standard 4:3 aspect ratio screen. If you have a 4:3 source and screen, the image fills the screen. If you have a 4:3 source on a 16:9 screen, the image is placed in a 16:9 space, so black bars appear at the sides of the image.

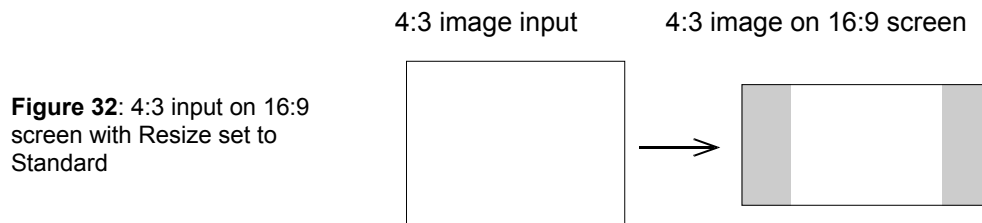

**Native** displays the image with no resizing.

Highlight **Resize**, press **menu/select**, use the left or right arrow buttons to cycle through the options, then press **menu/select** to select.

### Overscan

This option crops the image edges to remove noise generated on the edges by your source.

### Zoom

This allows you to enter zoom mode without using the remote. Highlight **Zoom**, press **menu/select**, use the left or right arrow buttons to turn zoom mode on, and then press **menu/select**. Exit the menus to use the zoom feature. The zoom icon appears in the lower right corner. Use the **key-stone +** button to zoom in and use the **key-stone -** button to zoom out. Use the keypad navigation buttons on the keypad to pan the zoomed image. To exit zoom mode, either turn the feature off in the Image menu or press the **zoom mode** button on the remote.

## Video Standard

**NOTE:** If you already know the video standard used in your geographical area, it's often best to manually select it.

When Video is set to Auto, the projector attempts to pick the video standard (NTSC, NTSC 4.43, PAL, PAL-M, PAL-N, PAL 60 or SECAM) automatically based on the input signal it receives. (The video standard options may vary depending on your region of the world.)

The input signals for SECAM, PAL-M, PAL-N, and PAL 60 video are similar to other video signals and cannot be automatically detected, therefore they must be chosen manually.

If the projector is unable to detect the correct standard, the colors might not look right or the image might appear "torn." If this happens, manually select a video standard.

Highlight **Video standard**, press **menu/select**, use the left or right arrows to cycle through the options, then press **menu/select** to select.

## Image Menu for Computer Sources

To access the Image menu settings, press the **menu/select** button to display the Main menu, press the down arrow to highlight Image, then press **menu/select** again to access the Image menu.

### Resize

**Resize** allows you to select from among four different re-sizing options. The default is **Enhanced Widescreen**, which preserves the aspect ratio of the original theater version and is designed to be used with content that is Enhanced for Widescreen TVs. This option yields more detail than Widescreen Letterbox. **Widescreen Letterbox** also preserves the 16x9 aspect ratio of the original theater version, but the image is placed in a 4x3 space, so black bars appear at the top and bottom of the image. **Standard** resizes the image from its original version to fit a standard 4x3 aspect ratio screen. **Native** displays the image with no resizing.

Highlight **Resize**, press **menu/select**, use the left or right arrow buttons to cycle through the options, then press **menu/select** to select.

### Zoom

This allows you to enter zoom mode without using the remote. Highlight **Zoom**, press **menu/select**, use the left or right arrow buttons to turn zoom mode on, and then press **menu/select**. Exit the menus to use the zoom feature. The zoom icon appears in the lower right corner. Use the **keystone +** button to zoom in and use the **keystone -** button to zoom out. Use the keypad navigation buttons on the keypad to pan the zoomed image. To exit zoom mode, either turn the feature off in the Image menu or press the **zoom mode** button on the remote.

### Auto Image

The projector automatically adjusts tracking, signal synchronization and vertical and horizontal position for most computers. If you want to adjust these features manually, you must turn off **Auto image** first.

Highlight **Auto image**, press **menu/select**, then press the left or right arrow buttons to turn this feature off and on.

## Manual Sync

**NOTE:** The **Manual Sync**, **Manual Tracking**, **Horizontal Position** and **Vertical Position** options are available only for analog computer sources. The projector sets these options automatically for digital computer and video sources, with no manual override.

The projector adjusts signal synchronization automatically for most computers. But if the projected computer image looks fuzzy or streaked, try turning **Auto image** off then back on again. If the image still looks bad, try adjusting the signal synchronization manually:

1. Turn Auto Image off.
2. Highlight Manual sync, press **menu/select**, use the arrow buttons to adjust Manual sync until the image is sharp and free of streaks, then press **menu/select**.

## Manual Tracking

The projector adjusts tracking automatically to match the video signal from your computer. However, if the display shows evenly spaced, fuzzy, vertical lines or if the projected image is too wide or too narrow for the screen, try turning **Auto Image** off then back on again. If the image is still bad, try adjusting the tracking manually:

1. Turn Auto image off.
2. Highlight Manual tracking, press **menu/select**, use the arrow buttons to adjust Manual tracking until the fuzzy vertical bars are gone, then press **menu/select**.

## Horizontal/Vertical Position

Follow these steps to manually adjust the position:

1. Turn Auto image off.
2. Highlight Horizontal position, press **menu/select**, use the arrow buttons to adjust the Horizontal position, then press **menu/select**. Repeat for Vertical position, if necessary.

Positioning adjustments are saved when you turn off the projector.

## Color Management Menu

### Degamma

**NOTE:** Your viewing preferences may vary. Cycle through the degamma options and pick the one you like the best.

Degamma tables contain preset color configurations optimized for the type of source. You can select a degamma table that has been specifically tuned for either computer, video, or film input. Highlight **Degamma**, press **menu/select**, use the left or right arrows to cycle through the options, then press **menu/select** to select.

### Color Space Standard

This option applies to computer and component video sources (it won't appear in the menu for S-video or composite video sources). It allows you to select a color space that has been specifically tuned for your video input. When Auto is selected, the projector automatically determines the standard. Choose RGB for computer sources, choose SMPTE240, REC709, or REC601 for component video sources.

Highlight **Color Space Standard**, press **menu/select**, use the left or right arrows to cycle through the options, then press **menu/select** to select.

### **Auto Color Gain**

When this feature is on, the projector automatically sets the red, green, and blue color gains for each source. When it is off, you can manually adjust the color gains.

### **Red, Green, Blue**

To manually adjust the color gains:

1. Turn Auto Color Gain off.
2. Highlight Red, Green, or Blue, press **menu/select**, use the arrow buttons to adjust the gain, and then press **menu/select**.

### **Control Menu**

To access the Control menu settings, press the **menu/select** button to display the Main menu, press the down arrow to highlight Control, then press **menu/select** again to access the Control menu.

### **Auto Source**

When this feature is on, the projector automatically finds the active source, checking the default source first. When this feature is off, the projector defaults to the source selected in Default Source. To display another source, you must manually select one by pressing the **source** button on the keypad or the **data** or **video** button on the remote.

Highlight **Auto source**; press **menu/select**, then press the left or right arrow buttons to turn this feature off and on.

### **Default Source**

This determines which source the projector checks first for active video during power-up. Select among PC 1-Analog, PC 1-Digital, PC 2-Analog, Video1 S-Video, Video 2-Composite, and Video 3-Component.

Highlight **Default source**, press **menu/select**, and use the left or right arrows to cycle through the options, then press **menu/select** to select.

### **Standby Time**

This option lets you select how long the lamp stays on and the blank screen is displayed when the projector enters standby mode before the projector turns off. Select among 1, 5, 10, 15 and 30 minutes and 1 and 2 hours by clicking the left or right arrow buttons and cycling through the options.

### **Advanced Menu**

#### **Rear Project**

When you turn **Rear Project** on, the projector reverses the image so you can project from behind a translucent screen.

Highlight **Rear Project**, press **menu/select**, then press the left or right arrow buttons to turn this feature off and on.

#### **Ceiling Project**

When you turn **Ceiling Project** on, the projector turns the image upside down for ceiling-mounted projection. Highlight Ceiling Project, press **menu/select**, then press the left or right arrow buttons to turn this feature off and on.

**Display Messages**

This setting toggles between On and Off. When this feature is On, status messages such as “No signal detected” or “Standby Active” appear in the lower-right corner of the screen.

**Display Startup Screen**

This setting toggles between On and Off. When this feature is On, the startup screen appears when the projector starts up and remains until an active source is detected. The startup screen contains contact information. When it is off, a plain blue, black or white screen is displayed instead of the startup screen.

**Reset**

Highlight Reset then press **menu/select** to reset the options in the menus (except Language, Video Standard, Ceiling and Rear Project, Screen Aspect, Video Standard, and Standby Time) to their original settings.

**Language Menu**

You can display the on-screen menus in English, French, German, Spanish, Portuguese, Chinese, Japanese, or Korean.

Press the **menu/select** button to display the Main menu, press the arrow buttons to highlight Language, and then press **menu/select** again to access the Language menu.

Press the arrow buttons to highlight the desired language, and then press **menu/select**. Press **menu/select** to exit this menu and return to the Main menu.

**Status Menu**

This is a read-only menu for informational purposes. To display the Status menu, highlight Status from the Main menu, and then press **menu/select**.

**Lamp Hours Used**

Indicates how many hours the current lamp has been in use. The counter starts at zero hours and counts each hour the lamp is in use. Replace the bulb when the brightness is no longer acceptable. See “Replacing the Projection Lamp” on page 31 for details.

**Video Standard**

Shows the video standard being displayed.

**Computer Resolution (computer sources only)**

Shows the resolution of the computer being displayed.

**Source**

Indicates the active source, PC 1-Analog, PC 1-Digital, PC 2-Analog, PC 2-Component, Video 3-Component HDTV, Video 1 S-Video, Video 2-Composite, and Video 3-Component.

**Software Version**

Indicates the projector’s software version. This information is useful when contacting Technical Support.

## MAINTENANCE & TROUBLESHOOTING

This section describes how to:

- clean the lens
- replace the projection lamp
- clean the projection lamp filter screens
- replace the batteries in the remote
- troubleshoot the projector

### Cleaning the Lens

Follow these steps to clean the projection lens:

1. Apply a non-abrasive camera lens cleaner to a soft, dry cloth.

Avoid using an excessive amount of cleaner, and don't apply the cleaner directly to the lens.

Abrasive cleaners, solvents or other harsh chemicals might scratch the lens.

2. Lightly wipe the cleaning cloth over the lens in a circular motion.
3. If you don't intend to use the projector immediately, replace the lens cap.

### Replacing the Projection Lamp

**WARNING:** To avoid burns, allow the projector to cool for at least 30 minutes before you open the lamp module door. Never extract the lamp module while the projector is operating.

The lamp hour counter in the Status menu counts the number of hours the lamp has been in use. After 1,980 hours of use, the message "Change Lamp" temporarily appears on the screen when the projector is turned on. Change the lamp within the next 20 hours. After 2,000 hours, the lamp will not light. You can order new lamp modules from your Knöll dealer.

Follow these steps to replace the projection lamp:

1. Turn off the projector and unplug the power cord.
2. Wait 30 minutes to allow the projector to cool thoroughly.
3. Invert the projector on a soft flat surface, and then push the ridge on the lamp door toward the back (Figure 39). The arrow on the lamp door should point to the unlock icon on the bottom of the projector. Lift the door up.

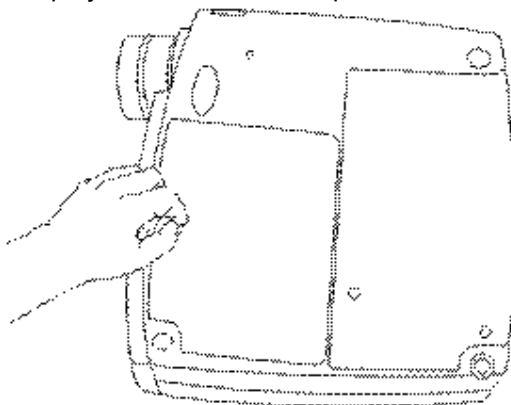

**Figure 39.** Removing the lamp door



**WARNING:** Be extremely careful when removing the lamp module. In the unlikely event that the bulb ruptures, small glass fragments may be generated. The lamp module is designed to contain these fragments, but use caution when removing the lamp module.

4. Loosen the two non-removable screws on the outside of the module (Figure 40).

**CAUTION:** Never operate the projector with the lamp door open or removed. This disrupts the airflow and causes the projector to overheat.

**Figure 40:**

*Loosening the screws on the lamp module*

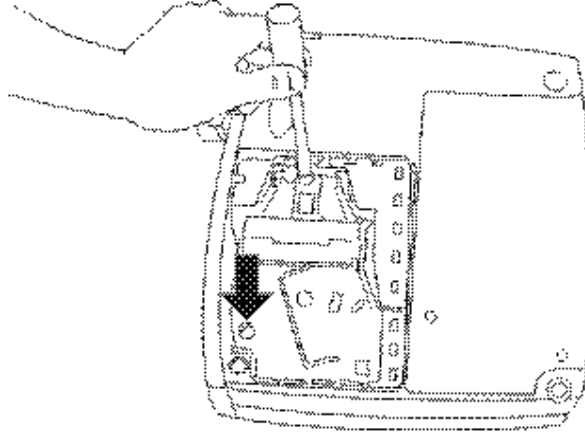

5. Lift and grasp the metal bail wire and lift the module out (Figure 41).  
Dispose of the lamp module in an environmentally proper manner.

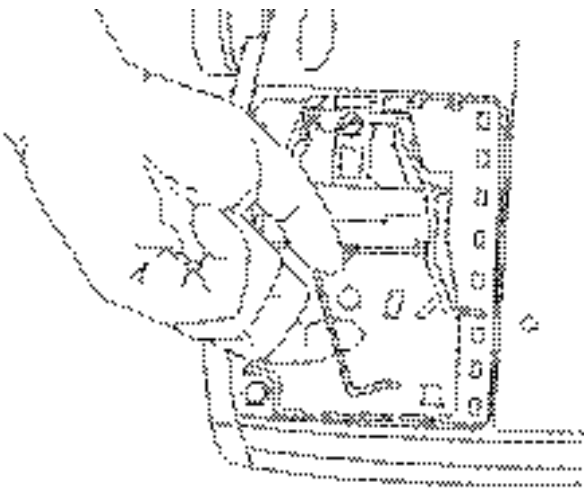

**WARNING:** Do not drop the lamp module or touch the glass bulb! The glass may shatter and cause injury.

**Figure 41:** Removing the lamp module

6. Install the new lamp module, being sure to align the connectors properly.

7. Push the module in until it is flush with the bottom case of the projector.

8. Tighten the screws on the outside of the module.

9. Replace the lamp door by inserting the hooks on the lamp door into the slots on the projector and pressing the lamp door into place. The arrow on the lamp door should point to the lock icon on the bottom of the projector. If the lamp door does not fit properly or bulges out, remove the door and re-seat the lamp module.

10. Plug in the power cord and press the green **power** button to turn the projector back on.

11. To reset the lamp hour counter in the Status window, press and hold the **volume** - button, then press the **source** button (while still holding down the **volume** - button) for 5 seconds. Verify that the counter was reset by viewing the counter in the Status window.

### **Cleaning the Projection Lamp Filter Screens**

In dirty or dusty environments, the dust filter screens on the lamp module can become clogged, causing high temperatures inside the lamp module. These high temperatures can cause premature lamp failure. Routine maintenance to remove dust and dirt from the screens lowers the lamp operating temperature and prolongs lamp life. To maximize lamp life you may want to clean the screen every 250 hours.

1. Remove the lamp module. Refer to “Replacing the Projection Lamp” on page 31 for instructions.
2. Examine the dust filter screens on each side of the lamp module. If necessary, use a vacuum cleaner set on low power to clean the screens. Then use a cotton swab dipped in isopropyl alcohol to lightly wipe each screen. After you've wiped each screen, blow away any remaining contaminants.

**Figure 42:** Lamp module screens

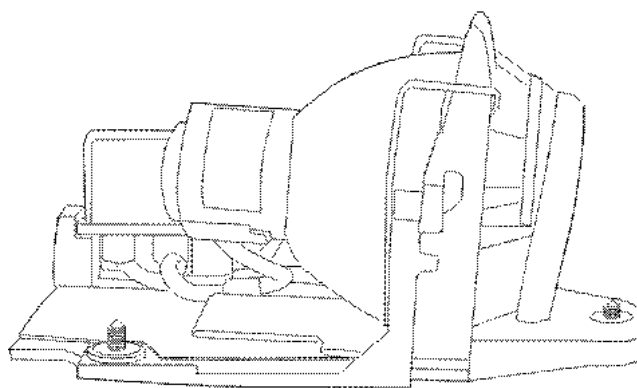

3. Before replacing the lamp, use the vacuum cleaner to clean the lamp housing in the projector.
4. Replace the lamp and lamp door.

### **Replacing the Batteries in the Remote Control**

The life of the batteries depends on how often and how long you use the remote. Symptoms of low battery charge include erratic responses when using the remote and a reduced range of operation.

Follow these steps to replace the batteries:

1. Turn the remote face down in your hand.
2. Push the tab on the battery door toward the top of the remote and lift the door off.
3. Remove the old batteries and dispose of them in an environmentally proper manner.
4. Install two new AAA alkaline batteries. Make sure you install each in the correct direction.
5. Insert the hooks on the battery door into the remote and press the tab to re-install the door.

## Troubleshooting

The LED on top of the projector tells you the state of the projector.

**Table 2: LED behavior and meaning**

<b>LED color/ behavior</b>	<b>Meaning</b>
Solid green	The projector is plugged in, or the projector has been turned on and the software has initialized
Blinking green	The power button has been pressed and the software is initializing
Solid amber	The projector is in standby mode
Blinking amber	The projector is powering down, the fans are running to cool the lamp.
Fast blinking amber	Indicates fan or lamp failure

The following tables list possible symptoms and remedies to situations you may encounter. The first table details potential problems with the projector, the next one with potential problems with a video source, and finally one with potential problems with a computer source.

**Table 3: Problem with the projector**

<b>Symptoms</b>	<b>Remedy</b>
<b>The projector is not running (LED is not lit green)</b>	Make sure that the power cord is properly connected to a fully functional AC electrical outlet. Make sure that the power cord is also properly connected to the projector. If the projector is plugged into a power strip, make sure the power strip is turned on.
<b>The projector is not running (LED is lit green)</b>	Make sure the projector has been turned on by pressing the power button on the remote or keypad.
<b>Projector is running (LED lit green), but nothing appears on projection screens.</b>	Make sure you have removed the lens cap on the projection lens at the front of the projector.
<b>Projector is running (LED blinking series of 3 fast amber), but nothing appears on projection screens.</b>	Check the projector's lamp to ensure that it is securely connected in the lamp module. Make sure the lamp door is installed. Make sure the lamp has not been in use for over 2,000 hours. The lamp automatically shut off at 2,000 hours. See "Replacing the Projection Lamp" page 31.
<b>Only the start-up screen displays</b>	Verify that the cables are connected correctly. Make sure that the cables do not have any bent pins. Verify that the proper input source is connected and selected. See "Source (keypad only) or Data and Video (remote only)" on page 21. If you are watching TV, make sure the projector the projector is connected to a tuner. Attach the source to a TV. If there is no image on the TV, the problem is with the source, not the projector.
<b>No Sounds</b>	Adjust volume on the keypad. Turn off "mute" on the menu. See page 24. Verify audio/input connections. Adjust audio source.
<b>Lamp seems to be getting dimmer</b>	The lamp begins to lose brightness when it has been in use for a long time. Replace the lamp

	as described in “Replacing the Projection Lamp” on page 31.
<b>Lamp shuts off</b>	A minor power surge may cause the lamp to shut off. Unplug the projector, wait at least a minute, then plug it back in. Make sure the vents are not blocked. The lamp screens may be clogged. Avoid smocking around the projector. Clean the screens. See page 33. Make sure the lamp has not been in use for over 2000 hours. The lamp automatically shuts off after 2000 hours. See page 31.

**Table 4: Problem with a video image**

<b>Symptom</b>	<b>Remedy</b>
<b>Image is out of focus</b>	Turn the projection lens to focus the image. Make sure the projection screen is at least 5.6 feet (1.7 m) from the projector. Check the projection lens to see if it needs cleaning
<b>Image isn’t centered on the screen</b>	Move the projector to reposition the image. Adjust the height. Be sure the projector lens is at a 90-degree angle to the screen.
<b>Image is too wide or narrow for the screen</b>	Adjust the zoom or projector placement. Adjust the screen aspect. Adjust the resize option.
<b>Image is not square</b>	Adjust the keystone
<b>Image is noisy</b>	Turn overscan on
<b>Color or text not being projected</b>	You might need to adjust the brightness up or down until the text is visible. Refer to “Brightness” on page 23 for more information.
<b>Image and menus are reversed left to right</b>	Rear projection mode is probably turned on. Turn Rear Projection off in the Controls menu. The image should immediately return to forward projection. See “Rear Project” on page 29.
<b>Image and menus are upside down</b>	Ceiling mode is probably turned on. Turn Ceiling off in the Controls menu. See “Ceiling Project” on page 29.
<b>Projected colors don’t match the video device’s color</b>	Adjust the brightness, tint and/or contrast from the Display menu. See “Brightness” on page 36, “Tint” on page 24 and “Contrast” on page 23. Adjust the color space. See page 28.
<b>Colors are washed out or too deep</b>	Try selecting another Gamma setting. See page 28.
<b>Image from component source appears “greenish”</b>	Try selecting another color space setting. If the source is 1080i, select “smpte240”. If the source is 720p, select “rec709”. If the source is 480p, select “rec601”. See page 28.
<b>Image appears “torn”</b>	The wrong video standard may be selected. See “Video Standard” on page 27.

**Table 5: Problem with a computer image**

<b>Symptom</b>	<b>Remedy</b>
<b>Only the start-up screen displays</b>	<p>Verify that the cables are connected correctly. Make sure the cables don't have any bent pins. Verify that the proper input source is connected and selected. See "Source (keypad only) or Data and Video (remote only)" on page 21. You might need to turn everything off and power up the equipment again in the proper order. Refer to your computer's documentation to determine the correct order.</p> <p>Make sure your laptop's external video port is turned on. See your computer's manual for details.</p> <p>Make sure your computer's video board is installed and configured correctly. If you're using Windows 98, Open "My Computer" icon, the Control Panel folder and then the Display icon. Click the Settings tab. Verify that the Desktop area is set to 1024x768 or less.</p>
<b>Image isn't centered on the screen</b>	<p>Move the projector to reposition the image. Adjust the height.</p> <p>Be sure the projector is at a 90-degree angle to the screen.</p> <p>Reposition the image using the menu. Refer to "Horizontal/Vertical Position" on page 28.</p>
<b>The screen resolution is not right</b>	<p>Make sure the computer's video card is set for a resolution of no greater than 1280x1024.</p>
<b>Image is "noisy" or streaked</b>	<p>Try these steps in this order.</p> <p>Deactivate the screen saver on your computer.</p> <p>Turn <b>Auto Image</b> off and then back on again. See "Auto Image" on page 27.</p> <p>Turn <b>Auto Image</b> off and adjust the synchronization and tracking manually to find an optimal setting. See "Manual Sync" on page 28 and "Manual Tracking" on page 28.</p> <p>The problem could be with your computer's video card. If possible, connect a different computer.</p>
<b>Projected colors don't match the computer or video player colors</b>	<p>Just as there are differences in the displays of different monitors, there are often differences between the computer image and the projected image. Adjust the brightness, tint and/or contrast from the Display menu. See "Brightness" on page 23, "Tint" on page 24 and "Contrast" on page 23.</p>
<b>Image appears "purplish"</b>	<p>Try selecting RGB as the color space setting. See page 28.</p>

## Appendix

### Specifications

The projector must be operated and stored within the temperature and humidity ranges specified.

#### Temperature

---

Operating	50 to 104° F (10 to 40° C) at sea level 50 to 95° F (10 to 35° C) at 10 000 feet
Non-operating	-4 to 158° F (-20 to 70° C)

#### Altitude

---

Operating	0 to 10 000 feet (3000 m)
Non-operating	0 to 20 000 feet (6100 m)

#### Humidity

---

Operating and Non-op 10% to 95% relative humidity, non-condensing

#### Dimensions

---

10.4 x 11.1 x 3.3 inches (264 x 283 x 85 mm)  
with module 10.4 x 12.1 x 3.3 (264 x 307 x 85 mm)

#### Weight

---

6.1 lbs (2.8 kg) unpacked, with module 6.7 lbs. (3.0 kg)

#### Lamp

---

220-watt SHP lamp model SP-LAMP-002

## A

- adjusting
  - brightness 23
  - color 24
  - color gain 28
  - contrast 23
  - height of the projector 20
  - keystone 23
  - tint 24
  - volume 24
- Advanced menu options
  - Ceiling Project 29
  - Display Messages 30
  - Display Startup Screen 30
  - Rear Project 29
  - Reset 30
- altitude limits 37
- aspect ratio 10
- audio cable, connecting 11, 13, 15, 17, 18
- Audio menu options
  - Mute 24
  - Volume 24
- Auto color gain 28
- auto image 27
- auto source 29

## B

- batteries
  - installing 33
  - type 33
- Blank Screen 24
- brightness, adjusting 23
- buttons on keypad
  - Keystone 23
  - Menu/select 21
  - Power 22
  - Source 21
  - Standby 22
  - Volume 22

## C

- cable box 9, 11
- cables
  - audio 11, 13, 15, 18
  - computer cable 2, 18
- camcorder, connecting 17
- ceiling projection 29
- centering the image 20, 27
- cleaning lamp filter screens 33
- cleaning the projection lens 31
- color gain, adjusting 29
- Color Management menu options
  - Auto color gain 29
  - Color Space Standard 28
  - Degamma 28
- Color Space Standard 28
- colors
  - adjusting 24
  - not displayed 35
- compatibility
  - IBM-compatible 5
  - Macintosh 5
  - video devices 5
- computers
  - compatible 5
  - connecting 18
- connecting
  - audio cable 11, 13, 15, 18
  - camcorder 17
  - computers 18
  - DVD or VHS tape players 13
  - power cord 11, 14, 16, 18
  - television tuner 11
  - video device 9

- video game 17
- connectors on module 8, 10
- contrast, adjusting 23
- Control menu options
  - Auto source 29
  - Default Source 29
  - Standby Time 29

## D

- Default Source 29
- Degamma 28
- Display menu options
  - Blank screen 24
  - Brightness 23
  - Color 24
  - Contrast 23
  - Keystone 23
  - Screen Aspect 24
  - Sharpness 24
  - Tint 24
- Display Messages 29
- Display Startup Screen 29
- displaying on-screen menus 21
- Dual Mode DMD 5
- DVDs, playing 13

## E

- elevator button/foot 20
- Enhanced Connectivity Module
  - attaching to the projector 9
- Enhanced Widescreen 25

## F

- focusing the image 20
- forward/back buttons 21
- fuzzy lines 28

## H

- HDTV 5, 15, 24
- height adjustment 20
- Horizontal Position 28

## I

- IBM-compatible computers 5
- image
  - adjusting 18, 20
  - centering 28
  - focusing 20
  - fuzzy lines 28
  - offset 8
  - resolution 5
  - reversed 29
  - size 8
  - squaring 22
  - zooming 20
- Image menu options
  - Auto Image 27
  - Horizontal/Vertical Position 28
  - Manual Sync 28
  - Manual Tracking 28
  - Overscan 26
  - Resize 25,27
  - Video Standard 26
  - Zoom 26, 27
- image offset 8

## K

- keypad 21
- keystone 22

## L

- lamp
  - cleaning filter screens 33
  - replacing 31
- lamp hour counter 30, 31, 32
- Language menu 30
- language, selecting for menus 30
- laptop computers
  - compatibility 18
  - connecting 18
- LED 21, 22, 34
- LED behavior 34
- lens cleaning 31
- letterbox 26

## M

- Macintosh computers
  - compatibility 5
- maintenance 31
- Manual Synch 28
- Manual Tracking 28
- menus. See on-screen menus
- mute 24

## N

- Native resize option 26
- NTSC video 27

## O

- on-screen menus
  - changing language of 30
  - displaying 23
- overscan 26

## P

- PAL video 27
- playing a video game 17
- Power button 12, 14, 16, 18, 21
- power cord connecting 12, 14, 16, 18
- power up sequence 19,36
- PowerPoint slides, advancing
  - with the remote 21
- project from behind the screen 29
- project from the ceiling 29
- projection distance 8
- projector
  - connecting video devices 9
  - positioning 8
  - project from behind the screen 29
  - setting up 8
  - specifications 37
  - troubleshooting problems 34
  - turning off 17, 19
  - turning on 18

## R

- rear projection 29
- remote control
  - advancing PowerPoint slides with 21
  - replacing the batteries 33
  - using 21
- replacing projection lamp 31
- re-positioning the image on the screen 27
- resetting adjustments 30
- resetting the lamp hour counter 32
- Resize options 26
- resizing the image 25
- RS-232 control 9

**S**

safety guidelines 3  
 Screen Aspect 9, 24  
 SECAM video 27  
 sharpness 24  
 Source button 21  
 specifications 37  
 squaring the image 21  
 Standard resize option 26  
 standby 17, 19, 22  
 standby time 29  
 Status menu 30

**T**

temperature limits 37  
 tint, adjusting 24  
 troubleshooting 34  
 turning off the projector 17, 19  
 turning on the projector 18  
 TV tuner 9  
 TV, watching 11

**V**

vertical lines displayed 28  
 Vertical Position 28  
 VHS tapes, playing 13  
 video game, connecting 17  
 video players/VCRs 13

video standards 26  
 Volume buttons 22  
 volume, adjusting 22, 24

**W**

warranty 39  
 watching a DVD or VHS tape 13  
 watching HDTV 15  
 watching regular TV 11  
 Widescreen letterbox 26

**Z**

Zoom mode 22  
 zooming the image 20, 22, 27

**LIMITED WARRANTY**

Knöll Systems, Inc. (“Knöll”) warrants that each HD110 (“the Product”) sold hereunder will conform to and function in accordance with the written specifications of Knöll. Said limited warranty shall apply only to the first person or entity that purchases the Product for personal or business use and not for the purpose of distribution or resale. Said warranty shall continue for a period of two (2) years from the date of such purchase. The standard limited warranty excludes the lamps in projectors after 90 days and the accessories after one year. Knöll does not warrant that the Product will meet the specific requirements of the first person or entity that purchases the Product for personal or business use. Knöll’ liability for the breach of the foregoing limited warranty is limited to the repair or replacement of the Product or refund of the purchase price of the Product, at Knöll’ sole option. Replacement Product may be refurbished in “like-new” condition, at Knöll’ sole discretion. To exercise the Purchaser’s rights under the foregoing warranty, the Product must be returned at the Purchaser’s sole cost and expense, to Knöll or to any authorized Knöll service center provided, and the Product must be accompanied by a written letter explaining the problem and which includes (i) proof of date of purchase; (ii) the dealer’s name; and (iii) the model and serial number of the Product. When sending your unit in for repair, please ship your unit in its original packing material or a Knöll approved ATA Shipping Case, or have a professional packaging company pack the unit. Please insure your shipment for its full value. A return authorization number, issued by the Knöll customer service department, must also be clearly displayed on the outside of the shipping carton containing the Product.

Note: Remanufactured Products are exempt from the foregoing Limited Warranty. Please refer to the Remanufactured Product Warranty for applicable warranty information.

**WARRANTY LIMITATION AND EXCLUSION**

Knöll shall have no further obligation under the foregoing limited warranty if the Product has been damaged due to abuse, misuse, neglect, accident, unusual physical or electrical stress, unauthorized modifications, tampering, alterations, or service other than by Knöll or its authorized agents, causes other than from ordinary use or failure to properly use the Product in the application for which said Product is intended.

**DISCLAIMER OF UNSTATED WARRANTIES**

THE WARRANTY PRINTED ABOVE IS THE ONLY WARRANTY APPLICABLE TO THIS PURCHASE. ALL OTHER WARRANTIES, EXPRESS OR IMPLIED, INCLUDING, BUT NOT LIMITED TO, THE IMPLIED WARRANTIES OF MERCHANTABILITY AND FITNESS FOR A PARTICULAR PURPOSE ARE DISCLAIMED. THERE ARE NO WARRANTIES THAT EXTEND BEYOND THE FACE HEREOF AND THE FOREGOING WARRANTY SHALL NOT BE EXTENDED, ALTERED OR VARIED EXCEPT BY WRITTEN INSTRUMENT SIGNED BY KNÖLL. SOME STATES DO NOT ALLOW LIMITATIONS ON HOW LONG AN IMPLIED WARRANTY MAY LAST, SO SUCH LIMITATIONS MAY NOT APPLY TO YOU.

**LIMITATION OF LIABILITY**

IT IS UNDERSTOOD AND AGREED THAT KNÖLL’ LIABILITY WHETHER IN CONTRACT, IN TORT, UNDER ANY WARRANTY, IN NEGLIGENCE OR OTHERWISE SHALL NOT EXCEED THE RETURN OF THE AMOUNT OF THE PURCHASE PRICE PAID BY PURCHASER AND UNDER NO CIRCUMSTANCES SHALL KNÖLL BE LIABLE FOR SPECIAL, INDIRECT, INCIDENTAL OR CONSEQUENTIAL DAMAGES OR LOST PROFITS, LOST REVENUES OR LOST SAVINGS. THE PRICE STATED FOR THE PRODUCT IS A CONSIDERATION IN LIMITING KNÖLL’ LIABILITY. NO ACTION, REGARDLESS OF FORM, ARISING OUT OF THE AGREEMENT TO PURCHASE THE PRODUCT MAY BE BROUGHT BY PURCHASER MORE THAN ONE YEAR AFTER THE CAUSE OF ACTION HAS ACCRUED. SOME STATES DO NOT ALLOW THE EXCLUSION OR LIMITATION OF INCIDENTAL OR CONSEQUENTIAL DAMAGES SO THE ABOVE LIMITATION OR EXCLUSION MAY NOT APPLY TO YOU. THIS LIMITED WARRANTY GIVES YOU SPECIFIC LEGAL RIGHTS, AND YOU MAY ALSO HAVE OTHER RIGHT WHICH VARIES FROM STATE TO STATE.



## Viewing the HD110 Projector

Depending on what is viewed the most the user must decide if a 4:3 (1.33:1) or 16:9 (1.85:1) aspect ratio screen is best. Both screen aspect screens will display all images, but the highest resolution images are obtained when viewing the image in its correct aspect ratio screen. If the image is projected on a large wall (not recommended but white color preferred) then all combinations are possible.

### Viewing the HD110 on a 16:9 Screen

1. On the ⇒**DISPLAY** menu select ⇒**16:9**. With a 16:9 screen the 4:3 selection is never used.
2. Viewing a 16:9 image (most DVD movies and HDTV's). Turn the source on and while an image is displaying, select:  
⇒**IMAGE** ⇒**RESIZE** ⇒**WIDESCREEN LETTERBOX**  
This mode will display most DVD movies and HDTV sources. If the image is distorted (short and fat images) try selecting the anamorphic mode:  
⇒**IMAGE** ⇒**RESIZE** ⇒**ENHANCED WIDESCREEN**  
Note: Many movies and other sources are recorded in wider aspect ratios (most common are 2.35:1 and 2.15:1) than 1.85:1 so even in the two widescreen modes above, the image may have uneven black boxes on the top and bottom of the image.
3. Viewing a 4:3 image (most regular cable TV channels and VHS). Turn the source on and while an image is displaying, select:  
⇒**IMAGE** ⇒**RESIZE** ⇒**STANDARD**  
In this mode there will always be black boxes to the image left and right.
4. ⇒**IMAGE** ⇒**RESIZE** ⇒**NATIVE** is not normally used to view video.

### Viewing the HD110 on a 4:3 Screen

1. On the ⇒**DISPLAY** menu select ⇒**4:3**. With a 4:3 screen the 16:9 selection is never used.
2. Viewing a 4:3 image (most regular cable TV channels and VHS). Turn the source on and while an image is displaying, select:  
⇒**IMAGE** ⇒**RESIZE** ⇒**STANDARD**
3. Viewing a 16:9 image (most DVD movies and HDTV's). Turn the source on and while an image is displaying, select:  
⇒**IMAGE** ⇒**RESIZE** ⇒**WIDESCREEN LETTERBOX**  
This mode will display most DVD movies and HDTV sources. In widescreen letterbox there will always be black boxes on the top and the bottom of the image. If the image is distorted (tall and skinny images) try selecting the anamorphic mode:  
⇒**IMAGE** ⇒**RESIZE** ⇒**ENHANCED WIDESCREEN**  
Note: Many movies and other sources are recorded in wider aspect ratios (most common are 2.35:1 and 2.15:1) than 1.85:1 so even in the two widescreen modes above, the image will have different size uneven black boxes on the top and bottom of the image.
4. ⇒**IMAGE** ⇒**RESIZE** ⇒**NATIVE** is not normally used to view video.

