

**EPSON® PowerLite® 7850p  
Multimedia Projector**

*User's Guide*

## Important Safety Information

*WARNING:* Never look into the projector lens when the lamp is turned on; the bright light can damage your eyes. Never let children look into the lens when it is on. Never open any cover on the projector, except the lamp and filter covers. Dangerous electrical voltages inside the projector can severely injure you. Except as specifically explained in this *User's Guide*, do not attempt to service this product yourself. Refer all servicing to qualified service personnel.

*WARNING:* The projector and its accessories come packaged in plastic bags. Keep plastic bags away from small children to avoid any risk of suffocation.

*Caution:* When you replace the lamp, never touch the new lamp with your bare hands; the invisible residue left by the oil on your hands may shorten the lamp life. Use a cloth or glove to handle the new lamp.

## Copyright Notice

All rights reserved. No part of this publication may be reproduced, stored in a retrieval system, or transmitted in any form or by any means, electronic, mechanical, photocopying, recording, or otherwise, without the prior written permission of SEIKO EPSON CORPORATION. The information contained herein is designed only for use with this EPSON product. EPSON is not responsible for any use of this information as applied to other products.

Neither SEIKO EPSON CORPORATION nor its affiliates shall be liable to the purchaser of this product or third parties for damages, losses, costs, or expenses incurred by purchaser or third parties as a result of: accident, misuse, or abuse of this product or unauthorized modifications, repairs, or alterations to this product, or (excluding the U.S.) failure to strictly comply with SEIKO EPSON CORPORATION's operating and maintenance instructions.

SEIKO EPSON CORPORATION shall not be liable for any damages or problems arising from the use of any options or any consumable products other than those designated as Original EPSON Products or EPSON Approved Products by SEIKO EPSON CORPORATION.

EPSON is a registered trademark, and EasyManagement, EasyMP, Quick Corner, and Wall Shot are trademarks of SEIKO EPSON CORPORATION.

EPSON Connection, EPSON Store, and Extra Care are service marks; SizeWise is a trademark; and PrivateLine, Presenters Club, and PowerLite are registered trademarks of Epson America, Inc.

Pixelworks, DNX, and the DNX logo are trademarks of Pixelworks, Inc.

General Notice: Other product names used herein are for identification purposes only and may be trademarks of their respective owners. EPSON disclaims any and all rights in those marks.

# C

## *Contents*

<i>Welcome</i> .....	9
Using Your Documentation .....	10
Getting More Information .....	10
Registration and Warranty .....	11
Unpacking the Projector .....	12
Additional Components .....	13
Optional Accessories .....	14

## 1

<i>Displaying and Adjusting the Image</i> .....	15
Positioning the Projector .....	16
Projecting the Image .....	18
Turning on the Projector .....	18
Selecting the Image Source .....	20
Troubleshooting Display Problems .....	21
You Can't Project an Image .....	21
The Projector and Laptop Don't Display the Same Image .....	21
Adjusting the Image .....	24
Focusing and Zooming Your Image .....	24
Adjusting the Height of Your Image .....	25
Adjusting the Image Shape .....	26
Correcting Computer Images .....	28
Shutting Down the Projector .....	29

## 2

<i>Using the Remote Control</i> .....	31
Activating and Using the Remote Control .....	32
Using the Navigation Buttons .....	33
Replacing the Batteries .....	34

Controlling the Picture and Sound . . . . .	35
Switching Between Picture Sources . . . . .	35
Previewing Picture Sources . . . . .	36
Adjusting the Image Shape . . . . .	37
Turning Off the Picture and Sound . . . . .	38
Stopping Action . . . . .	38
Zooming Your Image . . . . .	39
Displaying a Picture-in-Picture Video . . . . .	39
Controlling the Volume . . . . .	40
Highlighting Your Presentation . . . . .	41
Using the Pointer Tool . . . . .	41
Customizing the Pointer Tools . . . . .	42
Projecting Images Without a Screen . . . . .	43
Making Initial Color Corrections . . . . .	43
Adjusting Color Corrections for a New Surface . . . . .	44
Operating Your Computer with the Remote Control . . . . .	44
Enabling Password Protection . . . . .	45
Starting the Projector with a Password . . . . .	47

### 3

### *Connecting to Computers, Cameras, and Other Equipment.* . . . . .

Connecting to a Computer . . . . .	50
Connecting to the Computer Port . . . . .	51
Connecting to the BNC Connectors . . . . .	53
Connecting to the DVI Port . . . . .	54
Using the Macintosh Desktop Adapter . . . . .	55
Connecting the Cable for Remote Mouse Control . . . . .	56
Connecting an External Monitor . . . . .	57
Connecting to Video Equipment . . . . .	58
Connecting a Composite Video Source . . . . .	59
Connecting an S-Video Source . . . . .	60
Connecting a Component Video Source . . . . .	61
Connecting an RGB Video Source . . . . .	62
Connecting to a Digital Camera . . . . .	64
Removing the USB Cable . . . . .	64

Playing Sound Through the Projector. . . . .	65
Connecting Audio Equipment to the Projector . . . . .	65
Connecting External Speakers . . . . .	66

## 4

<i>Presenting Through a Wireless Network</i> . . . . .	67
Starting EasyMP. . . . .	68
Configuring the Connection. . . . .	70
Using Ad Hoc Mode . . . . .	70
Using Access Point Mode . . . . .	77
Projecting Wirelessly. . . . .	89
Using the Control Bar . . . . .	94
Connecting in IP Connect Mode. . . . .	95
Switching Between Users . . . . .	98
Removing the Wireless 802.11b Card. . . . .	99

## 5

<i>Presenting from a Memory Card or Digital Camera</i> . . . . .	101
Creating a Scenario . . . . .	102
Converting a PowerPoint File to a Scenario . . . . .	102
Creating a Scenario from Scratch . . . . .	104
Transferring Your Scenario to a Memory Card. . . . .	111
Inserting the Memory Card in the Projector. . . . .	113
Removing the Card . . . . .	114
Presenting Scenarios . . . . .	115
Controlling Your Presentation . . . . .	116
Editing Your Scenario on the Projector . . . . .	116
Creating a Slideshow on the Fly . . . . .	118
Displaying the Slideshow . . . . .	118
Changing Timing and Other Settings . . . . .	119
Presenting Image Files on Your Digital Camera . . . . .	120

# 6

<i>Using the Projector's Menu</i> .....	123
Using the Menu System .....	124
Restoring the Default Settings .....	125
Adjusting the Image Quality .....	126
Adjusting Images from Video Sources .....	126
Adjusting Computer Images .....	127
Adjusting the Image Size, Shape, and Position .....	129
Adjusting the Color .....	130
Adjusting the Sound .....	131
Creating Your Own Startup Screen .....	132
Capturing the Image .....	132
Choosing When to Display the Image .....	134
Controlling Multiple Projectors .....	135
Setting the Projector ID .....	135
Changing the Remote Control ID .....	136
Customizing Projector Features .....	137
Image Setup Options .....	137
Remote Monitoring Setup Options .....	138
Miscellaneous Setup Options .....	139

# 7

<i>Managing Projectors</i> .....	141
Connecting and Configuring the Projector	
on a Wired Network .....	142
Using EMP Monitor .....	144
Opening and Closing EMP Monitor .....	144
Registering a Projector .....	145
Monitoring Your Projectors .....	147
Controlling Your Projectors .....	149
Configuring the Monitoring Interval .....	151
Using E-mail Alerts .....	152
Understanding the Notification Messages .....	155
Using a Browser to Monitor Projectors .....	156

Using Projector Groups . . . . .	158
Creating a Group . . . . .	158
Connecting to a Projector in a Group . . . . .	161
Exporting a Projector Group . . . . .	163
Importing a Projector Group . . . . .	165

## 8

<i>Maintaining the Projector</i> . . . . .	167
Cleaning the Lens . . . . .	168
Cleaning the Projector Case . . . . .	168
Cleaning the Air Filters and Vents . . . . .	169
Replacing the Lamp and Air Filters . . . . .	170
Resetting the Lamp Timer . . . . .	173
Transporting the Projector . . . . .	174

## 9

<i>Solving Problems</i> . . . . .	175
Using On-Screen Help . . . . .	176
Checking Projector Status . . . . .	177
What To Do When the Lights Flash . . . . .	177
Viewing Lamp Usage and Other Information . . . . .	179
Solving Problems with the Image or Sound . . . . .	180
Solving EasyManagement Problems . . . . .	186
Solving Problems with the Remote Control . . . . .	190
Where To Get Help . . . . .	191
Telephone Support Services . . . . .	191

<b>A</b>	<i>Software Installation</i> . . . . .	193
	Windows System Requirements . . . . .	193
	Macintosh System Requirements . . . . .	194
	Installing the Software on a Windows System . . . . .	195
	Installing the Software on a Macintosh. . . . .	196
<b>B</b>	<i>Projector Installation</i> . . . . .	199
	Installation Guidelines . . . . .	199
<b>C</b>	<i>Technical Specifications</i> . . . . .	201
<b>D</b>	<i>Notices</i> . . . . .	207
	Important Safety Instructions . . . . .	207
	Remote Control Information . . . . .	209
	Declaration of Conformity . . . . .	210
	FCC Compliance Statement. . . . .	211
	Warranty . . . . .	212
	<i>Index</i> . . . . .	215



# W *Welcome*

The EPSON® PowerLite® 7850p is an easy-to-use, lightweight projector that offers up to 3500 lumens of brightness and a 700:1 contrast ratio for incredibly vivid images and clear text.

## **Versatility**

You can connect it to a wide range of computers and video sources, or you can project over an 802.11b wireless network or a wired LAN network. You can even store your presentation on a memory card for a computer-free presentation.

## **Ease of use**

The projector's keystone correction feature automatically corrects image distortion, and EPSON's unique Wall Shot™ function lets you project against blackboards and colored walls without loss of image color, regardless of ambient lighting. If space is limited, you can project against a surface less than two and one-half feet away.

## **Complete control**

Use the remote control to take charge of your presentation. Freeze the action, zoom in on part of the picture, or display a picture-in-picture video. Use the remote as a pointer, or to draw on the screen. You can even use it in place of your computer's mouse to control your computer and change slides in Microsoft® PowerPoint®.

## **EasyManagement™**

With the projector's EasyManagement system, you can use a Windows® PC to remotely monitor and control the projector over a network.

## **Security**

To prevent unauthorized use, you can assign the projector a password, thus preventing unauthorized persons from using it.

---

## Using Your Documentation

This book contains all the information you need to set up and use your projector. Please follow these guidelines as you read through it:

- Warnings must be followed carefully to avoid bodily injury.
- Cautions must be observed to avoid damage to your equipment.
- Notes contain important information about your projector.
- Tips contain additional projection hints.

## Getting More Information

Need tips on giving presentations? Quick steps for setting up your projector? Here's where you can look for help:

- **presentersonline.com**  
Includes a library of articles covering presentation tips, tricks, and technology. The site provides templates, clip art and sound clips, as well as Presenters Services to use on the road. Even more resources and services are available if you register to join the Presenters Club®—and it's free.
- **Quick Setup sheet**  
Gives you the instructions you need to get your projector up and running if you are connecting to a laptop, PowerBook®, or iBook® computer.
- **Start Here kit**  
Includes this *User's Guide*, your *Quick Setup* sheet, warranty brochures, and EPSON PrivateLine® Support card. Keep the folder with your projector at all times.
- **Built-in help system**  
Provides assistance for common problems. Available from the **Help** button on the projector or the remote control. See page 176 for details.
- **support.epson.com**  
Download FAQs and e-mail your questions to EPSON support.

---

### need help?

If you still need help after checking this User's Guide and the sources listed to the right, you can use the EPSON PrivateLine Support service to get help fast. Call (800) 637-7661 and enter the PIN on the card in your Start Here kit. Or take advantage of EPSON's automated support services 24 hours a day. See page 191 for more information.

---

## *Registration and Warranty*

Your projector comes with a basic carry-in warranty as well as an international warranty that let you project with confidence anywhere in the world. For details, see page 212 and the warranty brochure included in your *Start Here* kit.

In addition, for customers who register their projector, EPSON offers free Extra Care<sup>SM</sup> Road Service. In the unlikely event of an equipment failure, you won't have to wait for your unit to be repaired. Instead, EPSON will ship you a replacement unit anywhere in the United States or Canada, usually via overnight delivery. See the brochure in your Start Here kit for details.

To register, simply fill out the registration card included in your *Start Here* kit and mail it to EPSON. Or you can register online at <http://epsonwebreg.info2.net/>. Registering also lets you receive special updates on new accessories, products, and service.

## Unpacking the Projector

After unpacking the projector, make sure you have all the parts shown below:

### **note**

*You won't need all these components; your configuration will determine which ones you need.*

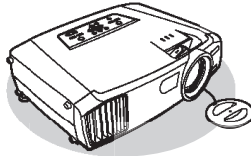

Projector



Remote control and batteries

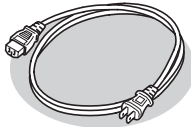

Power cable

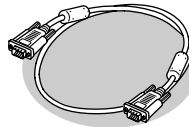

VGA computer cable

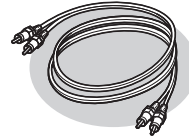

RCA-style audio cable

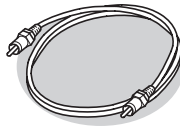

RCA-style video cable



Stereo mini-jack audio cable

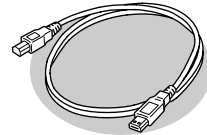

USB cable



802.11b wireless card



Projector software  
CD-ROM

Save all packaging in case you need to ship the projector. Always use the original packaging (or the equivalent) when you need to send the projector to another location. If you are moving the projector by hand, use a carrying case (either an EPSON case or something similar, such as a laptop case). See page 14 for ordering information, and page 174 for transportation instructions.

## ***Additional Components***

Depending on how you plan to use the projector, you may need additional components:

- To receive an S-video signal, you'll need an S-video cable. One may be provided with your video equipment, or you can purchase one from EPSON; see page 14.
- To receive a component video signal from a VCR or other video device, you'll need a component video cable.
- Some older PowerBooks® and Macintosh® desktop models may need the Macintosh desktop adapter set shown on page 55 (available from EPSON; see page 14.) Older iMac® systems may need a special adapter to provide a VGA output port; see your computer dealer.

## Optional Accessories

To enhance your use of the projector, EPSON provides the following optional accessories:

Product	Part number
Replacement lamp and air filters	V13H010L22
Air filter replacement set	V13H134A01
ATA molded hardshell case ATA shipping case	ELPKS48 ELPKS46
Ceiling mount Suspension adapter False ceiling plate	ELPMB40 ELPMBAPL ELPMBFCP
Middle Throw Zoom Lens Long Throw Zoom Lens	V12H004M03 V12H004L05
Kensington® security lock	ELPSL01
Projection screens: 50-inch portable screen 60-inch portable pop-up screen 80-inch portable pop-up screen	ELPSC06 ELPSC07 ELPSC08
Macintosh adapter set (includes monitor adapter and desktop adapter)	ELPAP01
Remote control cable set	V12H005C28
DVI to DVI digital video cable, 10 ft. DVI to DFP digital video cable, 10 ft. Component video cable, 10 ft. S-video cable	V12H005C20 V12H005C21 ELPKC19 ELPSV01
Distribution amplifier	ELPDA01
High resolution document imager High resolution document camera Motion presentation camera	ELPDC02 V12H064020 ELPDC03

You can purchase these accessories from your dealer, by calling EPSON at (800) 873-7766, or by visiting the EPSON Store<sup>SM</sup> at [www.epsonstore.com](http://www.epsonstore.com) (U.S. sales only). In Canada, please call (800) 463-7766 for dealer referral.

# 1 *Displaying and Adjusting the Image*

Whether you're presenting from a computer or video equipment, you need to follow some basic steps to display your image on the screen.

Follow the guidelines in this chapter for:

- Positioning the projector
- Turning the projector on and selecting the image source
- Troubleshooting display problems
- Adjusting the image
- Turning off the projector

## note

You can mount the projector on the ceiling, or place it behind a translucent screen for rear projection. See Appendix B for details.

## Positioning the Projector

If you're setting up the projector yourself and it isn't already installed in the theater or conference room you're using, you'll probably want to place it on a table in front of the screen, as shown.

This lets you stand in the front of the room, face the audience, and remain close enough to the equipment to be able to control it. Try to leave as much space as possible between the projector and the screen to get a good-size image.

Use the figure below to help you determine placement. Image size increases with distance, but can vary depending on how you position the zoom ring and whether you've adjusted the image with other settings.

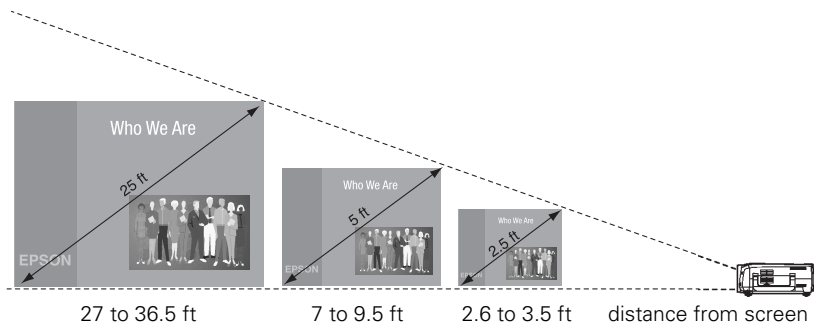

Also keep these considerations in mind:

- Place the projector on a sturdy, level surface.
- Make sure there is plenty of space for ventilation around and under the projector. Do not set the projector on top of loose papers that could block the vents under the projector.
- Make sure the projector is within 10 feet of a grounded electrical outlet or extension cord.



Ideally, you should place the projector directly in front of the center of the screen, facing it toward the screen squarely. The base of the lens should be at about the level of the bottom of the screen.

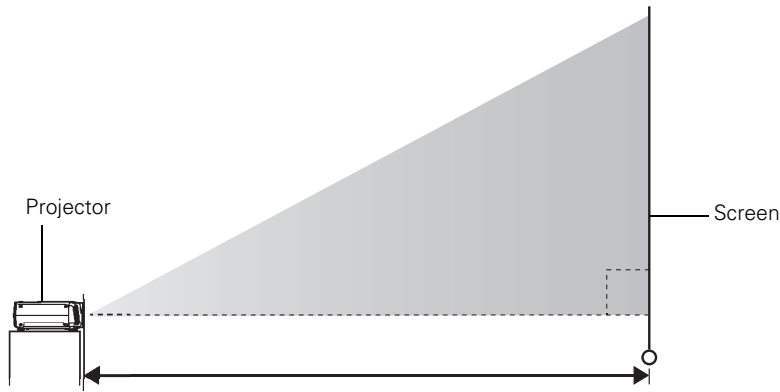

If you place the projector below screen level, you'll have to tilt it up by extending its feet. This causes the image to become “keystone” shaped, but you can correct the distortion by pressing the **Sync** buttons on the projector. See page 26 for detailed information about correcting the image shape.

For instructions on installing the projector in a permanent location, such as a theater or conference room, see Appendix B.

---

**note**

*After positioning the projector, you may want to connect a Kensington MicroSaver® anti-theft device to the lock port on the projector's left side. You can purchase this from EPSON; see “Optional Accessories” on page 14.*

---

## Projecting the Image

Make sure your projector and other equipment are set up as described in Chapter 3. Then follow the instructions below to start the projector and display an image.

### **note**

*To shut down the projector, see page 29. Shutting down the projector correctly prevents premature lamp failure and possible damage from overheating.*

### **Turning on the Projector**

If you turn on any connected computer or video equipment before starting the projector, this lets the projector automatically detect and display the image source. If you turn on the projector first, or have multiple pieces of connected equipment, you may have to select the image source manually (see page 20).

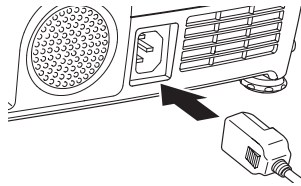

Follow these steps to turn on the projector:

1. Remove the lens cap.
2. Plug one end of the power cable into the projector, and the other end into a grounded electrical outlet.



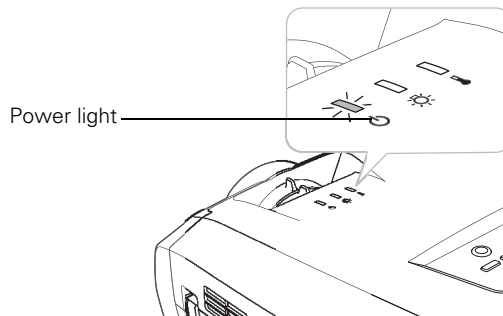

3. Wait until the  power light stops flashing and turns orange.

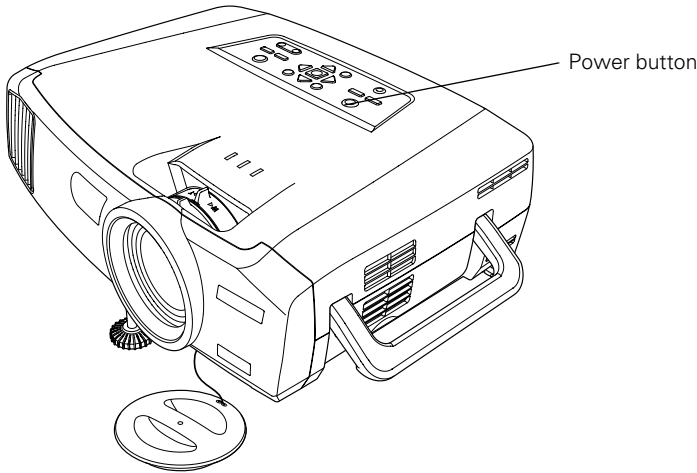
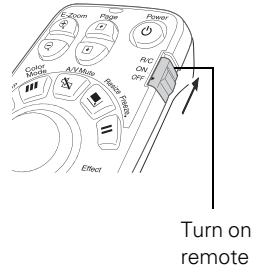

4. Press the red  Power button on top of the projector—or press the  Power button on the remote control.

(If this is your first time using the remote control, make sure the batteries are installed and the ON/OFF switch on the side of the remote is turned on.)



The  power light flashes green as the projector warms up, and an image begins to appear. When the  power light stops flashing and remains green (in about 40 seconds) the projector is ready for use.

5. If you've connected a Windows-based computer to the projector, you may see a New Hardware Wizard saying your computer has found a plug-and-play monitor; if so, click **Cancel**.

---

### **warning**

*Never look into the lens when the lamp is on. This can damage your eyes, and is especially dangerous for children.*

---

---

**note**

To focus and adjust the image, see page 24. If a projected image fails to appear, see page 21 for help.

---

---

**note**

You can also preview all sources on one screen to help you select the desired source (see page 36).

---

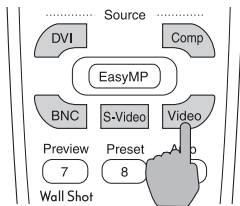

## Selecting the Image Source

Selecting the image source lets you switch between images input from different pieces of equipment connected to the projector (such as a computer or DVD player).

If you don't see the image you want, select it using the **Source** buttons either on the projector or the remote control.

The **Source** buttons work as follows:

- The projector has two **Source** buttons. Use the **Computer/DVI** button to switch between **EasyMP**, and between equipment connected to the **Computer** and **DVI** ports.  
Use the **Video/BNC** button to switch between equipment connected to the **Video**, **S-Video**, and **BNC** ports.
- The remote control has six **Source** buttons. Use them to switch between equipment connected to the port identified on each button, or select **EasyMP** to project wirelessly or from a memory card.

Note that the **Computer** and **BNC** ports can be set up to use different input signals (for example, Analog RGB or RGB Video)—so if you have equipment connected to one of these ports, it's important to make sure the correct signal is selected to match the equipment you're using. You can change the input signal settings using the projector's menu system; see page 137.

# Troubleshooting Display Problems

Follow these guidelines if you're having trouble displaying an image.

## **You Can't Project an Image**

If you see a blank screen or a blue screen with the **No Signal** message, try the following:

- Make sure the cables are connected correctly, as described in Chapter 3.
- Make sure the power light is green and not flashing and the lens cap is off.
- If you've connected more than one computer and/or video source, you may need to press one of the **Source** buttons on the projector's control panel or the remote control to select the correct source. (Allow a few seconds for the projector to sync up after pressing the button.)
- If you're using a PC laptop, press the function key on your keyboard that lets you display on an external monitor. It may be labelled **CRT/LCD** or have an icon such as . You may have to hold down the **Fn** key while pressing it. Allow a few seconds for the projector to sync up after changing the setting.

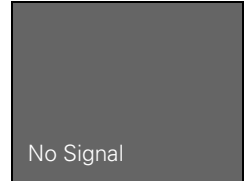

## **The Projector and Laptop Don't Display the Same Image**

If you're projecting from a laptop, and you can't see your image on the projection screen and on your computer at the same time, follow these guidelines.

*If you're using a PC laptop:*

- On most systems, there's a function key that lets you toggle between the LCD screen and the projector, or display on both at the same time. It may be labelled **CRT/LCD** or with an icon such as . You may have to hold down the **Fn** key while pressing it. Allow a few seconds for the projector to sync up after changing the setting.

- If the function key doesn't permit you to display simultaneously on both screens, you should check your monitor settings to make sure both the LCD screen and the external monitor port are enabled.

From the Control Panel, open the **Display** utility. In the Display Properties dialog box, click the **Settings** tab, then click **Advanced**. The method for adjusting the settings varies by brand; you may need to click a **Monitor** tab, then make sure the external Monitor port is set as your primary display and/or enabled. See your computer's documentation or online help for details.

### *If you're using Macintosh OS X:*

You may need to set up your system to display on the projector screen as well as the LCD screen. Follow these steps:

1. From the Apple menu, select **System Preferences**, then select **Displays**.
2. Make sure the **VGA Display** dialog box is selected.
3. Click the **Arrange** (or **Arrangement**) tab.

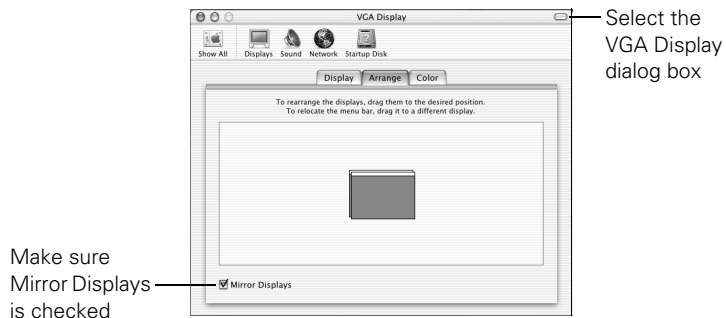

4. Make sure the **Mirror Displays** checkbox is selected.

## If you're using OS 8.6 to OS 9.x:

You may need to set up your system to display on the projector screen as well as the LCD screen. Follow these steps:

1. From the Apple menu, select **Control Panels**, then click **Monitors** or **Monitors and Sound**.
2. Click the **Arrange** icon.

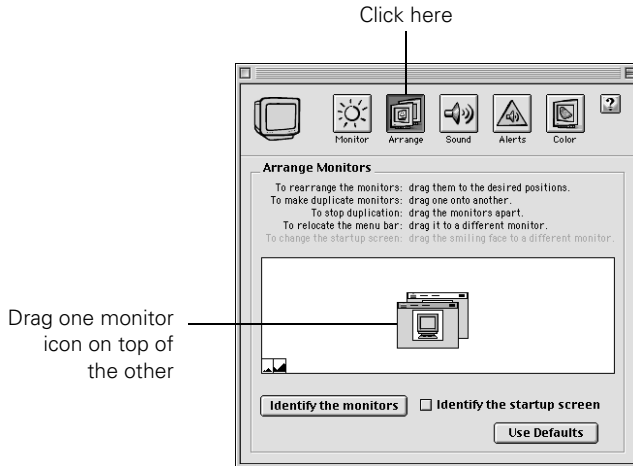

3. Drag one monitor icon on top of the other.

If the **Arrange** option isn't available, you may need to select one of the **Simulscan** resolution settings:

1. Click the **Monitor** icon.

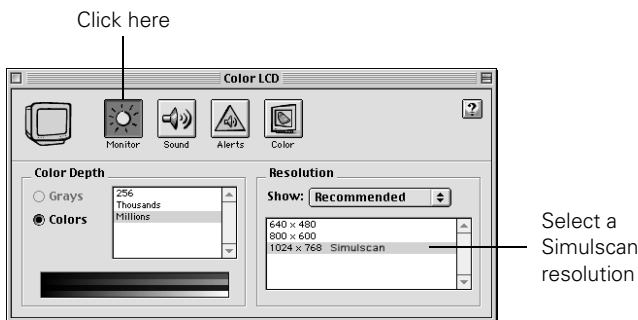

2. Select a **Simulscan** resolution as shown. (Allow a few seconds for the projector to sync up after making the selection.)

## *Adjusting the Image*

Once you see your image, you need to make certain adjustments:

- To focus or zoom your image, see below.
- If the image is too high or too low, you can reposition it. See page 25.
- If the image isn't square, see page 26.
- If a computer image displays incorrectly, see page 28.

If you need to fine-tune the image and/or sound, see Chapter 4.

### ***Focusing and Zooming Your Image***

Use the focus ring on the projector to sharpen the image.

Use the zoom ring on the projector to reduce or enlarge the image. Move the tab toward the **W** to increase the size, and toward the **T** to decrease it.

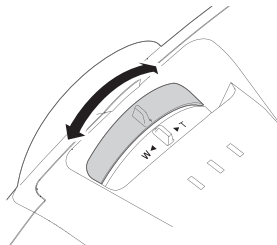

Focus ring

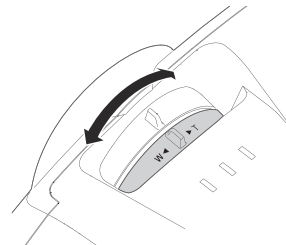

Zoom ring

If the image still isn't large enough, you may need to move the projector farther away from the screen. You can also use the **E-Zoom** buttons on the remote control to zoom in on a portion of the image. See page 39 for instructions.



## ***Adjusting the Height of Your Image***

If the image is too low on the screen, you can use the front adjustable foot to raise it.

1. Stand behind the projector. Press the blue foot release lever up and lift the front of the projector.

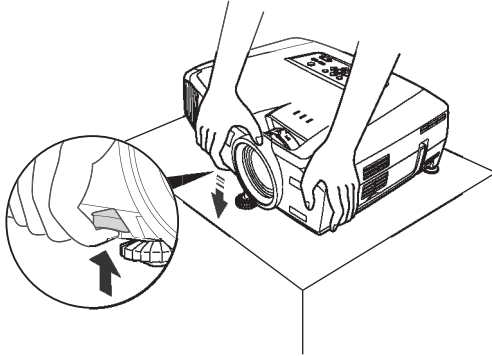

2. Once the image is positioned where you want it, release the lever to lock the foot in position.
3. If necessary, you can fine-tune the height or level the image by turning the projector's rear feet.

Raising the projector causes the image to distort or “keystone,” but you can manually correct the shape as described in the next section.

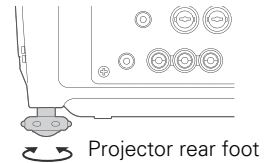

## Adjusting the Image Shape

In most cases, you can maintain a square or rectangular image by placing the projector directly in front of the center of the screen with the base of the lens level with the bottom of the screen.

Even if the projector is slightly tilted (within a range of 40° up or down), the projector has an automatic keystone correction function that detects and corrects vertical keystone distortion.

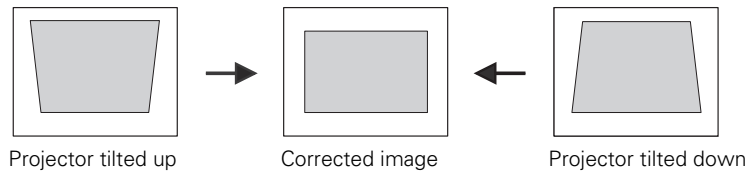

It takes about one second after projection starts for the image to be corrected. During this time, a vertical keystone correction gauge appears on the screen.

If your image is still distorted, you can correct it using either of these methods:

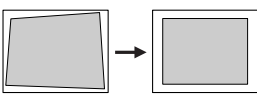
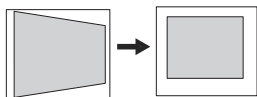
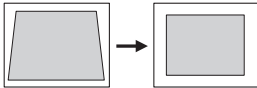

- If the image has two parallel sides but is wider on one side (top, bottom, left, or right), you can correct it using the **Keystone** keys on the projector's control panel or the projector's Keystone menu (see "Using Keystone Correction" on page 27).
- If the image has no parallel sides, you can adjust its shape using **Quick Corner™** (see page 37).

You cannot use both keystone correction and Quick Corner at the same time.

## Using Keystone Correction

To adjust your image when it is wider on one side, do the following:

- Look at the shapes of the icons on the projector's four **Keystone** buttons. Press the button whose icon is the mirror image of the shape of your screen image. Continue pressing the button until you are satisfied with the shape of the image.

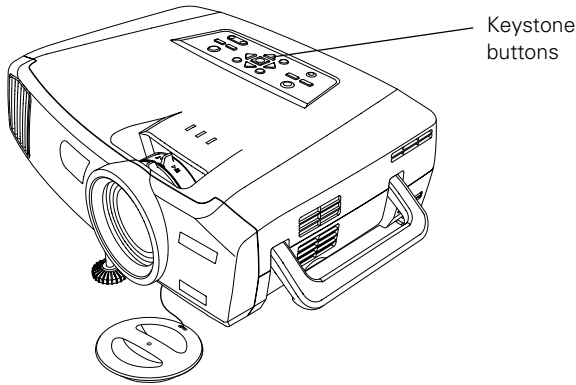

- Or press the **Menu** button on the remote control, select the **Setting** menu, and press **Enter**. From the **Setting** menu, select **H/V-Keystone** in the **Keystone** menu and press **Enter**. Select **V-Keystone** (for vertical keystone distortion) or **H-Keystone** (for horizontal keystone distortion) and press **Enter**. Use the  pointer button on the remote control to adjust the keystone setting as needed.

### **note**

*The image will be slightly shorter after adjusting. If it's important to maintain the correct aspect ratio, use the menu system to perform keystone correction, then adjust the **Height** setting as needed. See page 129.*

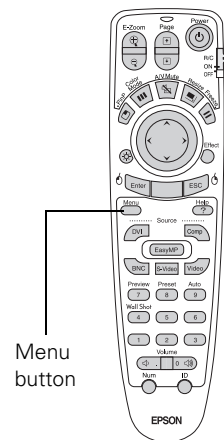

## Correcting Computer Images

### note

*You must be projecting an image for this button to have any effect. The Auto button works only with computer images.*

If you're connected to a computer and the image doesn't look right, press the **Auto** button on the remote control (or the **↵ Auto/Enter** button on the projector's control panel). This automatically resets the projector's tracking, sync, resolution, and position settings.

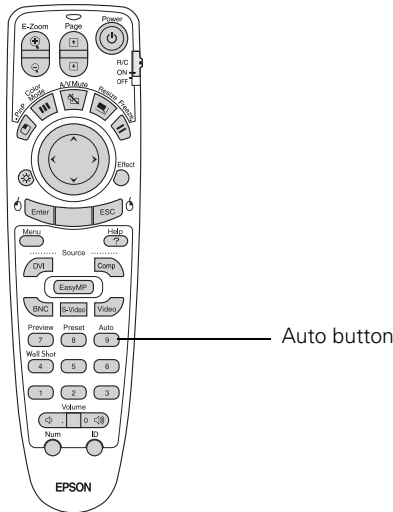

If vertical bands appear in the projected image and the **Auto** button doesn't correct the problem, hold down the **Shift** button on the projector's control panel while pressing either the **Tracking +** or the **Tracking -** button.

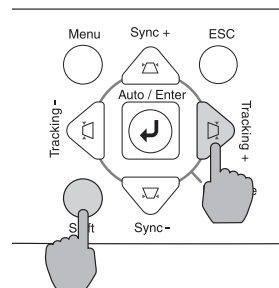
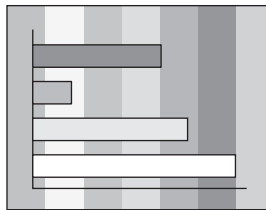

If the image appears fuzzy or flickers and the **Auto** button doesn't correct the problem, hold down the **Shift** button while pressing either the **Sync +** or **Sync -** button.





# 2

## *Using the Remote Control*

The projector includes a number of tools to enhance your presentation. All of them can be accessed using the remote control, which lets you operate the projector from anywhere in the room—up to 30 feet away.

You can use the remote control to adjust the picture and sound (page 35), or as a pointer or drawing tool to highlight your presentation (page 41). You can also use it to make automatic color corrections that let you project images onto any surface (page 43), or as a wireless mouse when projecting from a computer (page 44). Finally, you can use it to prevent unauthorized use of your projector by assigning the projector a password.

This chapter covers:

- Activating and using the remote control
- Controlling the picture and sound
- Highlighting your presentation
- Projecting images without a screen
- Operating your computer with the remote control
- Enabling password protection

---

**note**

*For information and resources to help you give the most professional presentation, be sure to visit [presentersonline.com](http://presentersonline.com).*

---

## Activating and Using the Remote Control

The remote control has an ON/OFF switch on its side, as shown. Before using the remote, make sure batteries are installed as described on page 34, then push up on the ON/OFF switch to turn it on.

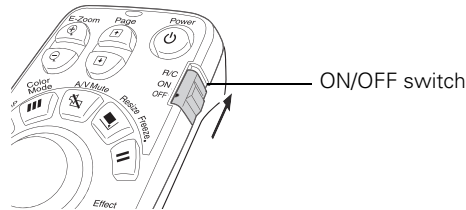

### **note**

*If a button is pressed longer than 60 seconds, the remote control stops operating to conserve power. When you release the button, normal operation resumes.*

Turn off the remote control before transporting or storing it; this prevents the batteries from discharging if something presses against one of the buttons.

Here are some additional tips:

- Point the remote control either at the front or back of the projector, or at the screen.
- Stand within 30 feet of the projector. If you want to operate the projector from a greater distance, a remote control cable set is available (see page 14).
- When presenting in a darkened room, press the  light button to make the buttons on the remote light up temporarily.
- Avoid using the remote under bright fluorescent lamps or in direct sunlight, or the projector may not respond properly.



## Using the Navigation Buttons

The remote control has various buttons that let you navigate the projector's help and menu systems; they also let you use the drawing tools to highlight your presentation. If you've connected a computer, the buttons can be used in place of your computer's mouse, letting you walk about freely while controlling your presentation.

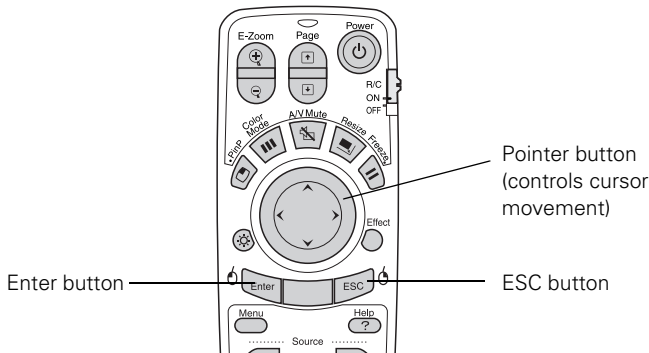

For details on using the buttons to control specific features, see the following sections:

- to highlight your presentation, see page 41
- to use the remote control in place of your computer's mouse, see page 44
- to navigate the projector's menu system, see page 124
- to create your own startup screen, see page 132
- to use the remote to control more than one projector, see page 135
- to use the projector's help system, see page 176

### **note**

*The projector has equivalent buttons that you can use on its control panel:*

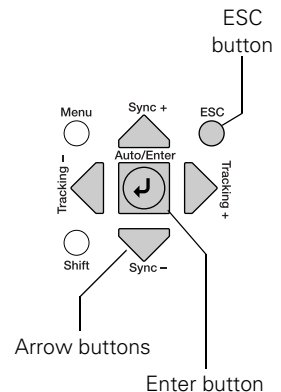

## Replacing the Batteries

If the projector stops responding to the remote control, check the following:

- Make sure the remote control's ON/OFF switch (shown on page 32) is in the ON position.
- Press the ☼ light button and check to see if the buttons on the remote control light up. (If you're in a bright room, you may not be able to see them light.)

### caution

*When replacing batteries, take the following precautions:*

- *Replace the batteries as soon as they run out. If the batteries leak, wipe away battery fluid with a soft cloth. If fluid gets on your hands, wash immediately.*
- *Do not expose batteries to heat or flame.*
- *Dispose of used batteries according to local regulations.*
- *Remove the batteries if you won't be using the projector for a long period of time.*

If the buttons do not light up, replace the batteries as described below:

1. Turn the remote control over.
2. Press down on the ridges at one end of the battery cover as you slide the cover off.
3. Install two AA batteries, inserting the flat (negative) ends in first.
4. Slide the cover back in place.

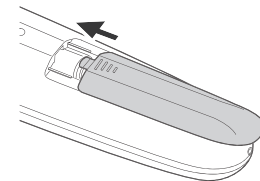
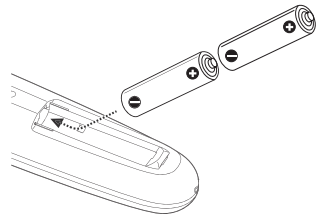
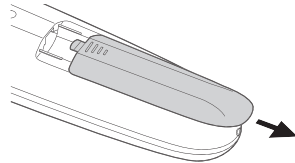

## Controlling the Picture and Sound

You can use the remote control to preview and select your picture sources, temporarily turn off the picture and sound, freeze the action, zoom in on the picture, display a picture-in-picture image, and adjust the volume.

### Switching Between Picture Sources

If your projector is connected to more than one computer and/or video source, you can switch between the different sources:

- On the projector's control panel, there are two **Source** buttons: Press the **Computer/DVI** button to switch between EasyMP and equipment connected to the **Computer** and **DVI** ports. Or press the **Video/BNC** button to switch between equipment connected to the **Video**, **S-Video**, and **BNC** ports.
- On the remote control, there are six **Source** buttons. Use them to switch between equipment connected to the port identified on each button, or to use EasyMP to project wirelessly or from a memory card.

Note that the **Computer** and **BNC** ports can be set up to use different input signals (for example, Analog RGB or RGB Video)—so if you have equipment connected to one of these ports, it's important to make sure the correct signal is selected to match the equipment you're using. You can change the input signal settings using the projector's menu system; see page 137.

After you select a source, the screen goes dark for a moment before the image appears.

#### **note**

*You can use the projector's menus to fine-tune the picture and sound quality as described in Chapter 4.*

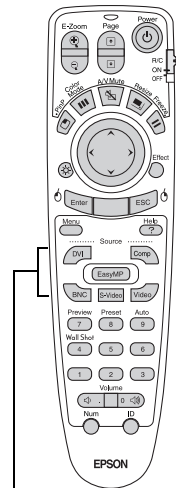

Source buttons

## Previewing Picture Sources

You can use the Preview function to help you select the image source.

1. Press **Preview** on the remote control.

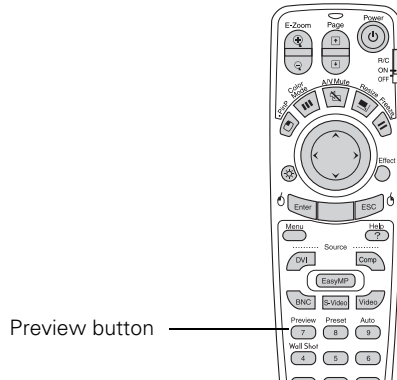

### note

*Movies are displayed as still images on the preview screen.*

You see the currently selected source displayed in the main window, as shown. All other sources (including the currently selected source) are displayed in smaller preview windows on the right side and at the bottom. If no equipment is connected to a port, if there is no incoming signal, or if the signal is out of range, the preview window for that source appears blank.

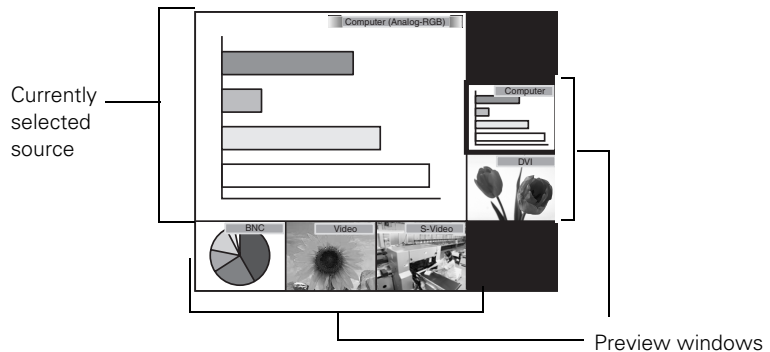

### note

*A red highlight surrounds the preview window for the currently selected source. You can use the  pointer button on the remote control to highlight a different source, and then press **Enter** to display it.*

2. Press one of the **Source** buttons on the remote control to switch to the desired source, and press **Enter** to change the source and exit the screen. Or press **ESC** to exit the preview screen without switching sources.

## Adjusting the Image Shape

Even if your projected image has no parallel sides, you can correct the problem with Quick Corner. Follow these steps:

1. Press the **Menu** button on the remote control (or on the projector's control panel).
2. Select the **Setting** menu and press **Enter**.
3. From the Setting menu, select **Keystone** and press **Enter**.
4. Select **Quick Corner** and press **Enter**.

You see this screen:

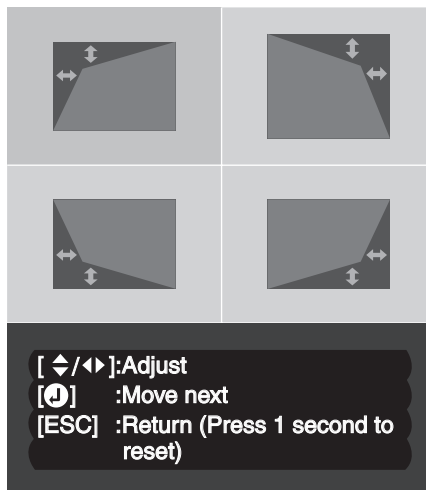

5. Press the **Enter** button to select the corner you want to adjust.
6. Use the  pointer button on the remote control (or the arrow buttons on the projector) to adjust the shape.
7. Repeat steps 5 and 6 as needed to adjust any remaining corners.
8. When done, press the **ESC** button on the remote control or projector's control panel to exit the menu system.

If **Quick Corner** remains selected in the Keystone menu, the Quick Corner screen appears whenever you press the projector's **Keystone** buttons. You can then follow steps 5 through 8 above to correct the shape of your image, or press **ESC** to exit Quick Corner.

---

### **note**

*For more information on using the menu system, see Chapter 6.*

---

---

### **note**

*If you are not satisfied with the corrections made, press the **ESC** button for one second to reset the screen to its original shape.*

---

## Turning Off the Picture and Sound

You can use the A/V Mute button on the remote control to turn off the image and sound and darken your screen. (If you've connected a computer to the projector's Computer port and an external monitor to the projector's Monitor Out port, the monitor will continue displaying.) This feature is useful if you want to temporarily redirect your audience's attention without the distraction of a bright screen.

- To turn off the picture, press the A/V Mute button. The screen goes dark.
- To turn the image back on, press the button again.

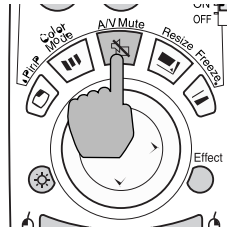

You can also have an image, such as a company logo, display on the screen whenever you press the A/V Mute button (see page 132).

## Stopping Action

You can use the remote control to stop the action in your video or computer image.

### note



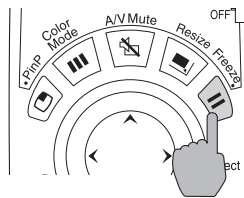

*This function pauses the image, but not the sound. Also, because the source continues to transmit signals, you won't resume the action from the point you paused it.*



- Press the Freeze button to stop the action and keep the current image on the screen. The sound continues.
- Press the Freeze button again to restart it.

## Zooming Your Image

You can zoom in on a portion of the image using the E-Zoom buttons on the remote control.

1. Press the E-Zoom  button on the remote control.  
You see a crosshair indicating the center of the zoom-in area.
2. Use the  button to position the crosshair.
3. Continue pressing the E-Zoom  button to enlarge the selected area up to 4X.
4. While the image is enlarged, you can:
  - Use the  button to pan about.
  - Press the E-Zoom  button to zoom out.
5. When done, press the ESC button to return to the original size.

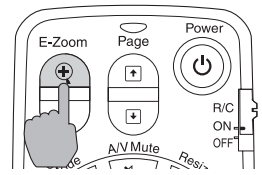

## Displaying a Picture-in-Picture Video

If you're displaying an image from equipment connected to the DVI, Computer, or BNC port(s), you can open up a smaller picture-in-picture window on the screen. This window can display video from equipment connected to either the Video or S-Video port.

### Setting Up the P-in-P Image

Before starting, make sure the computer or video equipment for your main image is connected to the DVI, Computer, or BNC port(s), and the video equipment for the P-in-P window is connected to the Video or S-Video port. Then select the corresponding video setting:

1. Press the Menu button on the remote control, and enter the Setting menu.
2. Highlight P in P, use the pointer button to select either Composite or S-Video, then press Enter.
3. Press ESC to exit the menu system.

---

### **note**

*The Picture-in-Picture function does not work for RGB video images.*

---

---

### **note**

*Select Composite if your P-in-P video equipment is connected to the Video port.*

---

## Displaying the P-in-P Image

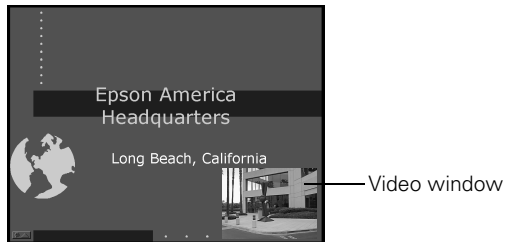
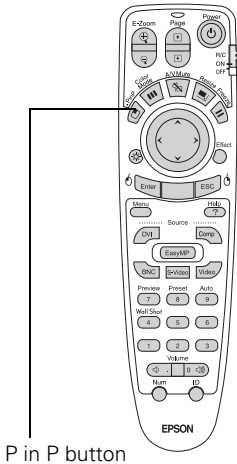

Make sure your main image source is displayed, then follow these steps to display and use the Picture-in-Picture window:

1. Press the P in P button on the remote control.
2. Use the  pointer button to reposition the video window; use the E-Zoom buttons to reduce or enlarge it.
3. Once the window is located and sized the way you want it, press the Enter button; your video continues playing on the screen.



4. When you're finished viewing the Picture-in-Picture, press the P in P or  pointer button again. The window disappears.

## Controlling the Volume

To change the volume, press the  or  side of the Volume button.

### **note**

To temporarily shut off the sound (and picture), press the A/V Mute button.

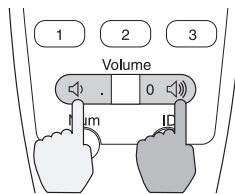

If necessary, you can adjust the tone using the projector's menu system. See page 131.



# Highlighting Your Presentation



You can display a pointer to call out something on the screen, or draw straight or curved lines to emphasize particular points. There are three preset pointer tools you can choose from, and each one can be customized for a different look.

## Using the Pointer Tool

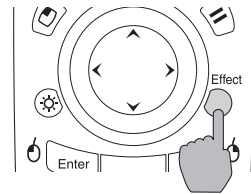
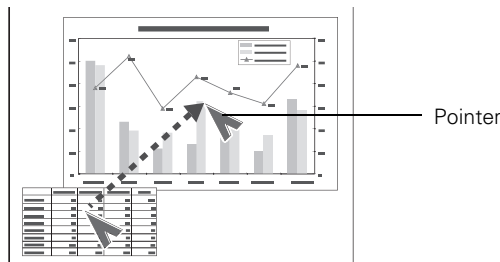
1. To activate the pointer tool, press the **Effect** button on the remote control. A pointer appears on the screen.



If you prefer to use a different style of pointer, continue pressing the **Effect** button to select the desired style. Three preset options are available, but you can customize the look of each one (see page 42).

2. Use the  pointer button on the remote control to position the pointer on the screen.
3. To draw a straight line, place the pointer where you want the line to begin and press **Enter**. Move the pointer to where you want the line to end, and press **Enter** again.
4. To draw a curved line, place the pointer at the start of the line, then press and hold the **Enter** button until it lights. Then use the  pointer button to move the pointer and draw on the screen. Press **ESC** when done.
5. If you want to draw additional lines, repeat steps 3 and 4.
6. When done drawing, press **ESC** to clear the screen.

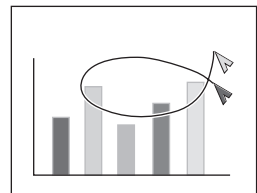

## Customizing the Pointer Tools

You can customize the shape and size of each of the three pointer tools, select the color and width of the line made with each pointer, and set how fast you can move the pointer across the screen.

1. Press the **Menu** button on the remote control, highlight the **Effect** menu, and press **Enter**.

You see this screen:

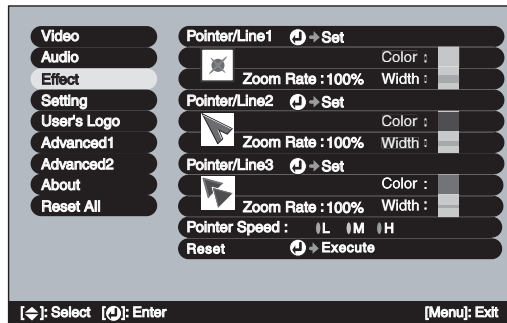

2. For each of the three Pointer/Line icons, you can change the following settings:

- **Shape**

Lets you select one of the following pointer shapes:



- **Zoom Rate**

Changes the size of the pointer

- **Color**

Changes the color of the line you can draw using the pointer

- **Width**

Changes the line width

3. You can also change the **Pointer Speed** setting to adjust how fast the pointer tool moves across the screen.
4. When done, press **ESC** until you exit from the menu system.

## Projecting Images Without a Screen

Even if you don't have a screen, you can project images onto surfaces like blackboards and colored walls without loss of image color. Your projector has a sensor that measures the conditions of the projection surface and automatically adjusts the colors and shading of your image. For example, if you're projecting onto a surface near a window, your image appears clear and well-defined rather than faint.

### Making Initial Color Corrections

Press the **Wall Shot** button on either the remote control or the projector's control panel while projecting an image.

Wall Shot's status appears in the upper right corner of your screen. Then you see a sequence of colors flash for approximately five seconds while the sensor measures the conditions of the projection surface and adjusts the image.

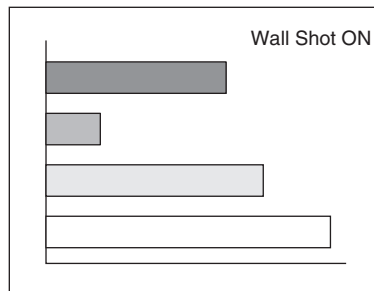

When you turn the projector off, the projector stores the correction values obtained by the last Wall Shot measurements. This is useful if you're projecting against the same surface and under the same conditions. To retrieve these corrections, just press the **Wall Shot** button again while projecting an image.

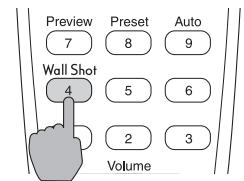

#### **note**

*If the status message indicates that Wall Shot is off, press the **Wall Shot** button again to turn it on.*

## ***Adjusting Color Corrections for a New Surface***

Adjust the correction values if you're projecting on a new surface or in a new location.



1. Press the **Wall Shot** button on the remote control or projector while you're projecting an image. Wait for the Wall Shot status screen.
2. Press the **Wall Shot** button until you see **Wall Shot Readjustment** on the status screen.

You see a sequence of colors flash for about five seconds as the projector adjusts the color correction values for the new projection surface.

## ***Operating Your Computer with the Remote Control***

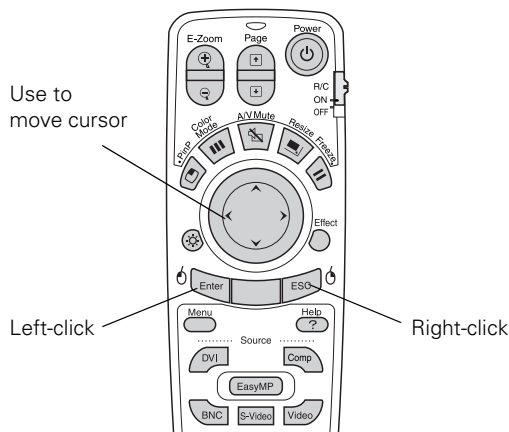
If you've connected a computer to the projector with a USB cable, as described on page 56, you can use the remote control in place of your computer's mouse. This gives you more flexibility when delivering PowerPoint and other slideshow-style presentations, since you won't have to stand next to the computer to change slides.



- Use the  pointer button to move the cursor on the screen.
- Press the **Enter** button to left-click, or press it twice to double-click; press the **ESC** button to right-click.
- To drag-and drop, hold down the **Enter** button for about one second until it lights. Then use the  pointer button to drag the object. When it's where you want it, press **Enter** to release it.
- Use the **Page** buttons to move through a slideshow.

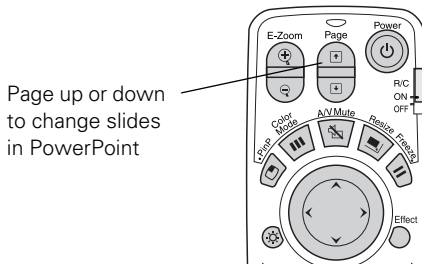

## *Enabling Password Protection*

To prevent unauthorized use, you can assign the projector a password. If you do, a screen will appear requesting the password whenever the projector is plugged in. If an incorrect password is entered three times in succession, the projector's operation is locked and the power cord must be disconnected and reinserted to redisplay the password screen. If an incorrect password is entered nine times in succession, the user must contact the dealer to unlock the projector.

The default setting for the Password Protect function is off. Follow these steps to turn password protection on:

1. Press the **Freeze** button on the remote control for about five seconds.

### **note**

*It's a good idea to write your password down. Also, make a note of the "Request Code: xxxxx" number that appears in the Password Protect Release screen. If you do forget the password, you'll need this code when you contact the dealer.*

*If you leave the projector plugged in, the Password Protect Release screen will not appear. You only need a password if you unplug and reconnect the power cable.*

You see this screen:



---

### **caution**

*If you lose the remote control, you will not be able to enter the password. Keep the remote control in a safe place at all times.*

---

2. Use the  pointer button to set **Security Lock** to **ON**. Then press the **Enter** button.
3. Select **Password** and press the **Enter** button.
4. When you see a message asking if you want to change the password, select **Yes** and press **Enter**.
5. Press the **Num** button on the remote control. When it lights, the numeric keypad is activated.
6. Use the numeric keypad to enter a four digit password. (The default setting is 0000.)
7. When you see a confirmation message, reenter the password. Then press the **Menu** button to exit the screen.
8. Press the **Num** button on the remote control to deactivate the numeric keypad.

## ***Starting the Projector with a Password***

When Password Protect is enabled, you see this screen when you plug in the projector:



1. Press the Num button on the remote control to activate the numeric keypad.
2. Enter the four digit password.
3. Press the Num button to deactivate the numeric keypad.

The Security Lock Release screen closes, and projection begins.





# 3

## *Connecting to Computers, Cameras, and Other Equipment*

This chapter tells you how to connect the projector to a laptop or desktop computer, or to video equipment, such as a VCR or DVD player. You can also connect the projector to a digital camera, video camera, external speakers, or an external monitor.

Follow the instructions in this chapter on:

- Connecting to a computer
- Connecting an external monitor
- Connecting video equipment
- Connecting to a digital camera
- Playing sound through the projector

---

## Connecting to a Computer

---

### **note**

*If you connect a Windows-based computer to the projector, you may see a New Hardware Wizard saying your computer has found a plug-and-play monitor; if so, click **Cancel**.*

---

---

### **note**

*If you're using a PowerBook or an older Macintosh and you can't connect the cable to your computer, you may need to use the Macintosh desktop adapter, as shown on page 55 (available from EPSON; see page 14).*

---

You can connect the PowerLite projector to any computer that has a standard video output (monitor) port, including desktop models, PC notebook and laptop computers, Macintosh PowerBooks and iBooks, and hand-held devices. You can connect up to three computers at the same time:

- To connect to the **Computer** port (standard VGA cable connection), see page 51.
- To connect using the **BNC** ports, see page 53.
- To connect using the **DVI** (Digital Video Interface) port, see page 54.

After connecting to the computer, you may also want to:

- connect a **USB** cable so you can use the remote control as a mouse; see page 56
- connect a **monitor** to the projector so you can view your presentation close-up as well as on-screen (not necessary if you're using a laptop); see page 57
- connect an **audio** cable to play computer audio; see page 65

## Connecting to the Computer Port

Follow these instructions:

1. You can connect to the Computer port in the following ways:
  - using the VGA computer cable that came with the projector (the monitor port on your computer must be a mini D-sub 15-pin port)
  - using the optional BNC/VGA component video cable, if your computer provides video output through BNC connectors (see page 14).
2. If you're using the VGA computer cable, connect one end to the projector's Computer port, and the other end to your computer's monitor port. Then go to step 4.

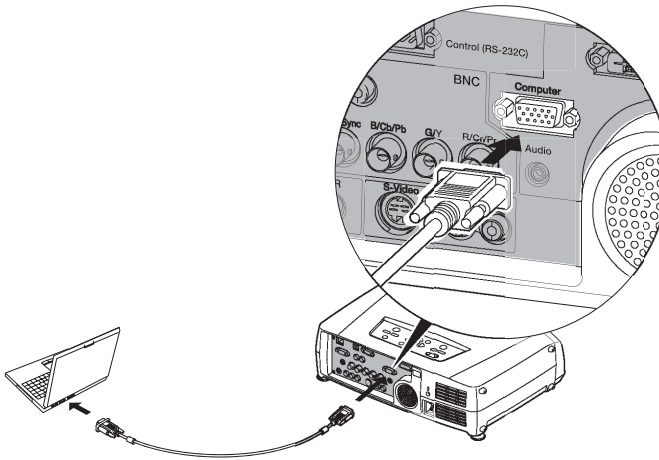

### caution

*Don't try to force a connector to fit a port with a different shape or number of pins. You may damage the port or connector.*

VGA computer cable



BNC/VGA cable



3. If you're using the optional BNC/VGA cable, connect the VGA connector to the projector's **Computer** port and plug the BNC connectors into your computer's monitor ports.

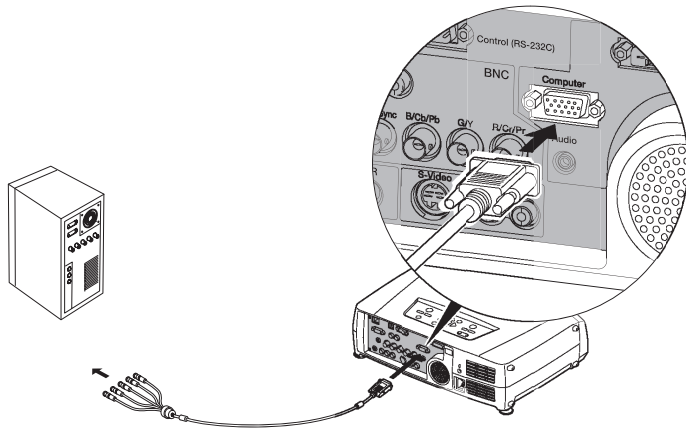

4. Optionally, you can connect an external monitor (see page 57), play sound through the projector (see page 65), or connect a USB cable to use the remote control as a mouse (see page 56).
5. When you've finished making any connections, see Chapter 1 for instructions on turning on the projector and adjusting the image. Once the projector is turned on, be sure to:
  - Enter the projector's Setting menu, then make sure Computer Input is set to **Analog-RGB**. See page 137.
  - After exiting the menu system, press the remote control's **Comp1** button, or repeatedly press the **Computer/DVI** button on the projector's control panel to select the correct source. **Computer (Analog-RGB)** should appear on the screen.

## Connecting to the BNC Connectors

1. Obtain a commercially available standard BNC cable.
2. Plug the BNC connectors into the projector's B/Cb/Pb, G/Y, and R/Cr/Pr connectors as shown below. Depending on your computer's video card, you may have to connect to the projector's V Sync and H/C Sync connectors too. (See your computer documentation for more information.)

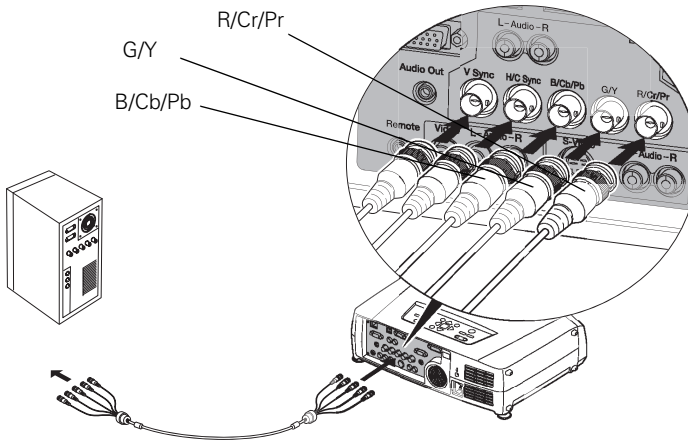
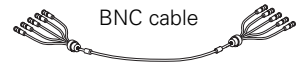

3. Plug the connectors on the other end of the cable into the BNC video out connectors on your computer.
4. Optionally, you can connect an external monitor (see page 57), play sound through the projector (see page 65), or connect a USB cable to use the remote control as a mouse (see page 56).
5. When you've finished making all necessary connections, see Chapter 1 for instructions on turning on the projector and adjusting the image. Once the projector is turned on, be sure to:
  - Enter the projector's Setting menu, then make sure the BNC Input is set to **Analog-RGB**. See page 137.
  - After exiting the menu system, press the **BNC** button on the remote control or repeatedly press the **Video/BNC** button on the projector's control panel to select the correct source. **BNC (Analog-RGB)** should appear on the screen.

## Connecting to the DVI Port

---

### **note**

*Various types of DVI cables are offered on the market. Be sure to use only a cable with DVI to DVI or DVI to DFP connectors.*

---

1. Obtain a DVI digital video cable (either DVI to DVI or DVI to DFP; see page 14 for details about ordering a cable from EPSON).
2. Connect the cable to the projector's DVI port as shown.

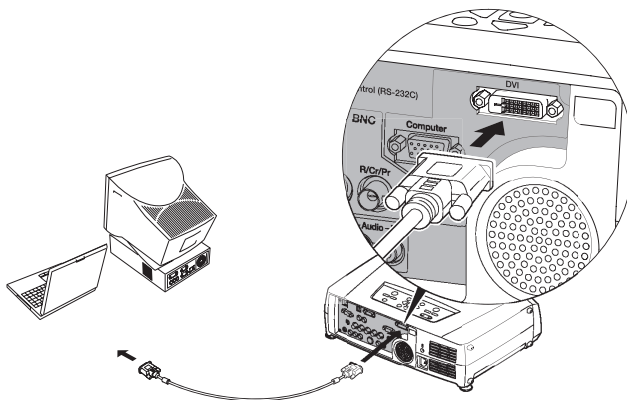

3. Connect the other end to your computer's DVI port.
4. Optionally, you can connect an external monitor (see page 57), play sound through the projector (see page 65), or connect a USB cable to use the remote control as a mouse (see page 56).
5. When you've finished making any connections, see Chapter 1 for instructions on turning on the projector and adjusting the image. Once the projector is turned on, press the DVI button on the remote control, or press the **Computer/DVI** button on the projector's control panel to select DVI as the image source.

## Using the Macintosh Desktop Adapter

If you have an older desktop Macintosh or PowerBook, the VGA cable may not fit when you try to connect it. If so, you'll need to use the Macintosh desktop adapter to connect the VGA cable to your computer. This is available from EPSON (see page 13).

1. To use the adapter, remove its cover as shown and set its DIP switches according to the resolution you want to use, such as 16-inch mode. See your Macintosh documentation for instructions.

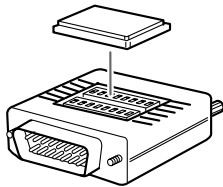

2. Replace the cover and connect the adapter to the VGA cable. Then plug the cable (with the adapter) into the video port on your Macintosh.
3. Tighten the screws on the connectors.

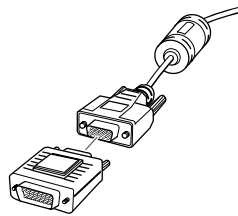

## Connecting the Cable for Remote Mouse Control

If you've connected a computer as described in this chapter, you can use the projector's remote control as a wireless mouse. This lets you control your computer and click through slideshow-style presentations, such as PowerPoint, from up to 30 feet away.

### note

The remote mouse control function may not operate correctly on systems that have been upgraded from an earlier version of Windows.

The wireless mouse function is supported on systems with a USB port running Windows XP, 98, 2000, or Me, or Macintosh OS 8.6 to OS X 10.2.

1. Locate the USB cable that came with your projector.
2. Connect the square end of the cable to the projector's  USB port.

### note

For details on using the remote control in place of your computer's mouse, see page 44.

Use to move cursor

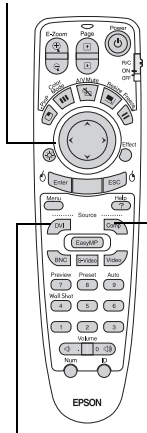

Left-click Right-click

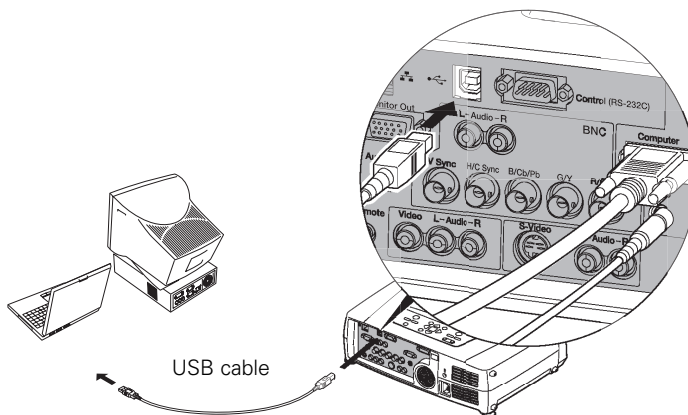

3. Connect the flat end of the cable to any available USB port on your laptop or desktop computer.
4. In the projector's menu system, set the **COM Port** setting in the **Advanced 2** menu to **USB**. See the instructions beginning on page 124 to use the menu system.
5. If necessary, configure your computer to work with an external USB mouse. See your computer documentation for details.



## Connecting an External Monitor

If you want to monitor your presentation close-up (on a monitor placed beside the projector) as well as on the screen, you can connect an external monitor.

To attach an external monitor, connect it to the projector's **Monitor Out** port, as shown:

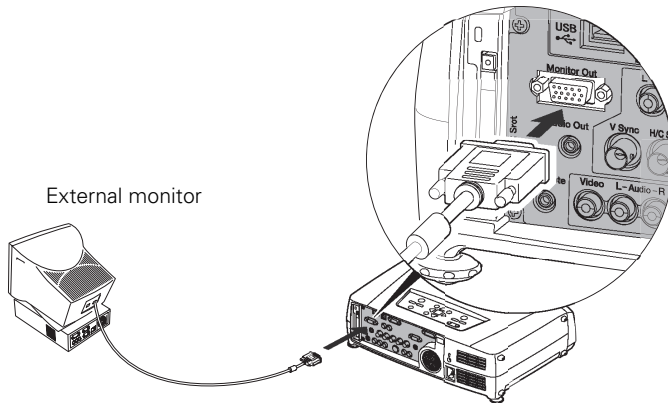

Follow these guidelines to view images on the monitor:

- The monitor displays the currently selected computer source. Press the **Preview** button on the remote control if you want to display all the active sources at the same time (see page 36).
- You can also view images on the monitor while the projector is in Standby mode, if you've set **Network ON** in the Advanced 1 menu (see page 138).

## Connecting to Video Equipment

You can connect up to four video sources to the projector at the same time. Before starting, look at your video equipment to determine its available video-output connections:



RCA connector  
(composite video)



S-video connector  
(4-pin mini-DIN)



BNC connector  
(component video)

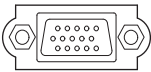

VGA connector  
(RGB video)

- If your video player has a yellow RCA-style video output connector, see “Connecting a Composite Video Source” on page 59.
- If your video player has an S-video connector, see “Connecting an S-Video Source” on page 60.
- If your video player has a component video port (three connectors labeled either Y/Cb/Cr or Y/Pb/Pr), see “Connecting a Component Video Source” on page 61.
- If your video player has an RGB video port (either a single connector for a VGA-style monitor cable, or three connectors labeled R/G/B), see “Connecting an RGB Video Source” on page 62.

After connecting any video cables, you may also want to:

- connect a monitor to the projector so you can view your presentation close-up as well as on-screen; see page 57
- connect an audio cable to play sound through the projector; see page 65

## Connecting a Composite Video Source

1. Locate the RCA-style video cable provided with the projector.
2. Connect the cable to the yellow video output connector on your player and the yellow **Video** connector on the projector:

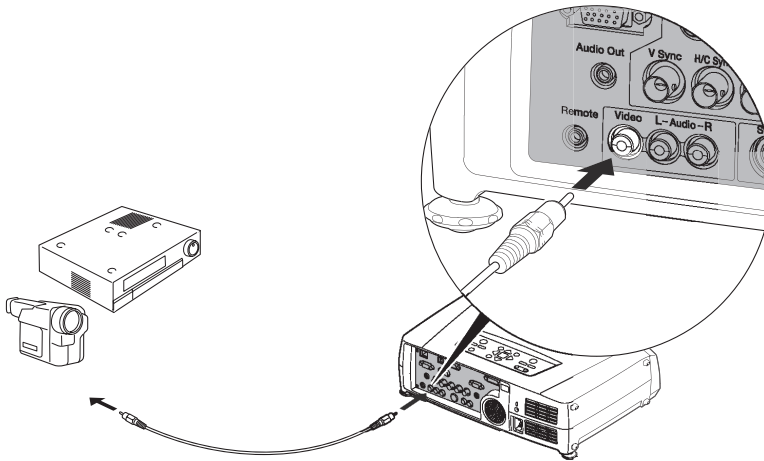

3. If you want to play sound through the projector, see page 65 for instructions on connecting an audio cable.
4. If you don't need to make any other connections, see Chapter 1 or the *Quick Setup* sheet for instructions on turning on the projector and adjusting the image. Once the projector is turned on, select the image source: press the **Video** button on the remote control, or press the **Video/BNC** button on the projector's control panel repeatedly until **Video** is displayed on the projected image.

## Connecting an S-Video Source

1. Locate an S-video cable (one is usually provided with your video equipment, or you can purchase one from EPSON; see page 13).
2. Connect the cable between the S-video connector on your player and the S-Video connector on the projector:

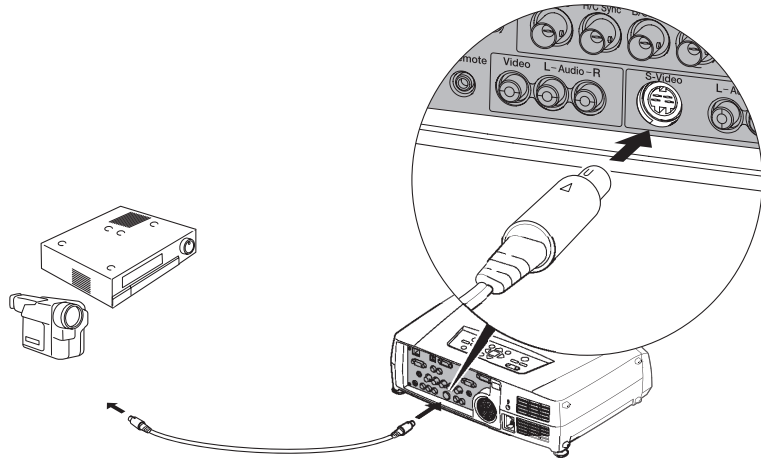

3. If you want to play sound through the projector, see page 65 for instructions on connecting an audio cable.
4. If you don't need to make any other connections, see Chapter 1 or the *Quick Setup* sheet for instructions on turning on the projector and adjusting the image. Once the projector is turned on, select the image source: press the **S-Video** button on the remote control, or press the **Video/BNC** button on the projector's control panel repeatedly until **S-Video** is displayed on the projected image.

## Connecting a Component Video Source

1. Locate a component video cable (one may be included with your video equipment).

Look at the connectors at one end of the cable. If they are bayonet-style (BNC) connectors, continue on to the next step. If they are RCA-style connectors, you'll need to attach commercially available BNC adapters to plug the cable into your projector.

2. Connect the cable to your player and the cable (with the adapters) to the BNC connectors on the projector. Match the Y/Cb/Cr (or Y/Pb/Pr) connectors on your player to the corresponding connectors on the projector.

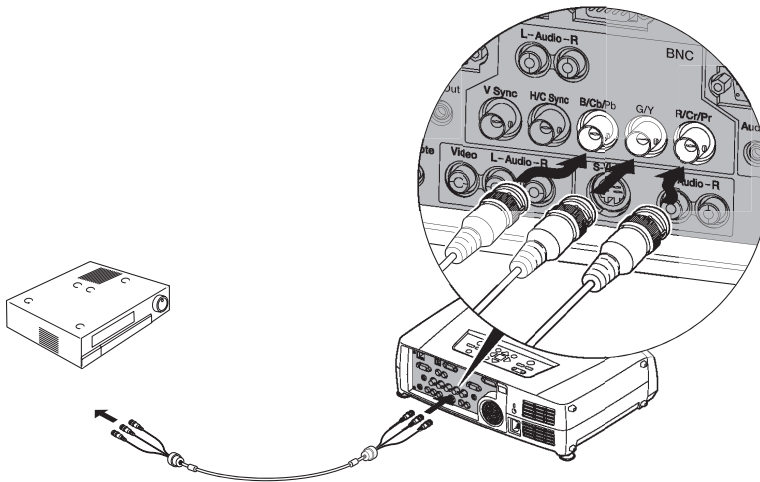

BNC adapters

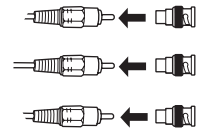

### **note**

*Be sure your video player is not an RGB video source. If you set the wrong source, image quality may suffer. Check your video player's documentation.*

3. If you want to play sound through the projector, see page 65 for instructions on connecting an audio cable.
4. If you don't need to make any other connections, see Chapter 1 for instructions on turning on the projector and adjusting the image. Once the projector is turned on, do the following:
  - Enter the projector's Setting menu, then change the BNC Input setting to YCbCr or YPbPr, as needed (see page 137).
  - After exiting the menu system, press the remote control's BNC button or repeatedly press the projector's Video/BNC button to select BNC as the image source.

---

**note**

*Be sure your video player is not a component video source. If you set the wrong source, image quality may suffer. Check your video player's documentation.*

---

## **Connecting an RGB Video Source**

Follow these instructions to connect the projector to a video player that has an RGB video output port. Depending on the type of connector on your player, you'll need to use the appropriate cable:

- If your player has a single VGA-style connector, see below.
- If your player has three connectors labeled R/G/B, see “Connecting Using a BNC-style Cable” on page 63.

### **Connecting Using a VGA-style Computer Cable**

1. Locate the VGA computer cable provided with the projector.
2. Connect the cable between the video port on your player and the Computer port on the projector.

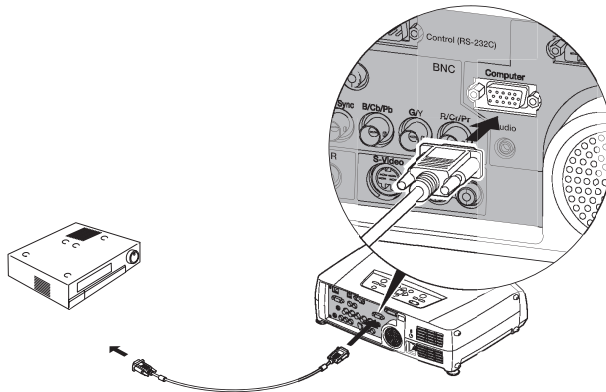

3. If you want to play sound through the projector, see page 65 for instructions on connecting an audio cable.
4. If you don't need to make any other connections, see Chapter 1 for instructions on turning on the projector and adjusting the image. Once the projector is turned on, be sure to:
  - Enter the projector's Setting menu, then change the Computer Input setting to **RGB-Video** (see page 137).
  - After exiting the menu system, press the remote control's **Comp** button or the projector's **Computer/DVI** button repeatedly to select the image source. (**Computer (RGB Video)** should appear on the screen.)

## Connecting Using a BNC-style Cable

1. Locate a BNC-style video cable (one may be included with your video equipment).
2. Connect the cable between your player and the corresponding R/G/B connectors on the projector.

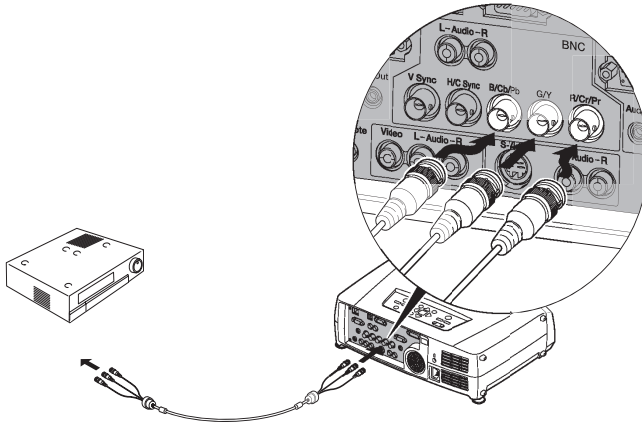

3. If you want to play sound through the projector, see page 65 for instructions on connecting an audio cable.
4. If you don't need to make any other connections, see Chapter 1 or the *Quick Setup* sheet for instructions on turning on the projector and adjusting the image. Once the projector is turned on, be sure to:
  - Enter the projector's Setting menu, then change the BNC Input setting to **RGB-Video** (see page 137).
  - After exiting the menu system, press the **BNC** button on the remote control or press the **Video/BNC** button on the projector repeatedly to select the correct image source (**BNC (RGB-Video)** should appear on the screen).

---

### **note**

*Be sure your video player is not a component video source. If you set the wrong source, image quality may suffer. Check your video player's documentation.*

---

## Connecting to a Digital Camera

### **note**

*Use a cable less than 10 feet long, and connect the camera directly to the projector. Your projector may not function correctly if you use a longer cable or connect your camera to a USB hub.*

You can connect your digital camera to the projector using the USB cable specified for your camera. Then you can use your camera's slideshow function or the projector's CardPlayer feature (see page 120) to present images on your camera.

1. Make sure there is no card inserted in the projector's card slot.
2. Connect one end of the USB cable to the USB Type A port on the projector, as shown.

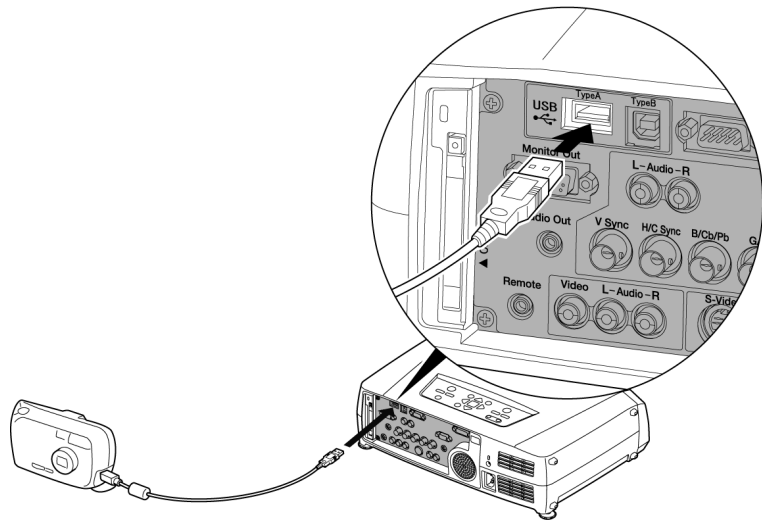

3. Connect the other end of the cable to your camera.

### **Removing the USB Cable**

If you're using CardPlayer to project your images, close the program before you remove the USB cable from the projector.

1. Position the cursor over the EJECT button in the upper right corner of the CardPlayer screen.
2. Press the Enter button on the remote control to close CardPlayer.
3. Remove the USB cable.



# Playing Sound Through the Projector

You can play sound through the projector's speaker system, or you can attach an external speaker system. (Attaching speakers to the projector instead of directly to the audio source lets you use the projector's remote control to adjust the sound.)

## Connecting Audio Equipment to the Projector

To play sound through the projector, follow these steps:

1. Locate the appropriate audio cable (two types are included with the projector). Which cable you use depends on how your equipment is connected:
  - If you have a computer connected to the **Computer** or **DVI** port, use the stereo mini-jack cable.
  - If you have video equipment connected to the **Video** or **S-Video** port, or to the **BNC** ports, use the RCA-style audio cable.
2. Connect the audio cable to the jack corresponding to the connected video source.

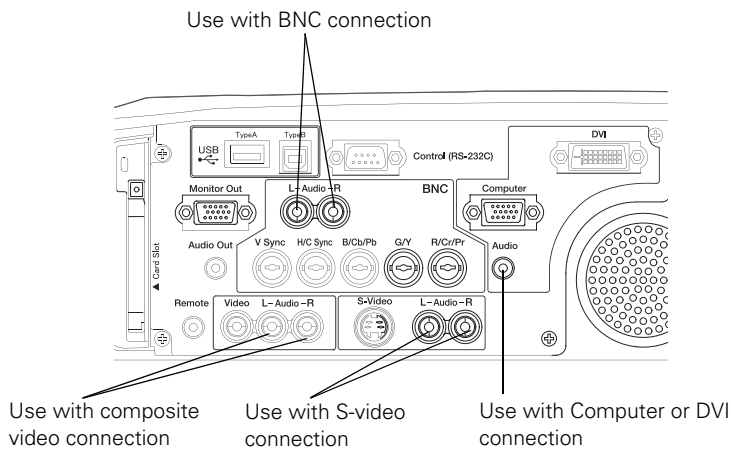

3. Connect the other end of the cable to the audio-output connector on your computer or video equipment.

## Connecting External Speakers

To connect speakers to the projector, follow these steps:

1. Obtain the appropriate cable to connect your speakers.

Depending on your stereo system, you may be able to use a commercially available audio cable with a stereo mini-jack connector on one end, and pin jacks on the other end. For some speaker systems, you may have to purchase a special cable or use an adapter to connect to your speakers.

2. Connect the stereo mini-jack end of the audio cable to the **Audio Out** port on the projector.

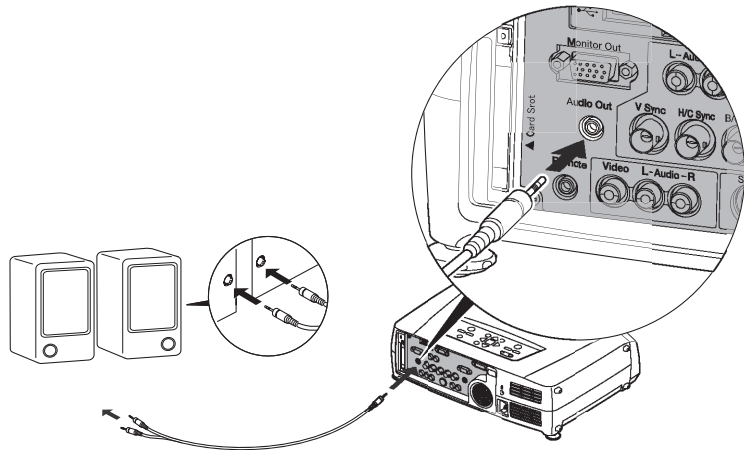

3. Connect the other end(s) of the cable to your speaker system. You may need to use an adapter to make the connection.

The projector's internal speaker system is disabled while sound is output to the external speakers.

# 4

## *Presenting Through a Wireless Network*

This chapter tells you how to send pictures to the projector through a wireless network. Using EMP NS Connection, you can project images shown on your computer screen—including text and graphics—directly to your audience. Because images are displayed in real-time, any changes you make on your PC or laptop are automatically mirrored on the screen.

You'll find instructions in this chapter on:

- Starting EasyMP
- Connecting to the projector in Ad Hoc mode or Access Point (infrastructure) mode
- Projecting wirelessly
- Using projector groups
- Removing the wireless 802.11b card

Before starting, make sure you've installed EMP NS Connection as described in Appendix A for each computer you want to be able to connect to the projector. Then follow the steps in this chapter to start EasyMP, configure your projector and computer, and run EMP NS Connection.

## Starting EasyMP

Before connecting to the projector, you have to switch it to EasyMP mode. Follow these steps:

1. Turn on the remote control, as described on page 32. Point it at the projector and press the **Power** button.
2. Press the **EasyMP** button on the remote control to select EasyMP as the source.
3. Insert the EPSON 802.11b card with the blue label facing outward.

### **note**

*Only the EPSON 802.11b card is guaranteed to work. Other brands may not be compatible.*

### **caution**

*Be careful to insert the card correctly, and never force the card in; doing so may damage it. The black end of the card protrudes from the slot when the card is fully inserted.*

*Always remove the card before transporting the projector. See page 99 for instructions.*

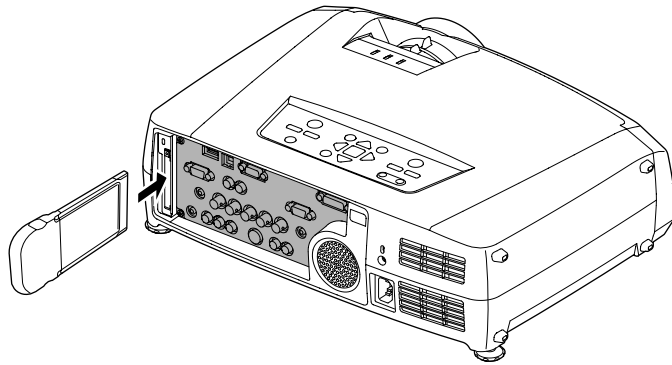

Once the card is inserted, you see one of these screens, depending on the currently selected mode:

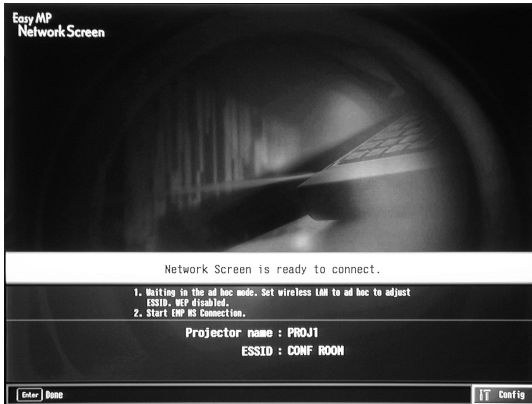

Ad Hoc mode

---

**note**

*If you see a message asking you to insert a LAN or memory card, check to make sure your 802.11b card is properly inserted.*

---

Access Point mode

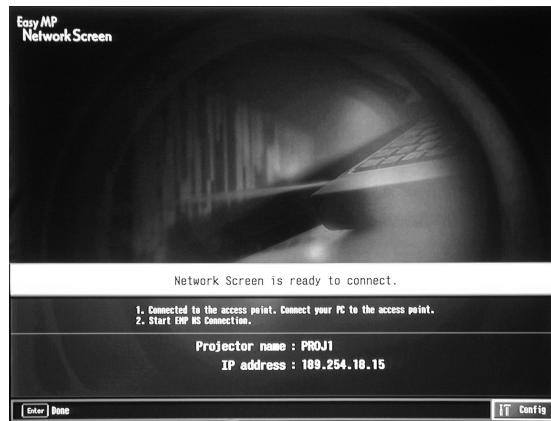

4. If you've already set up your computer and projector for the mode you want to use—Ad Hoc mode (also called computer-to-computer mode) or Access Point mode (also called infrastructure mode)—skip to “Projecting Wirelessly” on page 89.

Otherwise, continue on to the following section.

## Configuring the Connection

### note

Make sure you've installed the NS Connection software as described in Appendix A.

To connect to the projector over a wireless network, your computer must be running Windows 98, Me, 2000, or XP. Your Macintosh must be running OS X 10.2.4 or later. See Appendix A for complete system requirements for projecting wirelessly.

You can use NS Connection to connect to the projector and send images wirelessly in two modes: Ad Hoc mode or Access Point mode.

- **Ad Hoc mode** (computer-to-computer mode) lets you connect just one computer to the projector at a time; it's easy to set up, and the only equipment you need is a computer with a wireless (802.11b) network card or adapter, or a Macintosh with an AirPort® or AirPort Extreme card.
- **Access Point mode** (infrastructure mode) lets multiple users access the projector at the same time and easily trade off control over the projector. To use Access Point mode, you need a wireless (802.11b) access point, or an AirPort (or AirPort Extreme) base station, and one or more computers with wireless network cards or adapters.

Follow the instructions below for the mode you want to use.

### Using Ad Hoc Mode

In order to use Ad Hoc (computer-to-computer) mode, first adjust your projector and wireless card or adapter settings as described in this section.

### Configuring the Projector

1. Switch the projector to EasyMP and insert the EPSON 802.11b card (see page 68). You see this screen:



Config button

- To select **Config**, press the **Enter** button on the remote control.  
You see the following screen:

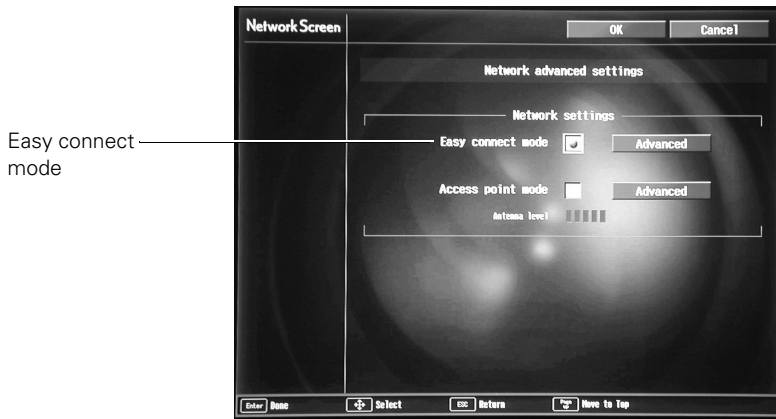

Make sure **Easy connect mode** is selected, as shown above. If not, use the  button on the remote control to highlight the checkbox next to **Easy connect mode**, then press **Enter** to select it.

- Use the  button to highlight **Advanced** (next to **Easy connect mode**), then press **Enter** to select it.

You see this screen:



---

**note**

*If you want to enter a blank space, use the space character that comes before the capital letter A.*

*If you want to enter numbers, press the **Num** button on the remote control. The button lights up to indicate that the numeric keypad mode is active. Press the **Num** button again to exit numeric keypad mode.*

---



---

**note**

*The projector keyword changes each time you turn the projector off and then on again, or remove and reinsert the 802.11b card. Check the keyword on the EasyMP Network screen whenever you start EasyMP, and enter that keyword on your computer. You can't connect using a previous keyword.*

---

4. Make sure the projector has a unique name, so you can identify it when connecting to it from your computer.

If you need to rename it, highlight the **Clear** button next to **Projector name**, then press **Enter** on the remote control to clear the text box. Then highlight the text box and press **Enter**. The outline of the text box turns green to indicate you are in input mode. Tilt the  button up to select individual letters in alphabetical order, or down to select letters in reverse order; then tilt the  button to the right to move to the next character position. When done typing the new name, press **Enter**.

5. To enable your computer to find the projector on the network, select the appropriate **Ad hoc mode settings**:
  - Select **ESSID ad hoc** if your network card supports an SSID or ESSID identifier (see page 75). Then highlight the **ESSID** text box, press **Enter**, and enter a name (for example, “CONF ROOM”). When you're done, press **Enter**. Note that the ESSID is case-sensitive (if you enter the name in uppercase on the projector, you must type it the same way on the computer connecting to the projector).
  - Select **Channel ad hoc** if your network card supports using channels instead of ESSID names to identify devices on the network. Then select a channel number in the **Channel** text box and press **Enter**. (Channel ad hoc mode is not supported for Macintosh.)
6. If you want to create a password for remote access to the projector, highlight the **Password for WEB control** checkbox, press **Enter**, and enter a password of up to 8 alphanumeric characters. When you're done, press **Enter**.
7. If you want to set up a security keyword so that only people who are in the same room as the projector can access it, turn **Projector keyword** on. Then when you want to connect to the projector, it displays a randomized four-digit number or “keyword” on the screen. When prompted by NS Connection, you can enter the keyword on your computer to connect (see page 92).



- When done making these settings, highlight the **OK** button at the top of the screen (you can either press the **ESC** button on the remote control or use the  button to highlight it), then press **Enter**. Highlight the **OK** button again and press **Enter** to return to the main EasyMP Network Screen.

Now you're ready to set up your computer for wireless projecting. Go to "Configuring the Network Settings for Windows" below, or "Setting Up Your Macintosh for Ad Hoc Mode" on page 75.

### *Configuring the Network Settings for Windows*

Before connecting to the projector, you need to make sure the settings for your laptop's or PC's network card match the settings you entered for the projector.

- Access your wireless network Properties window. For example, in Windows XP you would click **Start > Control Panel > Network and Internet Connections**. Then click the **Network Connections** icon.

You see a screen similar to this:

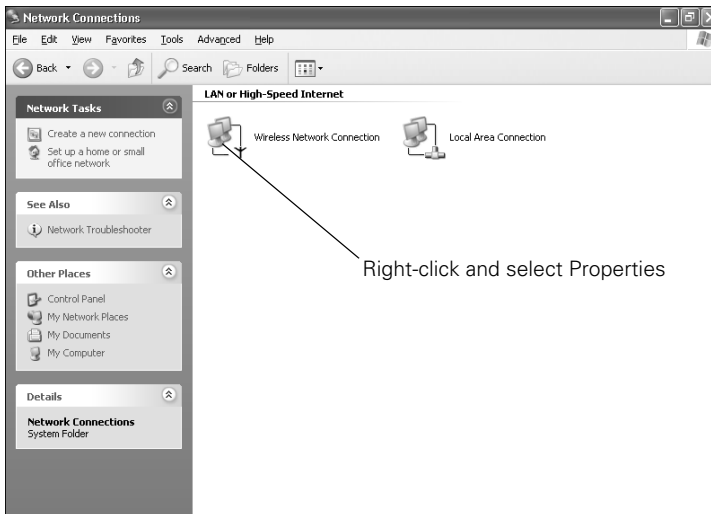

- Right-click the **Wireless Network Connection** icon and select **Properties**.

---

#### **note**

*On some Windows systems, you can right-click My Network Places or Network Neighborhood on the desktop and select Properties.*

---

You see a screen similar to this:

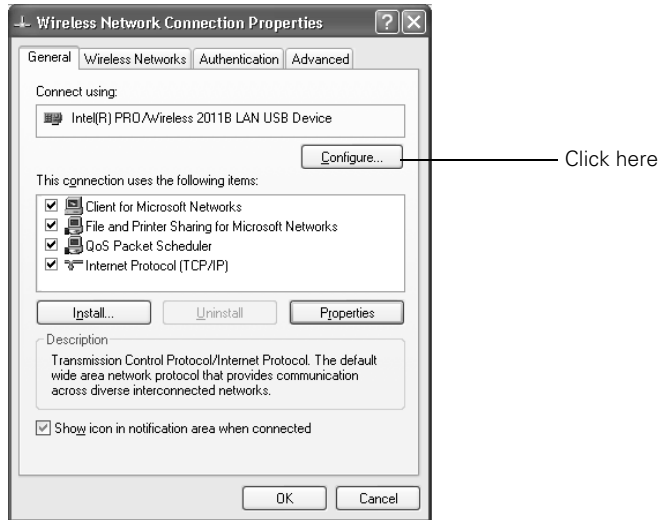

3. Click the **Configure** button.
4. Click the **Advanced** tab. You see a screen similar to this:

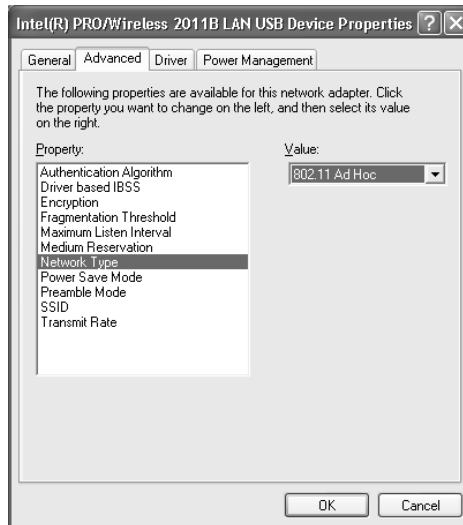

5. Check your wireless card or adapter's device settings. (Depending on the type of card or adapter you're using, some of the settings may be different than those listed here.)
  - Set the network type to **802.11 Ad Hoc**.
  - Set the SSID to match the name you assigned to the projector's ESSID—for example, **CONF ROOM**. (If your network card uses channel mode instead, set the correct channel, 1 to 11, so it matches that of the projector.)
  - Make sure encryption is **Disabled**.
6. Click the **General** tab and make sure that your wireless card or adapter is enabled.
7. When done making the settings, click **OK** to close the wireless card or adapter's -properties dialog box.

Now you're ready to connect to the projector. See "Projecting Wirelessly" on page 89.

### *Setting Up Your Macintosh for Ad Hoc Mode*

Your AirPort software is automatically configured to allow your Macintosh to detect both computer-to-computer (Ad Hoc) and Access Point networks. Typically, you only need to select your projector's ESSID from the AirPort status menu on the Macintosh menu bar.

If you're having problems detecting the projector, follow these steps:

1. From the Apple pull-down menu, select **System Preferences**. Then double-click the **Network** icon. You see the Network settings window.

2. Make sure Location is set to **Automatic**.

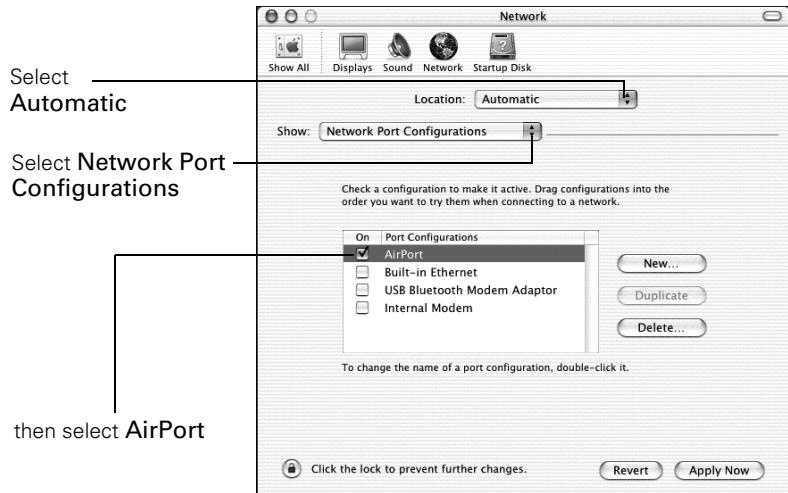

**note:**

*If you don't need the other network ports, disable them by deselecting their check boxes. If more than one network port is enabled, the projector software warns you to turn off AirPort when you first connect the projector. Disregard this message.*

3. Select **Network Port Configurations** in the Show pull-down menu.
4. Under Port Configurations, select **AirPort**.
5. Click **Apply Now**. Then close the window.
6. Click the AirPort icon on the menu bar at the top of the Macintosh desktop. You see the AirPort status menu:



7. Check to make sure AirPort is turned on.
8. Select your projector's ESSID.

## Using Access Point Mode

In order to use Access Point (infrastructure) mode, first adjust your projector and wireless access point or AirPort base station settings as described in this section.

### Configuring the Projector

1. Switch the projector to EasyMP and insert the EPSON 802.11b card (see page 68). You see this screen:

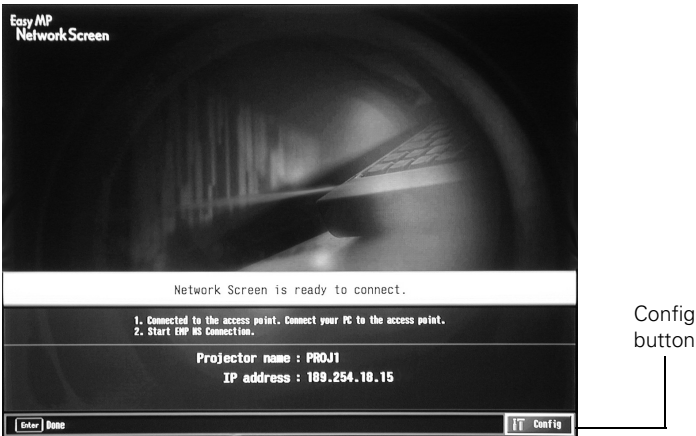

2. To select **Config**, press the **Enter** button on the remote control.

You see the following screen:

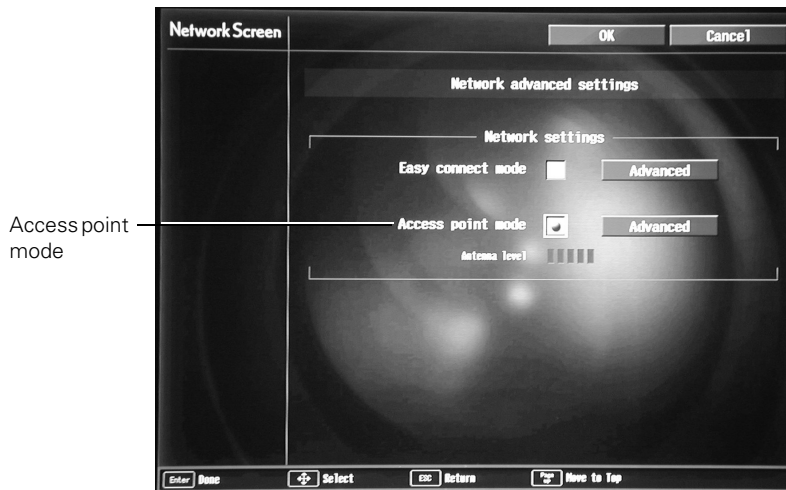

Make sure **Access point mode** is selected, as shown. If not, use the  button on the remote control to highlight the checkbox next to **Access point mode**, then press **Enter** to select it.

- Use the  button to highlight **Advanced** (next to **Access point mode**), then press **Enter** to select it.

You see this screen:





- Make sure the projector has a unique name, so you can identify it when connecting to it from your computer.

### **note**

*If you want to enter a blank space, use the space character that comes before the capital letter A.*

*If you want to enter numbers, press the **Num** button on the remote control. The button lights up to indicate that the numeric keypad mode is active. Press the **Num** button again to exit numeric keypad mode.*

If you need to rename it, highlight the **Clear** button next to **Projector name**, then press **Enter** on the remote control to clear the text box. Then highlight the text box and press **Enter**. The cursor turns green to indicate you are in input mode. Tilt the  button up to select individual letters in alphabetical order, or down to select letters in reverse order; then tilt the  button to the right to move to the next character position. When done typing the new name, press **Enter**.

5. To enable your computer to find the projector on the network, you need to enter the ESSID, which is the SSID identifier of your access point or the name of your AirPort network. (The name of your AirPort network may be different than that of your AirPort base station; select your base station in the AirPort Admin utility and click **Configure** to check the name of your network.) Highlight **ESSID** on the projector screen and press **Enter**. Then enter your access point's SSID identifier or your AirPort network name in the text box. Note that the ESSID is case-sensitive.
6. If you want to create a password for remote access to the projector, type it in the box next to **Password for WEB control** and press **Enter**.
7. If you want to set up a security keyword so that only people who are in the same room as the projector can access it, turn **Projector keyword** on. Then when you want to connect to the projector, it displays a randomized four-digit number or "keyword" on the screen. When prompted by NS Connection, you can enter the keyword on your computer to connect (see page 92).
8. If your access point assigns IP addresses automatically, turn on **DHCP**. Otherwise, turn off **DHCP** and enter the following information manually:
  - **IP address:** Type in the IP address you want to assign to the projector. It must be formatted like other addresses on the network; usually the first three segments (XXX.XXX.XXX) match the first three segments of the IP address for your access point or AirPort base station.
  - **Subnet mask:** For example: 255.255.255.000, but this depends on how your network is set up.
  - **Gateway address:** Enter the IP address that was assigned to the access point or AirPort base station when it was set up.
9. If you want to monitor the projector using HP OpenView,<sup>TM</sup> you'll need to enter at least one trap IP address. See Chapter 7 for details on monitoring the projector.

---

**note**

*The projector keyword changes each time you turn the projector off and then on again, or remove and reinsert the 802.11b card. Check the keyword on the EasyMP Network screen whenever you start EasyMP, and enter that keyword on your computer. You can't connect using a previous keyword.*

---

---

**note**

*For specific details about your network, please consult your network administrator.*

*If you don't know your gateway or access point address, see page 86. If you're using AirPort, start the AirPort Admin utility, select your base station and click **Configure**. Then click the **Network** tab to see your base station's IP address.*

---

10. If you want to set up WEP encryption on the projector for additional security of wireless transmissions, click the **WEP** button on the left side of the screen and continue with “Adding WEP Encryption” on page 80. Otherwise, continue with step 11.
11. When done making your settings, highlight the **OK** button at the top of the screen (you can either use the  button on the remote control or press **ESC** to highlight it), then press **Enter**. Highlight the **OK** button again and press **Enter** to return to the main EasyMP Network Screen.

Now you’re ready to set up your computer for wireless projecting. Continue with “Configuring the Network Settings for Windows” on page 81, or go to “Setting Up Your Macintosh for Access Point Mode” on page 87.

### **note**

*For instructions on how to access the Access point mode advanced settings screen, see page 77.*

### **Adding WEP Encryption**

When you click the **WEP** button on the Access point mode advanced settings screen, you see this screen:



1. If you want to enable WEP encryption, highlight either **128Bit** for 128 bit WEP encryption, or **40Bit** for 40 bit WEP encryption. Then press **Enter**.
2. For **Format**, highlight **HEX** to enable hexadecimal input, then press **Enter**.



3. For Key ID, highlight any of the options and press **Enter** if you're using 40 bit WEP encryption. (This option is not available for 128 bit WEP encryption.)
4. Highlight the **Encryption key** text box and press **Enter**. The cursor turns green to indicate you are in input mode. Check with your network administrator for directions on entering a key for your network, and follow these general guidelines:
  - For 128 bit WEP encryption with hexadecimal input, enter 26 characters, from 0 to 9 and from A to F.
  - For 40 bit WEP encryption with hexadecimal input, enter 10 characters, from 0 to 9 and from A to F.
  - For 128 bit WEP encryption with text input, enter 13 letters of the alphabet.
  - For 40 bit WEP encryption with text input, enter 5 letters of the alphabet.
5. When done making your settings, highlight the **OK** button at the top of the screen and press **Enter**. On the next screen, highlight the **OK** button again and press **Enter** to return to the EasyMP Network Screen.

Continue with the section below to set up your Windows computer for wireless projecting, or go to “Setting Up Your Macintosh for Access Point Mode” on page 87.

### *Configuring the Network Settings for Windows*

Before connecting to the projector, you need to make sure the settings for your computer's wireless card or adapter match the settings you entered for the projector.

1. Access your wireless network Properties window. For example, in Windows XP you would click **Start > Control Panel > Network and Internet Connections**. Then click the **Network Connections** icon.

---

#### **note**

*To enter numbers with the remote control, press the Num button. When it lights up, numeric keypad mode is active. Press the Num button again to exit numeric keypad mode.*

*Text input for WEP encryption varies with different access points; check with your network administrator. Try Text1 first. If that doesn't work, try Text2 and then Text3.*

---

You see a screen similar to the this:

**note**

*On some Windows systems, you can right-click My Network Places or Network Neighborhood on the desktop and select Properties.*

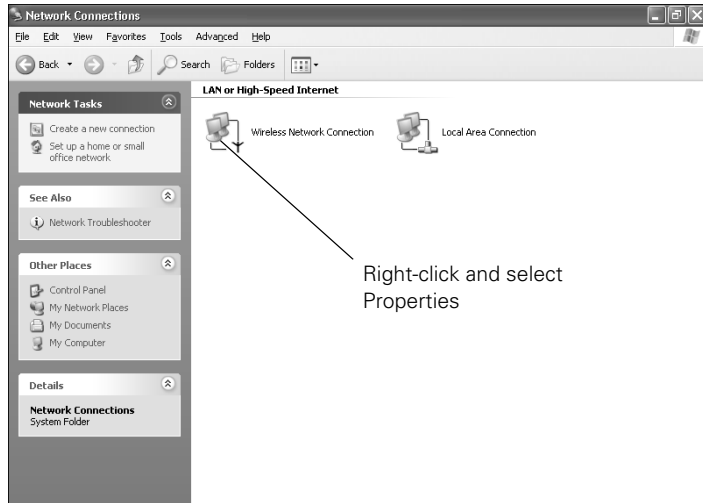

2. Right-click the **Wireless Network Connection** icon and select **Properties**.

You see a screen similar to this:

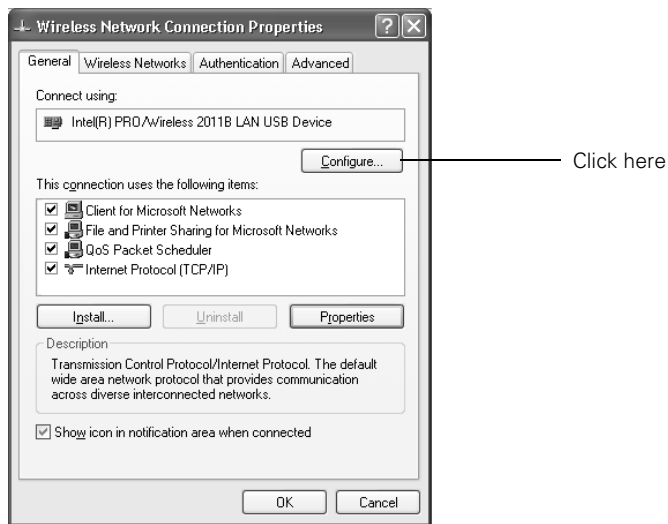

3. Click the **Configure** button.

4. Click the **Advanced** tab. You see a screen like this:

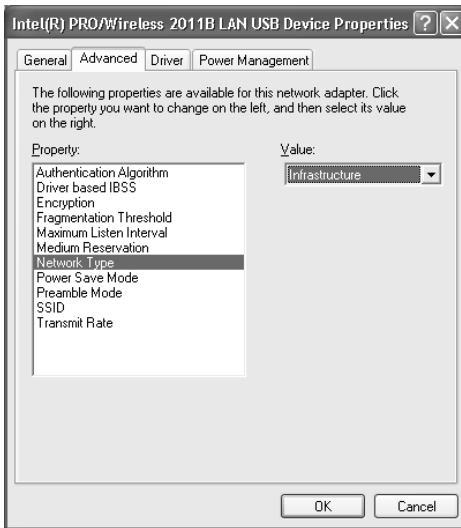

5. Check your wireless card or adapter's device settings. (Depending on the type of card or adapter you're using, some of the settings may be different than those listed here.)
  - Set the network type to **Infrastructure**.
  - Set the SSID to match the name assigned to the access point (which should also be the projector's ESSID)—for example, **CONF ROOM**.
  - Make sure encryption is **Disabled**.
6. Click the **General** tab and make sure that your wireless card or adapter is enabled.
7. When done making the settings, click **OK** to close the wireless properties dialog box.

8. Right-click the **Wireless Network Connection** icon again and select **Properties**. You see this screen:

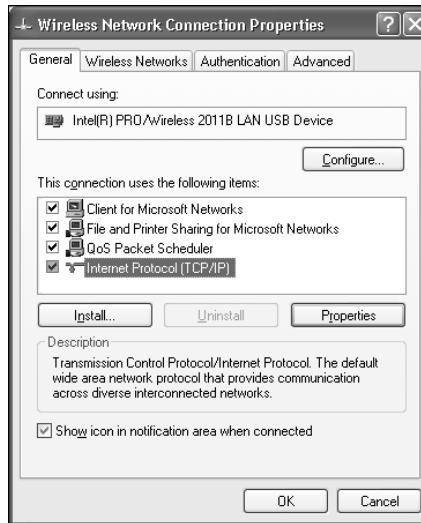

9. Select **Internet Protocol** as shown above, then click the **Properties** button.

You see this screen:

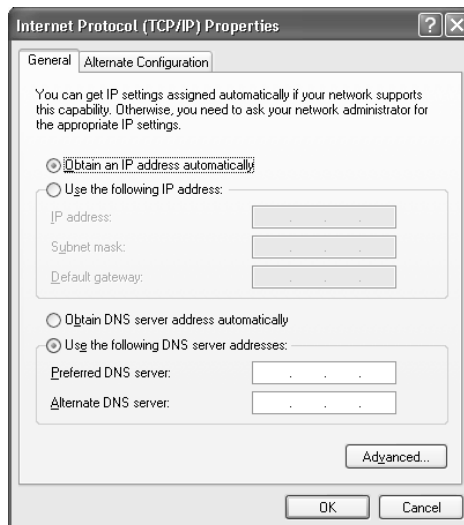

10. If your access point uses DHCP, select **Obtain an IP address automatically**. Otherwise select **Use the following IP address** and enter the required information:

- **IP address:** Type in the IP address you want to assign to the computer. It must be formatted like other addresses on the network; usually the first three segments (XXX.XXX.XXX) match the first three segments of the access point's IP address.
- **Subnet mask:** For example: 255.255.255.000, but this depends on how your network is set up.
- **Default gateway:** Enter the IP address that was assigned to the access point when it was set up.

11. When done making these settings, click **OK**.

12. Click the **Wireless Networks** tab.

(If you don't see this tab, you may need to enable your wireless card or adapter by clicking **Configure** to access the device settings; then follow any instructions on the screen to enable the device.)

Once you click the **Wireless Networks** tab, you see this screen:

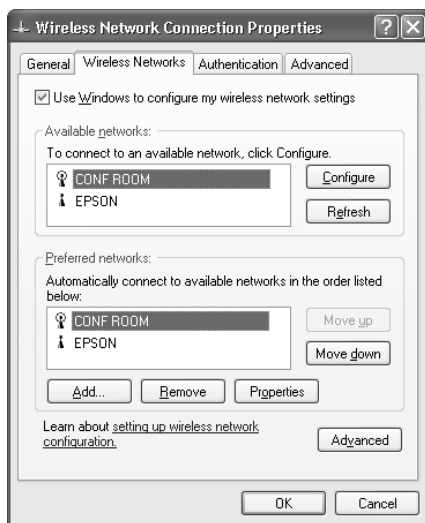

### **note**

*For specific details about your network, please consult your network administrator.*

### **note**

*If you don't know your gateway or access point address, see page 86.*

13. Verify that you've enabled your computer's connection to the access point. It should be listed as shown above, with the small  icon next to it, indicating a connection.

If it's not listed, click **Configure** and then type the name of your access point.

14. When done making your settings, click **OK** to close the dialog box.

Now you're ready to connect to the projector. See "Projecting Wirelessly" on page 89.

### *Checking the Gateway IP Address on Windows*

If you're entering IP addresses manually and need to find out the gateway IP address (the IP address of your access point), make sure the wireless connection to the access point is currently active, as described in the previous section. Then follow these steps:

1. Access your wireless network Properties window. For example, in Windows XP you would click **Start > Control Panel > Network and Internet Connections**. Then click the **Network Connections** icon.

You see a screen similar to this:

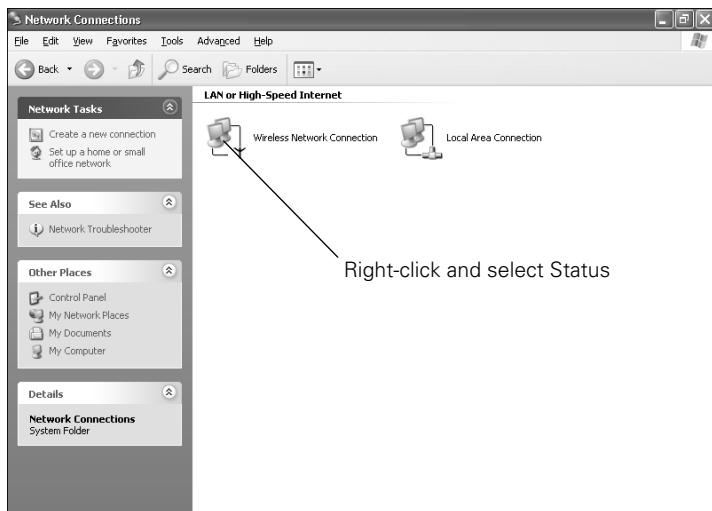

#### **note**

*If you cannot identify the gateway address using this Windows utility, use the administrator's utility software that came with your access point.*

2. Right-click the Wireless Network Connection icon and select **Status**. Then click the **Support** tab.

The gateway's IP address is listed as shown:

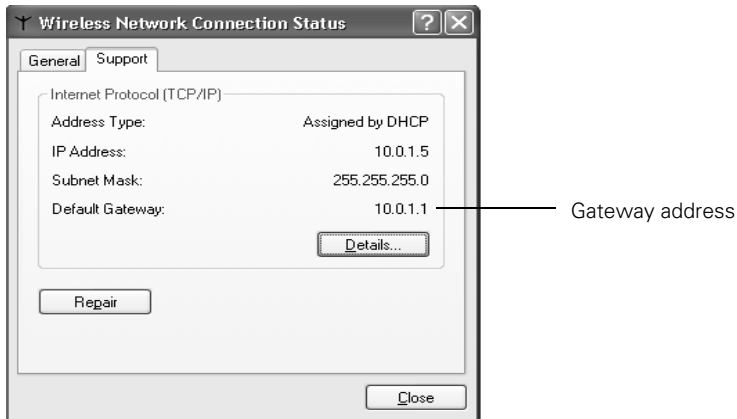

### *Setting Up Your Macintosh for Access Point Mode*

Your AirPort software is automatically configured to allow your Macintosh to detect Access Point networks. Typically, you need only select your AirPort network name from the AirPort status menu on the Macintosh menu bar.

If you're having problems connecting to the projector, follow these steps:

1. From the Apple pull-down menu, select **System Preferences**. Then double-click the **Network** icon. You see the Network settings window.

2. Make sure Location is set to **Automatic**.

**note:**

If you don't need the other network ports, disable them by deselecting their check boxes. If more than one network port is enabled, the projector software warns you to turn off AirPort when you first connect the projector. Disregard this message.

Your AirPort network and base station names may be different. To check or change your AirPort network name, start the AirPort Admin utility, select your base station, and click **Configure**. Click **Show All Settings**, then make any changes you want on the AirPort tab.

If you're connecting to your projector in static IP mode, deselect the **Distribute IP addresses** check box. Make sure your projector's gateway address is identical to the base station's IP address, and the first three segments of the projector's IP address are identical to the first three segments of the base station's IP address.

Select **Automatic**  
Select **Network Port Configurations**

then select **AirPort**

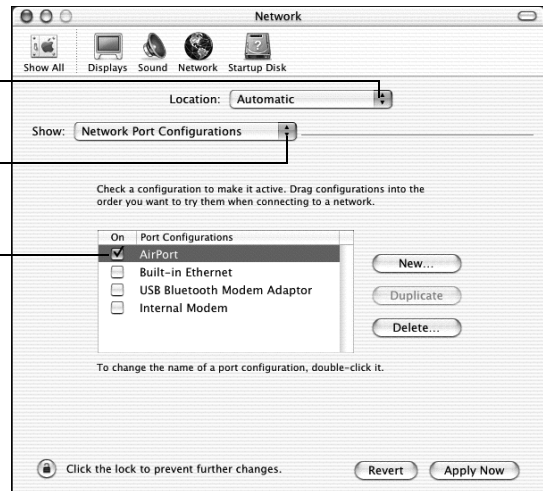

3. Select **Network Port Configurations** in the Show pull-down menu.
4. Under Port Configurations, select **AirPort**.
5. Click **Apply Now**. Then close the window.
6. Start the AirPort Admin utility. Select your base station, then click **Configure**.
7. On the AirPort tab, make sure your AirPort network name matches your projector's ESSID. If not, enter the projector's ESSID in the AirPort Network text box and click **Update**.
8. If you turned DHCP on in your projector's advanced menu, click the Network tab and make sure the **Distribute IP addresses** check box is selected. If you need to select it, click **Update**.



9. Click the AirPort icon on the menu bar at the top of the Macintosh desktop. You see the AirPort status menu:



10. Check to make sure AirPort is turned on.
11. Select the name of your AirPort network.

## *Projecting Wirelessly*

Once you've started EasyMP and set up your projector and computer in either Ad Hoc mode or Access Point mode, follow these steps to start NS Connection and project wirelessly.

1. Make sure you've installed your wireless 802.11b card (see page 68).
2. **Windows:** Select **EMP NS Connection** from the Start menu.

**Macintosh OS X:** Double-click the **EMP NS Connection** icon in your Applications folder.

## note

If you don't see your network adapter's IP address, allow a minute for it to appear. If your access point or AirPort base station uses DHCP (Distribute IP addresses setting is enabled for AirPort), sometimes it takes a minute for the server to pick up the IP address.

Once you've selected the IP address for your network adapter, you won't see the Switch network dialog box when you start NS Connection. If you want to change to a different network adapter, click **Extension** on the EMP NS Connection dialog box, then click **Switch LAN** on the extension dialog box.

The first time you start NS Connection, you may see a dialog box asking you to select your network. Select the IP address for your computer's network card and click OK.

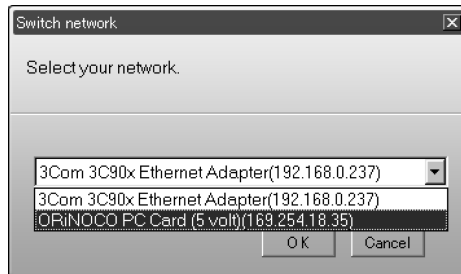

You see the screen below. (If you have previously started NS Connection, this is the first screen you see.)

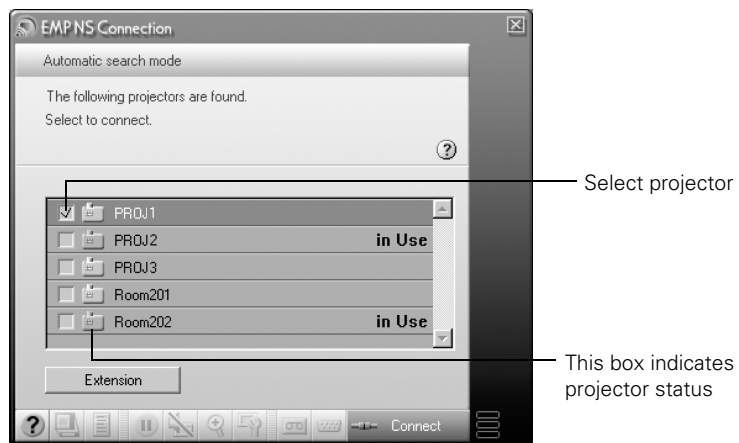

If the connection is working properly, you see your projector listed. If you have additional EPSON projectors on the network, they are also listed, along with their status.

The color of the status icon next to each projector's name indicates its status:

- Gray: the projector is not connected
- Orange: the projector is connected to another computer
- Green: the projector is connected to your computer.

3. If you don't see your projector, check the following:

- Make sure your wireless signal is strong enough to establish a connection. If you have a Macintosh, check the AirPort icon on the Macintosh menu bar. For Windows, see the documentation for your access point or computer network card.
- Make sure you're trying to connect to the right network. In Windows, verify that you've enabled your computer's connection to the access point or that your wireless card or adapter is enabled, and that its SSID matches the projector's ESSID. In Macintosh, check the AirPort status menu (click the AirPort icon on your menu bar) to make sure AirPort is turned on and the projector's ESSID or your AirPort network is selected.
- Make sure you aren't projecting one of the EasyMP configuration screens. (You should see a message that the projector is ready to connect.) If you have to exit a configuration screen, restart NS Connection.
- Make sure the ESSID for your projector matches the SSID for your wireless card, adapter, or access point. If you have an AirPort base station, make sure the projector's ESSID matches the AirPort network name. Remember that the ESSID is case-sensitive.
- Check the IP address for both your projector and your wireless card, adapter, access point, or AirPort base station. The first three segments of the IP address should be identical. The last segment of the projector's IP address should be close, but not identical, to the last segment of the IP address for your wireless interface, access point, or base station.
- Restart your computer and start NS Connection again.
- If you still don't see your projector, follow the instructions in "Connecting in IP Connect Mode" on page 95 to connect to the projector.

---

**note**

*If none of these suggestions work, see the troubleshooting information beginning on page 186.*

---

---

**note**

*The AirPort network name may be different than the AirPort base station name. To check the network name, start the AirPort Admin utility, select your base station, and click **Configure**. Then click **Show All Settings**. The network name appears on the AirPort tab.*

---

---

**note**

*If you want your presentation encrypted, click **Extension** and select **Use encrypted communication**. This step enhances security but decreases the data transmission speed.*

---

4. Once the name of your projector appears, select it and click **Connect**. If more than one projector is listed, you can select additional ones to connect to them at the same time. If the selected projector is already being used by another person, you can still connect to it; doing so automatically disconnects the other user.
5. If you set up the projector to prompt you for a keyword before connecting, you see a screen like this one:

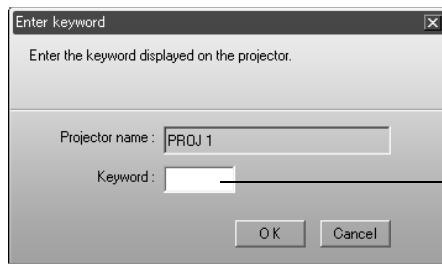

Enter keyword

Type in the four-digit number displayed on the EasyMP Network screen and click **OK**.

6. Once the connection is established, you see your computer's image transmitted to the projector, and a floating control bar:



Click here to minimize

7. If necessary, drag the control bar out of the way, or minimize it to an icon on the taskbar by clicking it as shown above.

8. From the control bar, you can access these NS Connection features:



Provides help for NS Connection.



Lists projectors and specifies which ones are in use.



Lets you access the projector's menu system from an HTML browser window. See page 156 for more information.



Lets you keep the projected image on screen, even if the image on your computer changes.



Turns off the image and sound.



Lets you zoom in on a part of your image.



Lets you change the brightness, keystone angle, contrast, color mode, and other basic settings.



Lets you switch between the Video, S-Video, and BNC ports.



Lets you switch between signals from the Computer and DVI ports.



Flashes three lights in sequence when the computer and projector connection is active.

9. When done with your presentation, click **Disconnect** on the control bar.

## Using the Control Bar

Clicking one of the buttons on the control bar may cause a submenu to appear above the control bar. For example, clicking the  button displays the following submenu:

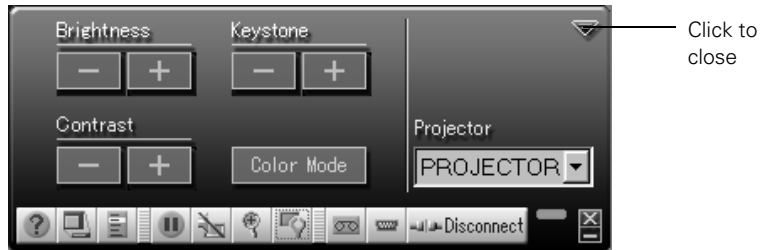

If you are using more than one projector, you can use the **Projector** drop-down menu to select the projector to which you want to make any of the following changes:

- **Brightness**  
Increase or decrease brightness
- **Keystone**  
Click + to narrow the top edge of the screen, or - to narrow the bottom edge (this option functions like the **Sync** buttons on the projector's control panel)
- **Contrast**  
Increase or decrease image contrast
- **Color Mode**  
Lets you select from five preset modes to adjust the color and brightness for specific environments: **sRGB** for computer displays (the default when projecting from a computer with analog video), **Dynamic** for presentations in bright rooms, **Presentation** for presentations in dark rooms, **Theatre** for optimizing movie images (the default for video display), and **Living Room** for video games

When you're done making changes, click the arrow in the upper right corner to close the menu.

## Connecting in IP Connect Mode

Even if your projector and computer are on a different subnet (Access Point mode only) or connecting over different routers, you can establish a connection manually using IP Connect Mode.

1. Start NS Connection on the computer to which you want to connect. You see this screen:

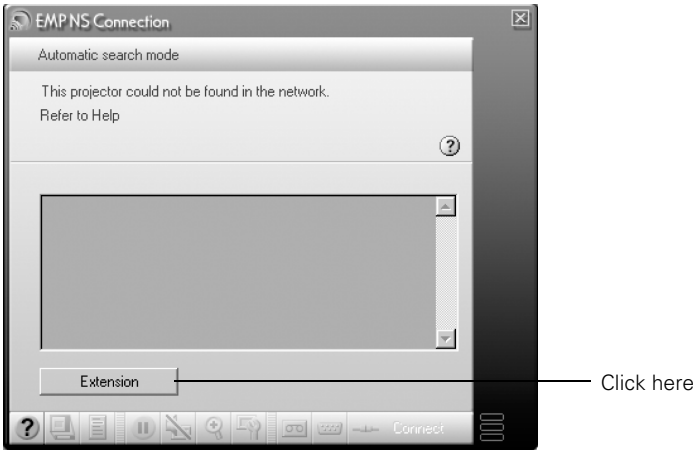

2. Click the **Extension** button. You see this screen:

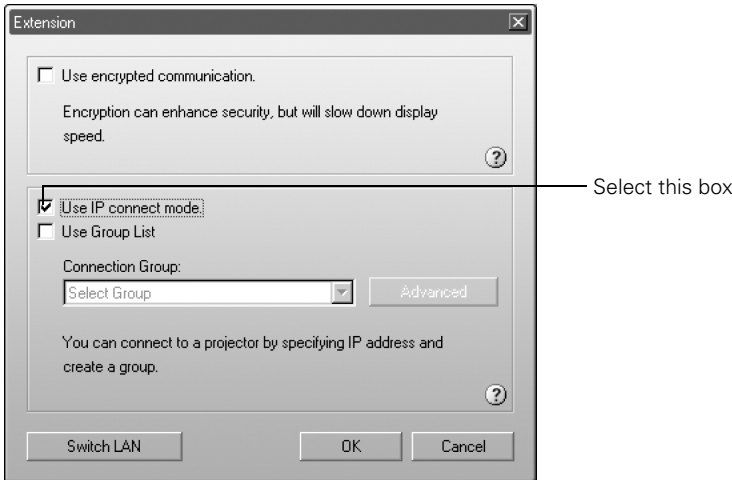

---

### **note**

*Depending on your network, your projector and computer may connect over different routers even if they are in the same room. Try this method if you are unable to connect automatically.*

---

3. Select **Use IP connect mode** and click **OK**. You see this screen:

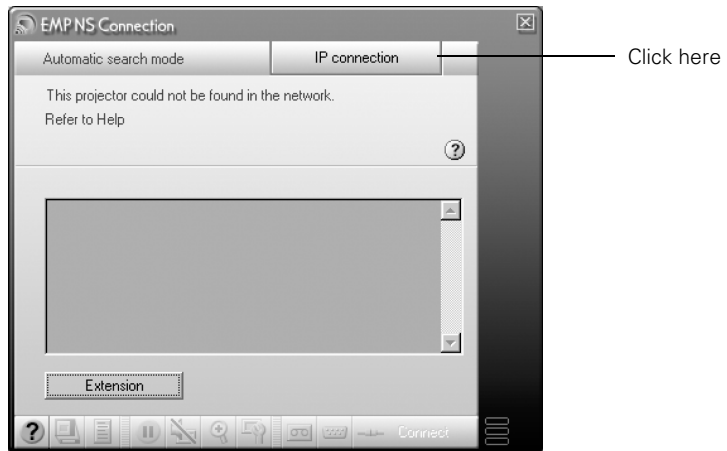

4. Click **IP connection**. You see this screen:

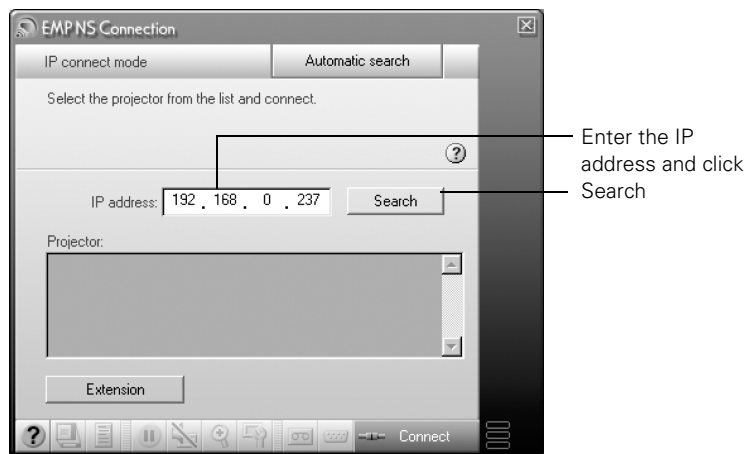

---

**note**

*You can add up to 16 projectors to the list. If you add more, NS Connection begins to delete projectors from the list, starting with the first projector added.*

---

5. Enter the projector's IP address and click **Search**.



The IP address appears in the Projector list and a  searching icon displays:

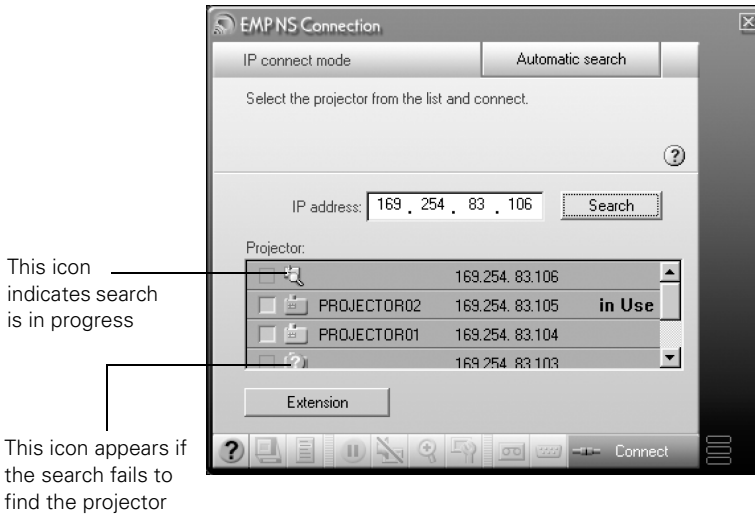

If the search fails to find a projector with the specified IP address, the searching icon turns into a question mark. If this happens, run EasyMP to check the projector's IP address, then repeat this step.

6. Click the projector you want to connect to, then click the **Connect** button. If more than one projector is listed, you can select additional projectors and connect to them at the same time.
7. If you are prompted for a keyword, enter the four-digit number displayed on the EasyMP Network screen and click **OK**.

The computer's image is transmitted to the projector. See page 92 for details about using the floating control bar.

---

### **note**

*You can connect to a projector while another person is using it. Follow the steps on page 98.*

---

## Switching Between Users

To connect to the projector while another person is already using it (Access Point mode only), you follow the same basic steps as described in the previous section.

1. Start NS Connection. You see this screen:

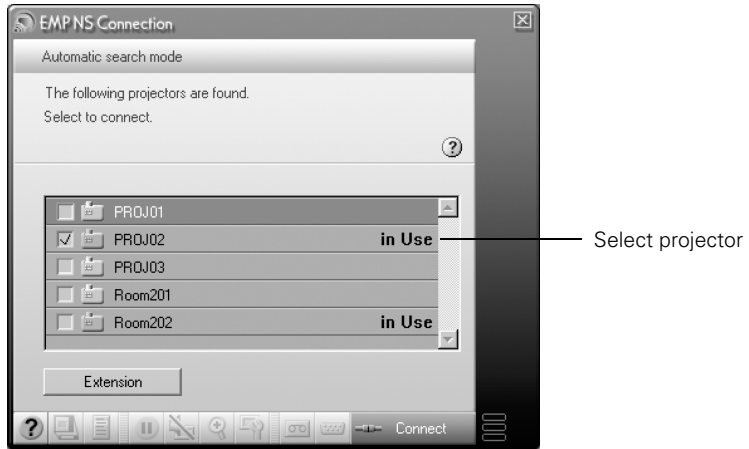

2. Select the projector and click **Connect**.

You see this message:

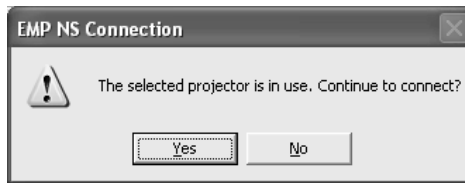

3. Click **Yes** to connect.

The other user is automatically disconnected and notified about the interruption:

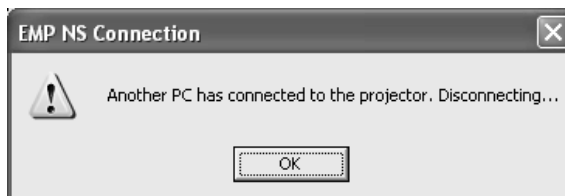

## Removing the Wireless 802.11b Card

Follow these steps to remove the card.

1. If you're running NS Connection, click **Disconnect** on the control bar.

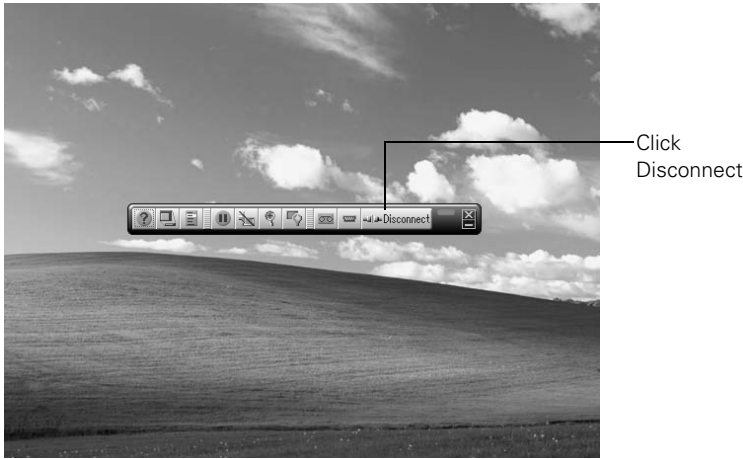

2. Check the card indicator light to make sure it isn't flashing or on. Then press the eject button. The button pops out.

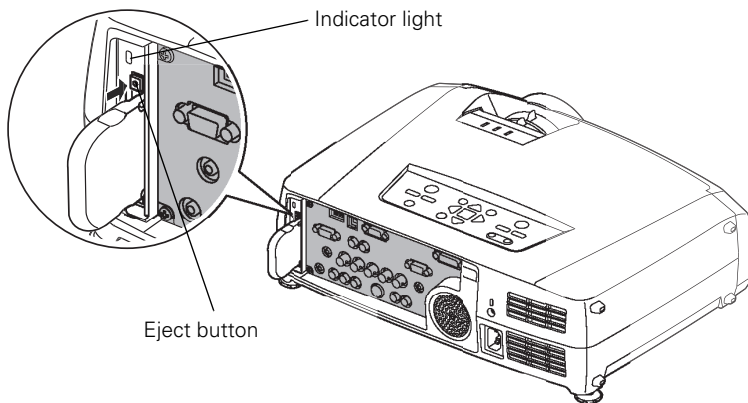

3. Press the eject button again. The wireless card partially ejects.
4. Pull the card straight out. Then press the eject button back in to prevent it from being damaged.

### **caution**

*Never remove the card while the card indicator light is green, or when projecting wirelessly. You may damage the card or lose data.*



# 5

## *Presenting from a Memory Card or Digital Camera*

The projector's EasyMP feature lets you give presentations from a memory card or a digital camera connected to the projector with a USB cable. You can play movies, display graphics, or play a *scenario*, a format that lets you create your own slideshow using PowerPoint files, JPG image files, and BMP graphics files.

This chapter includes instructions for the following:

- Creating a scenario
- Transferring your scenario to a memory card
- Inserting the memory card in and removing it from the projector
- Presenting scenarios
- Creating a slideshow on the fly
- Presenting image files on a digital camera

Before starting, make sure you've installed the EMP SlideMaker software as described in Appendix A.

---

### **note**

*To create a scenario, you'll need a memory card and a card reader on your computer. Depending on the type of card, you may also need an adapter to use it with the projector. See page 111.*

---

## Creating a Scenario

### **note**

*Before starting, make sure you've installed EMP SlideMaker as described in Appendix A.*

A scenario is a combination of images, movies, and/or audio files that you can present from a memory card. The easiest way to create a scenario is to drag and drop a PowerPoint file on the  EMP SlideMaker2 icon on your desktop. This automatically converts the file, which you can save to the memory card. Use this method if you have an existing PowerPoint presentation that you want to transfer to the projector.

If you prefer, you can create a scenario from scratch by combining a selection of PowerPoint slides, other graphics, and even movies (see page 104).

### **Converting a PowerPoint File to a Scenario**

Follow these steps to convert a PowerPoint file to scenario. Once the scenario is created, you can add transitions as described on page 108.

1. Locate the PowerPoint file you want to use in My Computer or Windows Explorer.
2. Make sure the EMP SlideMaker program is closed. Then drag the file icon on top of the  EMP SlideMaker2 icon on your desktop.
3. You see a message that some transitions are not supported. Click OK.

EMP SlideMaker starts, and your PowerPoint slides open one-by-one as they are converted. Do not interrupt this process, or your PowerPoint file won't be completely converted.

- When you see a message that the slideshow is complete, left mouse-click or press **Enter** as prompted. You see your scenario as shown below. The scenario is made up of individual cells for each of the PowerPoint slides.

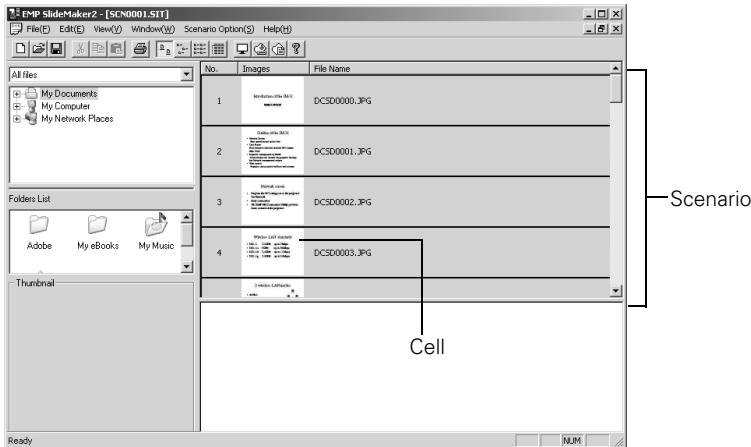

- At this point, you can insert additional images or create transition effects between slides. (See the instructions for “Building a Scenario from Different Files” on page 106 and “Setting Up Transitions” on page 108 for details.)

If there are slides in the scenario that you don’t want to use, right-click those cells and select **Inactivate**.

- Click the **Save** button or choose **Save** from the File menu.

EMP SlideMaker automatically names your scenario (SCN\_\_\_\_) and creates a folder for it within your **Program Files\EMP SlideMaker2** folder. However, you can choose **Save As** from the File menu and enter a new scenario name and folder location if you want.

Once your scenario is saved, you can transfer it to the memory card in your computer’s PCMCIA slot (see page 111).

**note**

*You have to save the scenario on your computer’s hard drive before transferring it. Don’t save it directly to the memory card, or it may not play correctly.*

## Creating a Scenario from Scratch

Use this method when you want to create a new scenario from a selection of PowerPoint slides, images, or movie files.

1. To start the software, double-click the  EMP SlideMaker2 icon on your computer's desktop (or click **Programs** or **All Programs** > **EPSON Projector** > **EMP SlideMaker2** from the Start menu).

You see the EMP SlideMaker screen:

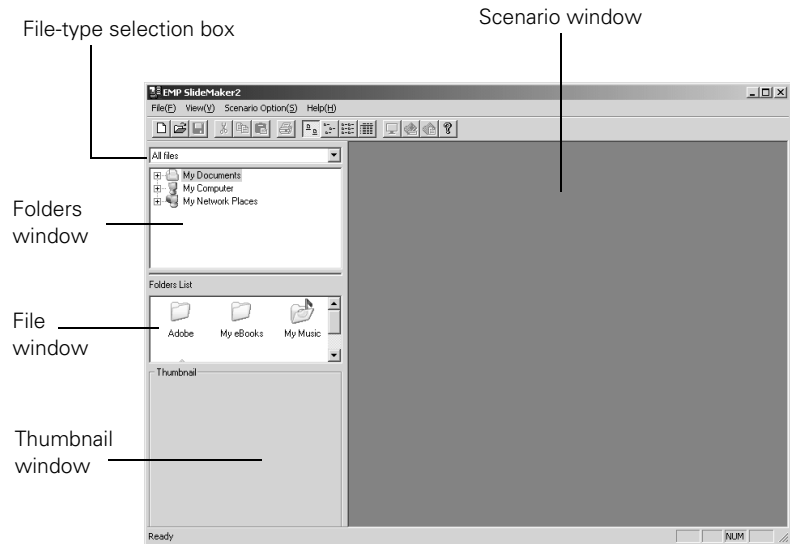



2. Choose **New** from the File menu. You see the scenario Properties dialog box:

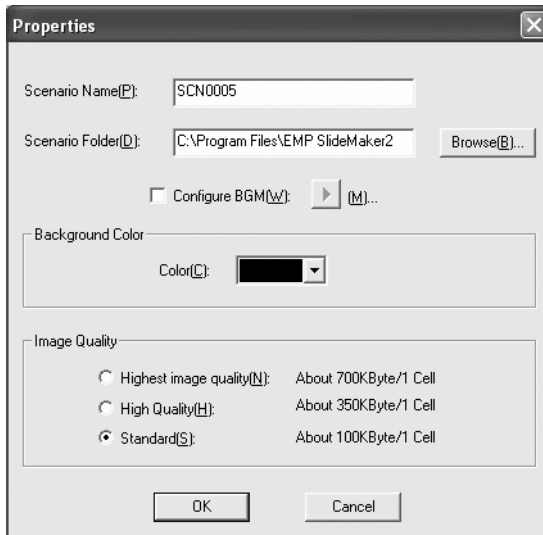

3. Type a name for your scenario that's easy to remember, using up to eight capital letters and numbers. Then select from the following options:
  - The default location for the scenario file and folder is in the \Program Files\EMP SlideMaker2 folder. Click **Browse** to choose a new location.
  - Click **Configure BGM(W)** to play an audio file during the scenario. A selection screen appears letting you choose the .WAV file. After you select the file you want, click the arrow button to the right of this option to play it.
  - The background color appears around images that don't fill the entire screen area. Select a new color, if desired.
  - Select the image quality for imported PowerPoint slides. Higher-quality images look better on the screen but may take longer to appear.
4. Click **OK** when you're finished making these settings.

Continue with the instructions in the next section to build your scenario.

---

**note**

*The scenario name you enter is also the name of the folder for your scenario on your hard drive.*

---

## Building a Scenario from Different Files

You can build your scenario from any of the following file types, either alone or in combination with other file types:

- PowerPoint slides, version 2000 through 2002 (file names have .PPT extension)
- JPEG files (with .JPG extension)
- Bitmap files (with .BMP or .DIB extension)
- Movie files (with .MPG extension); must be MPEG 2; MPEG1 is not supported

Follow these steps:

1. Use the navigation tools on the left side of the EMP SlideMaker screen to locate the files you want to include in your scenario.

PowerPoint, JPEG, bitmap, and movie files appear as icons in the file window.

### note

You can also use the instructions in this section to add files to an existing scenario.

### note

Thumbnail previews for PowerPoint slides will not appear if PowerPoint is not installed on your computer.

Click to see preview

Thumbnail preview

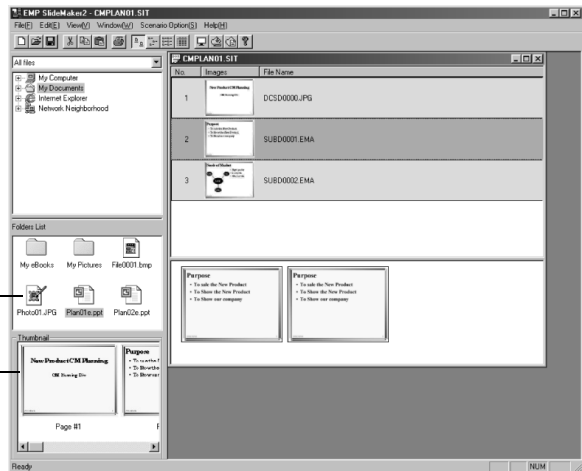

2. Click the icon for each file that you want to preview in the thumbnail window. If you click a PowerPoint icon, thumbnail images are generated for all the slides in the PowerPoint file. If you click a movie file, an illustration of a film strip appears in the thumbnail window.

3. Drag and drop the files you want to use from either the file window or thumbnail window into the scenario window. (You can also double-click a thumbnail to add the file to the scenario.)

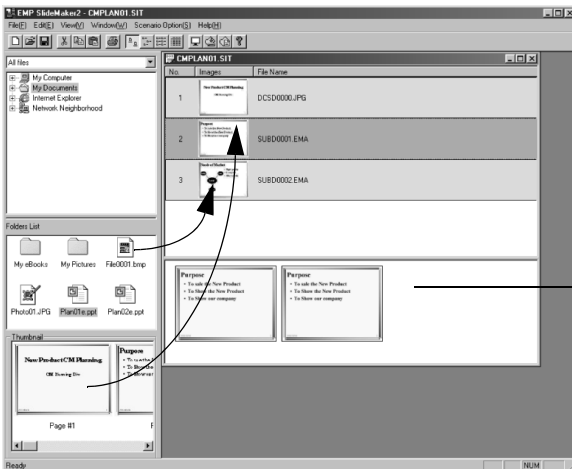

Check a slide's animation effects here

- To include a whole PowerPoint file (instead of individual slides), drag the PowerPoint icon itself into the scenario window. Dragging an entire file preserves the transitions set in PowerPoint.
4. Continue dragging files into the scenario window to build your presentation. Each slide appears in a numbered cell. The cell background color varies according to the type of file in the cell.
  5. If you want, you can make changes to the scenario:
    - To rearrange cells, drag and drop them as necessary within the scenario window.
    - To delete a cell, right-click the cell and select **Cut**.
    - To check the animation for a slide, click its cell. A section appears at the bottom of the scenario window displaying each animation operation. (Slides using animation have an .EMA extension.)

You can also create transitions between slides, as described in the next section.

### **note**

*Transition effects created in PowerPoint look smoother than those you add with SlideMaker.*

### **note**

*Unless you change the transition setting, your slides will automatically advance after 30 seconds by default.*

- When you're done, click the **Save** button or choose **Save** from the File menu. Then see page 111 to transfer the scenario to your memory card.

## Setting Up Transitions

EMP SlideMaker lets you set your slides to advance manually or automatically after a specified period of time. You can also choose from a variety of transition effects between slides.

- Click the cell or cells you want to set up in the scenario window.

To select more than one cell, hold down the **Ctrl** key while you click. To select all the cells, choose **Select All** from the Edit menu. Selected cells turn yellow.

- Right-click the selected cell or cells. The cell menu appears:

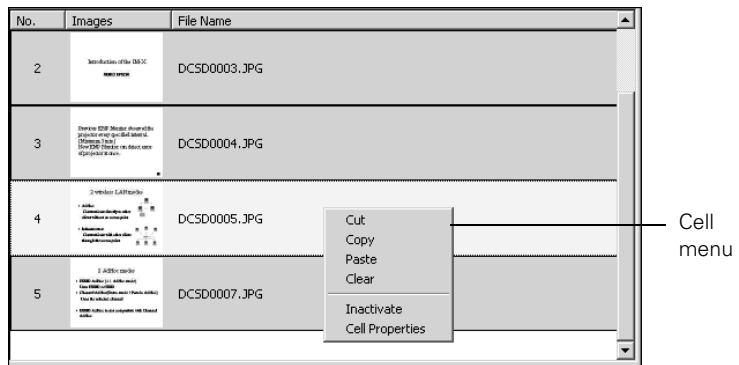

3. Click **Cell Properties**. You see this dialog box:

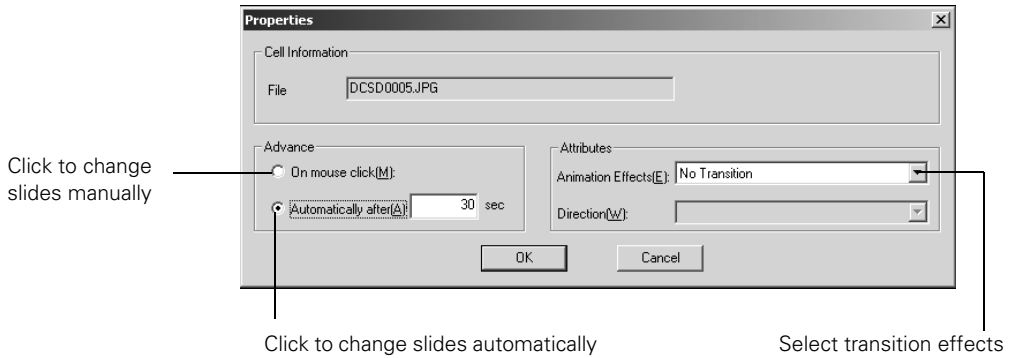

4. Choose how you want to advance to the next cell.

- If you want to change slides manually using the remote control, select **On mouse click**.
- If you want your slides to advance automatically, set the timing in the **Automatically after** box. You can set any length of time between 1 and 1800 seconds (30 minutes). Even if you select this setting, you can still change slides manually using the remote control.

5. To add a transition effect (such as a dissolve, fade, or wipe), select one of the **Animation Effects** and choose a **Direction**, if applicable.

6. When you're finished setting up the transition for the selected cell or cells, click **OK**.

7. Click the **Save** button or choose **Save** from the File menu.

Continue with the steps in the next section when you're ready to transfer your scenario to a memory card.

---

**note**

*Transition effects look smoother when you create them in the PowerPoint file itself and use that file to create a scenario.*

---

## Checking Your Scenario

You can play your scenario before you transfer it to a memory card to make sure it looks and sounds the way you want it to.

1. Start EMP SlideMaker.
2. Use the navigation tools in the folders window to locate the scenario file you want to review. Click the file, then click **File > Open** to open the scenario.
3. Click **Scenario Option(s) > Scenario Preview**. The Scenario Preview window displays.

If your scenario is set to advance automatically (see page 109), it begins to play. If it is set to advance each time you click the mouse, click the  play button to go through your slides one by one.

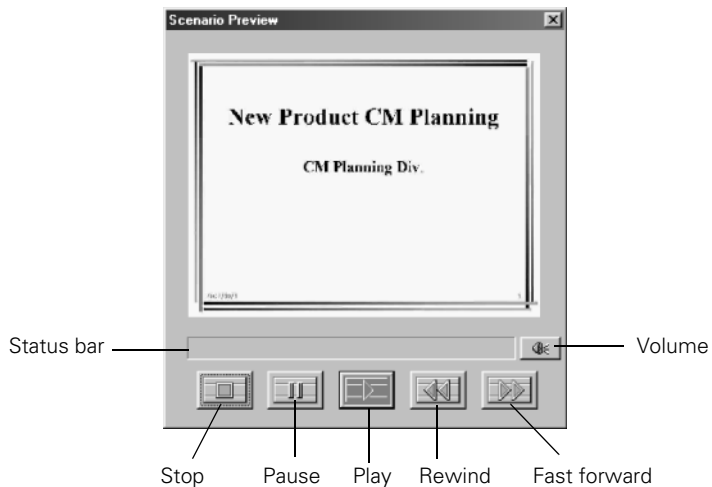

4. Use the controls on the Scenario Preview window to pause, stop, rewind, or fast forward your scenario. When you're done, close the window.

## Transferring Your Scenario to a Memory Card

Once your scenario is saved, you can transfer it to a memory card. You can use any of the following standard Type II cards. Most require a PC card adapter to allow insertion into the projector (check with your computer dealer for availability).

- CompactFlash™
- Memory Stick™
- SmartMedia™
- Microdrive™
- ATA flash (does not require a PC card adapter)

Before you start, make sure you are set up to access the card in your computer's PCMCIA slot or card reader. Be sure to use the transfer process described below to ensure that the scenario plays properly:

1. Insert the memory card in your computer's PCMCIA slot.
2. From the Scenario Option(s) menu, choose **Send Scenario**. You see a drive selection window:

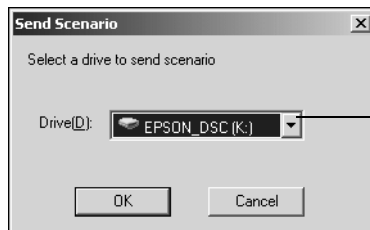

Select your memory card drive

3. Choose the drive where your card is located, then click **OK**.
4. Click **OK** again to confirm. Your scenario is transferred to the card.

Once the scenario is transferred, you see this message about your scenario's autorun setting:

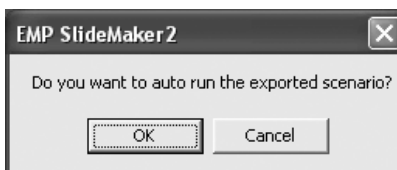

### **note**

*You have to save the scenario on your computer's hard drive before transferring it. Don't use Windows to copy the scenario to your memory card, or it may not play properly.*

*You must insert the memory card in your computer's PCMCIA slot before you select **Send Scenario** from the Scenario Option(s) menu. If you don't, you won't be able to see the card's drive in the drive selection window. If this happens, close and restart EMP SlideMaker. Make sure your card is inserted before you select **Send Scenario**.*

The autorun setting means that the scenario will start playing whenever the projector is turned on (with the memory card in the projector).

5. Do one of the following:
  - If you don't want the scenario to run automatically, click **Cancel**. Skip to step 9 to remove the card and insert it in the projector.
  - If you want it to run automatically, click **OK** and continue with the following instructions.

You see the Edit Autorun window:

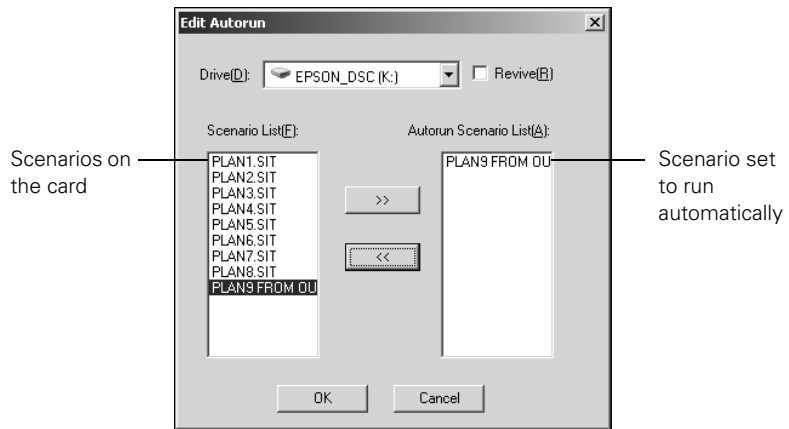

### **note**

*If more than one scenario is set to run automatically, they will play in the order listed on this screen.*

6. To set a scenario to run automatically, select it from the list on the left side of the screen and use the **>>** arrow button to move it to the list on the right.
7. Click the **Revive** box if you want your scenario to repeat continuously. Clear the checkbox if you want it to play only once.
8. When done, click **OK**.
9. Remove the card from your computer. See your computer's documentation if you need instructions on removing the card. If you're using Windows 2000 or Me, you may first need to click an icon to stop or disconnect the card.



## *Inserting the Memory Card in the Projector*

When done transferring your scenario to the memory card, follow these steps to insert it in the projector:

1. If necessary, insert the card into a PC card adapter. (ATA flash cards don't require an adapter.)
2. Insert the card (with the adapter) into the projector with the label facing outward, as shown. The projector does not have to be turned off before inserting the card.

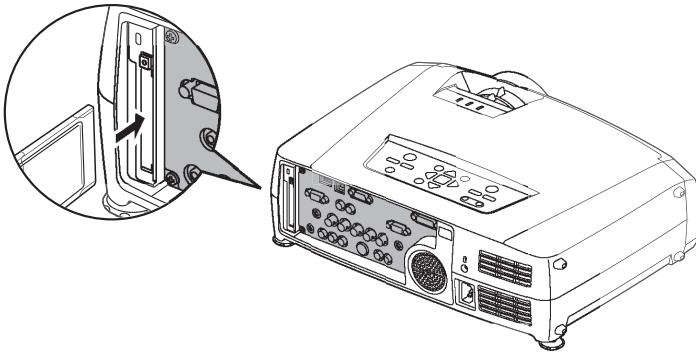
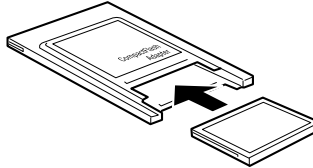

### **note**

*If a digital camera is connected to the projector, disconnect it before inserting the memory card. The memory card is not functional when a digital camera is connected.*

### **caution**

*Never force the card into the slot; you could damage the projector.*

## Removing the Card

### **note**

*If you are using CardPlayer, highlight the EJECT button and press Enter on the remote control. Then wait for the indicator light to go off before you eject the card.*

When you're done using the projector and want to remove the memory card, follow these steps. Make sure a scenario is not playing and the card is not in use (the indicator light above the card slot is off) before removing it.

1. Press the eject button above the card slot.

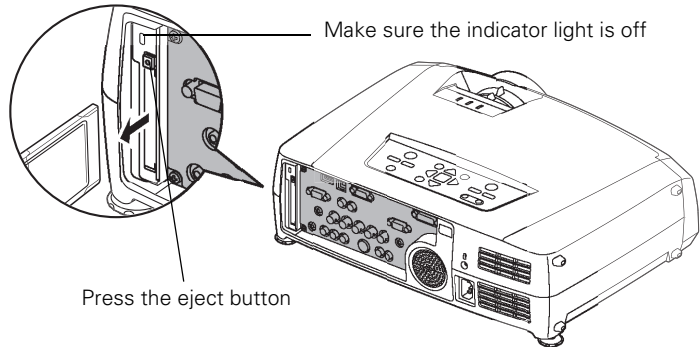

The button pops out.

2. Press the button again. The memory card is released, and you can remove it from the slot in the projector.
3. To remove the card from the adapter, pull it out as shown:

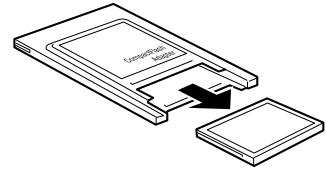

# Presenting Scenarios



Before you begin, insert the memory card as described on page 113.

Follow these steps to present a scenario that you've saved to a memory card:

1. Turn on the projector, if it's not already on.
  - If your scenario is set to autorun, it will start as soon as the projector warms up.
  - If your scenario is not set to autorun, you need to start it manually. Continue with the following steps.
2. Select EasyMP as the source by pressing the **EasyMP** button on the remote control. You see a screen like the one below.

JPEG files are displayed as thumbnails. Other files or folders are displayed as icons. A  scenario icon identifies a scenario file.



3. Use the  button on the remote control to highlight your  scenario file, then press **Enter**. A drop-down menu appears under the scenario.
4. Use the  button to select **Play Scenario**. In a moment, your scenario begins playing.

## note

*You cannot have a digital camera connected while the memory card is inserted. If you do, neither the camera nor the card will function with your projector's software.*

## note

*Your files may take up more than one screen. If so, use the **Page up** and **Page down** buttons on the remote control to view all your files.*

5. When you're done with your presentation, use the  button to highlight EJECT in the upper right corner of the screen, and then press **Enter** on the remote control. When you see a message asking you to insert a LAN card or memory card, it's safe to remove your memory card (see page 114 for details).

## **Controlling Your Presentation**

While your presentation is running, use the remote control as follows:

- Press **Enter** or **Page down** to display the next slide or image, or to begin playing a movie.
- Press **Page up** to display the previous slide or image, or to replay a movie.
- Press different sides of the  button to rotate a slide or image on the screen.
- To exit the scenario at any point, press the **ESC** button. Press the **Enter** button to confirm that you want to exit.

## **Editing Your Scenario on the Projector**

You can modify your scenario using EasyMP on the projector. This lets you make last-minute changes, such as changing the order of your slides or hiding individual slides. These changes are not permanently saved with the scenario, but remain in effect only as long as you don't remove the card or turn off the projector. Follow these steps:

1. Highlight the  scenario you want to edit, then press **Enter**.

---

### **note**

*Even if your scenario is set to change slides automatically, you can still change slides manually as described here.*

---

- From the drop-down menu, select **Edit Scenario**. You see thumbnail images of the slides in your scenario:





- To move a slide, select the slide you want to move and press **Enter**. From the drop-down menu, select **Move Files**. A yellow line (or “I-beam”) appears beside the slide.  
Use the  button to move the I-beam where you want to insert the slide. Then press **Enter**. The slide moves to the new position.
- To hide a slide, select the slide you want to hide and press **Enter**. From the drop-down menu, select **Show/Hide**.  
If you change your mind and want to display the slide again, repeat the process to make the slide visible.
- When done, highlight the **OK** button on the screen and press **Enter**.

## *Creating a Slideshow on the Fly*

If you have a folder on your memory card containing an assortment of images, you can display them as a slideshow. Your options for arranging the slideshow are more limited than when you create a scenario—for example, you won't be able to include PowerPoint slides, just JPG images and bitmaps, and you won't have much control over the order in which they're displayed. However, this method quickly lets you display your images if you don't have time to make a scenario.

### ***Displaying the Slideshow***

First make sure the images are stored in a folder on the memory card. Then follow these steps:

1. Use the  button on the remote control to highlight the  folder containing your images. Then press **Enter**.



2. From the drop-down menu, select **Play Slideshow** and press **Enter**. The images contained in the folder are presented as a slideshow.
3. Use the remote control to run the slideshow in the same way as for a scenario (see page 116).

## Changing Timing and Other Settings

For each folder on the memory card, you can set the display timing for your slides and change several other display settings.

1. Select the  folder whose settings you want to change and press **Enter**.
2. From the drop-down menu, select **Options**.

You see this screen:



3. Use the  button to select from the following settings. After making a selection, press **Enter** to enable the change.
  - **Continuous Play**  
Determines whether to repeat the display of images in the folder.
  - **Screen switching time**  
Sets the display time for each image. Choose **No** if you want to change slides manually.
  - **Display order**  
Choose between displaying alphabetically by file name or by image file date.
  - **Effect**  
Lets you choose from various transitions between slides, such as dissolve or wipe.

- **Mode switching**

Lets you choose the mode to use when presenting slideshows, movies, or images, or editing your scenario on the projector.

In **Guide mode**, which is the default, a drop-down menu appears whenever you select an item and press **Enter**.

In **Quick mode**, selecting a scenario, movie, or image file and pressing **Enter** starts the presentation; selecting a folder and pressing **Enter** opens the folder. To access the menus in **Quick mode**, press the **ESC** key.

4. When you're finished changing the settings, highlight **OK** on the screen and press **Enter**. Your changes are permanently saved with each folder—even if you turn off the projector or remove the memory card.

## *Presenting Image Files on Your Digital Camera*

### **note**

*Most digital cameras also have the ability to play internal slideshows. Depending on the kind of cable you have, you can connect a camera with a video or A/V out port to the projector's Video or S-Video port and transmit your camera's slideshow directly to the projector. You must press the Video or S-Video button on the remote control to select the correct signal source. See pages 59 and 60 for details.*

This section explains how to project individual image files on your digital camera using EasyMP and a USB cable connection.

Before you begin, make sure that there is no memory card in the projector's card slot, and that your digital camera is connected to the computer (see page 64 for details). You cannot have the camera connected while a memory card is inserted; neither the camera nor the card will function with EasyMP.

Follow these steps:

1. Turn on your digital camera.
2. Turn on the projector and the remote control, if they're not already on.
3. Select EasyMP as the source by pressing the **EasyMP** button on the remote control. If your camera complies with the DCIM standard, you'll see a **DCIM** folder.
4. Use the  button on the remote control to position the cursor on the folder, and then press **Enter**.



5. Select **Open Folder** on the drop-down menu. When the folder opens, you see another folder with your manufacturer's name.
6. Position the cursor on the folder and press **Enter**. Then select **Open Folder**.

You see your image files when the folder opens.

7. Position the cursor on the image file you want to project and press **Enter**. Then select **View Image**.

The image is projected on the screen. If you want, you can press different sides of the  button to rotate the image while you're viewing it.

To end projection, press the **ESC** button on the remote control, then select **Exit** and press **Enter**.

---

**note**

*Make sure your camera shows up on your desktop as a drive letter. If it does, it is probably a USB mounted device and will work with the projector software. The EasyMP software does not support TWAIN-compliant digital cameras.*

*If your camera's memory card is supported by the projector, you can insert it into the projector's card slot and project your images (see "Creating a Slideshow on the Fly" on page 118). You can't have your camera connected at the same time.*

---



# 6 *Using the Projector's Menus*

You can use the projector's on-screen menus to adjust the image, sound, and other features. This chapter covers the following information:

- Using the menu system
- Adjusting the image quality
- Adjusting the image size, shape, and position
- Adjusting the color
- Adjusting the sound
- Creating your own startup screen
- Controlling multiple projectors
- Customizing projector features

## Using the Menu System

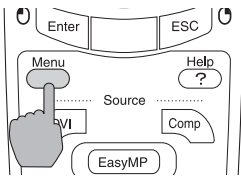

You can use the remote control (or the projector's control panel) to access the menus and change settings. Follow these steps:

1. To display the menu screen, press the **Menu** button.

You see a menu screen similar to the one shown below (the settings may differ from those shown here, depending on the selected input source):

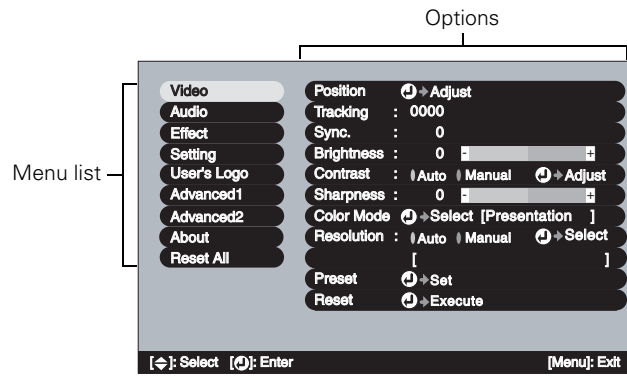



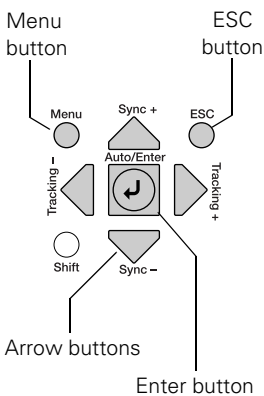

### note

You can also use the buttons on the projector to access the menu system:



The menus are listed on the left, and the options available for the highlighted menu are shown on the right.

2. Use the  pointer button on the remote control (or the arrow buttons on the projector) to scroll through the menu list. When you've highlighted the desired menu, press the **Enter** button to select it.
3. Once you've selected the menu, use the  pointer button to scroll through the list of options. (Some of the options may be grayed out or unavailable, depending on the selected source.)

4. After highlighting the option you want to adjust, use the  pointer button to change the setting. In some cases, you may have to press the Enter button to see a sub-screen for changing the setting.
  - Press the left or right side of the  pointer button to adjust a slider bar.
  - To select from two or more settings, use the  pointer button to highlight the desired setting, then press Enter.
5. After changing the settings, press the ESC button to save your changes and return to the previous menu (or press it repeatedly to exit the menu system).



You can also press the Menu button to exit.

## Restoring the Default Settings

You can use the menu system's Reset options to restore the factory-default settings for:

- all the settings listed in a specific menu
- all the settings in all menus

To restore the settings in a specific menu, enter the menu whose settings you want to change, select Reset, and confirm as needed. (The example below shows how to reset the Video menu.)

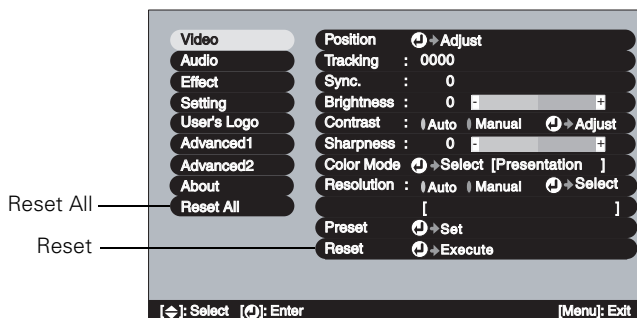

### note

Reset All *does not* reset the Computer Input, BNC Input, User's Logo, Language, Projector ID, Network, and Lamp settings.

To restore all the projector settings to their factory-default values, select Reset All.

## Adjusting the Image Quality

You can use the Video menu to adjust the brightness, sharpness, color, tint, and contrast. If you're projecting from a computer (but not through the DVI port), there are additional adjustments you can make (see page 127).

### Adjusting Images from Video Sources

1. Press the Menu button on the remote control, then select the Video menu.

You see the Video menu screen. (The actual settings may vary, depending on the selected input source. The Video menu below is for a composite video or S-video source.)

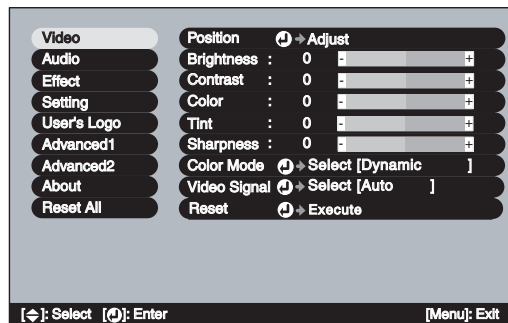

#### note

The Brightness setting changes the opacity of the projector's LCD panels. You can also change the lamp's brightness. Select

Brightness Control in the Advanced 2 menu, then choose High or Low (the default setting is High).

2. Use the  pointer button to highlight the desired option, then adjust it as needed:
  - **Position**  
If the image is slightly cut off on one or more sides, it may not be centered exactly. Use this setting to center it (not available for RGB video images).
  - **Brightness**  
Lightens or darkens the overall image.
  - **Contrast**  
Adjusts the difference between light and dark areas.

- **Color**  
Adjusts the color intensity, from black-and-white to full color (not available for RGB video images).
- **Tint**  
Adjusts the tint of the image (not available for RGB video images).
- **Sharpness**  
Adjusts the sharpness of the image.

## Adjusting Computer Images

You can also adjust brightness, contrast, and sharpness when you're projecting a computer image. In addition, if you're projecting an analog RGB image transmitted through the Computer or BNC port(s), you can make several other settings.

1. Press the **Menu** button on the remote control, then select the **Video** menu.

You see a screen similar to the one below. (The settings will be different if you're projecting a digital RGB image transmitted through the DVI port.)

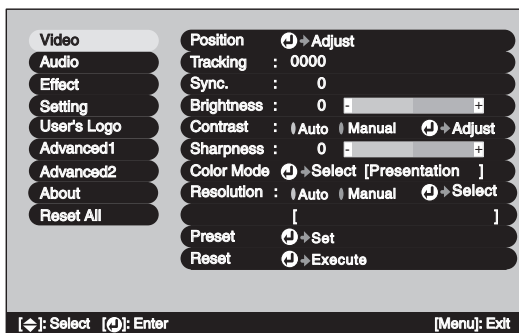

- **Position**  
If the image is slightly cut off on one or more sides, it may not be centered exactly. Use this setting to center it.
- **Tracking**  
Adjust this value to eliminate vertical stripes in the image.

### note

You can also use the remote control's **Auto** button to automatically reset the projector's tracking, sync, resolution, and position settings. See page 28 for details.

### tip

Before adjusting tracking or sync, fill the screen with an image containing fine detail. For example, in Windows you can select a pattern to appear as your desktop background. If this option isn't available, try projecting black text on a white background.

- **Sync**  
Adjust this value if the image appears blurry or flickers.
- **Brightness**  
Lightens or darkens the overall image.
- **Contrast**  
Adjusts the difference between light and dark areas. Select **Auto** to let the projector adjust the contrast automatically, or select **Manual** to adjust the setting yourself. (Press **Enter** after you make the selection.)
- **Sharpness**  
Adjusts the sharpness of the image.
- **Resolution**  
If your image is distorted (compressed, stretched, partially cut off, or doesn't completely fill the display area), the projector's resolution setting may not match that of your computer. Select **Auto** to let the projector adjust the resolution automatically, or **Manual** to adjust the setting yourself. (Press **Enter** after you make the selection.)
- **Preset**  
Once you've fine-tuned the settings in the Video menu for the computer you're using, you can save them as a group using one of the ten **Preset** settings. The next time you use the same computer, simply press the **Preset** button on the remote control to recall your saved settings. (Press the **Preset** button repeatedly to select the number corresponding to the setting you want to use.)

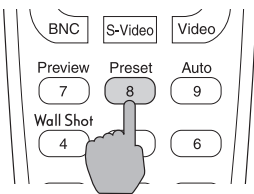



# Adjusting the Image Size, Shape, and Position

Whether you're projecting from a computer or video player, you can use these settings to adjust the size, shape, and position of the image.

## ■ Resize button

Adjusts how an image fits into the display area.

For computer images, resizing is normally unnecessary, since the projector automatically resizes the image to make the best use of the display area. If you press the **Resize** button on the remote control, the projector displays the image at the output resolution of the computer (which makes the image larger or smaller, depending on its resolution). If the resolution of the image is the same as the projector's (1024 × 768), pressing **Resize** has no effect.

For video images, pressing **resize** switches the aspect ratio between 4:3 and 16:9. This lets you play certain digital video images or movies recorded on certain DVDs in 16:9 widescreen format.

## ■ Keystone (in the Setting menu)

Squares up the shape of the image after the projector has been tilted upward or angled to one side (see page 26). If you notice lines or edges looking jagged after adjusting the shape, decrease the Sharpness setting (see page 128).

## ■ Position (in the Video menu)

If the image is slightly cut off on one or more sides, it may not be centered exactly. You can use this setting to center it (not available for digital RGB or RGB video images).

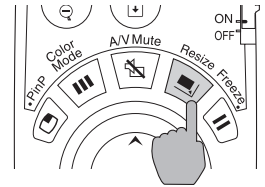

## **note**

*If your computer image is stretched, compressed, or doesn't fit correctly on the screen, you should try adjusting the Resolution setting first (see page 128).*

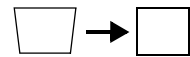

# Adjusting the Color

The projector provides several ways for you to adjust the color:

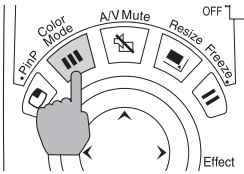

- **Color Mode button** (also in the Video menu)  
Lets you quickly adjust the color and brightness for various environments. Use either the remote control or the **Color Mode** setting in the Video menu; you can save a different setting for each computer and/or video source. Select from these settings:

**sRGB:** To use the sRGB standard for computer displays (the default when projecting from a computer with analog video)

**Dynamic:** For presentations in bright rooms

**Presentation:** For presentations in dark rooms

**Theatre:** For optimizing movie images with natural color (the default for video display)

**Living Room:** For optimizing video games

- **Color** (in the Video menu)  
Adjusts the color intensity, from black-and-white to full color (not available for adjusting computer images).
- **Tint** (in the Video menu)  
Adjusts the balance of magenta to green (not available for adjusting computer images or RGB video images).
- **Color Adjustment** (in the Advanced 1 menu)  
Adjusts the color temperature. Select **Color Temp.** to set a temperature between 5000 and 10000 °K. Or select **RGB** to adjust individual red, green, and blue values, as shown. (Not available if sRGB is selected as the Color Mode setting.)

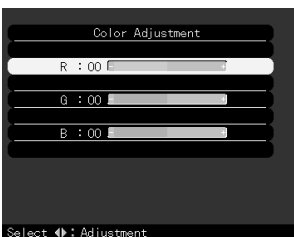



# Adjusting the Sound

You can use the Audio menu to adjust the sound volume or treble/bass balance.

1. Press the **Menu** button on the remote control, then enter the **Audio** menu.

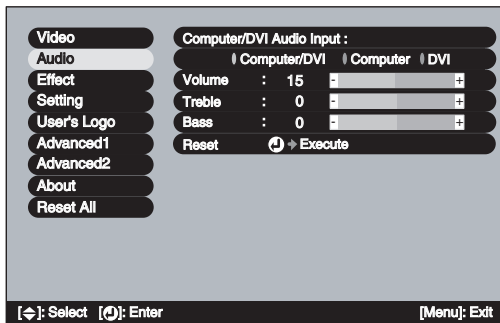
You see the Audio menu screen:



2. Use the  pointer button to highlight the desired option, then adjust it as needed:
  - **Volume**  
Adjusts the volume
  - **Treble**  
Adjusts the intensity of the treble range
  - **Bass**  
Adjusts the intensity of the bass range

## **note**

*You can also adjust the volume using the remote control.*

## Creating Your Own Startup Screen

You can transfer any image from your computer or video source to the projector, and then use it as your startup screen. You can also use it as the screen to be displayed when the projector is not receiving a signal or when you press the **A/V Mute** button. The image can be a company logo, slogan, photograph, or any other image you want to use.

### Capturing the Image

Start by displaying the image you want to use. It can be an image from either a computer or video source such as a DVD player or digital camera. Then follow these steps to capture the image and transfer it to the projector:

1. Press the **Menu** button on the remote control, highlight the **User's Logo** menu, and press **Enter**.

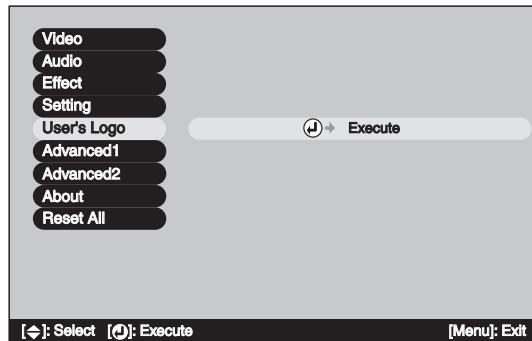

2. When you see a message asking whether you accept the present image as the user's logo, select **Yes** and press **Enter**.
3. A selection box displays over the image. Use the  pointer button to select the area of the image you want to use. Then press **Enter**.

4. When you see the message **Select this Image?**, highlight **Yes** and press **Enter**.
5. Use the arrow buttons to select a zoom rate (display size), and then press **Enter**.

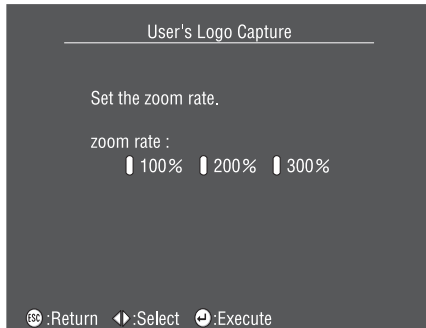

6. When the message **Save image as user's logo?** appears, select **Yes** and press **Enter**.

Saving the logo may take a few moments. Do not use your projector or video source (computer, DVD player, etc.) while the logo is being saved.

7. When you see the message **Completed**, press **ESC** to return to the menu screen.

## ***Choosing When to Display the Image***

After your image is saved, you can set it up as the startup screen, or the screen you see when there's no signal or when you press the **A/V Mute** button (see page 38).

1. Press the **Menu** button to display the menu screen (if not already displayed).
2. To display your image as the startup screen, highlight the **Advanced1** menu, then press **Enter**. Select **Startup Screen**, highlight **ON**, then press **Enter**.

To display your image on the No-Signal or A/V Mute screen, continue with the following steps.

3. Highlight the **Setting** menu, then press **Enter**.
4. Select the screen(s) on which you want your image to appear:
  - Highlight **No-Signal Msg.** if you want to display your image (instead of a blank screen) when there is no video signal incoming from the currently selected source.
  - Highlight **A/V Mute** if you want your image to appear when you press the **A/V Mute** button.
5. Select **Logo**, then press **Enter**. This sets your image as the screen to be displayed. (Or select **Blue** if you prefer to display a blue screen instead.)
6. When you're finished, press **ESC** to exit.

# Controlling Multiple Projectors

If you're using more than one projector for your presentation, you can use the projector's ID system to switch between them using a single remote control. To do this, you need to set a different ID for each projector. During the presentation, it's easy to change the remote control's ID to match that of the projector you want to use. When you want to switch, simply change the remote control's ID to match that of your second projector.

## Setting the Projector ID

The projector's default ID is 1. Follow these steps to change it:

1. Press the **Menu** button on the remote control.  
You see the projector's menu screen.
2. Select the **Advanced2** menu and press **Enter**. Then highlight **Projector ID** and press **Enter**.

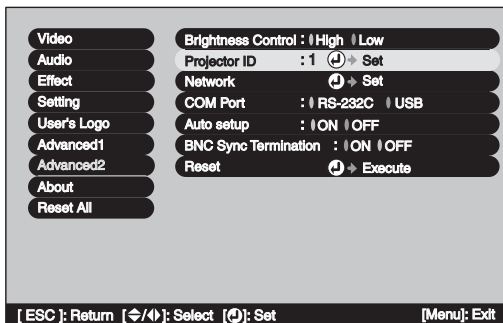

3. Press the right or left side of the  pointer button to increase or decrease the ID value.
4. Press **Enter** to set the value.
5. When done, press **ESC** to exit the menu system.

### note

*By default, the remote control's ID is set to zero, which allows it to control any projector. If you want to control multiple projectors simultaneously, and you don't want to switch between them (each projector would need its own screen), you can leave the remote control's ID set to zero. In this situation, you would not need to change the projector's ID.*

## Changing the Remote Control ID

To change the remote control's ID to match that of a projector, follow these steps:

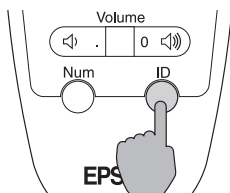

1. Press the ID button on the remote control. You see it light.
2. Press one of the numbered buttons on the remote control to select the ID of the projector you want to operate.

The ID button's light shuts off and the new ID is registered.

3. Repeat steps 1 and 2 each time you want to switch projectors.

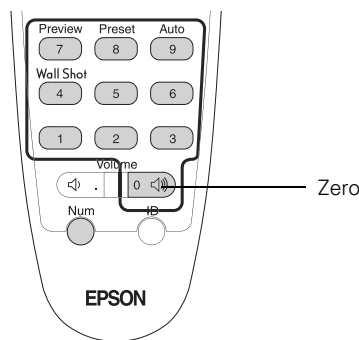

To check the remote control's current ID, do the following:

1. Press the ID button twice in succession. After a moment, the button flashes.
2. Count the number of flashes; this number corresponds to the remote control's ID. (If it doesn't flash, the ID is set to zero.)



## *Customizing Projector Features*

You can use the menu system to change the video signal input at certain ports, turn sleep mode on or off, adjust the network settings, change the language, and customize several other features.

### ***Image Setup Options***

Use these settings to change how the projector processes incoming video signals. Several of these settings should normally be left at the factory default setting (except for the **Computer** and **BNC Input** settings).

- **Computer Input** (in the Setting menu)  
Select the setting for the type of equipment you've connected to the **Computer** port:
  - Analog-RGB: For a computer connection
  - RGB-Video: For a video player that outputs an RGB video signal
- **BNC Input** (in the Setting menu)  
Select the setting for the type of equipment you've connected to the **BNC** ports:
  - Analog-RGB: For a computer connection
  - RGB-Video: For a video player that outputs an RGB video signal
  - YCbCr: For a video player that outputs an NTSC component video signal
  - YPbPr: For a video player that outputs an HDTV component video signal
- **Video Signal** (in the Video menu)  
Leave this setting at **Auto** unless you are using a 60-hertz PAL system (select **PAL60**). You can change this setting only if you're displaying an image through the **Video** or **S-Video** port.

- **Progressive** (in the Advanced 1 menu)  
This setting should normally be left at its default setting (**Video** or **Film/Auto**). Converts interlaced signals to progressive signals. When set to **OFF**, interlaced signals are processed without conversion (available for video signals only).
- **BNC Sync Termination** (in the Advanced 2 menu)  
This setting should normally be left **Off** (for TTL input). If an analog (75-ohm) terminator is required, as for a switcher, change the setting to **ON**.

---

### **note**

When Standby Mode is set to **Network ON**, the exhaust fan continues to operate after the projector has cooled down. This is normal.

---



---

### **note**

Press the **Num** button on the remote control to use the number keypad.

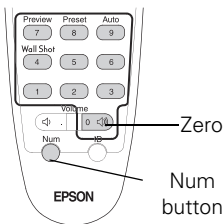

## **Remote Monitoring Setup Options**

These options let you set up the projector so it can be monitored and controlled from a remote computer (see Chapter 7).

- **Standby Mode** (in the Advanced 1 menu)  
Select **Network ON** to enable the projector to be monitored over a network when it's in standby mode.
- **Network** (in the Advanced 2 menu)  
Used for managing the projector over a wired network (see Chapter 7). If the network assigns addresses automatically, turn on **DHCP**. Otherwise, turn off **DHCP** and enter the projector's **IP Address**, **Subnet Mask**, and **Gateway Address**, if applicable.

If you want to monitor the projector using a network management utility, select **SNMP** and enter at least one trap IP address.

- **COM Port** (in the Advanced 2 menu)  
Used for communicating with a computer running the EMP Link21L utility software. Select **RS-232C** or **USB**, depending on the port that's being used for communication with the computer. Turn off the projector and then turn it back on for the new setting to take effect.

## ***Miscellaneous Setup Options***

- **No-Signal Msg.** (in the Setting menu)  
Selects a screen color or image to display when the projector is not receiving a signal. The logo setting displays an image that you previously transferred to the projector (see page 132).
- **Sleep mode** (in the Setting menu)  
When sleep mode is on, the projector turns off the lamp if it has not received any input signals for 30 minutes. Turn sleep mode off if you want the lamp to remain on all the time (this is the default setting).
- **Message** (in the Setting menu)  
Selects whether the image source or the color mode is displayed on the screen.
- **Rear Proj.** (in the Advanced 1 menu)  
Turn on to project from behind onto a transparent screen.
- **Ceiling** (in the Advanced 1 menu)  
Turn on when the projector is mounted upside-down from the ceiling.
- **Language** (in the Advanced 1 menu)  
Select from nine languages to be used for the projector menus.



# 7 *Managing Projectors*

---

## **note**

*A plug-in will be available to allow you to manage your projectors in HP OpenView. Check with your dealer or EPSON for availability (see page 191).*

*If you're using a network management utility running SNMP, you can configure your network to send trap alerts even without a plug-in (see page 142). This feature is intended for use by network administrators only.*

---

The EasyManagement software for your projector lets you monitor and control your projectors from a remote computer in several ways:

- Use EMP Monitor to see your projectors' status, switch image sources, and control basic settings.
- Use the mail notification function to receive e-mail alerts about possible problems.
- Use a network management utility running SNMP, such as HP OpenView, to manage your facility's equipment from a pre-existing system.

You can also use NS Connection to register up to 16 projectors as a group. This allows you to provide quick and easy access to these projectors to other computers.

To use the EasyManagement software to manage your projectors, first install EMP Monitor as described in Appendix A. If you plan to create projector groups, also install EMP NS Connection. Then connect and configure each projector you want to monitor. You can connect the projector wirelessly in Access Point mode, as described on page 77, or over a wired network, as described on page 142.

This chapter covers the following information:

- Connecting the projector to and configuring it for a wired network
- Monitoring and controlling your projector with EMP Monitor
- Using e-mail alerts to warn you of problems
- Understanding notification messages
- Using a browser to monitor the projector
- Using projector groups

## Connecting and Configuring the Projector on a Wired Network

### note

For information about supported PCMCIA LAN cards, contact EPSON as described on page 191.

### note

If you're a network administrator, you can use the SNMP option to enter a trap IP address. This lets you receive trap alerts for the projectors you're monitoring. If you have HP OpenView, a plug-in will be available to allow you to manage your projectors in HP OpenView. Check with EPSON for availability (see page 191).

You can also configure your wireless network to receive trap alerts. Your projector must be connected in Access Point mode. Select the Advanced button next to the Access Point mode box, then select SNMP and enter the IP addresses of the computers to be notified of an SNMP trap.

Before using the EasyManagement software to manage your projector(s), you have to connect each projector you want to monitor to your network and configure it with an appropriate IP address. You can connect and configure the projector wirelessly, as described in Chapter 4, or you can connect using a PCMCIA LAN card.

Follow these steps to use a PCMCIA LAN card to connect and configure the projector for your network.

1. Insert the PCMCIA LAN card into the card slot on the back of the projector. Then connect the projector to your network using a commercially available 100baseTX or 10baseT network cable.
2. Turn on the projector (see page 18).
3. Press the Menu button on the remote control and select Network from the Advanced2 menu.

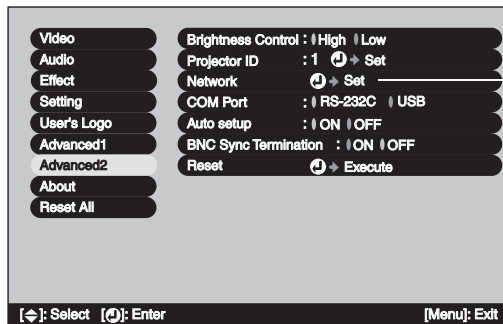

4. If your network assigns addresses automatically, turn on DHCP. If your network does not assign addresses automatically, turn off DHCP and enter the projector's IP Address, Subnet Mask, Gateway Address, and MAC Address, as needed.

- To enter numbers using the remote control, press the Num button until it lights, then use the number keypad shown below.

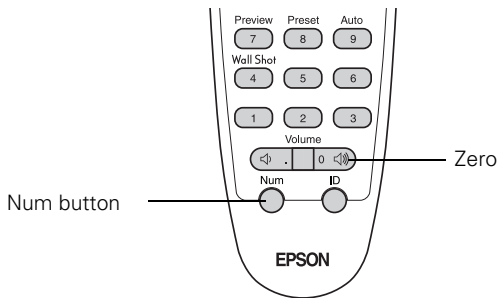

- To change the network addresses from the projector's control panel, press the right and left arrow buttons to select the part of the address you want to enter, then use the up and down arrow buttons to increase or decrease the numeric value.

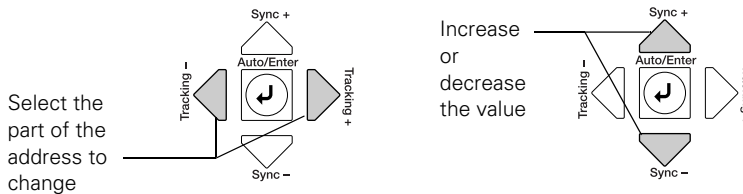

When you finish changing an address in the network menu, press the **Enter** button (on the remote control) or the **Auto/Enter** button (on the projector). This stores the value.

5. When done making all necessary changes, press **ESC** to exit the menu system.

## Using EMP Monitor

### **note**

*If you want to monitor projectors while they are in standby mode, select **Standby Mode** in the **Advanced 1** menu, then select **Network ON**. See page 138.*

EMP Monitor lets you use a remote computer to manage your projectors, whether connected wirelessly or over a wired network. It lets you easily turn the projectors on or off (together or individually), switch image sources, and check their status.

Before using EMP Monitor, make sure you've installed the software as described in Appendix A. The computer you're using to monitor the projector should already be connected to your network.

### **Opening and Closing EMP Monitor**

To start EMP Monitor, click **Start > Programs** or **All Programs > EPSON Projector > EMP Monitor**.

If you've added the program to the Startup programs folder (see page 151), then it may already be open. If so, click the icon in the system tray on the lower-right corner of your screen to display the EMP Monitor window:



Click here to start EMP Monitor

To close EMP Monitor, right-click the program icon shown above, then select **Exit**.



## Registering a Projector

Before you can monitor a projector, you have to register it. Follow these steps:

1. Click **Start > Programs or All Programs > EPSON Projector > EMP Monitor**. You see this screen:

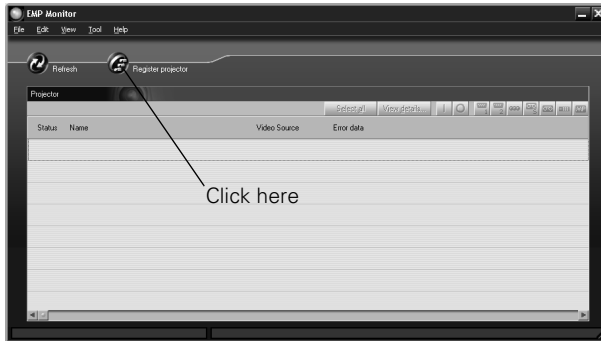

2. Click **Register projector** as shown.

You see this screen:



3. Click **Auto detect** to locate projectors currently operating on the network. Or click **Manual registration** and enter the projector's name and network address.

### **note**

*If Auto detect fails to find the projector, your projector may not be connected or configured correctly for the network. See page 142 to configure your projector for a wired network, or Chapter 4 to configure the projector for a wireless network.*

Any projectors found on the network are listed as shown below:

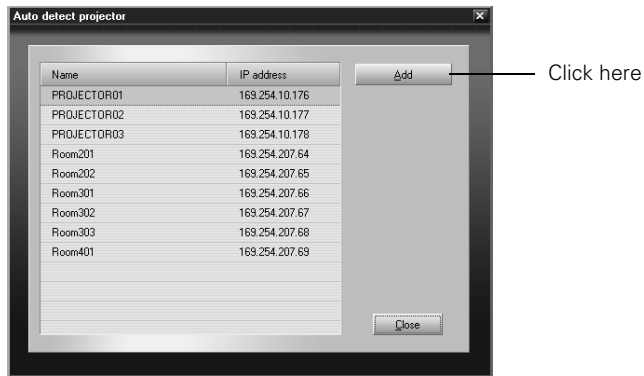

4. Select each projector you want to add by clicking its name, then clicking the **Add** button. When you're done adding projectors, click **Close**.

You see this screen with a list of all registered projectors.

**note**

*To delete a projector from the list, highlight the projector name, and click **Delete**.*

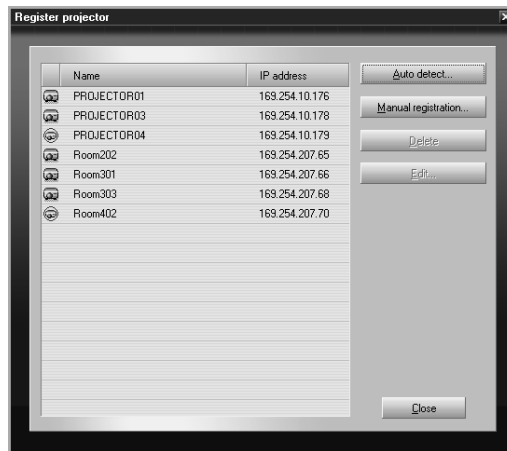

5. Click **Close**.

You see the status of each of your registered projectors on the main EMP Monitor screen:



## Monitoring Your Projectors

The EMP Monitor screen lets you monitor your projectors using the Status, Video Source, and Error icons shown below. These let you see which projectors are currently being used, from which source (or port) they are projecting an image, and if a problem occurs.

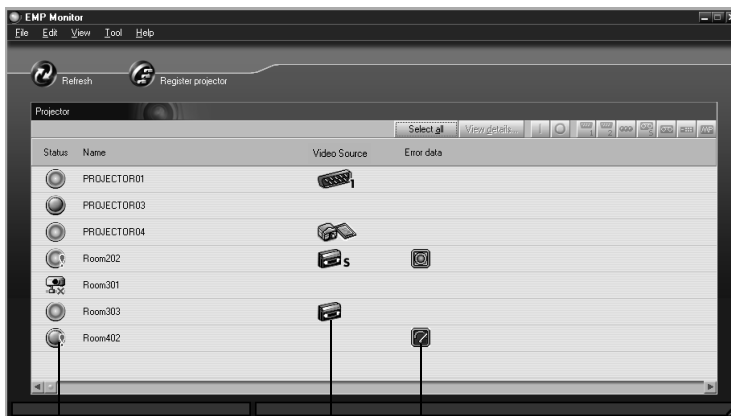

Status icon

Video Source icon

Error icon

For detailed status information, select the projector in question and click View details.





### **note**

To monitor a projector when it's in standby mode (plugged in but not turned on), you must select **Network ON** as the **Standby Mode** setting in the projector's menu system (see page 138).

Remember that when **Standby Mode** is set to **Network ON**, the exhaust fan continues to operate after the projector has cooled down. This is normal.







The following table explains the meaning of the status icons:

*Status icons*

 (green)	Projecting; no problems
 (dark)	Turned off; no problems
 (green)	Projecting; problems detected
 (dark)	Turned off; problems detected
	Network error (for example, not connected to network, or power cable disconnected). You may also see this error if <b>Network OFF</b> is selected in Standby Mode (see page 138).







The following table explains the meaning of the video source icons:

*Video source icons*

	Computer
	BNC
	S-video
	Video
	DVI
	EasyMP

The following table explains the meaning of the error icons (see Chapter 9 for recommended solutions to problems):

*Error icons*

	Lamp replacement notification (the lamp is nearing the end of its life; see page 170)
	High-speed cooling in progress (the projector is getting too hot but continues to operate)
	Overheating (projection turned off automatically)
	Lamp out or lamp cover open
	Fan error
	Sensor error
	Internal problem

## Controlling Your Projectors

The control buttons in the upper-right let you select video signals and turn projectors on or off. (Hold the pointer over a button to see a description of its function.) Select the projector you want to operate (with the mouse pointer) before clicking one of the buttons.

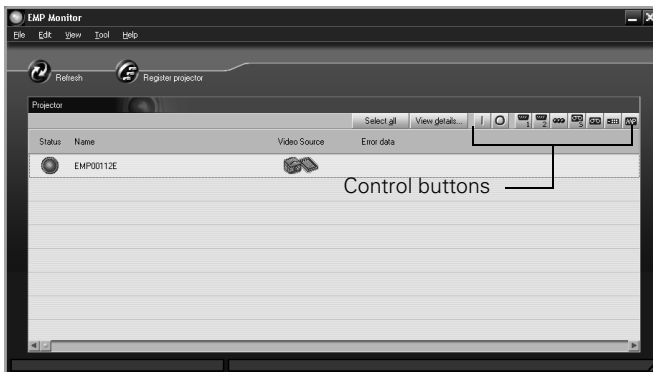









**note**

*To turn on a projector when it's in standby mode (plugged in but not projecting), you must have selected **Network ON** as the **Standby Mode** setting in the projector's menu system (see page 138).*

*Remember that when **Standby Mode** is set to **Network ON**, the exhaust fan continues to operate after the projector has cooled down. This is normal.*

The following table explains the functions of the control buttons:

*Control buttons*

	Turns the projector on
	Turns the projector off
	Changes the video signal to the <b>Computer</b> port
	Changes the video signal to the <b>BNC</b> ports
	Changes the video signal to the <b>S-Video</b> port
	Changes the video signal to the <b>Video</b> port
	Changes the video signal to the <b>DVI</b> port
	Switches the display to <b>EasyMP</b>

## Configuring the Monitoring Interval

If you need to have the most current status information about your projectors, click the **Refresh** button in the EMP Monitor screen.

You can also select how often EMP Monitor checks the projector status:

1. From the Tool menu, select **Configuration**.

You see this screen.

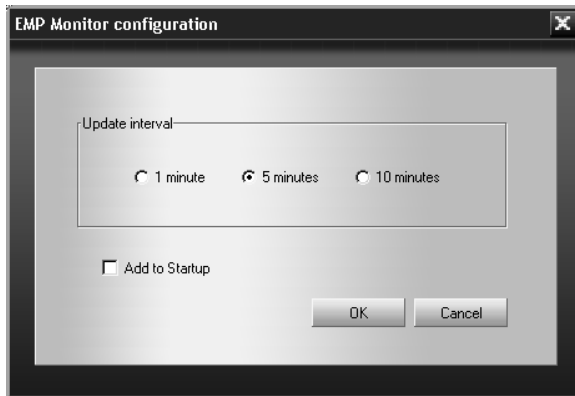

2. Select the desired update interval and click **OK**.

---

### **note**

*If you want EMP Monitor to run whenever you start your computer, click **Add to Startup**.*

---

## Using E-mail Alerts

You can set up e-mail alerts to warn you of problems with the projector on either a wireless network or a wired LAN connection.

### note

*The projector must be plugged in (projecting or in standby mode) for you to be able to connect to it. To access a projector in standby mode, you must select **Network ON** as the Standby Mode setting in the projector's menu system (see page 138.)*

*Remember that the exhaust fan continues to operate after the projector enters standby mode.*

1. Do one of the following:
  - Insert the EPSON 802.11b wireless card and set up your projector to work in Access Point mode, as described on page 77.
  - Insert your LAN card and configure your projector for a wired network, as described on page 142.
2. Turn on your projector and remote control. Press the **EasyMP** button on the remote control to switch to EasyMP. You see the following screen:

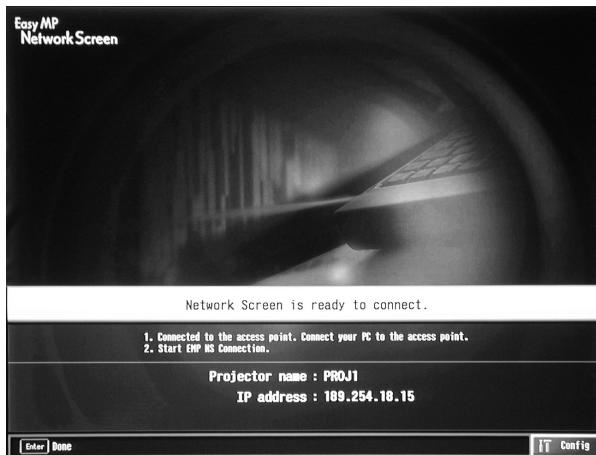

3. Select **Config** in the lower right corner of the screen and press **Enter** on the remote control.

If you're connecting over a wired LAN network, go to step 5.

If you're connecting over a wireless network, continue with the next step.



- Wireless network only: On the Network Screen, select the **Advanced** button next to the Access point mode box. Press **Enter** on the remote control.

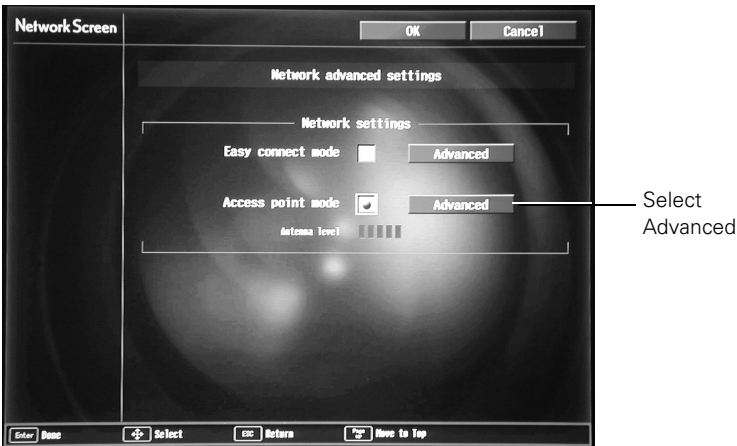

- When you see the screen below, select **Mail** and press **Enter**.

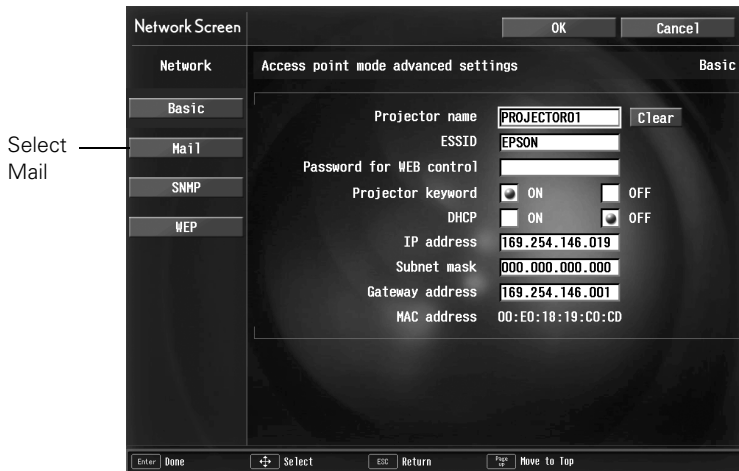

**note**

*The ESSID option is not displayed if you are connecting over a wired LAN network.*

You see the following screen:



### note

To enter numbers with the remote control, press the Num button. When the button lights up, the numeric keypad is active. Press the Num button again to exit numeric keypad mode.

### note

Use the  button on the remote control to enter letters. Press the top of the button to scroll through capital letters, and the bottom of the button to scroll through lowercase letters. You will also see punctuation marks, such as a period (.) and symbols, such as @. When you see the letter or symbol you want, press Enter. Then press the right side of the button to move to the next position. To correct a mistake, press the left side of the button to return to the previous

- For Mail Notification Settings, select ON and press Enter on the remote control.
- Highlight the IP address of SMTP server box and press Enter. The outline of the box turns green to indicate you are in input mode. You can enter numbers between 0 and 255. However, you cannot use the following IP addresses: 255.255.255.255, 224.0.0.0, or 127.x.x.x (where x is a number between 0 and 255).
- Highlight the Port Number box and press Enter. Then enter the SMTP server port number. The default value is 25, but you can enter numbers between 1 and 65535.
- Highlight the box for Destination address 1 and press Enter. Enter the e-mail address for the first computer that you want to receive e-mail alerts. You can enter a maximum of 53 single-byte alphanumeric characters.
- If you want to send e-mail alerts to one or two other computers, enter addresses for those computers in Destination address 2 and Destination address 3.
- Select the conditions under which an e-mail alert will be sent.

12. When done making your settings, highlight the OK button at the top of the screen (you can either use the  button on the remote control or press ESC to highlight it), then press Enter. Highlight the OK button again and press Enter to return to the main EasyMP Network Screen.

For help understanding e-mail alerts, see page 155.

## *Understanding the Notification Messages*

If a projector experiences a problem, it sends an e-mail message to each of the addresses you provided using EMP NetworkManager. The message includes the heading “EPSON Projector” in the subject line.

The body of the message contains:

- the name of the projector
- the projector’s IP address
- a description of the problem

The problem descriptions are similar to the errors reported by EMP Monitor listed on page 149.

If a plus (+) sign appears before the description, it indicates that a problem has occurred. A minus (–) sign appears when the problem goes away or is resolved.

---

### **note**

*If a projector develops a critical problem, it may not be possible for it to report the error.*

---

## Using a Browser to Monitor Projectors

### note

You can't use your browser to monitor projectors if it is set up to connect via a proxy server.

If you are using Microsoft Internet Explorer, use version 5.0 or later.

The projector must be plugged in (projecting or in standby mode) for you to be able to monitor it. To access a projector in standby mode, you must select **Network ON** as the Standby Mode setting in the projector's menu system (see page 138.)

Remember that the exhaust fan continues to operate after the projector enters standby mode.

If your projectors are connected to a network (802.11b wireless or wired LAN), you can use a standard web browser to monitor and control each one.

1. Do one of the following:
  - Make sure the PCMCIA LAN card is inserted in the projector's card slot and the projector is set up for your wired LAN network, as described on page 142. (Standby Mode in the Advanced 1 menu should be set to **Network ON** to monitor projectors in standby mode.)
  - Make sure the EPSON 802.11b wireless card is inserted in the projector's card slot and the projector is configured for Access Point mode, as described on page 77.
2. Open the web browser and enter the IP address of the projector you want to monitor in the browser window.

If you're not sure what address the projector is using, turn it on and switch it to EasyMP. You see a screen like this, which shows you the IP address:

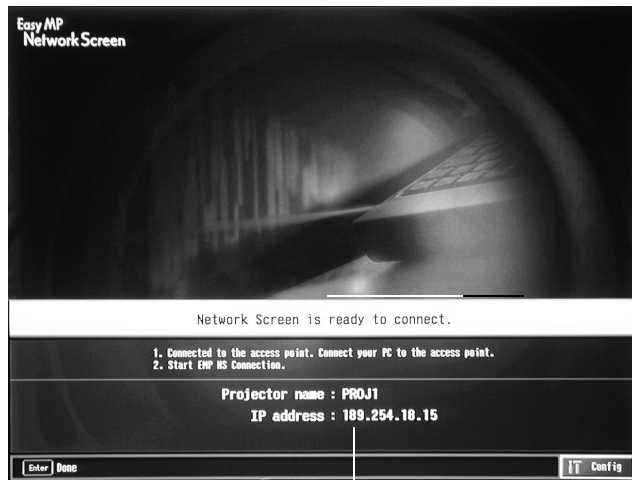

Projector  
IP address

3. If you're connected over a wired network, the projector's web screen opens in the browser window, as shown below.

If you're connected over an 802.11b wireless network, start NS Connection and connect to the projector you want to monitor. Then click  on the control bar that appears on the screen. The projector's web screen opens in the browser window.

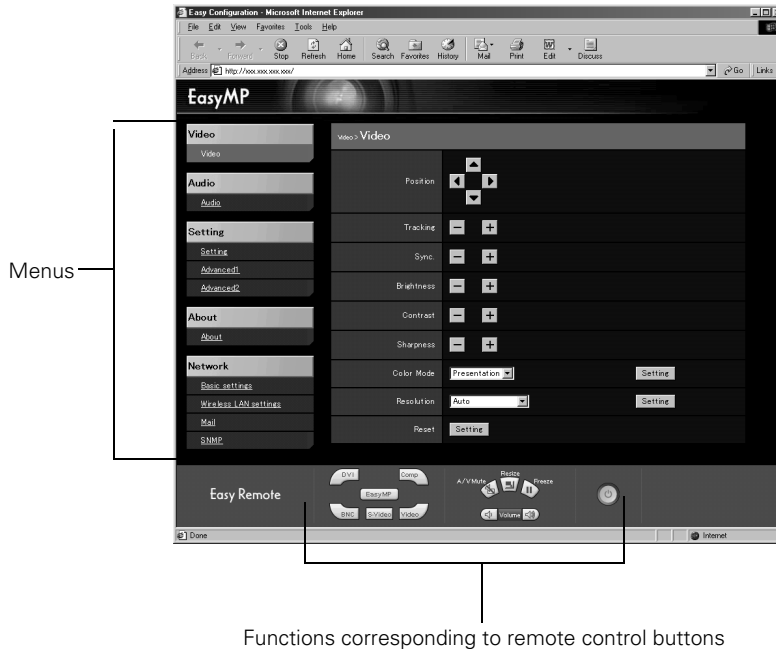

4. Select one of the menu options listed on the left, then change any settings as needed in the main part of the screen. These settings correspond to those found in the projector's menu system; for details, see Chapter 6.
5. Use the controls at the bottom of the screen just as you would the corresponding remote control buttons: choose a source, stop the action, control the volume, size the image, turn off the picture and sound, or turn the projector's power on or off.

For details about the remote control, see Chapter 2.

## Using Projector Groups

### tip

Use a static IP address when configuring a projector for the network if you plan to use it in a group. If you use DHCP, the projector's IP address will change every time you turn it off and on again, and you will have to recreate the projector group.

If any of the octets in a static IP address are less than 100, the first digit of the octet should be zero (0).

You can register projectors as a group if you want to provide quick and easy access to other computers. You can also export or import group information as a file to another computer. Projectors must be connected to the network in Access Point mode, and must be on the same network segment as the computer used to create the group, or the computers that import or export group information.

### Creating a Group

You can register up to 16 projectors as a group, and all projectors must be part of your wireless network.

1. Start NS Connection. Then click the **Extension** button on the EMP NS Connection screen. You see this screen:

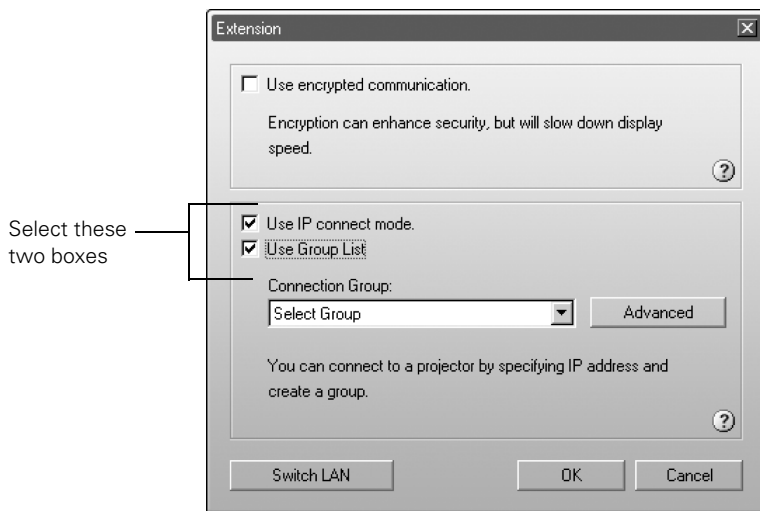

2. Select **Use IP connect mode** and **Use Group List**.

3. Click the **Advanced** button. You see this screen:

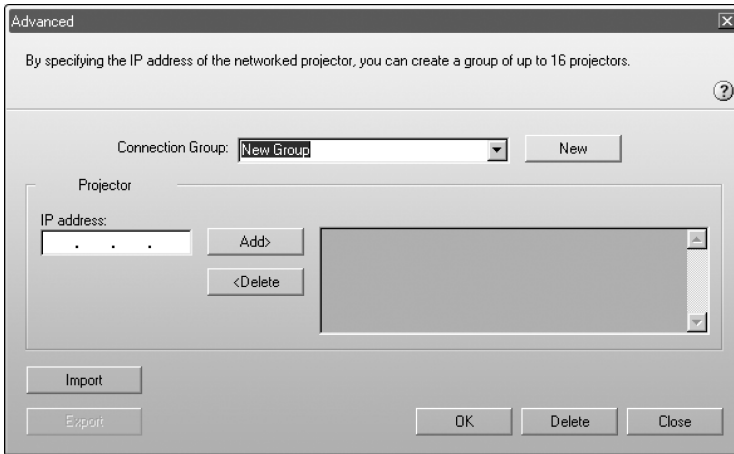

4. Enter a name for the group in the Connection Group box. Then enter the IP address of the projector you want to register in the IP address box:

---

**note**

*You cannot use the addresses 0.0.0.0 or 255.255.255.255.*

---

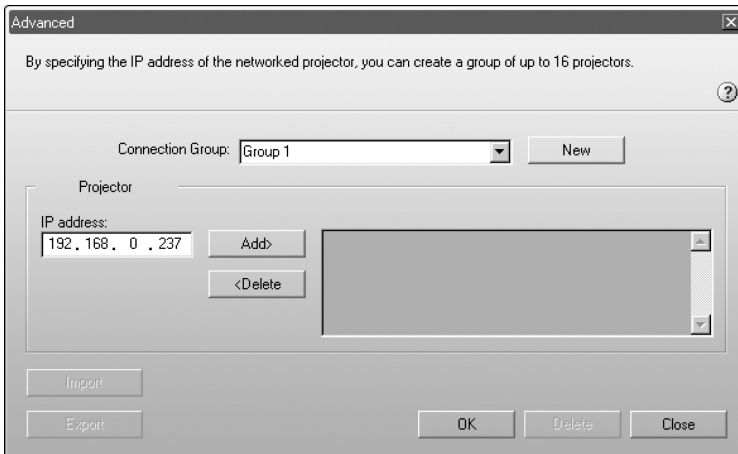

5. Click **Add**. The IP address appears in the list of registered printers, and the  searching icon appears beside it. If the projector is found, its name appears in the projector list.

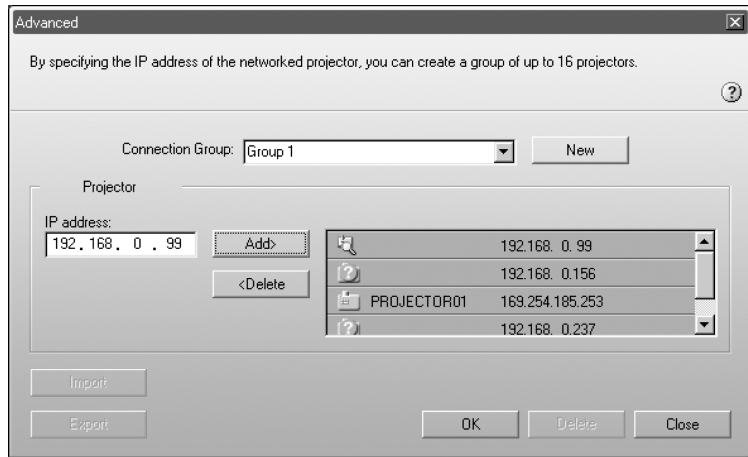

**note**

*To remove a projector from the group, select it from the projector list and click **Delete**.*

6. Repeat steps 4 and 5 for each projector you want to add to the group.
7. Click **OK** to save the projectors as a group. When you see a confirmation message, click **Yes**.
8. Click **Close** to close the Advanced screen.
9. Click **OK** to close the Extension screen, then close NS Connection.



## Connecting to a Projector in a Group

Follow these steps to connect to a projector in a group:

1. Start NS Connection. Then click the **Extension** button on the EMP NS Connection screen. You see this screen:

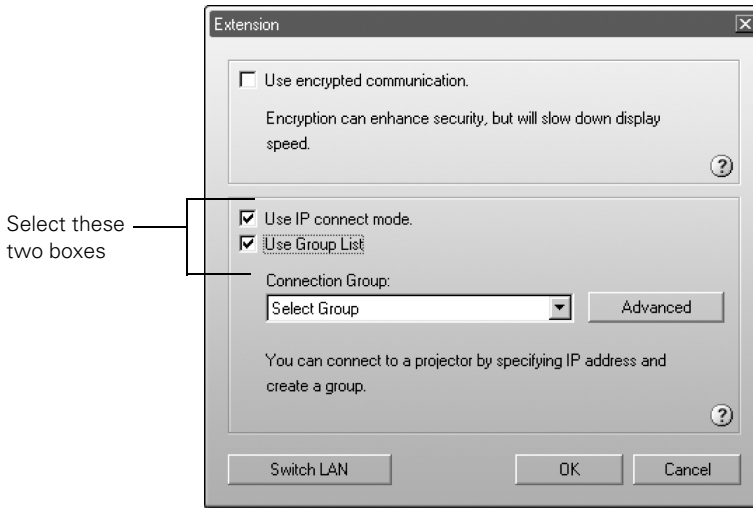

2. Select **Use IP connect mode** and **Use Group List**.
3. From the **Connection Group** list, choose the group you want to connect to and click **OK**.

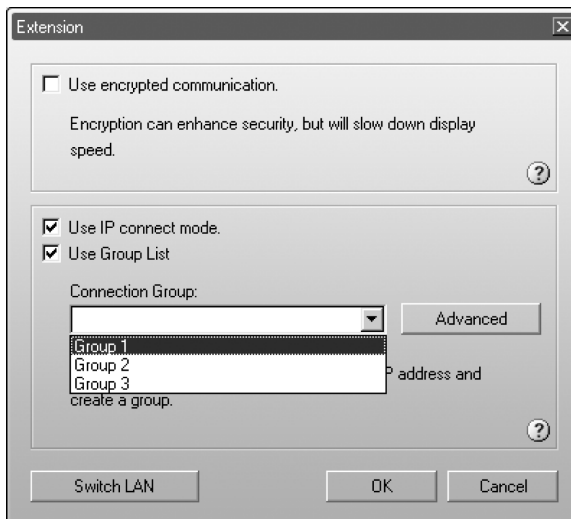

You see this screen:

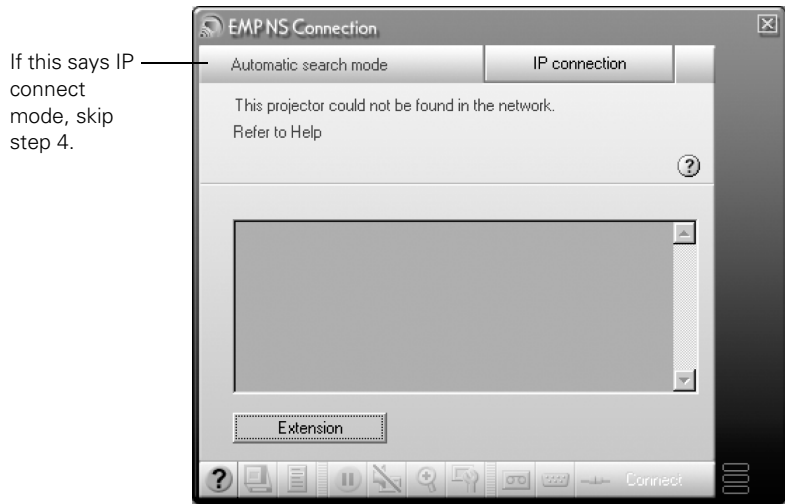

4. Click IP connection. (If the upper left button on the screen says IP connect mode rather than Automatic search mode, skip this step.)

You see this screen:

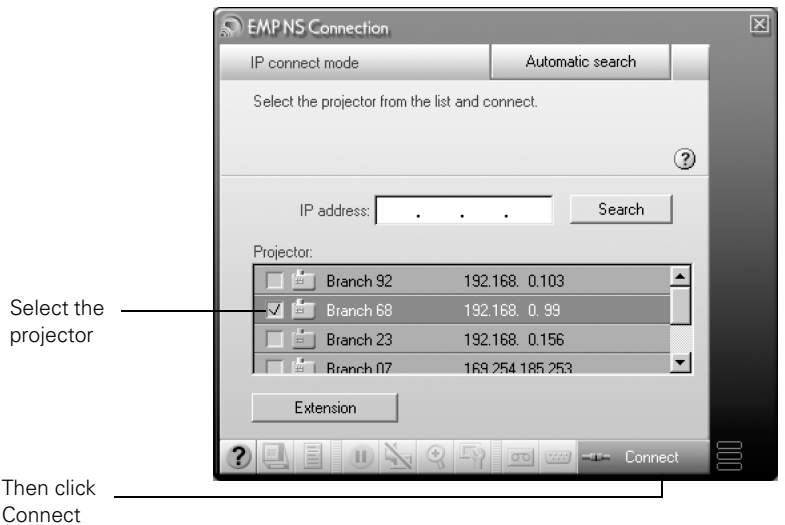

5. Select the projector you want to connect to and click Connect.

6. If you want, repeat step 5 to connect to additional projectors.

The computer's image appears on the projector screen.

## Exporting a Projector Group

You can export group information as a file to another computer on the wireless network. This is useful, for example, if you want to share group access with multiple users.

1. Start NS Connection. Then click the **Extension** button on the EMP NS Connection screen. You see this screen:

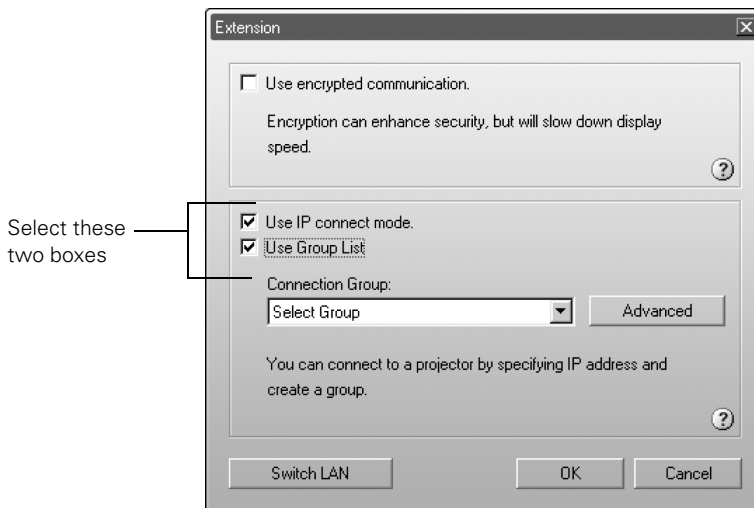

---

### note

*You must export all of the groups in the Connection Group list. You can't export individual groups.*

*Even if a projector is registered in a group, you don't have to use the group to connect to it. If your laptop is configured for your wireless network, you can connect to a projector as described on page 50.*

---

2. Select **Use IP connect mode** and **Use Group List**. Then click the **Advanced** button. You see this screen.

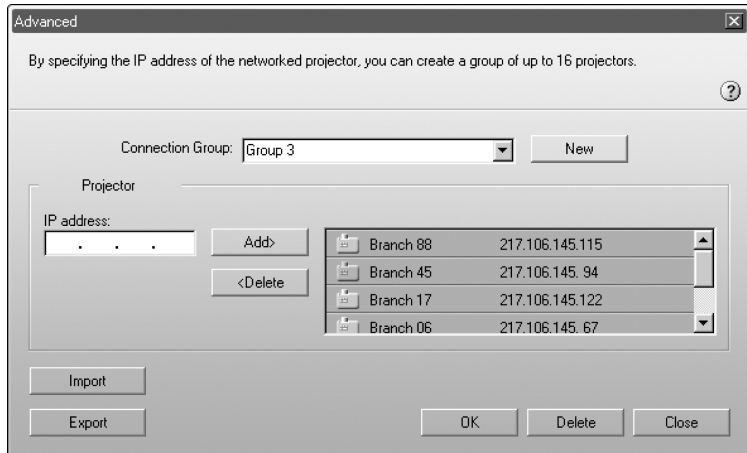

---

**note**

*If you haven't created any groups, the **Export** button will be grayed out. You must create at least one group before the **Export** button is active.*

---

3. Click **Export** to export a file for all groups in the Connection Group list.
4. Highlight the file name (**NSGroup.ini**), and then select **Save to**. Choose a location on the second computer and click **Save**.

To connect to the projector from the new computer, follow the steps beginning on page 161.

## Importing a Projector Group

You can also import group information as a file to another computer on the wireless network.

1. Start NS Connection. Then click the **Extension** button on the EMP NS Connection screen. You see this screen:

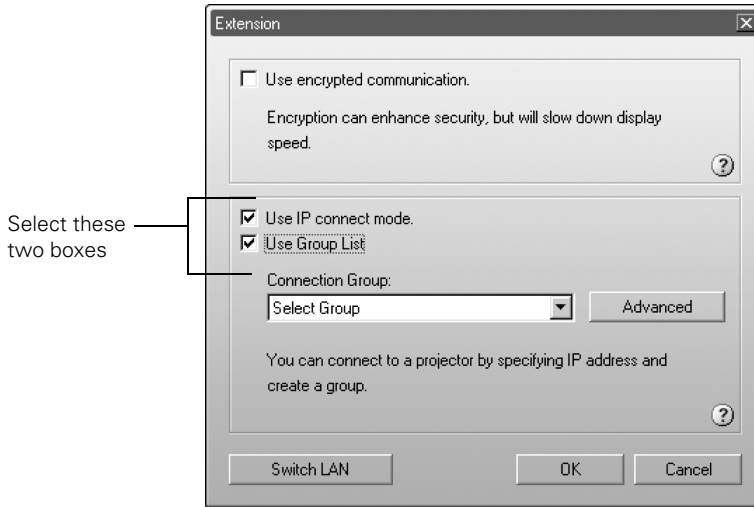

2. Select **Use IP connect mode** and **Use Group List**. Then click the **Advanced** button. You see this screen.

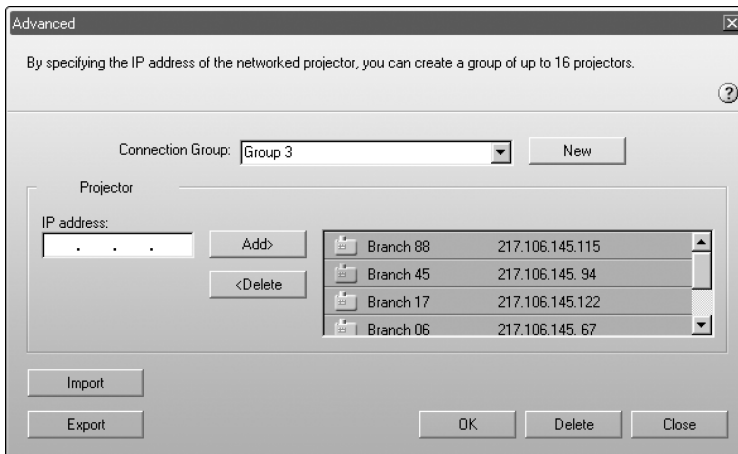

3. Click **Import**.

4. On the next screen, select the file you want to import and click **Open**.

The names of all of the groups in the file are added to the Connection Group list on the Advanced screen.

To connect to the projector from the new computer, follow the steps beginning on page 161.

# 8

## *Maintaining the Projector*

Your projector needs little maintenance. All you have to do on a regular basis is keep the lens clean. Any dirt or smears on the lens may show up on your projected image.

You also need to periodically clean the air filters at the side and base of the projector. A clogged air filter can block ventilation needed to cool the projector.

The only parts you should replace are the lamp and air filters (when you order a new lamp, replacement filters come with it). If any other part needs replacing, contact your dealer or a qualified servicer.

This chapter covers the following:

- Cleaning the lens
- Cleaning the projector case
- Cleaning the air filters and vents
- Replacing the lamp and air filters
- Transporting the projector

---

### **warning**

*Before you clean any part of the projector, turn it off and unplug the power cord.*

*Never open any cover on the projector, except the lamp cover. Dangerous electrical voltages in the projector can injure you severely. Do not try to service this product yourself, except as specifically explained in this User's Guide. Refer all other servicing to qualified service personnel.*

---

---

## *Cleaning the Lens*

Clean the lens whenever you notice dirt or dust on the surface.

- Use a canister of compressed air to remove dust.
- To remove dirt or smears on the lens, use lens-cleaning tissue. If necessary, moisten a soft cloth with lens cleaner and gently wipe the lens surface.

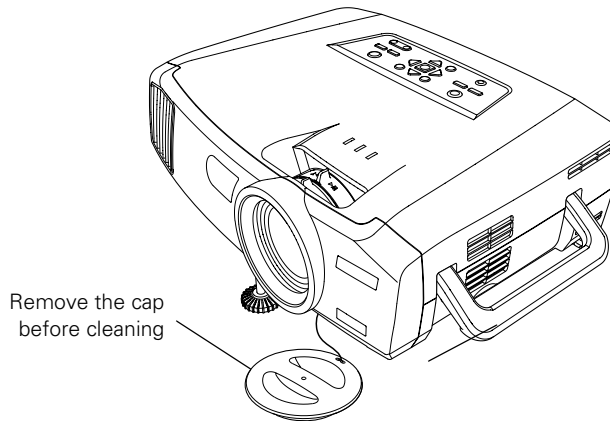

---

## *Cleaning the Projector Case*

Before you clean the case, first turn off the projector and unplug the power cord.

- To remove dirt or dust, wipe the case with a soft, dry, lint-free cloth.
- To remove stubborn dirt or stains, moisten a soft cloth with water and a neutral detergent. Then wipe the case.
- Do not use wax, alcohol, benzene, thinner, or other chemical detergents. These can damage the case.



## *Cleaning the Air Filters and Vents*

Clean the air filters and air intake vents after every 100 hours of use. If they are not cleaned periodically, they can become clogged with dust, preventing proper ventilation. This can cause overheating and damage the projector.

Follow these steps:

1. Turn off the projector and unplug the power cord.
2. To clean the intake vents, EPSON recommends using a small vacuum cleaner designed for computers and other office equipment. If you don't have one, gently clean the vents with a soft brush (such as an artist's paintbrush).

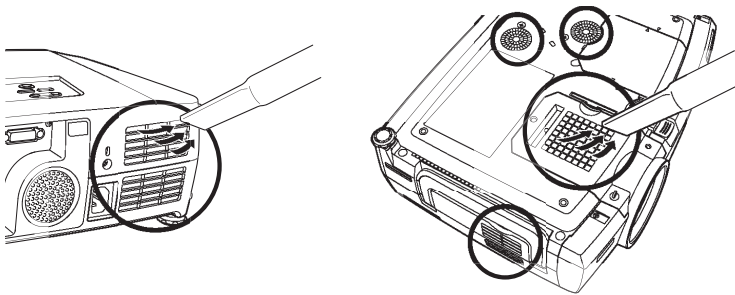

3. Gently turn the projector over and remove the filters from the side and bottom of the projector. Then use a small vacuum cleaner or soft brush to clean the filters. Slide the filters back into place when you're done.

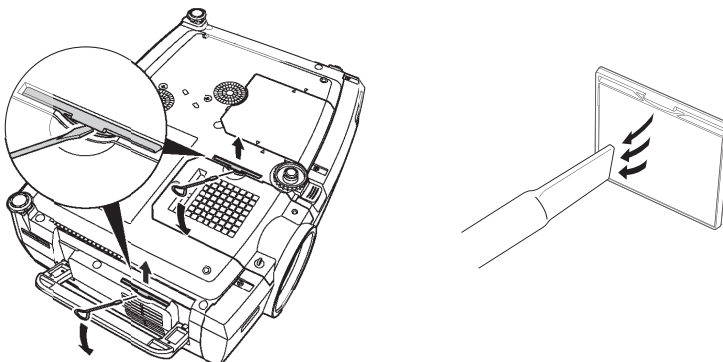



### **note**

To order replacement air filters without the lamp, request part number V13H134A01. See page 14 for ordering information.

4. If the dirt is difficult to remove or a filter is broken, replace the filters as described on the next page. Contact your dealer or call EPSON at (800) 873-7766 in the United States to obtain new ones. In Canada, please call (800) 463-7766 for dealer referral.

## *Replacing the Lamp and Air Filters*

The life span of the projection lamp is about 2000 hours if **Brightness Control** in the Advanced 2 menu is set to **High** (default), and 3000 hours if **Brightness Control** is set to **Low**. It is time to replace the lamp when:

- The projected image gets darker or starts to deteriorate.
- The message **LAMP REPLACE** appears on the screen when the lamp comes on and the lamp warning light  flashes orange. To maintain projector brightness and image quality, replace the lamp as soon as possible.
- The lamp warning light  flashes red (the lamp is burnt out).

Contact your dealer or call EPSON at (800) 873-7766 in the United States for a replacement lamp. Request part number V13H010L22. In Canada, please call (800) 463-7766 for dealer referral.

Follow these steps to replace the lamp and air filters:

1. Turn off the projector.
2. When the power light stops flashing, unplug the power cord.
3. Let the projector cool for at least half an hour (if it has been on). The lamp is extremely hot immediately after use.

### **note**

*When you get a replacement lamp for your projector, new air filters are included. You should replace the filters when you replace the lamp.*

*To order replacement air filters without the lamp, request part number V13H134A01.*

*To check how long the lamp has been in use, see page 173.*

### **warning**

*Let the lamp cool fully before replacing it.*

*In the unlikely event that the lamp has broken, small glass fragments may be present and should be removed carefully to avoid injury.*

4. Turn the projector over and remove the air filters at the side and bottom of the projector.

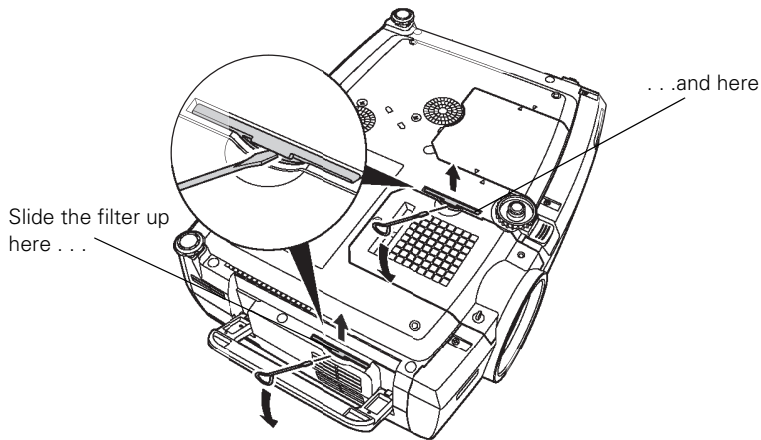

5. Insert the two new air filters. They should click into place.
6. Insert the screwdriver supplied with the spare lamp, or another flat-tipped screwdriver, into the space beside the air vent. Gently slide the lamp cover off.

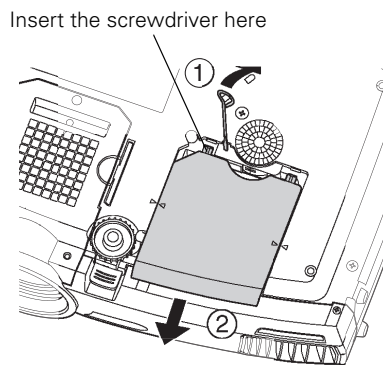

7. Loosen the two screws holding the lamp in place (you don't need to remove them).

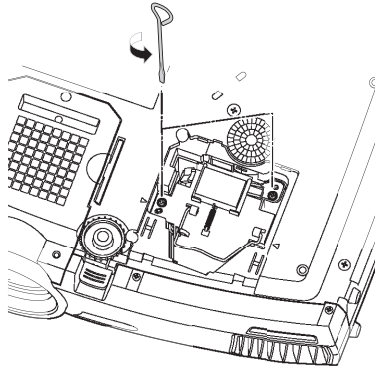

8. Grasp the wire handle as shown and pull the lamp straight out.

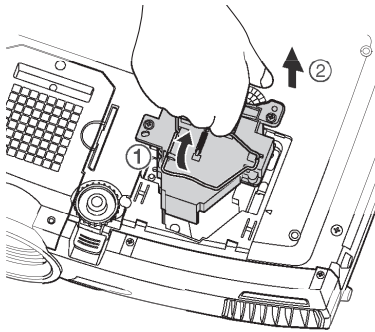

9. Gently insert the new lamp.
10. Once the lamp is fully inserted, tighten its screws and replace the cover. (The projector won't come on if the lamp cover is loose.)
11. Reset the lamp timer as described in the next section.

## Resetting the Lamp Timer

After you replace the lamp, you need to reset the lamp timer using the projector's menu.

1. Press the **Menu** button on the remote control (or on the projector's control panel). You see the main menu.
2. Use the  pointer button on the remote control (or the arrow buttons on the projector) to highlight **About**, then press **Enter**.

You see this screen:

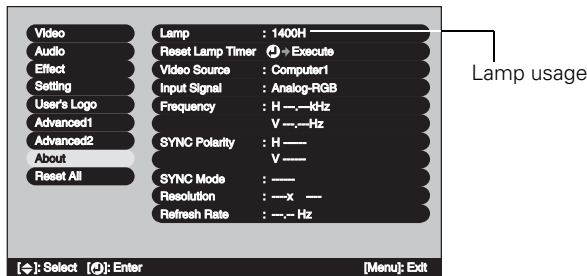

### **note**

*The lamp usage timer shows 0H until you've used the lamp for at least 10 hours.*

3. Select **Reset Lamp Timer**, then press **Enter**. You see this prompt:

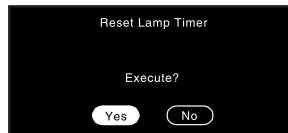

4. Select **Yes**, then press **Enter**.
5. When you're finished, press **ESC** or **Menu** to exit.

## *Transporting the Projector*

The projector contains many glass and precision parts. Follow these guidelines to prevent damage:

- When shipping the projector for repairs, use the original packaging material if possible. If you do not have the original packaging, use equivalent materials, placing plenty of cushioning around the projector.
- When transporting the projector a long distance, first place it in a hard-shell shipping case, and then pack it in a firm box, placing cushioning around the case. (An optional ATA molded hard shell case is available from EPSON; see page 14.)

---

**note**

*EPSON shall not be liable for any damages incurred during transportation.*

---

# 9 *Solving Problems*

This chapter helps you solve problems with your projector, and tells you how to contact technical support for problems you can't solve yourself. This chapter explains the following:

- Using the projector's on-screen help system
- What to do when the projector's status lights flash
- Solving problems with the image or sound
- Solving problems with EasyManagement
- Solving problems with the remote control
- Contacting technical support

## Using On-Screen Help

If the image doesn't look right or your audio isn't working, you can get help by pressing the blue ? Help button on top of the projector or on the remote control. The following choices are available:

- Help for the image
- Help for the sound
- Language selection (Language)

Follow these steps to get help:

1. Press the blue ? Help button on the projector.

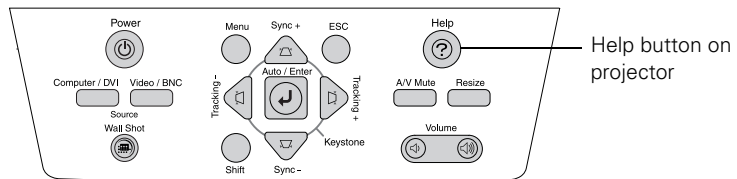

You see the Help menu:

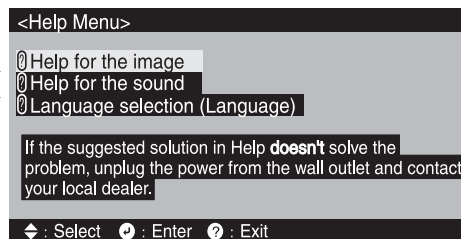

2. Use the  pointer button on the remote control or the arrow buttons on the projector to highlight menu items.
3. After highlighting a menu item, press the Enter button on the remote control or on the projector to select it.
4. To exit the Help system, press the ? Help button.

If none of the suggestions solves your problem, see additional solutions to problems in the following sections.



## Checking Projector Status

If your projector isn't working correctly, first turn it off, wait for it to cool (the  power light stops flashing orange), and unplug it. Then plug the power cord back in and turn on the projector. If this doesn't solve the problem, check the lights on top of the projector.



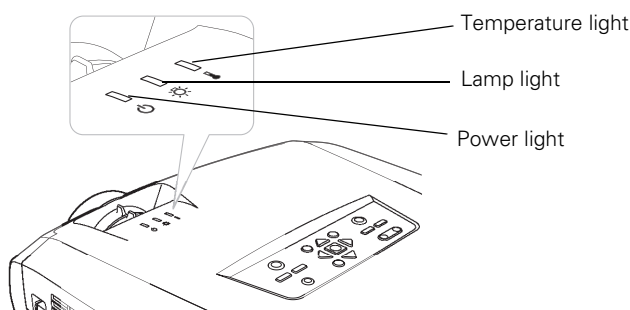

### What To Do When the Lights Flash

The lights on top of the projector indicate the projector's status and let you know when a problem occurs.







Refer to the following table for a complete description of the projector's status lights and their meaning:

#### Status lights

Light	Status	Description
	orange	The projector is in sleep mode. You can unplug it or press the <b>Power</b> button to turn it on.
	flashing green	The projector is warming up. Wait for the image to appear.
	green	The projector is operating normally.
	flashing orange	The projector is cooling down. You can't turn it back on (and you should not unplug it) until the light stops flashing and remains orange.
	flashing red	There is a problem with the fan or temperature sensor. Stop using the projector, disconnect the power cable, and contact EPSON or your dealer.

## Status lights

Light	Status	Description
	flashing orange	Rapid cooling in progress. Although this is not an abnormal condition, projection will stop automatically if the temperature rises higher. Make sure there is plenty of space around and under the projector for ventilation, and that the air filters and vents are clear.
	red	<p>The projector is overheating, which turns the lamp off automatically. Wait until the cooling fan stops, then unplug the power cord. Plug the power cord back in and press the Power button. Make sure the room temperature is not above 95 °F (35 °C) and there is plenty of space around and under the projector for ventilation.</p> <p>The air filters may be clogged. Clean or replace them as described on page 169.</p> <p>If the projector continues to overheat after you clean the air filter, the problem may be caused by damage to the cooling fan or temperature sensor. Contact EPSON for help.</p> <p><b>Warning:</b> Except as specifically explained in this <i>User's Guide</i>, do not attempt to service this product yourself.</p>
	flashing orange	It's time to replace the lamp. See page 170 for instructions. If you continue to use the lamp after the replacement warning, there is an increased possibility that the lamp may break.
	flashing red	The lamp may be burned out. First make sure the lamp cover is securely installed. If that's not the problem, remove the lamp and replace it as described on page 170. If this does not resolve the problem, contact EPSON as described on page 191.
	flashing red	Power is cut off because of an internal problem. Remove the power cord and contact EPSON for help, as described on page 191.

## Viewing Lamp Usage and Other Information

Use the About menu to view information about the display settings of your computer and the number of hours the lamp has been used.

1. Press the **Menu** button, then highlight the **About** menu and press **Enter**.

You see the lamp usage hours and various input signal settings on the right:

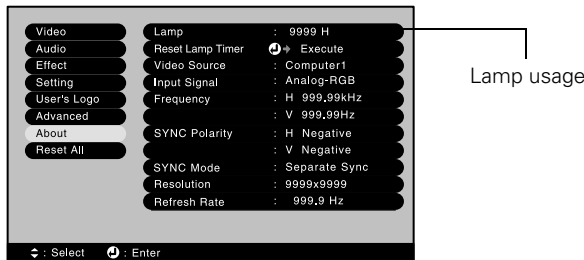



### **note**

*The information displayed depends on the input signal currently selected.*

The life span of the lamp is about 2000 hours if the **Brightness Control** setting in the Advanced 2 menu is set to **High** (default), and 3000 hours if the **Brightness Control** setting is set to **Low**. Make sure you have a spare lamp handy if the usage hours on this menu are close to the life span of your lamp. If you've installed a new lamp, be sure to reset the lamp timer (see page 173).

## *Solving Problems with the Image or Sound*

### **No image appears on the screen.**

- Check that the  power light is green, not flashing, and the lens cap is off.
- The projector may be in sleep mode. If the  power light is orange, press the **Power** button to turn the projector on.
- If the power was switched off and then on again, the projector may still be cooling down. Wait until the power light stops flashing and remains orange; then press the **Power** button again.
- Try pressing the other **Power** button on the remote control or on the projector.
- Press the **A/V Mute** button to make sure the picture has not been turned off temporarily.
- The attached computer may be in sleep mode or displaying a black screen saver. Try pressing a key on the computer.

### **You've connected a computer and see a blue screen with the message No Signal displayed.**

- Make sure the cables are connected correctly, as described in Chapter 3.
- Try restarting your computer.
- If you've connected a computer and one or more video sources, you may need to press one of the **Source** buttons on the projector or remote control to select the correct source. Allow a few seconds for the projector to sync up after pressing the button.

### If you're using a PC laptop:

- Hold down the Fn key on the keyboard and press the function key that lets you display on an external monitor. It may have an icon such as , or it may be labelled CRT/LCD. Allow a few seconds for the projector to sync up after pressing it. Check your laptop's manual or online help for details.

On most systems, the  key lets you toggle between the LCD screen and the projector, or display on both at the same time.

- Depending on your computer's video card, you might need to use the Display utility in the Control Panel to make sure that both the LCD screen and external monitor port are enabled. See your computer's documentation or online help for details.

### If you're using Macintosh OS X:

1. Open System Preferences.
2. Double-click Displays.
3. Make sure the VGA Display or Color LCD dialog box is selected.
4. Click the Arrange or Arrangement tab.
5. Make sure the Mirror Displays checkbox is selected.

### If you're using Macintosh OS 8.6 to 9.x:

1. From the Apple menu, select Control Panels, then click Monitors and Sound.
2. Click the Arrange icon.
3. Drag one monitor icon on top of the other. This lets you display on the projector screen as well as the LCD screen.
4. If this option isn't available, click the Monitor icon.
5. Select one of the listed Simulscan resolutions. (Allow a few seconds for the projector to sync up after making the selection.)

### **The message Not Supported is displayed.**

- Make sure the correct **Input Signal** is selected in the Setting menu (see page 137).
- Make sure your computer's resolution doesn't exceed UXGA (1600 × 1200), and the frequency is supported by the projector (see page 204). If necessary, change your computer's resolution setting as described on the following page.

### **Only part of the computer image is displayed.**

- Press the **Auto** button on the remote control.
- Make sure the image **Position** setting is correct on the Video menu. See Chapter 6 for more information.
- Make sure your computer's resolution setting is correct. Ideally, it should be 1024 × 768 to match the projector's native resolution. If this option isn't available, select one of the other compatible video formats listed on page 204.
  - **Windows:**  
Right-click the desktop, select **Properties**, click the **Settings** tab, and select a different resolution.
  - **Macintosh OS X:**  
Open **System Preferences**, double-click **Displays**, and then select a different resolution.
  - **Macintosh OS 8.6 to 9.x:**  
On the Apple menu, choose **Control Panels**, then click **Monitors and Sound**. Select a different resolution.
- You also may need to modify existing presentation files if you created them for a different resolution. See your software documentation for specific information.

## The image isn't square, but keystone-shaped.

- If the top or bottom of the image is broader, press the **Sync +** or **Sync -** button on the projector until the image is square.
- If the projector is angled toward the screen from the left or right, the image will be broader on one side. Center the projector in front of the middle of the screen, facing the screen squarely. If this doesn't work, press the **Tracking +** or **Tracking -** button on the projection until the image is square.
- If the image has no parallel sides, use **Quick Corner**. Press the **Menu** button, select the **Setting** menu, then select **Keystone**. Finally, select **Quick Corner** and make your adjustments with the  pointer button. See page 37 for details.

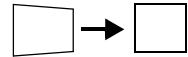
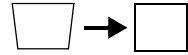

## The image contains static or noise.

- Make sure the correct **Input Signal** is selected in the **Setting** menu (see Chapter 6).
- If you're using a computer cable longer than 6 feet (2 meters), or an extension cable, the image quality may be reduced.
- Keep your computer and video cables away from the power cord as much as possible to prevent interference.
- The video signal may be split between the computer and the projector. If you notice a decline in the projected image quality when the image is displayed simultaneously on your laptop computer and the projector, turn off the laptop's LCD display.

## The image is blurry.

- There may be dirt or smears on the lens. Clean the lens as described on page 168.
- Adjust the focus using the focus ring.
- Make sure the lens is not fogged by condensation. You may need to wait before using the projector after moving it from a cold environment to a warm environment.

- Adjust the **Sharpness** setting on the Video menu (see Chapter 6). When you change video settings, you should be able to see the effect on the screen immediately. If you're projecting from a computer, you may also need to adjust the tracking and sync as described in the next section. If you don't like the new settings, you can always select **Reset** to return to the factory default settings.

**You see vertical bands, or the image still looks blurry after trying the solutions in the previous section.**

- If you're projecting from a computer and displaying an image that contains a lot of fine detail, you may notice one or more vertical bands, or some of the characters may look heavy or blurred. Press the **Auto** button on the remote control. This resets the projector's tracking and sync settings.
- If further adjustment is needed, you can fine-tune the **Tracking** and **Sync** settings manually using the Video menu as described in Chapter 6.
  1. Fill the screen with an image containing fine detail when making these adjustments. For example, in Windows you can select a pattern to appear as your desktop background. If this option isn't available, try projecting black text on a white background.
  2. Adjust the **Tracking** to eliminate vertical bands.

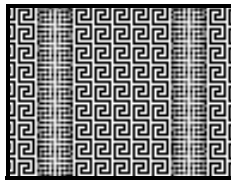



3. Adjust the **Sync** setting to increase the sharpness of the image.

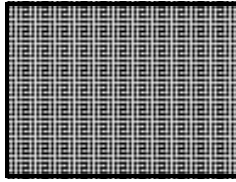

### **The colors of the image are not right.**

- If you're displaying a computer image, use the **Color Mode** option in the projector's Video menu to adjust the color. If you're displaying video, adjust the **Color**, **Tint**, and **Color Mode** settings on the Video menu.
- Try changing the **Color Adjustment** setting on the Advanced 1 menu.
- Check your computer display settings to correct the color balance.



---

#### **note**

*Because of the different technologies used, your projected image may not exactly match the colors on your laptop or computer monitor.*

---

### **There is no sound.**

- Make sure the **A/V Mute** button is not enabled.
- Try adjusting the **Volume** setting in the Audio menu (see page 131).
- If you're using a VCR or other video source, make sure the volume is not turned all the way down or muted. Also, make sure the cables are connected correctly, as described in Chapter 3.
- If your presentation includes computer audio, make sure the volume control on your computer is not turned all the way down or muted. If you're using the audio cable, make sure it is securely connected to both the projector and your computer's  headphone jack or  audio out jack.
- Make sure the Windows volume controls on your computer are not turned all the way down or set to Mute. You may be able to check this by clicking the volume control in your Windows System Tray (lower right corner of the screen).

## *Solving EasyManagement Problems*

### **You don't see your projector in the EMP Monitor window.**

- Make sure that you've connected the projector to the network and configured it correctly; see page 142 for information about setting up the projector for a wired network, or page 70 for information about setting it up for a wireless network. Also, make sure you've registered the projector with EMP Monitor. See page 144.
- Make sure that Standby Mode in the projector's Advanced 1 menu is set to **Network ON**.
- If the computer you are using is running Windows XP or 2000, you must be logged in as the Administrator.
- Try restarting your computer.

### **You can't connect to the projector using NS Connection.**

- Make sure you've installed the EPSON 802.11b card correctly in the projector; see page 68 for instructions. If you have to reinstall the card, restart NS Connection or the program will not be able to detect the projector.
- Make sure your projector and computer are configured correctly. See page 70 (Ad Hoc mode) or page 77 (Access Point mode) or details.
- Make sure that you have sufficient wireless signal strength (above 50 per cent). If you have a Macintosh, check the AirPort icon on the Macintosh menu bar. For Windows, see the documentation for your computer's wireless card or adapter for details.
- Make sure you aren't projecting one of the EasyMP configuration screens. (You should see a message that the projector is ready to connect.) If you have to exit a configuration screen, restart NS Connection.
- If the projector is configured for Access Point mode and you're using DHCP, allow a minute or two for your projector to appear. Sometimes it takes the server a little while to pick up the IP address.

- If you've changed any settings for your projector or network, or you've restarted your computer, allow a minute or two for the connection to appear. If you're using AirPort, you may have to turn AirPort off and then on again.
- Make sure that you're trying to connect to the right network. In Windows, verify that you've enabled your computer's connection to the access point (see page 85) or that your wireless card or adapter is enabled and its SSID is set to match the projector's ESSID (see page 75). In Macintosh, click the AirPort icon at the top of your Macintosh desktop to make sure AirPort is turned on and the projector's ESSID or your AirPort network is selected.
- If you have an access point or AirPort base station and you're not using DHCP, check your projector's IP address on the Access point mode advanced settings screen. The first three segments of the IP address should be identical to the first three segments of the IP address for your access point or base station. The last segment of the projector's IP address should be close, but not identical, to the last segment of the IP address for your access point or base station.
- If you're not using DHCP, check your projector's Gateway address on the projector's Access point mode advanced settings screen. It should be identical to the IP address for your access point or AirPort base station.
- If you're using a projector keyword, it changes each time you turn the projector off and then on again, or remove and reinsert the 802.11b wireless card. Check the projector's keyword on the EasyMP Network screen and enter it at the prompt.
- If you're using AirPort, check the configuration of your AirPort network. Start the AirPort Admin utility, select your base station, click **Configure**, then click **Show All Settings**. Finally, click the **Network** tab. If you set up your projector to connect in DHCP mode, **Distribute IP Addresses** and **Share a Single IP Address** should both be on.
- If you're using AirPort and DHCP is turned off on your projector's Access point mode advanced settings screen, make sure **Distribute IP Addresses** is deselected.

- If you're using Access Point mode and you're connecting to the wrong network, you may be experiencing signal interference from another network. Try resetting your access point or base station, then restart NS Connection.
- If you're using AirPort, the projector's ESSID should match the AirPort network name, not the name of the AirPort base station. To check the network name, start the AirPort Admin utility, select your base station, and click **Configure**. Then click **Show All Settings**. The network name appears on the AirPort tab.
- Try setting your AirPort Extreme card to operate in **802.11b only** mode. To access this setting, start the AirPort Admin utility, select your base station, click **Configure**, and then click **Show All Settings**. Finally, click the **Network** tab.
- If you're prompted for a password when you connect, enter the WEP encryption key if you're using WEP encryption.
- Try connecting using IP Connect Mode. See page 95 for instructions.
- Restart your computer.

### **An image displayed with EasyMP appears distorted.**

Because of their resolution, some JPEG images cannot be displayed correctly. Some JPEG files from digital cameras cannot be previewed. Files with a high compression ratio may appear blurry.

### **In EMP SlideMaker, PowerPoint files don't appear in the file window.**

EMP SlideMaker does not support PowerPoint 95. Files created in this version of PowerPoint must be opened and resaved in PowerPoint 97 or later.

**In EMP SlideMaker, your PowerPoint files don't display thumbnails and can't be pasted into scenarios.**

If you use PowerPoint 97, make sure the MS Office JPEG converter has been installed. Run the Office 97 installer, display the **Converts and Filters** option, and install the JPEG filter. Also, make sure PowerPoint is installed on the computer you're using to build the scenario.

**You can't edit scenario files in EMP SlideMaker after they have been transferred to the memory card.**

When scenario files are transferred, they are converted to the .SIT format. You can only edit scenarios before they are transferred (in the .SIC format). Open the scenario files saved on your hard drive, make any desired changes, then transfer the scenario again to your memory card.

**You can't transfer your slideshow to the memory card because you aren't able to see the card's drive letter.**

You must insert the memory card in your computer's PCMCIA slot before you select **Send Scenario** from the Scenario Option(s) menu. If you don't, you won't be able to see the card's drive in the drive selection window. If this happens, close and restart EMP SlideMaker. Make sure your card is inserted before you select **Send Scenario**.

**You can't play your movies on the projector.**

The projector only supports MPEG2 files. It does not support MPEG1 files.

**EasyMP is unable to see the image files on your camera.**

Make sure your camera shows up on your desktop as a drive letter when you connect it to your computer. If it does, it is probably a USB mounted device and will work with your projector. The projector does not support TWAIN-compliant digital cameras.

## *Solving Problems with the Remote Control*

### **The projector doesn't respond to remote control commands.**

- If you're using the remote control for the first time, be sure to push up on the ON/OFF switch, as shown on page 19.
- The remote control's batteries may not be installed correctly or may be low on power. To change the batteries, see page 34.
- Make sure your remote control's ID is set to 0, or to the projector's ID. See page 135.
- Make sure you are within about 30 feet (10 meters) of the projector, and within range of the projector's front or back sensor (approximately 30° to the left or right and 15° above or below).
- Dim the room lights and turn off any fluorescent lights. Make sure the projector is not in direct sunlight. Strong lighting, especially fluorescent lights, may affect the projector's infrared receivers. Also, turn off any nearby equipment that emits infrared energy, such as a radiant room heater.

## Where To Get Help

EPSON provides technical assistance through electronic support services 24 hours a day, as listed in the following table.

Service	Access
World Wide Web	From the Internet, you can reach EPSON's product support page at <a href="http://support.epson.com">http://support.epson.com</a> . After selecting your product, you can access troubleshooting information, download product documentation, and receive technical advice through e-mail.
Presenters Online	Access tips, templates, and training for developing successful presentations at <a href="http://www.presentersonline.com">http://www.presentersonline.com</a>

### Telephone Support Services

To use the EPSON PrivateLine Support service, call (800) 637-7661 and enter the PIN on the EPSON PrivateLine Support card included in your Start Here kit. This is the fastest way of speaking to a live representative, and it's free. This service is available 6 AM to 6 PM, Pacific Time, Monday through Friday, for the duration of your warranty period.

You may also speak with a projector support specialist by dialing one of these numbers:

- U.S.: (562) 276-4394, 6 AM to 6 PM, Pacific Time, Monday through Friday
- Canada: (905) 709-3839, 6 AM to 6 PM, Pacific Time, Monday through Friday

Toll or long distance charges may apply.

Before you call, please have the following information ready:

- Product name (EPSON PowerLite 7850p)
- Product serial number (located on the bottom of the projector)
- Computer configuration
- Description of the problem

You can purchase screens, carrying cases, or other accessories from EPSON at (800) 873-7766 or by visiting the EPSON Store at [www.epsonstore.com](http://www.epsonstore.com) (U.S. sales only). In Canada, please call (800) 463-7766 for dealer referral.





# A Software Installation

---

**note:**

*You can present over a wireless network from a Macintosh running OS X, but you can only monitor the projector from a remote location using a Windows system.*

---

The EasyMP software CD-ROM includes the software you need to use the projector's EasyMP features—for presenting over a wireless network, transferring PowerPoint presentations to a memory card, and monitoring the projector from a remote location.

---

## Windows System Requirements

Before you install the software, make sure your computer meets these requirements for projecting wirelessly:

- Microsoft Windows 98, 2000, Me, or XP
- 802.11b network card or wireless adapter (to use EMP NS Connection)
- IBM® compatible with at least a Pentium® III 700 MHz processor
- At least 256MB of RAM
- At least 128MB of free hard disk space
- SVGA (800 × 600) or better display adapter and monitor

## *Macintosh System Requirements*

Before you install the software, make sure your Macintosh meets the following requirements for projecting wirelessly:

- Macintosh OS X 10.2.4 or later
- AirPort(802.11b) or AirPort Extreme (802.11g) wireless network interface
- PowerMacintosh® series, iMac®, PowerBook®, or iBook® series system.
- At least 256MB of RAM
- At least 128MB of free hard disk space
- SVGA (800 × 600) or better display adapter and monitor

## Installing the Software on a Windows System

Depending on your needs, you may not need to install all the components. For example, you may just want to install EMP NS Connection on your laptop (to project wirelessly) and then install EMP Monitor on another system (to remotely monitor the projector).

Follow these steps:

1. Insert the EasyMP software CD-ROM in your computer's CD-ROM drive. You see this screen:

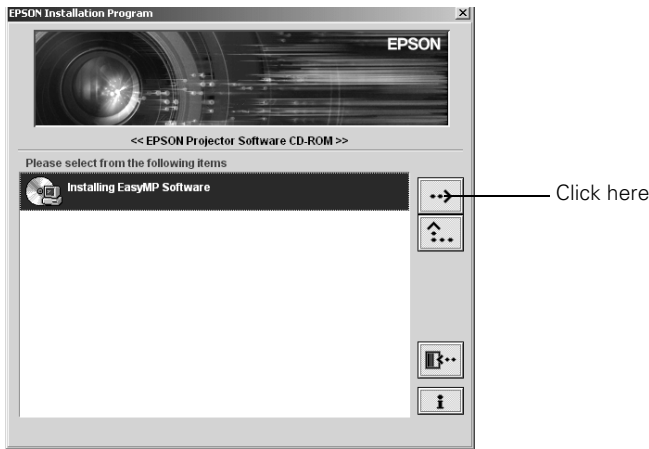

2. Click the  button to advance to the next screen.



3. If you want to project over a wireless network, make sure the option to install **EMP NS Connection** is highlighted, then click the  button. Follow the on-screen instructions.

When you see a message that the EPSON GDI Monitor Driver has not passed Windows Logo testing, click **Continue Anyway**.

4. To project images stored on a memory card, select the option for **EMP SlideMaker2** and install it the same way.
5. To monitor the projector remotely from this computer, select the option for **EMP Monitor** and install it the same way.
6. When done installing the software, click the  button to exit.

Once installed, you can access these programs from your computer's Start menu.

## *Installing the Software on a Macintosh*

Follow these steps to install EMP NS Connection:

1. Insert the NS Connection for Macintosh software CD-ROM in your drive. If necessary, double-click the **EPSON CD-ROM** icon to open its window.
2. Double-click the **EMP NS Connection.pkg** icon. The following screen displays:



3. Click **Continue**. You see the software license agreement.
4. Click **Continue**, then click **Agree**.
5. Select the destination drive, then click **Continue**. You see the following installation window:

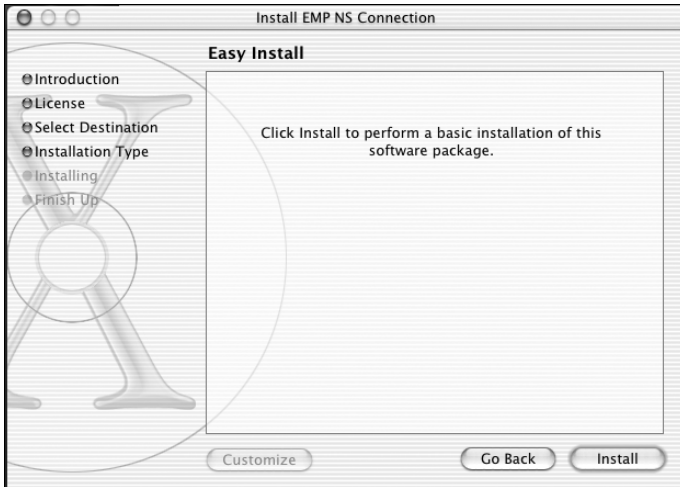

6. Click **Install**. When installation is complete, close the installation window.



# B *Projector Installation*

This appendix provides guidelines on installing the projector in a permanent location, such as a theater or conference room.

## *Installation Guidelines*

The projector can be installed for four different viewing setups: front projection, ceiling mounting, rear projection onto a semi-transparent screen, or rear/ceiling projection, as shown:

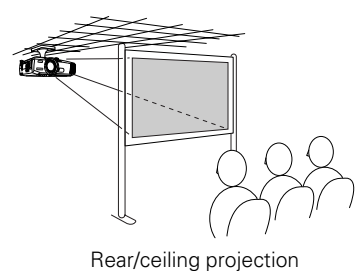
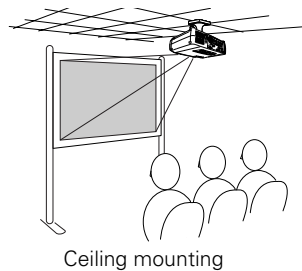
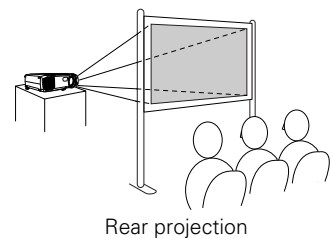
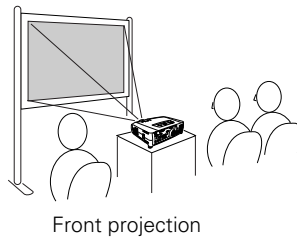

To project from overhead, you'll need the optional ceiling mounting hardware; see page 13 for ordering information. You'll also need to select **Ceiling** in the projector's Advanced 1 menu to flip the image upside-down. To project from the rear, select **Rear Proj** (see page 139).

If you're mounting the projector on the ceiling and you place it above screen level, you'll have to tilt it down to position the image on-screen. This causes the image to lose its square shape. You can then correct the distortion by using the **Keystone** function in the projector's menu system (see page 129) or by using the **Keystone** buttons on the projector's control panel.

If you place the projector so that the base of the lens is level with the bottom of the screen, the image will be square and you won't have to adjust it. If you place the lens lower than the bottom of the screen, you'll have to tilt the projector upward if you want to fill the whole screen with the image.

If you want to be able to control the projector's settings from a remote computer, see Chapter 7.

You can also use the remote control to operate more than one projector. See page 135.



# C *Technical Specifications*

## **General**

Type of display	Poly-silicon TFT active matrix
Size of LCD panels	Diagonal: 1.0 inch (25.4 mm)
Lens	F=1.7 to 2.3, f=28 to 37 mm
Resolution (native format)	1024 × 768 pixels (XGA)
Color reproduction	24 bit, 16.8 million colors
Brightness	3500 lumens (ANSI)*
Contrast ratio	700:1
Image size	30 to 300 inches
Projection distance	2.5 to 36.1 feet (0.8 to 11 meters)
Projection methods	Front, rear, upside-down (ceiling mount)
Internal sound system	5 W monaural
Optical aspect ratio	4:3 (horizontal:vertical)
Zoom ratio	1:1.35
Noise level	36 dB*
Keystone correction	Automatic (vertical only); manual adjustment capability ±40° (vertical), ±20° (horizontal)

\* Depends on the **Brightness Control** setting in the **Advanced 2** menu.

## ***Projection Lamp***

Type	UHE (Ultra High Efficiency)
Power consumption	250 W
Lamp life	Approx. 2000 hours (high brightness mode) Approx. 3000 hours (low brightness mode)
Part number	V13H010L22

## ***Remote Control***

Range	33 feet (10 meters)
Batteries (2)	Alkaline AA

## ***Mouse Compatibility***

Supports USB

## ***Dimensions***

Height	4.6 inches (117 mm), feet retracted
Width	16.5 inches (419 mm)
Depth	12.8 inches (325 mm)
Weight	12.8 lb (5.8 kg)

## ***Electrical***

Rated frequency	50/60 Hz AC
Power supply	100 to 120 VAC, 3.6 A 200 to 240 VAC, 1.6 A
Power consumption	Operating: 350 W Standby: 1.5 W with Network OFF 47 W with Network ON

## ***Environmental***

Temperature	Operating: 41 to 95 °F (5 to 35 °C) Storage: 14 to 140 °F (-10 to 60 °C)
Humidity	Operating: 20 to 80% RH, non-condensing  Storage: 10 to 90% RH, non-condensing

## ***Safety***

United States	FCC 47CFR Part 15B Class B (DoC) UL1950 Rev. 3
Canada	ICES-003 Class B CSA C22.2 No. 950-95 (cUL)
CE Marking	Directive 73/23/EEC Directive 89/336/EEC EN 55022, EN 55024



Pixelworks™ DNX™ ICs are used in this projector.

## Compatible Video Formats

The projector supports NTSC, PAL, and SECAM international video standards, as well as the monitor display formats listed below.

To project images output from a computer, the computer's video card must be set at a refresh rate (vertical frequency) that's compatible with the projector; see the following table for compatible formats. As noted below, some images are automatically resized to display in the projector's "native" format (XGA). In addition, the frequencies of some computers may not allow images to display correctly; see your computer's documentation for details.

Mode	Refresh Rate (Hz)	Resolution
VGAEGA	70	640 × 350*
VGA—60	60	640 × 480*
VESA—72	72	640 × 480*
VESA—75	75	640 × 480*
VESA—85	85	640 × 480*
SVGA—56	56	800 × 600*
SVGA—60	60	800 × 600*
SVGA—72	72	800 × 600*
SVGA—75	75	800 × 600*
SVGA—85	85	800 × 600*
XGA—60	60	1024 × 768
XGA—70	70	1024 × 768
XGA—75	75	1024 × 768
XGA—85	85	1024 × 768
XGA—100	100	1024 × 768
XGA—120	120	1024 × 768
SXGA1—70	70	1152 × 864*
SXGA1—75	75	1152 × 864*
SXGA1—85	85	1152 × 864*
SXGA1—100	100	1152 × 864*
SXGA2—60	60	1280 × 960*
SXGA2—75	75	1280 × 960*
SXGA2—85	85	1280 × 960*
SXGA3—60	60	1400 × 1050*
SXGA3—75	75	1400 × 1050*
SXGA3—85	85	1400 × 1050*

<b>Mode</b>	<b>Refresh Rate (Hz)</b>	<b>Resolution</b>
UXGA—60	60	1600 × 1200*
UXGA—65	65	1600 × 1200*
UXGA—70	70	1600 × 1200*
UXGA—75	75	1600 × 1200*
UXGA—80	80	1600 × 1200*
UXGA—85	85	1600 × 1200*
MAC13	67	640 × 480*
MAC16	75	832 × 624*
MAC19	75	1024 × 768
MAC21	75	1152 × 870*
NTSC	60	—
NTSC 4:43	60	—
PAL	50	—
N-PAL	50	—
M-PAL	60	—
PAL—60	60	—
SECAM	50	—
HDTV (720p)	60	1024 × 576*
HDTV (1080i)	60	1024 × 576*
SDTV (480i)	60	1024 × 768
SDTV (480p)	60	1024 × 768
SDTV (625i)	50	1024 × 768
SDTV (625p)	50	1024 × 768

\*The image is resized using EPSON's SizeWise™ Technology.



# D

## Notices

This appendix includes safety instructions and other important information about your EPSON PowerLite projector.

### *Important Safety Instructions*

Follow these safety instructions when setting up and using the projector:

- Do not place the projector on an unstable cart, stand, or table.
- Do not use the projector near water or sources of heat.
- Use the type of power source indicated on the projector. If you are not sure of the power available, consult your dealer or power company.
- Place the projector near a wall outlet where the plug can be easily unplugged.

*Placez l'appareil près d'une prise de courant où la fiche peut être débranchée facilement.*

- Insert the projector's three-wire grounding-type plug into a properly grounded outlet. If you have a two-prong outlet, contact an electrician to replace it. Do not hold the plug with wet hands.
- Take the following precautions for the plug. Failure to comply with these precautions could result in sparks or fire: Do not insert the plug into an outlet with dust present. Insert the plug firmly into the outlet.
- Do not overload wall outlets, extension cords, or integral convenience receptacles. This can cause fire or electric shock.
- Do not place the projector where the cord can be walked on. This may result in fraying or damage to the plug.
- Unplug the projector from the wall outlet before cleaning. Use a damp cloth for cleaning. Do not use liquid or aerosol cleaners.
- Do not block the slots and openings in the projector case. They provide ventilation and prevent the projector from overheating. Do not operate the projector on a sofa, rug, or other soft surface, or in a closed-in cabinet unless proper ventilation is provided.

- Never push objects of any kind through the cabinet slots. Never spill liquid of any kind into the projector.
- Except as specifically explained in this *User's Guide*, do not attempt to service this product yourself. Refer all servicing to qualified personnel. Opening or removing covers may expose you to dangerous voltages and other hazards.
- Unplug the projector from the wall outlet and refer servicing to qualified service personnel under the following conditions: When the power cord or plug is damaged or frayed. If liquid has been spilled into the projector, or if it has been exposed to rain or water. If it does not operate normally when you follow the operating instructions, or if it exhibits a distinct change in performance, indicating a need for service. If it has been dropped or the housing has been damaged.
- This product includes a lamp component that contains mercury. Please consult your state and local regulations regarding proper disposal and do not place in the trash.
- Unplug the projector during lightning storms or when it will not be used for extended periods.
- Do not place the projector and/or remote control on top of heat-producing equipment or in a hot location.
- If you use the projector in a country other than where you purchased it, use the correct power cord for that country.
- Do not stand on the projector or place heavy objects on it.
- Do not use the projector outside of the required temperature range of 41 to 95 °F (5 to 35 °C). Doing so may cause an unstable display and could lead to projector damage.
- Do not store the projector outside of the required temperature range of 14 to 140 °F (-10 to 60 °C) or in direct sunlight for long periods of time. Doing so may cause damage to the case.



## *Remote Control Information*

You can operate the projector by remote control via a line-of-sight infrared (IR) receiver at the front and rear of the projector. The projector may not respond to remote control commands under the following conditions:

- There is an object between the remote control IR emitter and the IR receiver on the projector.
- Ambient light is too bright.
- Certain types of fluorescent lighting are used.
- A strong light source shines into the IR receiver.
- Other equipment that emits infrared energy, such as a radiant room heater, is in the room.

These conditions commonly cause problems for most infrared-controlled equipment. Try the following:

- The remote control's batteries may be low on power; replace them.
- Dim the ambient lighting and/or turn off any fluorescent lights.
- Close any window coverings and/or move the projector out of direct sunlight.
- Turn off other equipment that emits infrared energy.

## *Declaration of Conformity*

According to 47CFR, Part 2 and 15, Class B Personal Computers and Peripherals; and/or CPU Boards and Power Supplies used with Class B Personal Computers

We: EPSON AMERICA, INC.  
Located at: 3840 Kilroy Airport Way  
MS: 3-13  
Long Beach, CA 90806-2469  
Telephone: (562) 290-5254

Declare under sole responsibility that the product identified herein, complies with 47CFR Part 2 and 15 of the FCC rules as a Class B digital device. Each product marketed, is identical to the representative unit tested and found to be compliant with the standards. Records maintained continue to reflect the equipment being produced can be expected to be within the variation accepted, due to quantity production and testing on a statistical basis as required by 47CFR §2.909. Operation is subject to the following two conditions: (1) this device may not cause harmful interference, and (2) this device must accept any interference received, including interference that may cause undesired operation.

Trade Name: EPSON  
Type of Product: Projector  
Model: EMP-7850  
Marketing Name: PowerLite 7850p

# *FCC Compliance Statement*

## **For United States Users**

This equipment has been tested and found to comply with the limits for a Class B digital device, pursuant to Part 15 of the FCC Rules. These limits are designed to provide reasonable protection against harmful interference in a residential installation. This equipment generates, uses, and can radiate radio frequency energy and, if not installed and used in accordance with the instructions, may cause harmful interference to radio or television reception. However, there is no guarantee that interference will not occur in a particular installation. If this equipment does cause interference to radio and television reception, which can be determined by turning the equipment off and on, the user is encouraged to try to correct the interference by one or more of the following measures:

- Reorient or relocate the receiving antenna.
- Increase the separation between the equipment and receiver.
- Connect the equipment into an outlet on a circuit different from that to which the receiver is connected.
- Consult the dealer or an experienced radio/TV technician for help.

## **WARNING**

The connection of a non-shielded equipment interface cable to this equipment will invalidate the FCC Certification of this device and may cause interference levels which exceed the limits established by the FCC for this equipment. It is the responsibility of the user to obtain and use a shielded equipment interface cable with this device. If this equipment has more than one interface connector, do not leave cables connected to unused interfaces. Changes or modifications not expressly approved by the manufacturer could void the user's authority to operate the equipment.

## **For Canadian Users**

This Class B digital apparatus meets all requirements of the Canadian Interference-Causing Equipment Regulations.

*Cet appareil numérique de la classe B respecte toutes les exigences du Règlement sur le matériel brouilleur du Canada.*

# Warranty

## **Epson America, Inc. Limited Warranty**

### Basic Two-Year Warranty and 90-Day Lamp Warranty

*What Is Covered:* Epson America, Inc. (“EPSON”) warrants to the first end user customer of the EPSON product enclosed with this limited warranty statement that the product, if purchased and used in the United States or Canada, conforms to the manufacturer’s specifications and will be free from defects in workmanship and materials for a period of two (2) years from the date of original purchase (except that the warranty period is 90 days for projector lamps).

*What EPSON Will Do To Correct Problems:* If you elect carry-in warranty service, please bring the product securely packaged in its original container or an equivalent, along with proof of the date of original purchase, to your EPSON Dealer or EPSON Customer Care Center. EPSON will, at its option, repair or replace on an exchange basis the defective unit, without charge for parts or labor. When warranty service involves the exchange of the product or of a part, the item replaced becomes EPSON property. The exchanged product or part may be new or previously repaired to the EPSON standard of quality. Exchange or replacement products or parts assume the remaining warranty period of the product covered by this limited warranty. However, each replacement lamp carries the limited 90-day warranty stated above.

*What This Warranty Does Not Cover:* This warranty covers only normal consumer use in the United States and Canada. For lamps, 24-hour-per-day use causes unusual strain and is not considered normal use. This warranty does not cover consumables (e.g., fuses), other than lamps. EPSON is not responsible for warranty service should the EPSON label or logo or the rating label or serial number be removed or should the product fail to be properly maintained or fail to function properly as a result of misuse, abuse, improper installation, neglect, improper shipping, damage caused by disasters such as fire, flood, and lightning, improper electrical current, software problems, interaction with non-EPSON products, or service other than by an EPSON Authorized Servicer. Postage, insurance, or shipping costs incurred in presenting your EPSON product for carry-in warranty service are your responsibility. If a claimed defect cannot be identified or reproduced in service, you will be held responsible for costs incurred.

THE WARRANTY AND REMEDY PROVIDED ABOVE ARE EXCLUSIVE AND IN LIEU OF ALL OTHER EXPRESS OR IMPLIED WARRANTIES INCLUDING, BUT NOT LIMITED TO, THE IMPLIED WARRANTIES OF MERCHANTABILITY OR FITNESS

FOR A PARTICULAR PURPOSE. SOME LAWS DO NOT ALLOW THE EXCLUSION OF IMPLIED WARRANTIES. IF THESE LAWS APPLY, THEN ALL EXPRESS AND IMPLIED WARRANTIES ARE LIMITED TO THE WARRANTY PERIOD IDENTIFIED ABOVE. UNLESS STATED HEREIN, ANY STATEMENTS OR REPRESENTATIONS MADE BY ANY OTHER PERSON OR FIRM ARE VOID. EXCEPT AS PROVIDED IN THIS WRITTEN WARRANTY, NEITHER EPSON AMERICA, INC. NOR ITS AFFILIATES SHALL BE LIABLE FOR ANY LOSS, INCONVENIENCE, OR DAMAGE, INCLUDING DIRECT, SPECIAL, INCIDENTAL OR CONSEQUENTIAL DAMAGES, RESULTING FROM THE USE OR INABILITY TO USE THE EPSON PRODUCT, WHETHER RESULTING FROM BREACH OF WARRANTY OR ANY OTHER LEGAL THEORY. IF THE REMEDY ABOVE FAILS, EPSON'S ENTIRE LIABILITY SHALL BE LIMITED TO A REFUND OF THE PRICE PAID FOR THE EPSON PRODUCTS COVERED BY THIS LIMITED WARRANTY.

In Canada, warranties include both warranties and conditions.

Some jurisdictions do not allow limitations on how long an implied warranty lasts and some jurisdictions do not allow the exclusion or limitation of incidental or consequential damages, so the above limitations and exclusions may not apply to you.

This warranty gives you specific legal rights, and you may also have other rights, which vary from jurisdiction to jurisdiction.

To locate the Authorized EPSON Servicer nearest you, call the EPSON Connection<sup>SM</sup> at (800) 637-7661 + PIN or (562) 276-4394 in the U.S. and (905) 709-3839 in Canada or write to: Epson America, Inc., P.O. Box 93012, Long Beach, CA 90809-3012.



# Index

## A

- A/V Mute, 38, 134, 180
- About menu, 173, 179
- Access Point mode, 77 to 89, 95 to 98
- Access point, checking IP address of, 86 to 87
- Accessories, 14, 191
- Ad Hoc mode, 70 to 76
- Adapter, Macintosh, 14, 55
- Air filter
  - cleaning, 169 to 170
  - ordering, 14
  - replacing, 170 to 171
- AirPort, configuring for wireless, 75 to 76, 87 to 89
- Anti-theft device, 14, 17
- Aspect ratio, 201
- ATA flash cards, 111
- Audio
  - adjusting volume, 131
  - connecting equipment, 65 to 66
  - menu, 131
  - problems, troubleshooting, 185
  - turning off (using A/V Mute), 38
  - using with scenarios, 105
- Auto button, 28
- Autorun setting, 112

## B

- Background color setting, 105
- Bands, vertical, 184
- Bass, adjusting, 131
- Batteries, installing, 34
- Blank screen, 21 to 23
- Blurry image, 183 to 184
- Brightness, 201
- Brightness setting, 126, 128
- Browser, monitoring projectors with, 156 to 157

## C

- Cables
  - BNC, 51, 53
  - DVI, 14, 54
  - illustrations, 12
  - mouse, 56
  - ordering, 14
  - remote control cable set, 14
  - S-video, 14, 60
  - VGA-to-component, 51
- Camera, *see* Digital camera
- Capturing image, 132 to 133
- Carrying case, 14, 174
- Ceiling mount, 14, 199 to 200
- Channel ad hoc, 72
- Cleaning
  - air filter, 169 to 170
  - lens, 168
  - projector case, 168
- Color
  - correcting with Wall Shot, 43 to 44
  - problems, 185
  - settings, 130
- Color Mode setting, 130
- CompactFlash memory cards, 111
- Component video
  - cable, 14, 58
  - selecting input signal, 61
- Composite (RCA) video cable, 58 to 59
- Computer
  - connecting to, 50 to 55
  - correcting images, 28
  - selecting source, 20
- Connecting projector
  - to a computer, 50 to 55
  - to a digital camera, 64
  - to an external monitor, 57
  - to audio equipment, 65 to 66
  - to video equipment, 58 to 63

Continuous play setting, 112, 119  
Contrast setting, 126, 128

## D

Declaration of Conformity, 210  
Default settings, restoring, 125  
Desktop adapter, Macintosh, 14, 55  
DHCP, 79, 85, 88, 187  
Digital camera  
    connecting to, 64  
    projecting images from, 120 to 121  
Display order setting, 119  
Distance from projector to screen, 16, 201  
Documentation, 10  
DVD player, connecting, 58 to 63  
DVI cable, 14, 54  
DVI port, connecting to, 54

## E

EasyManagement  
    configuring the projector, 70 to 73,  
        77 to 81, 142 to 143  
    installing software, 193 to 197  
    monitoring the projector, 144 to 151  
    problems, 186 to 189  
    receiving e-mail alerts, 152 to 155  
EasyMP  
    e-mail alerts, setting up, 152 to 155  
    problems, 188 to 189  
    software, 193 to 197  
    starting, 68 to 69  
    web browser, monitoring projector with,  
        156 to 157  
Electrical specifications, 202  
E-mail alerts, 152 to 155  
EMP Monitor  
    changing monitoring interval, 151  
    installing software, 195 to 196  
    problems, 186  
    using, 144 to 151

EMP NS Connection  
    configuring projector for, 77 to 81  
    creating password for, 72, 79  
    disconnecting, 93  
    encrypting presentation, 92  
    entering keyword, 92  
    installing software, 195 to 197  
    problems, 186 to 188  
    projecting wirelessly, 67 to 98  
    switching between users, 98  
    using, 89 to 98  
EMP SlideMaker  
    checking scenarios, 110  
    converting PowerPoint files, 102 to 103  
    creating scenarios, 102 to 109  
    installing software, 195 to 196  
    problems, 188 to 189  
    setting up transitions, 108 to 109  
    transferring scenarios to memory card,  
        111 to 112  
Encryption, 75, 80 to 81, 83, 92  
Environmental specifications, 203  
EPSON  
    accessories, 14, 191  
    presentation tips, 10  
    PrivateLine Support, 10, 191  
    technical support, 10, 191  
ESSID, 72, 75, 79, 83, 88, 91, 187  
Exporting projector groups, 163 to 164  
E-Zoom button, 39

## F

FCC compliance statement, 211  
Filter, *see* Air filter  
Focusing image, 24  
Freeze button, 38

## G

Gateway address, checking, 86  
Group, saving menu settings as, 128



- Groups, projector
  - connecting to, 161 to 163
  - creating, 158 to 160
  - exporting, 163 to 164
  - importing, 165 to 166

## H

- HDTV images, video formats, 205
- Height of image, adjusting, 25
- Help system, using, 176
- Help, EPSON, 10, 191
- HP OpenView, 79, 141

## I

- ID setting, 135 to 136
- Image
  - adjusting, 24 to 28, 126 to 130
  - blurry, 183 to 184
  - capturing and saving in projector,
    - 132 to 133
  - correcting shape, 26 to 27, 37, 129, 183
  - fitting on screen, 182
  - height, adjusting, 25
  - problems with, 180 to 185
  - projecting on walls, 43 to 44
  - raising, 25
  - rotating, 116, 121
  - selecting source, 20, 35 to 36, 52, 53, 54, 59, 60, 61, 62, 63, 137 to 138
  - size and projection distance, 16, 201
  - turning off (using A/V Mute), 38
  - zooming, 24, 39
- Importing projector groups, 165 to 166
- Infrastructure mode, *see* Access Point mode
- Input signal, selecting, 20, 35 to 36, 52, 53, 54, 59, 60, 61, 62, 63, 137 to 138
- Installing projector, 199 to 200
- Installing software, 193 to 197
- IP Connect Mode, 95 to 97

## K

- Kensington anti-theft device, 14, 17
- Keystone correction, 26 to 27, 129, 183, 201
- Keyword, 72, 79, 92

## L

- Lamp
  - number of hours used, 179
  - ordering, 14
  - replacing, 170 to 173
  - specifications, 202
  - status light, 177 to 178
- Lamp timer, resetting, 173
- Language setting, 139, 176
- Laptop computer
  - connecting to, 51 to 52
  - display problems, 21 to 23, 180 to 181
  - selecting source, 20, 52, 53, 54
- Lens
  - cleaning, 168
  - optional, 14
  - specifications, 201
- Lights, status, 177 to 178
- Logo, saving on projector, 132 to 134

## M

- Macintosh desktop adapter, 14, 55
- Manuals, 10
- Memory card
  - compatible card types, 111
  - inserting in projector, 113
  - removing from projector, 114
  - transferring scenarios to, 111 to 112
- Memory Stick, 111
- Menus
  - About, 173, 179
  - Audio, 131
  - changing settings, 124 to 125
  - default settings, restoring, 125
  - User's Logo, 132 to 133
  - Video, 126 to 128
- Microdrive, 111
- Monitor, connecting external, 57

Monitoring projector  
  EMP Monitor, 144 to 151  
  HP OpenView, 141  
  receiving e-mail alerts, 152 to 155  
  remote setup options, 138  
  web browser, 156 to 157  
Mouse  
  connecting cable for remote, 56  
  using remote control as, 44 to 45  
Movie files, using in scenarios, 106 to 108

## N

Network  
  managing projector remotely, 141 to 155  
  setting, 138, 147, 149  
  wireless, 67 to 99  
Network card, 193  
Network settings, configuring, 70 to 73,  
  77 to 81, 142 to 143, 152 to 155  
New Hardware Wizard, 19  
No Signal message, 21, 139, 180 to 181  
Noise level, 201  
NS Connection, *see* EMP NS Connection  
Numeric keypad, using, 46, 72

## O

Optical aspect ratio, 201  
Options for projector, 14

## P

Password for remote access, 72, 79  
Password protection, 45 to 47  
PC card, 111  
PCMCIA slot, 111  
Picture source, selecting, 20, 35 to 36, 52, 53,  
  54, 59, 60, 61, 62, 63, 137 to 138  
Picture, *see* Image  
P-in-P image, 39 to 40  
Pointer tool, using, 41 to 42  
Positioning  
  image, 25  
  projector, 16 to 17

Power  
  button, 19  
  specifications, 202  
  status light, 19, 177 to 178

PowerPoint files  
  adding slides to a scenario, 106 to 107  
  converting to scenarios, 102 to 103  
  presenting, 115 to 116  
  problems, 188 to 189

Presentations  
  computer, 20, 28, 50 to 56  
  digital camera, 64, 120 to 121  
  room conditions, 32  
  tips and training, 10  
  using the pointer tool, 41 to 42  
  video, 20, 58 to 63  
  wireless, 67 to 98

Presenters Online, 10, 191

Preset setting, 128

PrivateLine Support, 10, 191

Problems  
  color, 185  
  connecting wirelessly, 91, 186 to 188  
  image, 180 to 185  
  monitoring projector, 186  
  no signal, 21, 180 to 181  
  remote control, 190  
  scenarios, 188 to 189  
  sound, 185  
  using on-screen help, 176

Projecting without screen, 43 to 44

Projection lamp, *see* Lamp

Projector

- carrying case, 14, 174
- cleaning, 168
- connections, *see* Connecting projector
- distance from screen, 16, 201
- groups, 158 to 166
- ID, setting, 135
- installing, 199 to 200
- lamp specifications, 202
- monitoring remotely, 138, 141 to 157
- multiple projectors, controlling, 135 to 136
- options, 14
- password protection, 45 to 47
- positioning, 16 to 17
- resolution, 201
- specifications, 201 to 203
- transporting, 174
- troubleshooting, 175 to 178
- turning off, 29
- turning on, 18 to 19
- unpacking, 12
- viewing information about, 179

## Q

Quick Corner, 37

## R

Raising image, 25  
Rear-screen projection, 139, 199 to 200  
Registration, 11

Remote control

- A/V Mute button, 38
- as wireless mouse, 44 to 45
- battery used, 202
- checking ID, 136
- connecting cable for mouse, 56
- correcting color, 43 to 44
- E-Zoom button, 39
- Freeze button, 38
- information, 209
- numeric keypad, using, 46, 72
- pointer tool, using, 41 to 42
- problems, 190, 209
- range, 202
- replacing batteries, 34
- running slideshow with, 115 to 116
- setting ID, 136
- specifications, 202
- storing, 32
- switching sources, 35 to 36
- troubleshooting, 190
- turning on, 19, 32
- using navigation buttons, 33

Removing

- memory card, 114
- wireless card, 99

Replacing lamp, 170 to 173  
Resetting lamp timer, 173  
Resetting menu options, 125  
Resize image, 129  
Resolution, 128, 201  
Rotating the image, 116, 121

## S

Safety

- instructions, 207 to 208
- specifications, 203

- Scenarios
  - adding movie files, 106 to 108
  - adding sound, 105
  - background color, 105
  - cells, 103, 107
  - converting PowerPoint files, 102 to 103
  - creating, 102 to 109
  - default location, 105
  - editing on the projector, 116 to 120
  - exiting, 116
  - presenting on the projector, 115 to 116
  - previewing, 110
  - problems, 188 to 189
  - rearranging, 107
  - running automatically, 112
  - transferring to memory card, 111 to 112
  - transitions, 108 to 109
- Screen
  - blank, 21 to 23
  - distance from projector, 16
  - ordering, 14
  - startup screen, creating, 132 to 133
- Screen image, *See* Image
- Screen switching time setting, 119
- Security
  - Kensington lock, 14
  - password protection, 45 to 47
- Sharpness setting, 127, 128
- Sleep mode, 29, 139
- SlideMaker, *see* EMP SlideMaker
- Slides
  - displaying on the fly, 118 to 120
  - hiding, 116 to 117
  - rearranging, 116 to 117
- SmartMedia cards, 111
- SNMP, 141, 142
- Software installation, 193 to 197
- Sound
  - adding to scenarios, 105
  - adjusting, 131
  - troubleshooting, 185
- Source
  - selecting, 20, 35 to 36, 137 to 138
  - viewing, 179
- Speaker, specifications, 201
- Speakers, connecting, 66
- Special effects, adding to slide transitions, 109, 119
- Specifications
  - brightness, 201
  - dimensions, 202
  - electrical, 202
  - environmental, 203
  - general, 201
  - lamp, 202
  - lens, 201
  - remote control, 202
  - resolution, 201
  - safety, 203
- SSID, *see* ESSID
- Standby Mode setting, 138, 147, 149
- Startup screen, creating, 132 to 134
- Status lights, 177 to 178
- Support, *see* Technical support
- S-video cable, 14
- Switching between users, 98
- Switching picture source, 20, 35 to 36, 137 to 138
- Sync setting, 128
- Synchronization, adjusting, 28, 184 to 185

## T

- Technical support, 10, 191
- Temperature
  - requirements, 203
  - status light, 177 to 178
- Thumbnails, scenario, 106
- Tint setting, 127
- Tracking, adjusting, 28, 184 to 185
- Transitions, scenario, 108 to 109
- Transporting projector, 174
- Trap IP address, 79
- Treble, adjusting, 131

## Troubleshooting

- blank screen, 21 to 23, 180 to 181
- cut-off image, 182
- distorted image, 26 to 27
- EasyManagement, 186 to 189
- image and sound problems, 180 to 185
- no signal, 21, 180 to 181
- projector problems, 175 to 178
- remote control problems, 190
- wireless projection problems, 91, 186 to 188

Turning off picture (using A/V Mute), 38

Turning off projector, 29

## U

Unpacking projector, 12

USB cable, 12, 56

User's Logo menu, 132 to 133

## V

VCR, connecting, 58 to 63

### Video

- cables, 12, 14, 58
- connecting video equipment, 58 to 63
- display settings, viewing, 179
- formats, supported, 204 to 205
- menu, 126 to 128
- selecting source, 20, 35 to 36, 59, 60, 61, 137 to 138

Volume, adjusting, 131

## W

Wall Shot, 43 to 44

Warning lights, 177 to 178

Warranty, 11, 212 to 213

Web browser, monitoring projector with,  
156 to 157

WEP encryption, 80 to 81

Windows, configuring for wireless, 73 to 75,  
81 to 86

### Wireless

connecting manually, 95 to 97

e-mail alerts, 152 to 155

network card, 68, 99, 193

presentation, 67 to 98

problems, 186 to 188

projector groups, 158 to 166

WEP encryption, 80 to 81

Wireless, mouse, 44 to 45, 56

## Z

Zoom ratio, 201

Zooming image, 24, 39



## Front/Top

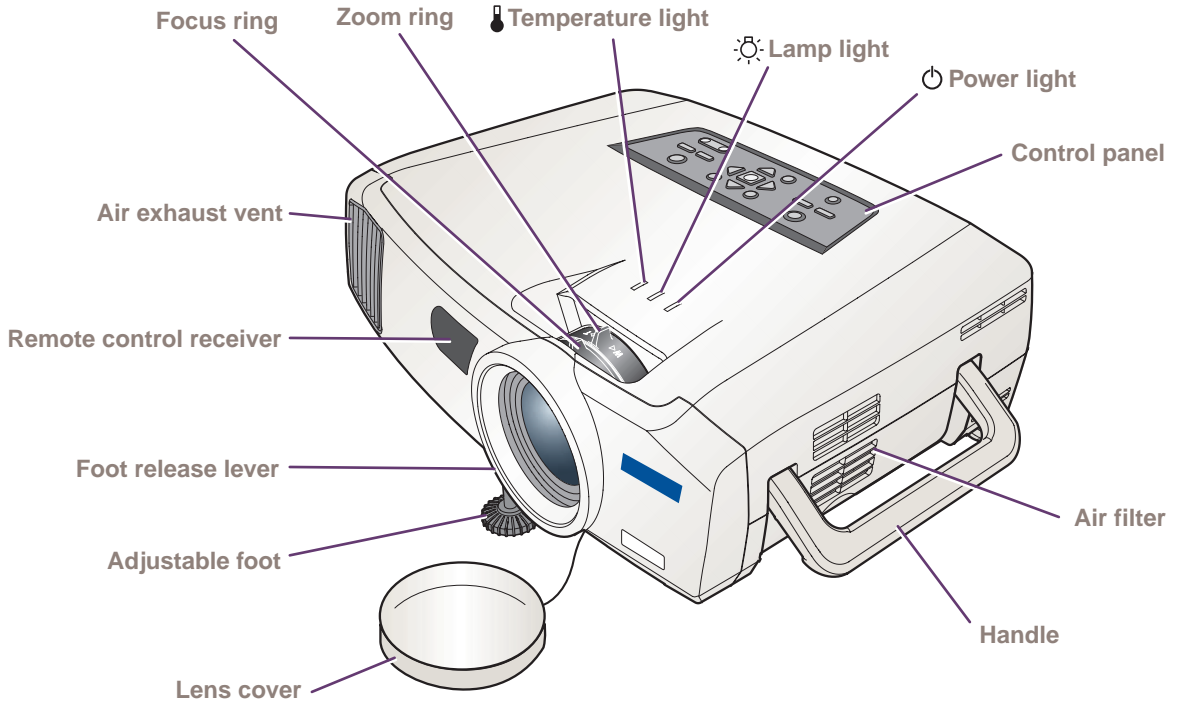

## Back

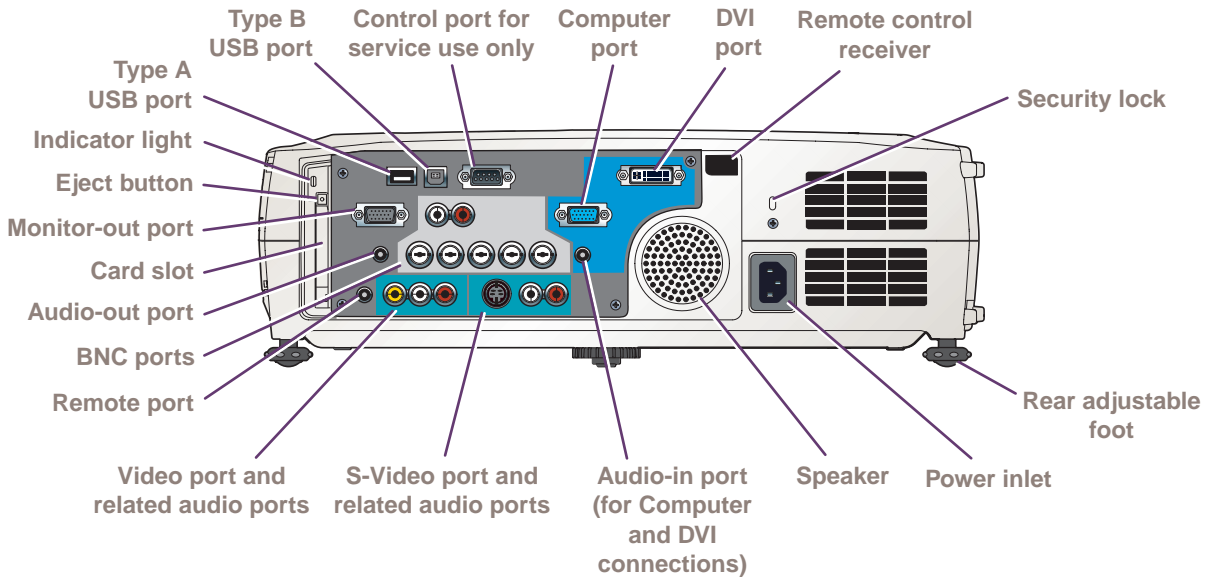

# Remote Control

