

iD PRO R600/R600+



Owners Manual

R9010350
R9010351

Product revision

Software version: V1.30

Barco nv Presentations
Noordlaan 5, 8520 Kuurne
Phone: +32 56.36.82.11
Fax: +32 56.35.86.51
E-mail: presentations.bid@barco.com
Visit us at the web: www.barco.com

Printed in Belgium

Copyright ©

All rights reserved. No part of this document may be copied, reproduced or translated. It shall not otherwise be recorded, transmitted or stored in a retrieval system without the prior written consent of Barco.

Federal Communications Commission (FCC Statement)

This equipment has been tested and found to comply with the limits for a class A digital device, pursuant to Part 15 of the FCC rules. These limits are designed to provide reasonable protection against harmful interference when the equipment is operated in a commercial environment. This equipment generates, uses, and can radiate radio frequency energy and, if not installed and used in accordance with the instruction manual, may cause harmful interference to radio communications. Operation of this equipment in a residential area may cause harmful interference, in which case the user will be responsible for correcting any interference.

End User License agreement (EULA)

You have acquired a device that includes software licensed by Barco from Microsoft Licensing Inc. or its affiliates ("MS"). Those installed software products of MS origin, as well as associated media, printed materials, and "online" or electronic documentation ("SOFTWARE") are protected by international intellectual property laws and treaties. The SOFTWARE is licensed, not sold. All rights reserved.

IF YOU DO NOT AGREE TO THIS END USER LICENSE AGREEMENT ("EULA"), DO NOT USE THE DEVICE OR COPY THE SOFTWARE. INSTEAD, PROMPTLY CONTACT BARCO FOR INSTRUCTIONS ON RETURN OF THE UNUSED DEVICE(S) FOR A REFUND. ANY USE OF THE SOFTWARE, INCLUDING BUT NOT LIMITED TO USE ON THE DEVICE, WILL CONSTITUTE YOUR AGREEMENT TO THIS EULA (OR RATIFICATION OF ANY PREVIOUS CONSENT).

This EULA grants you the following license:

- You may use the SOFTWARE only on the DEVICE
- **NOT FAULT TOLERANT:** THE SOFTWARE IS NOT FAULT TOLERANT. BARCO HAS INDEPENDENTLY DETERMINED HOW TO USE THE SOFTWARE IN THE DEVICE, AND MS HAS RELIED UPON BARCO TO CONDUCT SUFFICIENT TESTING TO DETERMINE THAT THE SOFTWARE IS SUITABLE FOR SUCH USE
- **NO WARRANTIES FOR THE SOFTWARE:** THE SOFTWARE is provided "AS IS" and with all faults. THE ENTIRE RISK AS TO SATISFACTORY QUALITY, PERFORMANCE, ACCURACY, AND EFFORT (INCLUDING LACK OF NEGLIGENCE) IS WITH YOU. ALSO, THERE IS NO WARRANTY AGAINST INTERFERENCE WITH YOUR ENJOYMENT OF THE SOFTWARE OR AGAINST INFRINGEMENT. IF YOU HAVE RECEIVED ANY WARRANTIES REGARDING THE DEVICE OR THE SOFTWARE, THOSE WARRANTIES DO NOT ORIGINATE FROM, AND ARE NOT BINDING ON, MS.
- **No Liability for Certain Damages:** EXCEPT AS PROHIBITED BY LAW, MS AND BARCO SHALL HAVE NO LIABILITY FOR ANY INDIRECT, SPECIAL, CONSEQUENTIAL OR INCIDENTAL DAMAGES ARISING FROM OR IN CONNECTION WITH THE USE OR PERFORMANCE OF THE SOFTWARE. THIS LIMITATION SHALL APPLY EVEN IF ANY REMEDY FAILS OF ITS ESSENTIAL PURPOSE. IN NO EVENT MS AND BARCO SHALL BE LIABLE FOR ANY AMOUNT IN EXCESS OF U.S. TWO HUNDRED FIFTY DOLLARS (U.S.\$250.00).
- **Limitations on Reverse Engineering, Decompilation, and Disassembly:** You may not reverse engineer, decompile, or disassemble the SOFTWARE, except and only to the extent that such activity is expressly permitted by applicable law notwithstanding this limitation.
- **SOFTWARE TRANSFER ALLOWED BUT WITH RESTRICTIONS:** You may permanently transfer rights under this EULA only as part of a permanent sale or transfer of the Device, and only if the recipient agrees to this EULA. If the SOFTWARE is an upgrade, any transfer must also include all prior versions of the SOFTWARE.
- **EXPORT RESTRICTIONS:** You acknowledge that SOFTWARE is of US-origin. You agree to comply with all applicable international and national laws that apply to the SOFTWARE, including the U.S. Export Administration Regulations, as well as end-user, end-use and country destination restrictions issued by U.S. and other governments. For additional information on exporting the SOFTWARE, see <http://www.microsoft.com/exporting/>.
- **Installation and Use:** The SOFTWARE may not be used by more than two (2) processors at any one time on the DEVICE. You may permit a maximum of ten (10) computers or other electronic devices (each a "Client") to connect to the DEVICE to utilize the services of the SOFTWARE solely for file and print services, internet information services, and remote access (including connection sharing and telephony services). The ten (10) connection maximum includes any indirect connections made through "multiplexing" or other software or hardware which pools or aggregates connections. Except as otherwise permitted in the NetMeeting/Remote Assistance/Remote Desktop Features terms below, you may not use a Client to use, access, display or run the SOFTWARE, the SOFTWARE's user interface or other executable software residing on the DEVICE.
- If you use the DEVICE to access or utilize the services or functionality of Microsoft Windows Server products (such as Microsoft Windows NT Server 4.0 (all editions) or Microsoft Windows 2000 Server (all editions)), or use the DEVICE to permit workstation or computing devices to access or utilize the services or functionality of Microsoft Windows Server products, you may be required to obtain a Client Access License for the Device and/or each such workstation or computing device. Please refer to the end user license agreement for your Microsoft Windows Server product for additional information.
- **Restricted Uses:** The SOFTWARE is not designed or intended for use or resale in hazardous environments requiring fail-safe performance, such as in the operation of nuclear facilities, aircraft navigation or communication systems, air traffic control, or other devices or systems in which a malfunction of the SOFTWARE would result in foreseeable risk of injury or death to the operator of the device or system, or to others.

- **Restricted Functionality:** You are licensed to use the SOFTWARE to provide only the limited functionality (specific tasks or processes) for which the DEVICE has been designed and marketed by BARCO. This license specifically prohibits any other use of the software programs or functions, or inclusion of additional software programs or functions, on the DEVICE.
- **Security Updates:** Content providers are using the digital rights management technology ("Microsoft DRM") contained in this SOFTWARE to protect the integrity of their content ("Secure Content") so that their intellectual property, including copyright, in such content is not misappropriated. Owners of such Secure Content ("Secure Content Owners") may, from time to time, request MS, Microsoft Corporation or their subsidiaries to provide security related updates to the Microsoft DRM components of the SOFTWARE ("Security Updates") that may affect your ability to copy, display and/or play Secure Content through Microsoft software or third party applications that utilize Microsoft DRM. You therefore agree that, if you elect to download a license from the Internet which enables your use of Secure Content, MS, Microsoft Corporation or their subsidiaries may, in conjunction with such license, also download onto your DEVICE such Security Updates that a Secure Content Owner has requested that MS, Microsoft Corporation or their subsidiaries distribute. MS, Microsoft Corporation or their subsidiaries will not retrieve any personally identifiable information, or any other information, from your DEVICE by downloading such Security Updates
- **NetMeeting/Remote Assistance/Remote Desktop Features:** The SOFTWARE may contain NetMeeting, Remote Assistance, and Remote Desktop technologies that enable the SOFTWARE or other applications installed on the Device to be used remotely between two or more computing devices, even if the SOFTWARE or application is installed on only one Device. You may use NetMeeting, Remote Assistance, and Remote Desktop with all Microsoft products; provided however, use of these technologies with certain Microsoft products may require an additional license. For both Microsoft products and non-Microsoft products, you should consult the license agreement accompanying the applicable product or contact the applicable licensor to determine whether use of NetMeeting, Remote Assistance, or Remote Desktop is permitted without an additional license
- **Consent to Use of Data:** You agree that MS, Microsoft Corporation and their affiliates may collect and use technical information gathered in any manner as part of product support services related to the SOFTWARE. MS, Microsoft Corporation and their affiliates may use this information solely to improve their products or to provide customized services or technologies to you. MS, Microsoft Corporation and their affiliates may disclose this information to others, but not in a form that personally identifies you
- **Internet Gaming/Update Features:** If the SOFTWARE provides, and you choose to utilize, the Internet gaming or update features within the SOFTWARE, it is necessary to use certain computer system, hardware, and software information to implement the features. By using these features, you explicitly authorize MS, Microsoft Corporation and/or their designated agent to use this information solely to improve their products or to provide customized services or technologies to you. MS or Microsoft Corporation may disclose this information to others, but not in a form that personally identifies you.
- **Internet-Based Services Components:** The SOFTWARE may contain components that enable and facilitate the use of certain Internet-based services. You acknowledge and agree that MS, Microsoft Corporation or their affiliates may automatically check the version of the SOFTWARE and/or its components that you are utilizing and may provide upgrades or supplements to the SOFTWARE that may be automatically downloaded to your Device.
- **Links to Third Party Sites:** The SOFTWARE may provide you with the ability to link to third party sites through the use of the SOFTWARE. The third party sites are not under the control of MS, Microsoft Corporation or their affiliates. Neither MS nor Microsoft Corporation nor their affiliates are responsible for (i) the contents of any third party sites, any links contained in third party sites, or any changes or updates to third party sites, or (ii) webcasting or any other form of transmission received from any third party sites. If the SOFTWARE provides links to third party sites, those links are provided to you only as a convenience, and the inclusion of any link does not imply an endorsement of the third party site by MS, Microsoft Corporation or their affiliates.
- **Additional Software/Services:** The SOFTWARE may permit BARCO, MS, Microsoft Corporation or their affiliates to provide or make available to you SOFTWARE updates, supplements, add-on components, or Internet-based services components of the SOFTWARE after the date you obtain your initial copy of the SOFTWARE ("Supplemental Components"). If BARCO provides or makes available to you Supplemental Components and no other EULA terms are provided along with the Supplemental Components, then the terms of this EULA shall apply. If MS, Microsoft Corporation or their affiliates make available Supplemental Components, and no other EULA terms are provided, then the terms of this EULA shall apply, except that the MS, Microsoft Corporation or affiliate entity providing the Supplemental Component(s) shall be the licensor of the Supplemental Component(s). BARCO, MS, Microsoft Corporation and their affiliates reserve the right to discontinue any Internet-based services provided to you or made available to you through the use of the SOFTWARE. This EULA does not grant you any rights to use the Windows Media Format Software Development Kit ("WMFSDK") components contained in the SOFTWARE to develop a software application that uses Windows Media technology. If you wish to use the WMFSDK to develop such an application, visit <http://msdn.microsoft.com/workshop/imedia/windowsmedia/sdk/wmsdk.asp>, accept a separate license for the WMFSDK, download the appropriate WMFSDK, and install it on your system.
- **PATENT INFRINGEMENTS:** Barco disclaims any warranty that its Products do not infringe any patent, copyright or trademark; but agrees to indemnify you regarding such claims if you promptly notify BARCO in writing and if Barco shall have sole control of the defense of the action and its settlement or compromise. If the use of a Product is enjoined, or a settlement prevents continued use of the Product, Barco shall have the option to procure for you the right to continue use, or replace or modify the Product to remove the infringement. Barco shall have no liability or duty to indemnify you if the infringement or claim is based on use of the Product in combination with other products or software not furnished by Barco, where such claim would not have arisen if such Product were used independently. You will hold Barco harmless against any expense or loss resulting from any infringement caused by compliance with your designs, specifications, or instructions. The foregoing paragraph states Barco's entire liability with regard to infringement of patents, copyrights, or trademarks. This warranty on IP infringement only is valid within US, Canada, EC, Austria, Norway and Japan.

Trademarks

Brand and product names mentioned in this manual may be trademarks, registered trademarks or copyrights of their respective holders. All brand and product names mentioned in this manual serve as comments or examples and are not to be understood as advertising for the products or their manufactures.

TABLE OF CONTENTS

1. Packaging	5
1.1 Unpacking	5
2. Installation guidelines	7
2.1 Safety warnings.....	7
2.2 Installation guidelines	7
3. Installation	9
3.1 Connections	9
3.1.1 Power connection	9
3.2 Input source connections.....	9
3.2.1 Input section.....	9
3.2.2 Input facilities.....	9
3.2.3 5-Cable input	10
3.2.4 Composite Video Input.....	11
3.2.5 S-Video input.....	12
3.2.6 Digital Visual Interface (DVI) input	13
3.2.7 Computer input.....	13
3.2.8 Communications Connections.....	14
3.2.8.1 RS232 IN connection.....	14
4. Setup	15
4.1 RCU & Local keypad	15
4.2 Terminology overview	16
4.3 Switching on	18
4.4 Setting up the RCU address	19
4.5 Projector address.....	20
4.6 Orientation	21
4.7 Adjusting the lens.....	21
4.8 Preferences.....	23
4.8.1 Language.....	23
4.8.2 Quick access keys	24
4.8.3 Automatic startup	24
5. Getting started	27
5.1 Start up	27
5.2 Creating your personal PiP Layout	27
5.3 Adjusting the image	29
6. Advanced	31
6.1 Using the Dialog boxes.....	31
6.2 Source Selection	32
6.2.1 Source selection	32
6.2.2 Composite Video	33
6.2.3 S-Video	34
6.3 General menu	35
6.3.1 Pause.....	35
6.3.2 Freeze.....	36
6.3.3 Standby Timer.....	36
6.3.4 Audio (Optional).....	37
6.3.4.1 Audio Setup	37
6.3.4.2 Audio Settings	38
6.3.5 Identification.....	39
6.4 Image menu	40
6.4.1 Settings.....	40
6.4.1.1 Contrast.....	41
6.4.1.2 Brightness	41
6.4.1.3 Color	42
6.4.1.4 Tint (hue)	42
6.4.1.5 Sharpness	42
6.4.1.6 Gamma	43
6.4.1.7 Phase	43
6.4.1.8 Noise reduction	43
6.4.2 Aspect ratio	44
6.4.3 Show native resolution.....	46
6.4.4 Keystone	48
6.4.5 Color temperature.....	49
6.4.6 Filmmode detection (video only)	49
6.4.7 White peaking	51
6.4.8 Dynacolor™	52
6.4.9 Blanking	61
6.4.10 Input balance.....	61
6.4.11 AGC on Video.....	65

6.4.12	Manual Gain Control	66
6.5	Tools	67
6.5.1	Introduction to PiP	67
6.5.2	PiP select	69
6.5.3	PiP add window	69
6.5.4	PiP remove window	70
6.5.5	PiP layout	70
6.5.5.1	PiP Save	70
6.5.5.2	PiP rename layout	71
6.5.5.3	PiP delete layout	72
6.5.6	PiP Adjust	73
6.5.7	Color keying	73
6.5.8	Diagnostics	74
6.6	Signal Menu	74
6.6.1	Switching mode	74
6.6.2	Background	75
6.7	Lamp management	76
6.7.1	Runtimes	76
6.7.2	Mode	76
6.7.3	History	78
6.7.4	Reset runtime	79
6.7.5	Runtime warning	80
6.8	Image files menu	81
6.8.1	Load file	81
6.8.2	Auto Image	82
6.8.3	Edit file	84
6.8.4	Rename file	87
6.8.5	Copy	88
6.8.6	Delete	88
6.8.7	Forced file load	89
6.9	Display Setup	90
6.9.1	Full screen representation	90
6.9.2	Startup screen	91
6.9.3	Textbox	91
6.9.4	Take screenshot	91
6.9.5	Menu bar position	92
6.9.6	Status bar position	92
6.9.7	Sliderbox position	93
6.9.8	AutoImage Setup	93
6.9.9	Blanking	94
6.9.10	Soft Edge	95
6.9.10.1	Introduction	95
6.9.10.2	Soft Edge overlap zone (horizontal Soft Edge)	97
6.9.10.3	Soft Edge border adjustment	97
6.9.10.4	Black level of the images	100
6.10	Installation	101
6.10.1	Lens adjustments	101
6.10.2	Security	102
6.10.3	Change password	104
7.	iQ Network	107
7.1	Network architecture	107
7.2	Network functionality	108
7.3	iQ Pro Server specifications	109
7.4	Getting started	109
7.4.1	Connections	110
7.4.2	Installing the software	111
7.4.3	Start up of the BarcoReality SIM 5plus Server	111
7.4.4	Configuring the client software	113
7.4.5	Configuring the Server software	116
7.5	Control	121
7.5.1	Description	121
7.5.2	How to use the control manager?	122
7.5.3	General	122
7.5.4	The source selection screen	123
7.5.5	The PiP screen	123
7.5.6	Image settings	126
7.5.7	Advanced control	128
7.5.7.1	Lens adjustments	129
7.5.7.2	Options	129
7.6	Management & diagnostics	131
7.6.1	Description	131
7.6.2	Diagnostics manager	131
7.7	Configuration	132
7.7.1	E-mail messaging	132
7.7.2	E-mail configuration	132

7.7.3	Projector Firmware Upgrade	133
7.8	DropZone	135
7.8.1	Dropzone tools	135
7.8.2	Start up	135
7.8.3	File dropping/launching	137
7.8.4	Open remotely a file on the projector	139
7.8.5	Remote desktop sharing (virtual meeting)	139
7.8.6	DropZone settings	142
7.9	The Web client	143
8.	General guidelines on Network Configuration	145
8.1	General Network	145
8.2	The Internet and Web services	145
9.	Exchange	147
9.1	Exchange Installation	147
9.1.1	Installation procedure	147
9.1.2	Troubleshooting	148
9.2	Exchange Integration	149
9.2.1	Command	149
9.2.2	Example	151
9.2.3	Microsoft Outlook Integration	151
9.2.4	Folder form	153
9.2.5	Limitations and known "problems"	154
10.	SNMP services	155
10.1	SNMP installation	155
10.2	SNMP integration	155
11.	Standard Image Files	157
11.1	Table overview	157
12.	Troubleshoot	163
12.1	Using the OSD	163
12.2	FAQ table	164
13.	Maintenance	167
13.1	Cleaning the lens	167
13.2	Cleaning the dustfilters	167
13.2.1	Dustfilters	167
13.2.2	Cleaning	168
Index	171

1. PACKAGING

1.1 Unpacking



CEE7

European power plug to connect the power cord to the wall outlet.



ANSI 73.11

American power plug to connect the power cord to the wall outlet.

Content

- 1 projector (weight \pm 14 kg or 31 lbs)
- 1 remote control unit RCU + 2 batteries.
- 2 power cables with outlet plug type CEE7 and ANSI 73.11.
- 1 owners manual
- 1 safety manual
- 1 CDROM (containing manuals)

Form

The projector is packed in a carton box. To provide protection during transportation, the projector is surrounded with foam. The package is secured with banding and fastening clips.

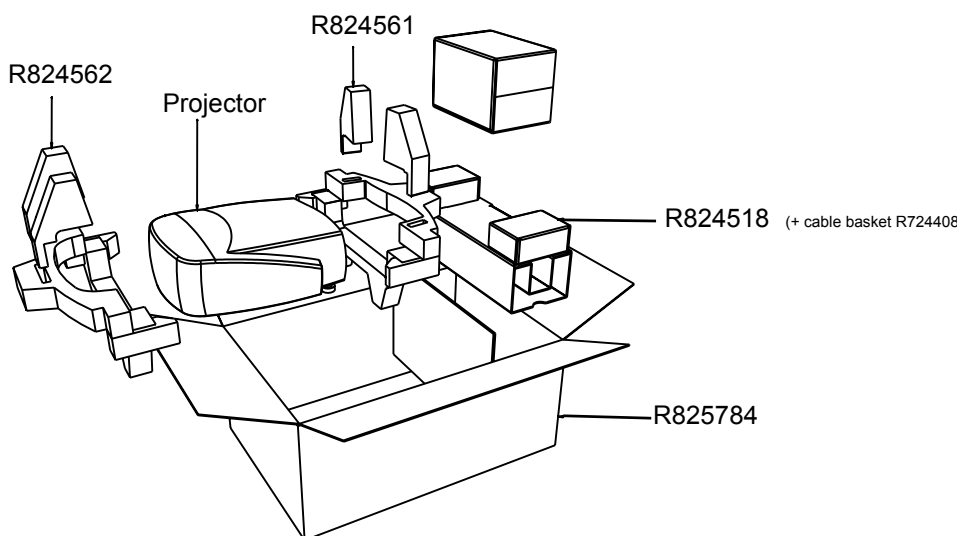

Image 1-1

Lens packaging

The Lens is supplied as an individual item.

The lens is packed in a carton box.



Save the original shipping carton and packing material, they will be necessary if you ever have to transport the lens.



CAUTION: Never transport the projector with the lens mounted on it !
Always remove the lens before transporting the projector.

1. Packaging

How to unpack the projector

1. Release the cord straps. (image 1-2)
2. Remove the assembly from the pallet
3. Remove the cardboard cover
4. Remove the large cardboard
5. Remove the 8 foam parts
6. Loosen and remove the 3 screws spacers fixing the projector to the wooden board
7. Remove the projector from the board

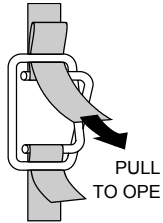

Image 1-2



Save the original shipping carton and packing material, they will be necessary if you ever have to ship your projector. For maximum protection, repack your projector as it was originally packed at the factory.

2. INSTALLATION GUIDELINES

2.1 Safety warnings



WARNING: Before installing the projector, read first the safety instructions in the safety manual (R5975258) delivered with the projector.

Insure that the projector is installed in an easy to evacuate room in case of a lamp explosion.

Mercury Vapor Warnings

Keep the following warnings in mind when using the projector. The lamp used in the projector contains mercury. In case of a lamp rupture, explosion there will be a mercury vapor emission. In order to minimize the potential risk of inhaling mercury vapors:

- Ensure the projector is installed only in ventilated rooms.
- Replace the lamp module before the end of its operational life.
- Promptly ventilate the room after a lamp rupture, explosion has occurred, evacuate the room (particularly in case of a pregnant woman).
- Seek medical attention if unusual health conditions occur after a lamp rupture, explosion, such as headache, fatigue, shortness of breath, chest-tightening coughing or nausea.

2.2 Installation guidelines

Ambient temperature check

Careful consideration of things such as image size, ambient light level, projector placement and type of screen to use are critical to the optimum use of the projection system.

Max. ambient temperature : 40 °C or 104 °F

Min. ambient temperature : 0 °C or 32 °F

The projector will not operate if ambient air temperature falls outside this range (0°C- 40°C or 32°F-104°F).

Environment

Do not install the projection system in a site near heat sources such as radiators or air ducts, or in a place subject to direct sunlight, excessive dust or humidity. Be aware that room heat rises to the ceiling; check that temperature near the installation site is not excessive



CAUTION: Harmful Environmental Contamination Precaution

Environment condition check

A projector must always be mounted in a manner which ensures the free flow of clean air into the projectors ventilation inlets as well as free flow at the ventilation outlets. The installation must also allow easy access to the consumable parts (dustfilters, lamps, ...) For installations in environments where the projector is subject to airborne contaminants such as that produced by smoke machines or similar (these deposit a thin layer of greasy residue upon the projectors internal optics and imaging electronic surfaces, degrading performance), then it is highly advisable and desirable to have this contamination removed prior to it reaching the projectors clean air supply. Devices or structures to extract or shield contaminated air well away from the projector are a prerequisite, if this is not a feasible solution then measures to relocate the projector to a clean air environment should be considered. Make sure that the projector never runs with dirty dustfilters as this will dramatically reduce the lifetime of the consumables. It is advised to clean the dustfilters on a regular basis and to replace them at any lamp change. Barco reserves itself the right to refuse warranty replacement of consumables if they have been used in a projector with dirty airfilters. Only use the manufactures recommended cleaning kit which has been specifically designed for cleaning optical parts, never use industrial strength cleaners on a projectors optics as these will degrade optical coatings and damage sensitive optoelectronics .

Failure to take suitable precautions to protect the projector from the effects of persistent and prolonged air contaminants will culminate in extensive and irreversible ingrained optical damage. At this stage cleaning of the internal optical units will be non-effective and impracticable. Damage of this nature is under no circumstances covered under the manufactures warranty and may deem the warranty null and void. In such a case the client shall be held solely responsible for all costs incurred during any repair. It is the clients responsibility to ensure at all times that the projector is protected from the harmful effects of hostile airborne particles in the environment of the projector. The manufacture reserves the right to refuse warranty repair if a projector has been subject to wantful neglect, abandon or improper use.

What about ambient light ?

The ambient light level of any room is made up of direct or indirect sunlight and the light fixtures in the room. The amount of ambient light will determine how bright the image will appear. So, avoid direct light on the screen. Windows that face the screen should be covered by opaque drapery while the set is being viewed. It is desirable to install the projection system in a room whose walls and floor are of non-reflecting material. The use of recessed ceiling lights and a method of dimming those lights to an acceptable level is also important. Too much ambient light will 'wash out' of the projected image. This appears as less contrast between the darkest and lightest parts of the image. With bigger screens, the 'wash out' becomes more important. As a general rule, darken the room to the point where there is just sufficient light to read or write comfortably. Spot lighting is desirable for illuminating small areas so that interference with the screen is minimal.

Which screen type ?

There are two major categories of screens used for projection equipment. Those used for front projected images and those for rear projection applications. Screens are rated by how much light they reflect (or transmit in the case of rear projection systems) given a determined amount of light projected toward them. The 'GAIN' of a screen is the term used. Front and rear screens are both rated in terms of gain. The gain of screens range from a white matte screen with a gain of 1 (x1) to a brushed aluminized screen with a gain of 10 (x10) or more. The choice between higher and lower gain screens is largely a matter of personal preference and another consideration called the Viewing angle. In considering the type of screen to choose, determine where the viewers will be located and go for the highest gain screen possible. A high gain screen will provide a brighter picture but reduce the viewing angle. For more information about screens, contact your local screen supplier.

Image size

The projector is designed for projecting an image size with a screenwidth from 1.00m (3.3ft) to 6.00m (19.7ft) with an aspect ratio of 4 to 3.

3. INSTALLATION

Overview

- Connections
- Input source connections

3.1 Connections

3.1.1 Power connection

AC power (mains) cord connection

Use the supplied power cord to connect your projector to the wall outlet.

Plug the female power connector into the male connector at the front of the projector.



The power input is auto-ranging from 90 to 240 VAC.

Fuses

For continued protection against fire hazard :

- refer replacement to qualified service personnel
- ask to replace with the same type of fuse.

3.2 Input source connections

3.2.1 Input section

Input Layers

The input section is divided in layers, each of them regrouping several inputs, this architecture allows the input section to be upgraded at any time with an optional analog or digital layer.

1. Layer 1: analog layer containing analog data and video inputs
2. Layer 2: a hybrid layer containing 2 digital and 1 analog input
3. Layer 3 : is an optional layer, it may be an Audio & Video analog layer or a SDI digital layer.



The optional layer is not available for the Pro version

3.2.2 Input facilities

overview

- 5-cable input
- composite video
- component video (PR/Y/PB)
- S-Video
- Digital Visual Input (DVI)
- Computer input

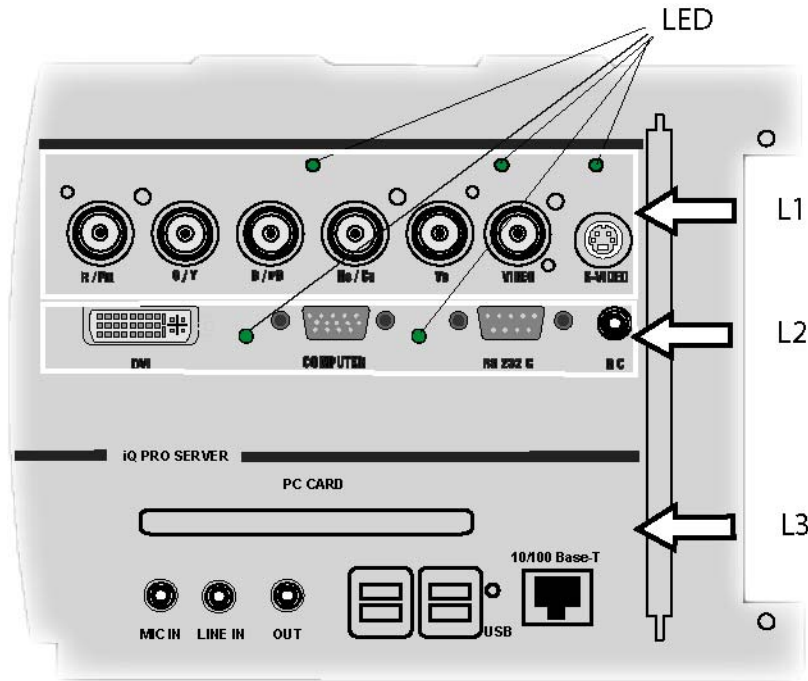

Image 3-1



A cable cover is supplied with the projector and can be fitted on the front of the projector

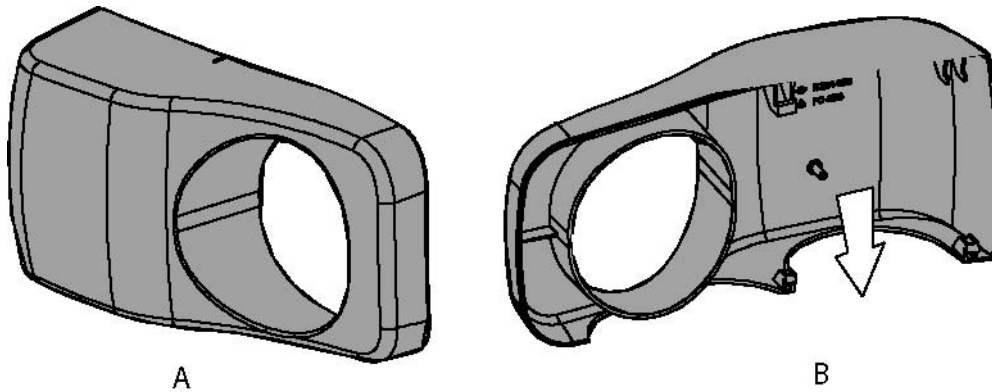

Image 3-2
Cable basket : the white arrow shows the cables leaving the projector

- A Front view
- B Back view

3.2.3 5-Cable input

Input specifications

The 5-cable input section is made of 5 BNC input terminals.

0.7 Vpp ± 3dB

75 Ω terminated

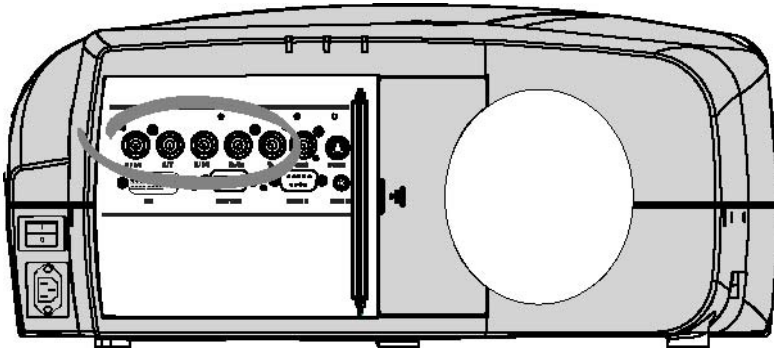

Image 3-3



Component Video

In Component Video the term component describes a number of elements that are needed to make up the video picture, these components are PR/Y/PB. A composite video signal on the other hand contains all the information needed for the color picture in a single channel of information

Which signals can be connected ?

Signals/Input BNC	R	G	B	H	V
RGBHV	R	G	B	H	V
RG _s B ¹	R	G _s	B	-	-
RGBS ¹	R	G	B	S	-
Component	PR	Y	PB	-	-

How to select a source on the 5 cable input ?

1. Press 1 on the RCU

Note: Another way for selecting this input is via **Source** on the local keypad or via the Menu

3.2.4 Composite Video Input

Input specifications

The Composite video input section is made of 1BNC input terminal.

1.0 V_{pp} ± 3dB

75 Ω terminated

No loop through

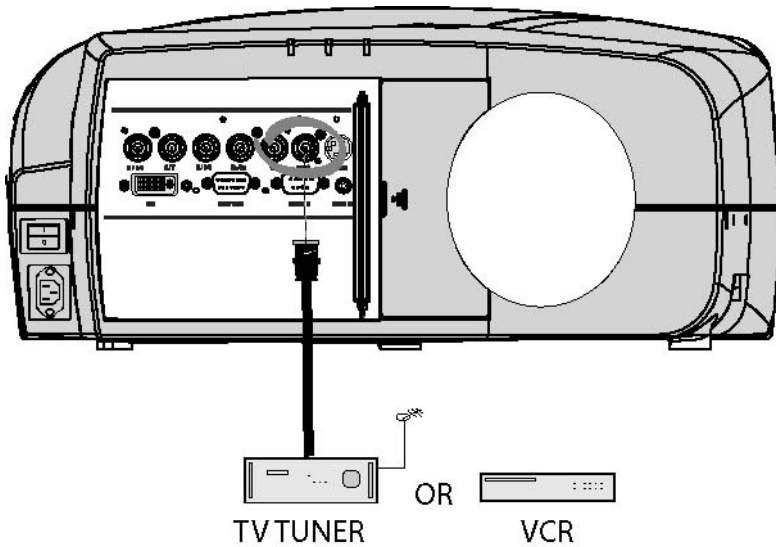

Image 3-4

How to select a Composite Video Input ?

1. Press **3** on the RCU

Note: Another way for selecting this input is via **Source** on the local keypad or via the Menu.

3.2.5 S-Video input

Input specification

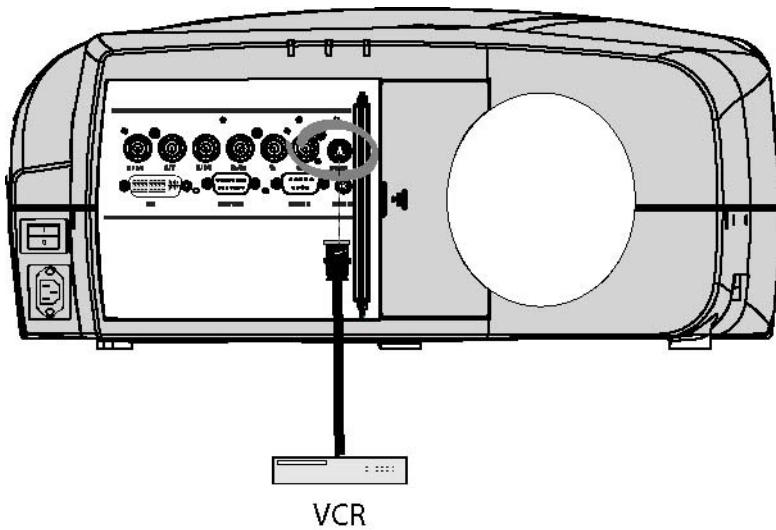

Image 3-5

Which signal can be connected ?

Standard S-Video (S-VHS) with separate Y(luma) and C (chroma) signals.

How to select the S-Video input ?

1. Press **4** on the RCU

Note: Another way for selecting this input is via **Source** on the local keypad or via the Menu.

3.2.6 Digital Visual Interface (DVI) input



DVI

Digital Visual Interface is a display interface developed in response to the proliferation of digital flat panel displays.

The digital video connectivity standard that was developed by DDWG (Digital Display Work Group). This connection standard offers two different connectors: one with 24 pins that handles digital video signals only, and one with 29 pins that handles both digital and analog video. This standard uses TMDS (Transition Minimized Differential Signal) from Silicon Image and DDC (Display Data Channel) from VESA (Video Electronics Standards Association).

DVI can be single or dual link.

Input specifications

Single link DVI

Differential input voltage: 200 mV - 800mV

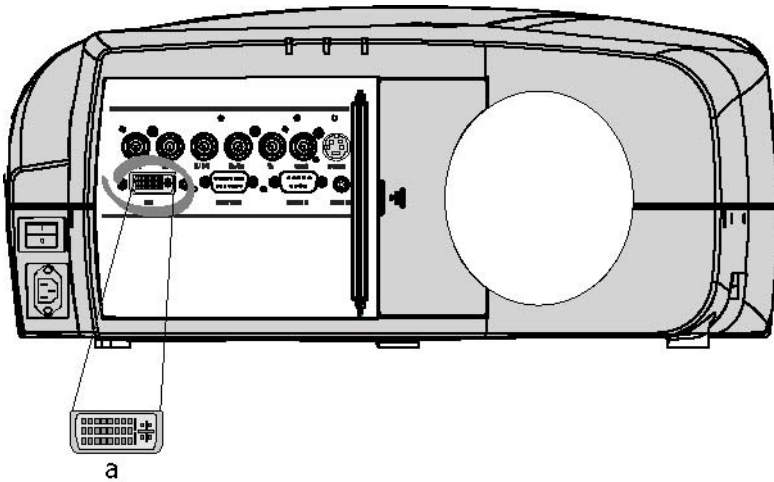

Image 3-6

a DVI-I type connector, analog link (4 pins at the right side of the connector) not supported

How to select the DVI Input ?

1. Press **5** on the RCU

Note: Another way for selecting this input is via the Menu.

3.2.7 Computer input

Input specification

TTL sync input : $U_{\min} = 2.0 \text{ V}$

RGB input = $0.7 \text{ V}_{pp} \pm 3\text{dB}$

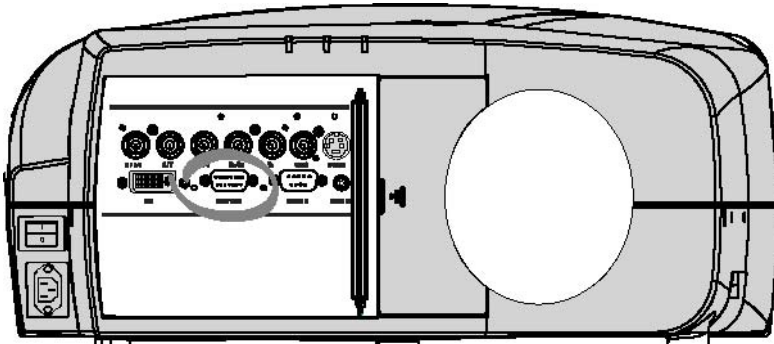

Image 3-7

What can be connected ?

- RGBHV
- RG_SB



Composite sync only possible on Green

How to select a computer input ?

1. Press **2** on the RCU

Note: Another way for selecting this input is via the Menu.

3.2.8 Communications Connections

Overview

- RS232 IN connection

3.2.8.1 RS232 IN connection

What can be connected to the RS232 IN connection ?

The RS 232 IN connections allows the projector to communicate with a Computer e.g. IBM PC or Apple Macintosh.

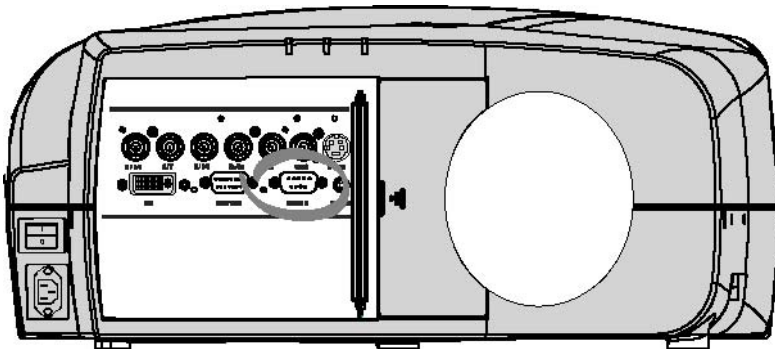

Image 3-8

Applications of the RS232 connection

Remote control:

- easy adjustment of projector via IBM PC (or compatible) or MAC connection.
- address range from 1 to 255
- allow storage of multiple projector configurations and set ups.
- wide range of control possibilities

Data communication: sending data to the projector or copying the data from the projector to the computer



To set up the baudrate of the projector, see the Installation menu

4. SETUP

Overview

- RCU & Local keypad
- Terminology overview
- Switching on
- Setting up the RCU address
- Projector address
- Orientation
- Adjusting the lens
- Preferences

4.1 RCU & Local keypad

How controlling the projector ?

The projector can be controlled by the local keypad or by the remote control unit.

Location of the local keypad ?

The local keypad is located on the topside of the projector.

For key overview: "Terminology overview", page 16

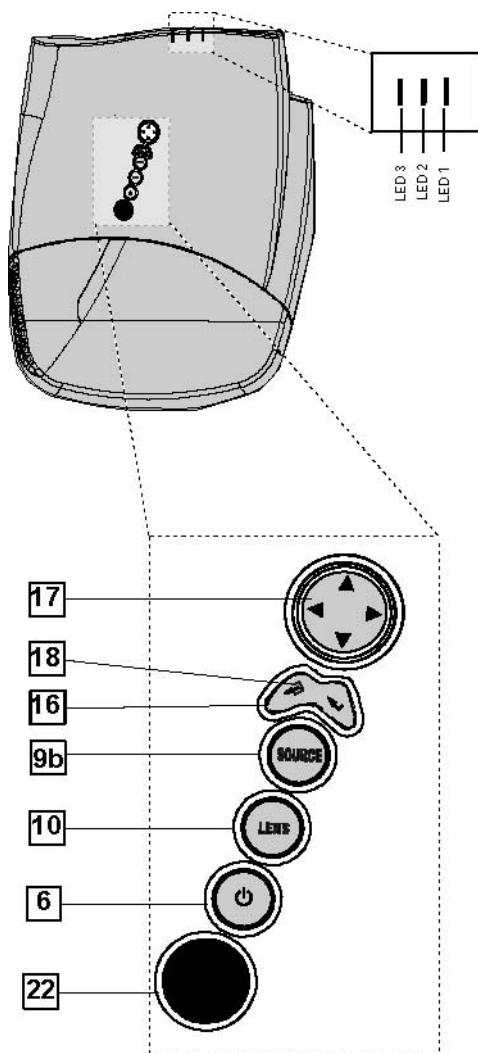

Image 4-1
Local keypad layout

4. Setup

Remote control functions.

This remote control includes a battery powered infrared (IR) transmitter that allows the user to control the projector remotely. This remote control is used for source selection, control, adaptation and set up. It includes automatic storing of picture controls (Brightness, Sharpness...) and settings.

Other functions of the remote control are :

- switching between stand by and operational mode.
- switching to "pause" (blanked picture, full power for immediate restarting)
- direct access to all connected sources.

Diagnose LED's

	Green	Red
LED1	cool down sequence: flickers 60 seconds (120 seconds in case of iQ 400 series) after switching to standby	rescue program (software error)
LED2	only for the versions containing a server: shows when projector is in standby and server is active.	hardware error
LED3	IR acknowledgement	continue : standby flickers : Security = ON

4.2 Terminology overview

Overview

The following table gives an overview of the keys.

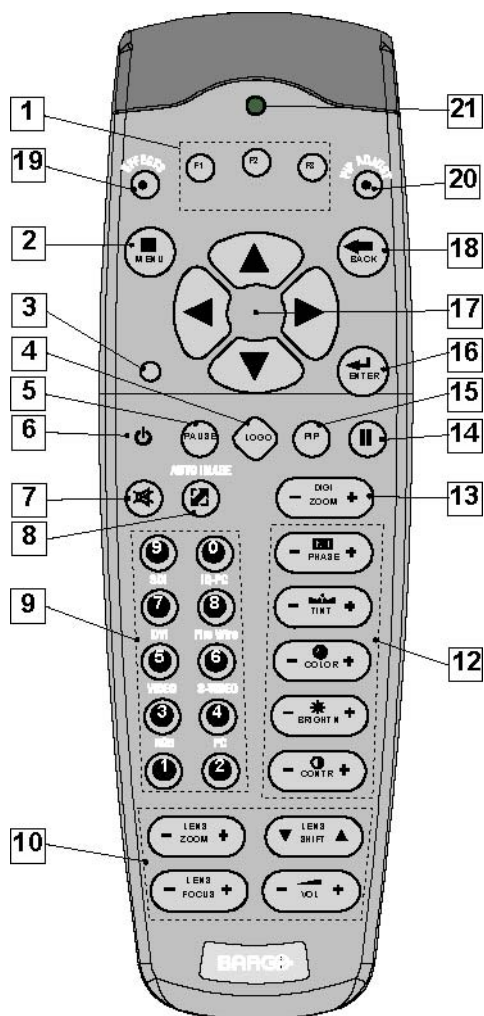

Image 4-2

1	Function keys	user programmable keys with functions for direct access.
2	MENU	Menu key, to enter or exit the Toolbar menu.
3	Address key	(recessed key), to enter the address of the projector (between 0 and 9). Press the recessed address key with a pencil, followed by pressing one digit button between 0 and 9.
4	LOGO key	allows to recall the stored Logo (not in PiP mode)
5	PAUSE	to stop projection for a short time, press 'PAUSE'. The image disappears but full power is retained for immediate restarting.
6	STBY	standby button, to start projector when the power switch is switched on and to switch off the projector without switching off the power switch. Attention : Switching to Standby. When the projector is running and you want to go to standby, press the standby key for 2 seconds.
7	MUTE	to interrupt the sound reproduction (audio = optional).
8	AUTOIMAGE	Auto image, to center the image on the active LCD surface.
9	Digit buttons	direct input selection.
9b	SOURCE button	this button allows to switch through the active (scanned) inputs
10	Lens control	use these buttons to obtain the desired ZOOM, SHIFT, FOCUS.
11	VOL	use this button to obtain the desired sound level (audio = optional)
12	Picture controls	use these buttons to obtain the desired picture analog level.

4. Setup

13	DIGI ZOOM	allows a digital Zoom of a part of the image
14	FREEZ	press to freeze the projected image.
15	PIP	allows to activate the PICTURE IN PICTURE mode
16	ENTER	to confirm an adjustment or selection in the MENU. On the local keypad the ENTER button additionally accesses the PIP window resize function
17	Cursor keys	Cursor Keys on RCU or on the local keypad : to make menu selections or to access the toolbar.
18	BACK	to leave the selected menu or item (go upwards to previous menu).
19	EFFECTS	not yet implemented
20	PIP ADJUST	allows to select a PiP window and change its configuration on screen
21	RC operating indication	lights up when a button on the remote control is pressed. (This is a visual indicator to check the operation of the remote control)
22	IR receiver	IR receiver

Table 4-2



ordernumber RCU: R763794K

4.3 Switching on

How to switch on.

1. Press the power switch to switch on the projector.
 - When '0' is pushed in, the projector is switched off.
 - When '1' is pushed in, the projector is switched on

The projector starts in standby mode, LED3 is red.

Starting image projection.

1. Press **Standby** key once on the local keypad or on the remote control. (image 4-3)

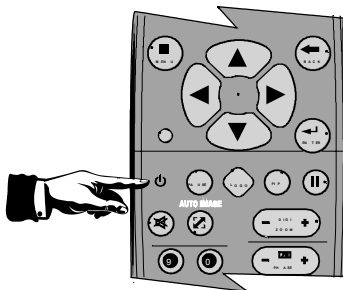

Image 4-3



It may take about 60 seconds before image projection, i.e. no projection until the completion of several operations (software initialization,...).



If the Security mode is enabled, a textbox will be displayed for PIN code entry, see *Security* setting in the *Installation* menu

4.4 Setting up the RCU address

What has to be done ?

To allow the communication between the RCU and the projector the RCU has to be programmed with the same address as the projector.

This address must be in the range 0–9.

To know the address of the projector, one can visualize it in projection mode (on screen) as well as in standby mode (shown with the LED's on top cover of the projector).



For more info on addresses see the appendix



At this stage the image projected may happen to be upside down or mirrored, this can be set in the *Installation* menu under *Projector orientation* (see further setting up the projector's orientation).

Displaying the Projector Address in Standby mode

1. Press the **Address** key (recessed key on the RCU) with a pencil. (image 4-4)

All the LED's (3) on the top cover of the projector go out.

Then LED1 starts blinking green the number of hundreds. After that LED2 starts blinking the number of tens. Finally LED3 starts blinking green the number of units. If this is done, the original status of the LED's is restored.

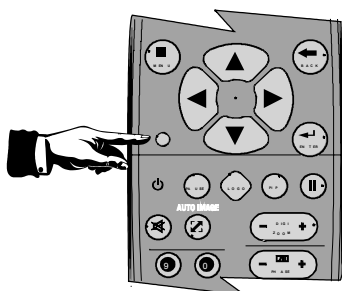

Image 4-4

Displaying the Projector Address in projection mode)

1. Press the **Address** key (recessed key on the RCU) with a pencil.

The projector's address will be displayed on the screen in a Textbox

Programming the RCU

1. Push the address key If the address is not entered within 5 seconds, the RCU returns to its default address (zero address) and controls then all projectors in the room.
2. Enter the same address with the digit buttons **within 5 seconds** after pushing the address key.

The projector can now be controlled with the RCU.



For example : if the projector address is 3, then press "3" on the RCU to set the RCU's address to match the projector's address.



Common address/Projector address : Beside the projector address, the projector disposes also of a Common address which can be set to "0" or "1" (by default "0").

In other words, an RCU set to address "0" will always control a projector regardless of its projector address (since it uses the common address).

4.5 Projector address

What can be done ?

The projector is shipped with projector address set to "0"

In some cases the projector address must be changed, for example if an unique RCU is used to control 2 or more projectors (independently).

In the OSD menu *Projector Address*, the following addresses can be programmed :

- Projector address: address defined by the user, may be from 0 to 255
0-9 is used for RCU communication, 0-255 being used for RS232 serial communication.
- Common address : address may be 0 or 1

How to change the projector's RC5 address ?

1. Press **MENU** to activate the Tool bar
2. Press → to select the *Installation*
3. Press ↓ to Pull down the *Installation* menu
4. Use ↑ or ↓ to select *Projector address* (image 4-5)
5. Press **ENTER**

A dialog box appears on the screen. (image 4-6, image 4-7)

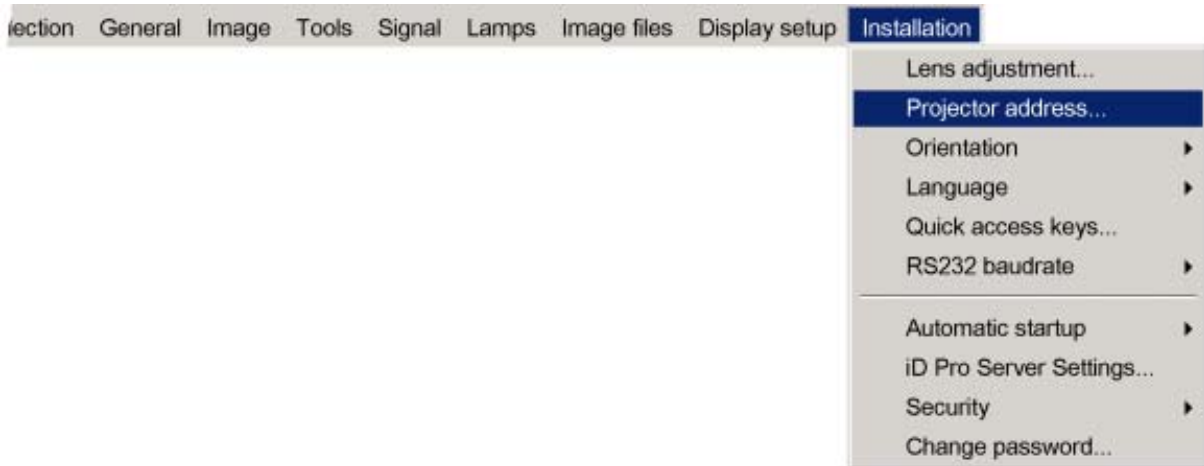

Image 4-5

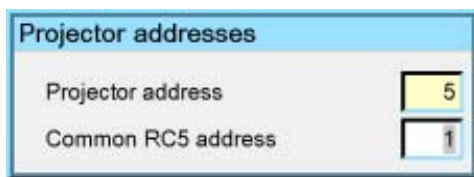

Image 4-6



Image 4-7

Entering the new projector address ?

1. Enter the new projector address with the digit keys on the RCU, the local keypad or the cursor keys.



This address must be between 0 and 255.

How to change the common RC5 address ?

1. Press **MENU** to activate the Tool bar
2. Press → to select the *Installation*
3. Press ↓ to Pull down the *Installation* menu
4. Use ↑ or ↓ to select *Projector address*

5. Press **ENTER**

A dialog box appears on the screen.

Entering the new common address ?

1. Enter the new projector address with the digit keys on the RCU, the local keypad or the cursor keys.



This address must be between 0 or 1.

4.6 Orientation

Projector orientations

Depending on how the projector is oriented, the projector's internal settings have to be adapted.

How to change the orientation ?

1. Press **MENU** to activate the Toolbar
2. Press → to select the *Installation* item
3. Press ↓ to Pull down the *Installation* menu
4. Use ↑ or ↓ to select *Orientation*
5. Press → to pull down the menu
6. Use ↓ or ↑ to select the desired orientation (image 4-8)
7. Press **ENTER**

The projection is adapted and a black bullet shows the active configuration.

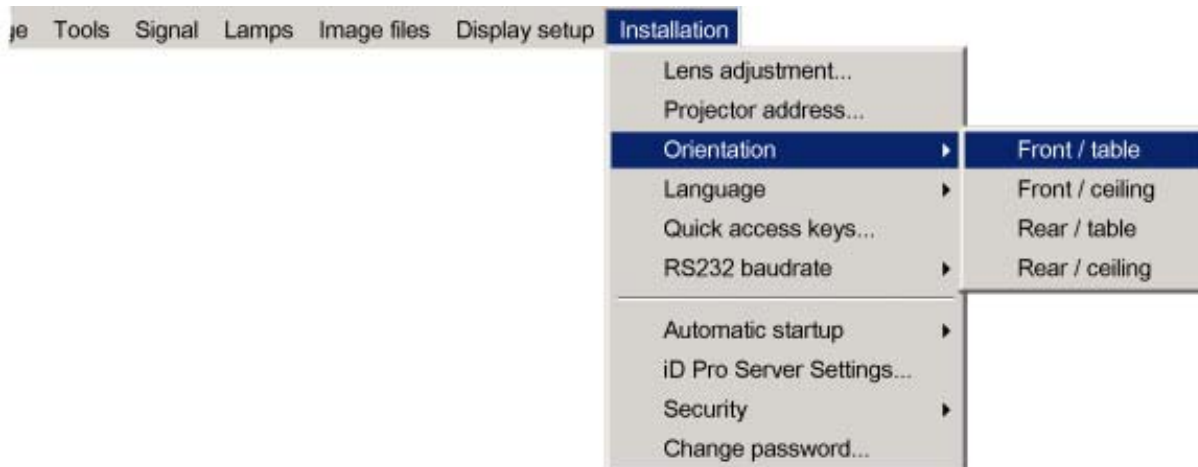

Image 4-8

4.7 Adjusting the lens

What must be done ?

Depending on the projection distance and the lens used, the image may not be at the desired size, position and/or may be out of focus.

The projector will always allow you to shift your image vertically as well as horizontally (when available) to position it on the screen. In addition, motorized lenses will also allow you to Zoom and focus the image.

All these lens parameters can be adjusted using the RCU, the local keypad or in the Installation menu of the projector's OSD.

- Zoom (only for motorized lenses)
- Focus (only for motorized lenses)
- Vertical Shift



The lens can also be adjusted via the dedicated keys on the remote.

How to Zoom/focus or shift via the RCU (or keypad)

1. Press **LENS ZOOM** or **LENS FOCUS** or **LENS SHIFT** on the RCU (image 4-9)
2. Use the arrow keys to adjust (image 4-10)

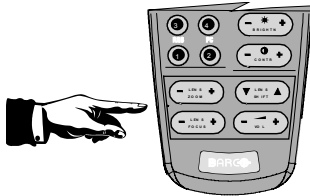

Image 4-9

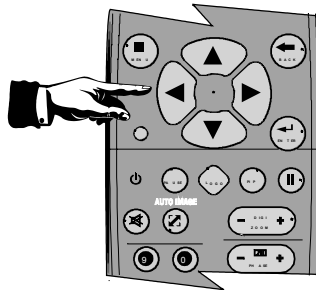

Image 4-10

How to Zoom/focus or shift in the OSD ?

1. Press **MENU** to activate the Tool bar
2. Press **→** to select the *Installation*
3. Press **↓** to Pull down the *Installation* menu
4. Use **↑** or **↓** to select *Lens adjustments...* (image 4-11)
5. Press **ENTER**

A textbox appears on the screen, follow the instructions. (image 4-12, image 4-13)

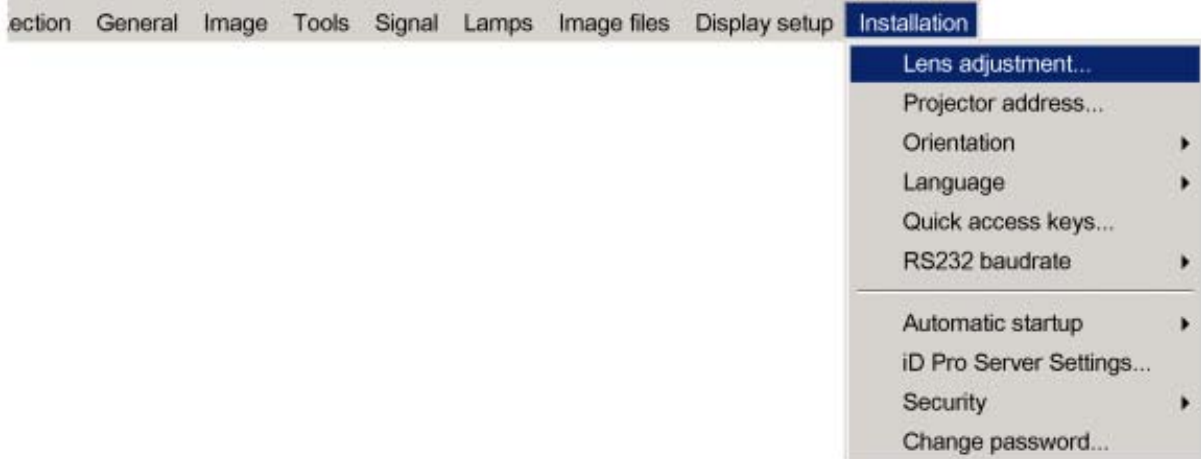

Image 4-11

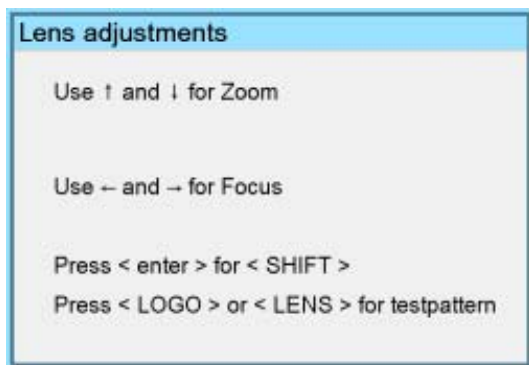

Image 4-12

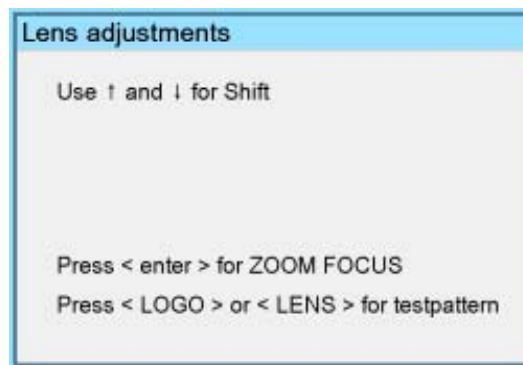

Image 4-13



The use of a sheet of paper held in front of the screen can be useful to determine the focus plane (position for best focus)



Vertical shift range : -120% to 120%

4.8 Preferences

4.8.1 Language

List of languages

The list of selectable languages is depending on the software of the projector.

How to change the Language ?

1. Press **MENU** to activate the Tool bar
2. Press → to select the *Installation* item
3. Press ↓ to Pull down the *Installation* menu
4. Use ↑ or ↓ to select *Language*
5. Press → to pull down the menu
6. Use ↓ or ↑ to select the desired language (image 4-14)
7. Press **ENTER**

The language is adapted and a black bullet shows the active configuration.

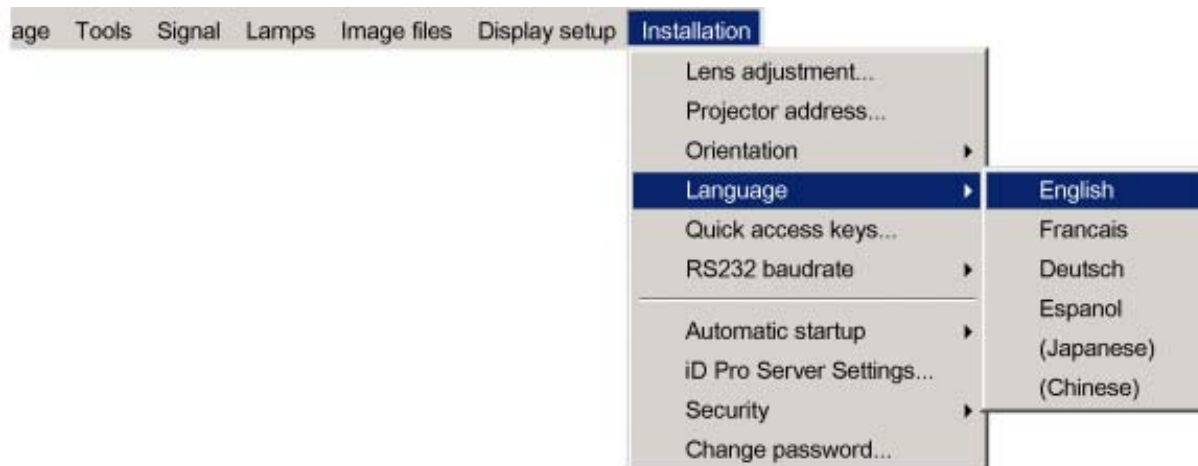

Image 4-14

4.8.2 Quick access keys

What can be done ?

The 3 function keys on top of the RCU can be associated with a particular item in one of the menus.

Each function which is not password protected or does not have a key on the RCU can be associated to a function key.

How to get an overview of the quick access keys ?

1. Press **MENU** to activate the Tool bar
2. Press **→** to select the *Installation*
3. Press **↓** to Pull down the *Installation* menu
4. Use **↑** or **↓** to select *Quick access keys* (image 4-15)
5. Press **ENTER**

A text box appears on the screen.

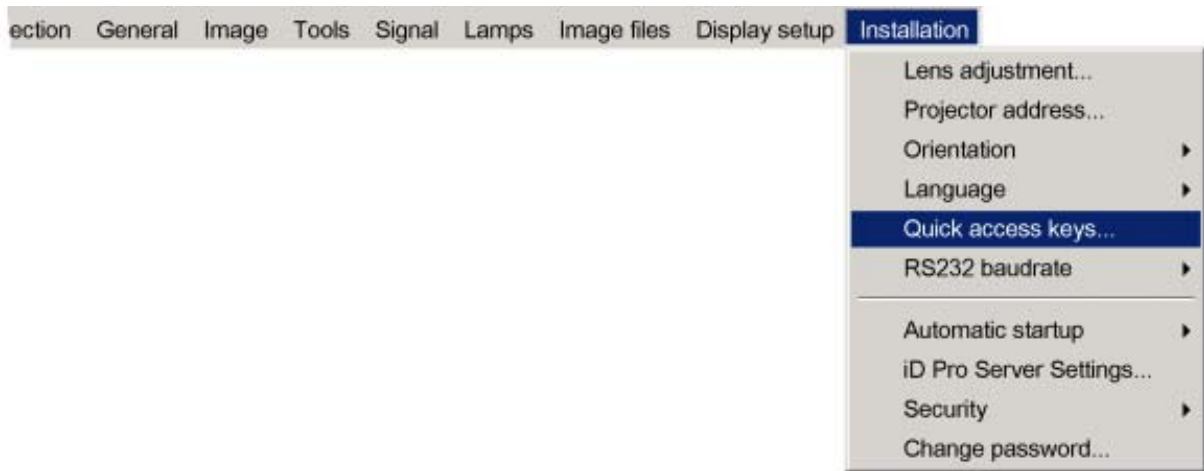

Image 4-15

How to program the quick access keys ?

1. Scroll through the menus to the desired menu item
2. Push the desired function key for 3 seconds (image 4-16)

The menu item is stored in the quick access key

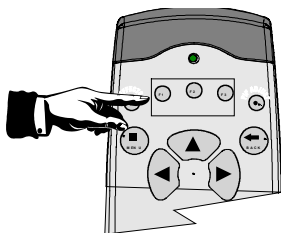

Image 4-16



Factory pre-programmed functions

- F1 : color depth
- F2 : noise reduction
- F3 : orientation

4.8.3 Automatic startup

What can be done ?

The automatic startup allows to bypass the standby state i.e. start up without going in standby state after switching on the projector.

This means that the automatic startup allows immediate restart of the projector after a power failure (breakdown), i.e. without passing through the standby state, by recovering the previous settings (previous source,...).

This function can be disabled if undesired or inadequate for safety reasons, etc.



CAUTION: If the Automatic startup function is enabled one must be aware of the fact that it involves safety precautions

Make sure that the projector (or the operators!) will not be affected by altered environmental conditions when restarting at power resume.

How to enable/disable the Automatic startup?

1. Press **MENU** to activate the Tool bar
2. Press → to select the *Installation* item
3. Press ↓ to Pull down the *Installation* menu
4. Use ↑ or ↓ to select *Automatic startup*
5. Press → to pull down the menu
6. Use ↓ or ↑ to enable/disable the automatic startup (image 4-17)
7. Press **ENTER**

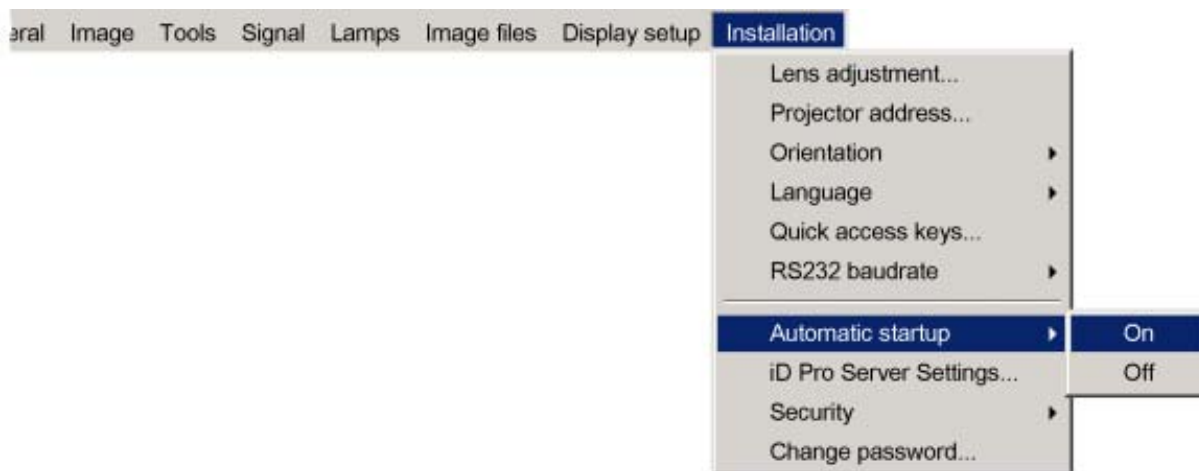

Image 4-17

5. GETTING STARTED

5.1 Start up

How to start up the projector ?

1. Press the Standby button on the RCU or the local keypad (image 5-1)

The last selected source is displayed

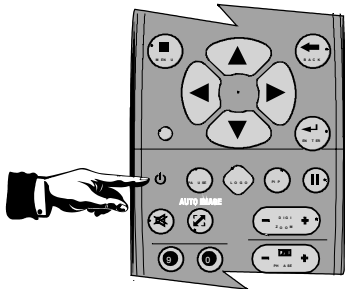

Image 5-1

5.2 Creating your personal PiP Layout



As an example: the layout to be created must contain :

- one video source : composite video
- one data source : RGBHV

How to create a new layout based on an existing layout ?

1. Select an existing custom layout (non factory) from the *PiP select* menu (image 5-2)
2. Add the video window from the *PiP add window* menu by selecting the desired composite video source (image 5-3, image 5-4)
Note: You can only use one (2 in case of an optional video input) video source i.e. if the layout already contains a video source, it will be impossible to add another (different) video input .
3. Follow the instruction wizard (size, position, order)
4. Repeat the previous steps to add the RGB source
5. Save the PiP layout in the *PiP layout/Save as* menu by typing a new name

See image 5-5.

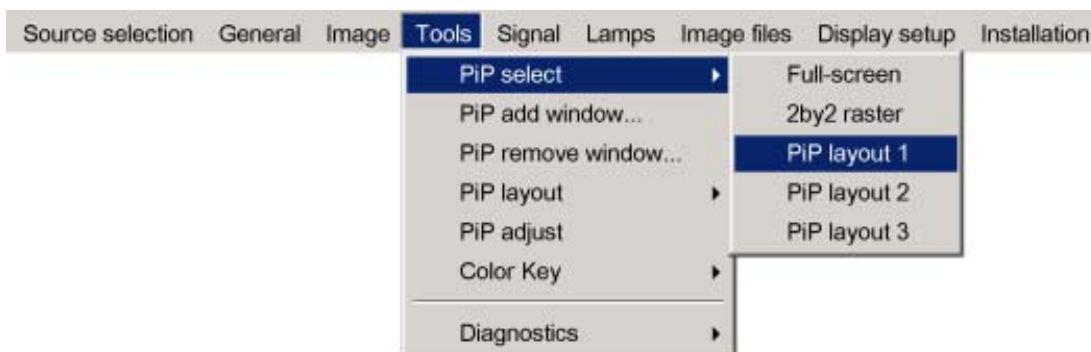

Image 5-2

5. Getting started



Image 5-3

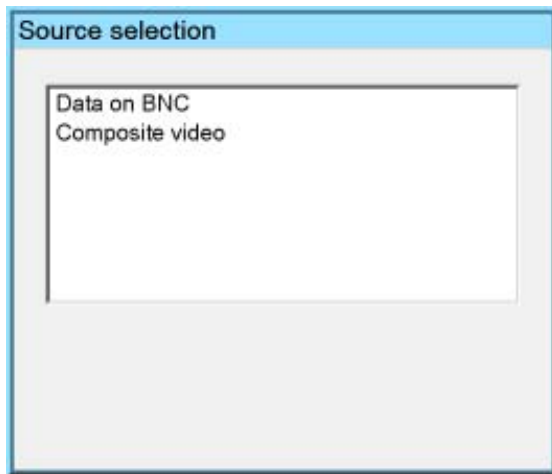

Image 5-4

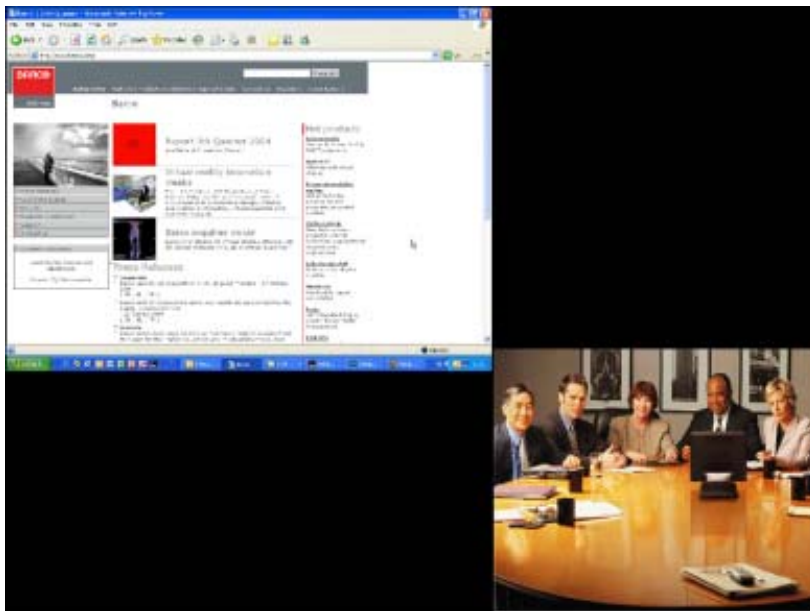

Image 5-5
Video/Data PIP layout



The added source(s) should be displayed with the right settings thanks to AutoImage. If it's not the case (in case of some non standard source specifications) see *Image files* in the Advanced chapter.

5.3 Adjusting the image

How to adjust the image

1. Use the PiP adjust button on the RCU to select the desired window (image 5-6)
2. Use the Image setting buttons on the RCU (image 5-7)

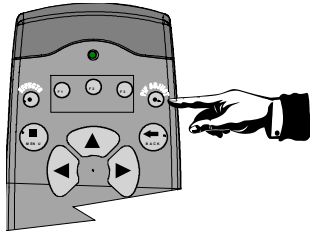

Image 5-6

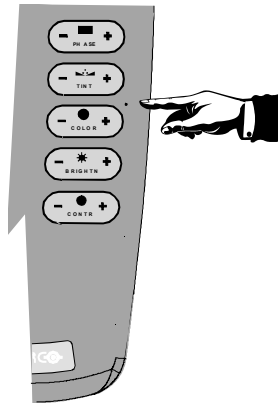

Image 5-7

6. ADVANCED

6.1 Using the Dialog boxes

How to use the dialog boxes ?

Some parameters are modified by means of a dialog box, where selections can be made and/or values can be entered.

The values can be entered in several ways:

Entering numeric values using the numeric keys on the remote control

1. Press **ENTER** to activate the input field. (image 6-1)
2. Key in the desired value.

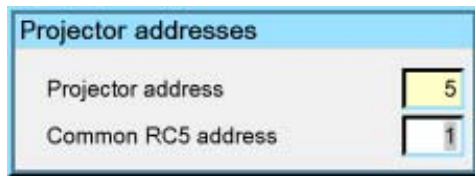

Image 6-1

Entering numeric values using the arrow keys on the remote control

1. Press **ENTER** to activate the input field.
2. Press ← or → to select the digit to be changed. (image 6-2)
3. Press ↓ or ↑ to increase or decrease the value.

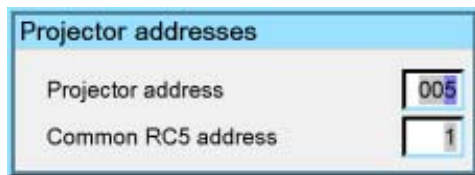

Image 6-2

Entering numeric values using the arrow keys on the local keypad

1. Press **ENTER** to activate the input field.
2. Press ← or → to select the digit to be changed.
3. Press ↓ or ↑ to increase or decrease the value.



To confirm the changes always press **ENTER**.

Use ↓ or ↑ to browse between the different fields.



In some cases an alphanumeric value (file name, ...) has to be entered. Use ↑ or ↓ to scroll through the character values once the input field is activated.

Following characters can be browsed in this particular order:

Decimal scroll list: 0123456789

Signed decimal scroll list: 0123456789-

ASCII scroll list: ABCDEFGHIJKLMNOPQRSTUVWXYZ0123456789+~*/&@#.,:;abcdefghijklmnopqrstuvwxy

6.2 Source Selection

Overview

- Source selection
- Composite Video
- S-Video

6.2.1 Source selection

Selecting a source

The Source selection menu allows to select one of the different sources. Another method to select an input source is via the remote control using the numeric keys or by using the local keypad.



When selecting a source with a different resolution (and/or aspect ratio) than the projector's resolution (and/or aspect ratio), the source can be shown in its native resolution or can be re-scaled to the projector's resolution, the latter case brings of course some loss of quality.

For more info on resolution match see the Show native resolution function in the *Image* menu.

How to select a source ?

1. Press **MENU** to activate the Tool bar
2. Press **↓** to Pull down the Source Selection menu (image 6-3, image 6-4)
3. Use **↑** or **↓** to select one of the different sources (Press **→** to Pull down if the item has a submenu)
4. Press **ENTER** to confirm your choice

On the screen appears now the selected source.

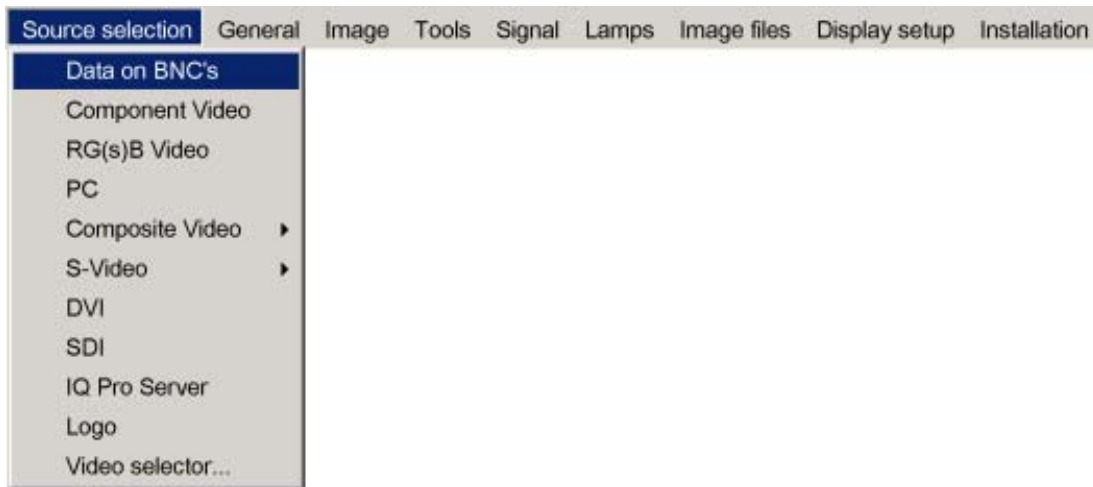

Image 6-3

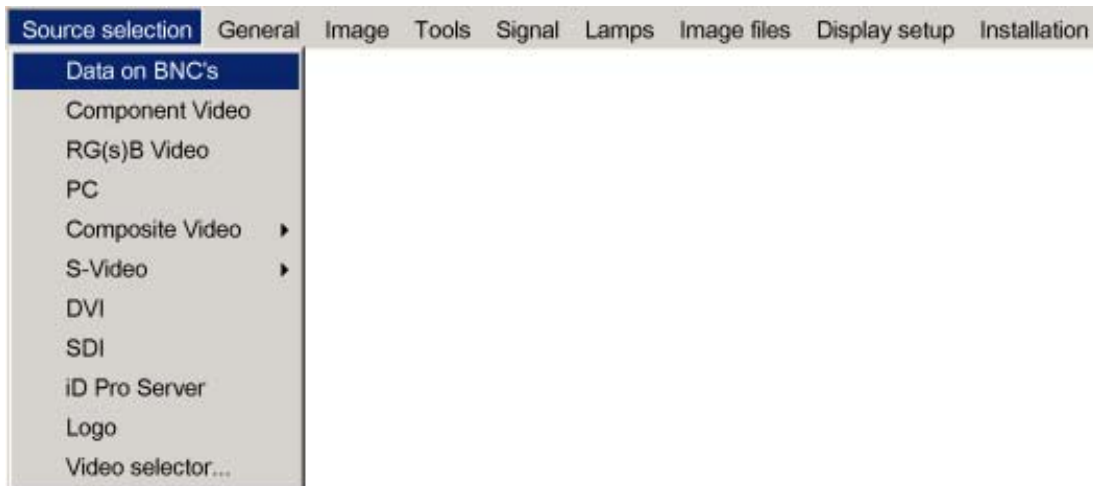

Image 6-4



The Barco logo on the menu indicates the presence of a signal, the digit indicates the shortcut key on the RCU.

The 3 first sources (Data on BNC's, Component Video & RG(s)B) refer to the 5-cable input, the position of the indication "1" will always show which BNC configuration is selected.

When to select "Data on BNC's"

Select Data on BNC's when a data signal is connected to the BNC's

When to select "Component video" ?

Select Component video when a video signal of the type (R-Y/Y/B-Y) is connected on the BNC's.

When to select RG_sB Video ?

Select RG_sB Video when an RGB video signal (15 KhZ) with Sync on green or sync on H is presented on the BNC's.

This signal is routed to the video circuit and is projected in a Video Window.

6.2.2 Composite Video

How to select one of the 7 composite video inputs ?

1. Press **MENU** to activate the Tool bar
2. Press ↓ to Pull down the Source Selection menu
3. Use ↑ or ↓ to select *Composite video*
4. Press → to Pull down the submenu
5. Use ↑ or ↓ to select one of the different video inputs (image 6-5)

Note: *Video2 is an optional Video input and is only displayed in case the optional Video/Audio layer is installed.*

If the extended mode is disabled, the submenu contains only 1 selection (2 selections if the Audio & Video option is installed).

6. Press **ENTER** to confirm your choice

A white bullet indicates the selected composite video source which now appears on the screen.

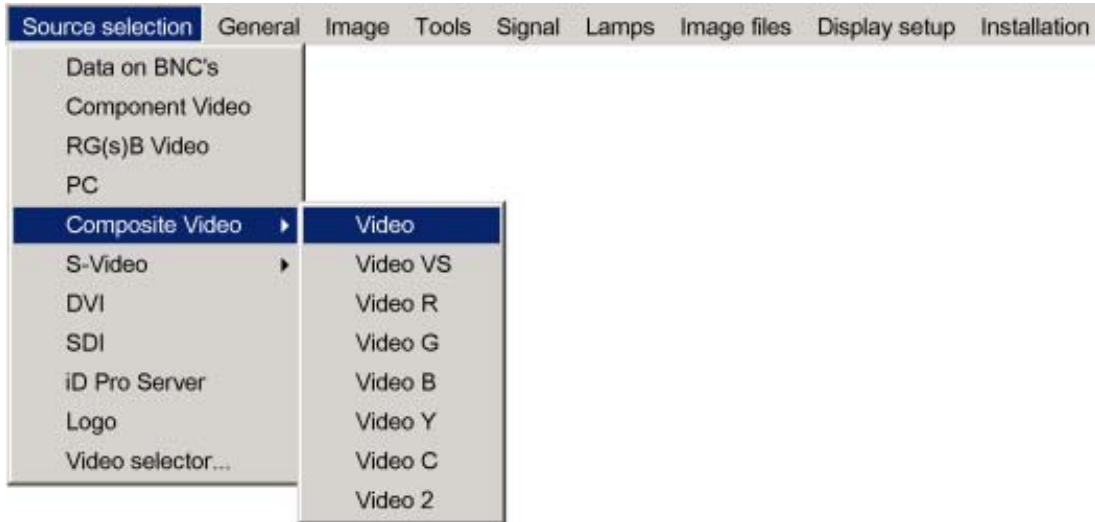

Image 6-5

Adjustments on a Composite video signal

The projectors allows different adjustments on a composite video signal. Depending on the type of signal (NTSC /PAL) the terminology may differ :

- Contrast
- Brightness
- Color : adjusts the level of color saturation in a PAL signal
- Tint : adjusts the level of color saturation in an NTSC signal
- AGC: Automatic Gain Control



The composite video sources can also be selected using the video selector or via the dedicated key 3 on the RCU. Key 3 allows to browse through the active video inputs when the extended mode is checked in Video Selector..

6.2.3 S-Video

When

Select the S-Video input when in presence of a video signal also called S-VHS signal.

An S-Video signal is available on the Mini-Din connector of a camera, VCR or DVD player.

How to select one of the 3 S-Video inputs ?

1. Press **MENU** to activate the Toolbar
2. Press ↓ to Pull down the Source Selection menu
3. Use ↑ or ↓ to select *S-Video*
4. Press → to Pull down the submenu
5. Use ↑ or ↓ to select one of the different video inputs (image 6-6)

Note: *S-Video4 is an optional Video input and is only displayed in case the optional Video/Audio layer is installed*

If the extended mode is disabled, the submenu contains only 1 selection (2 selections if the Audio & Video option is installed).

6. Press **ENTER** to confirm your choice

A white bullet indicates the selected video source which now appears on the screen.

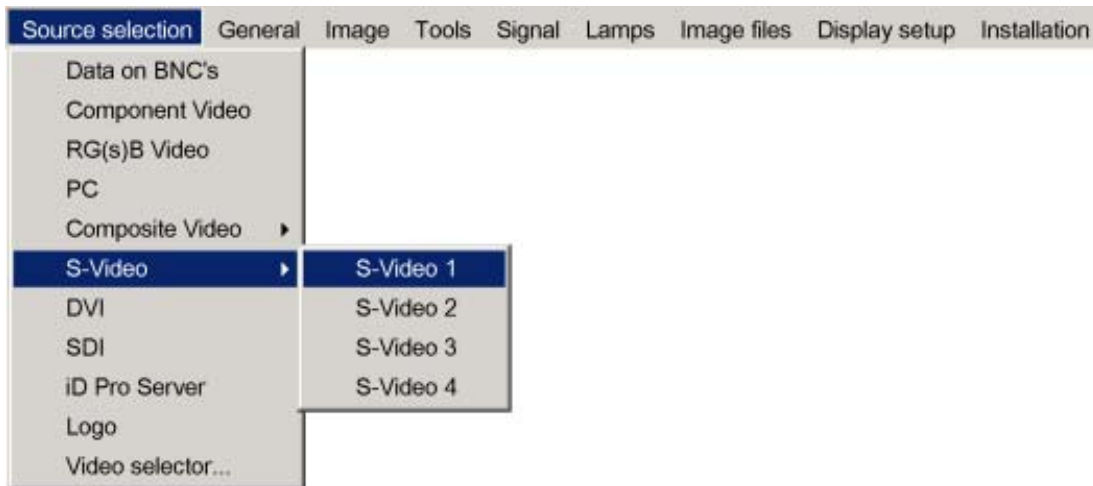

Image 6-6



The S-Video sources can also be selected using the video selector or via the dedicated key 4 on the RCU. Key 4 allows to browse through the active S-Video inputs when the extended mode is checked in Video Selector.

6.3 General menu

Overview

- Pause
- Freeze
- Standby Timer
- Audio (Optional)
- Identification

6.3.1 Pause

Interrupting the image projection

With the Pause function, the image projection can be stopped, the projector remains with full power for immediate restart.

How to interrupt the image projection ?

1. Press **MENU** to activate the Tool bar
2. Press → to select *General*
3. Press ↓ to Pull down the General menu
4. Use ↑ or ↓ to select *Pause* (image 6-7)
5. Press **ENTER** to activate the Pause function

A brief sound indicates that the shutter has been activated.



Image 6-7



The image projection can also be interrupted using the PAUSE key on the RCU.
To restart the image : press PAUSE

6.3.2 Freeze

Freezing the image

With the Freeze function, the image can be frozen.

To restart the image, reuse the Freeze function or press the **FREEZE** button on the remote.

How to freeze the image ?

1. Press **MENU** to activate the Tool bar
2. Press → to select *General*
3. Press ↓ to Pull down the General menu
4. Use ↑ or ↓ to select *Freeze* (image 6-8)
5. Press **ENTER** to activate the Freeze function

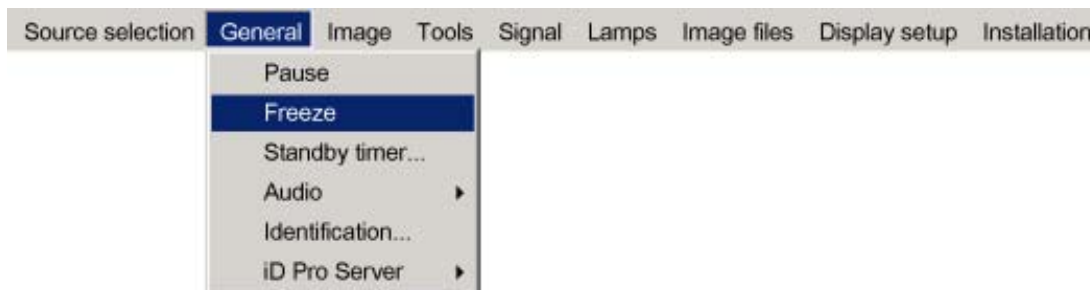

Image 6-8



The image can also be frozen using the FREEZE key on the RCU

6.3.3 Standby Timer

Purpose of the Standby Timer

If there is no signal, and the standby timer is enabled, a dialogbox is displayed and the projector will shut down after a determined time.

The countdown time can be set in a dialog box in a range from 180 to 3600 seconds (default value = 300). The Timer can also be disabled.

How to enable the timer ?

1. Press **MENU** to activate the Tool bar
2. Press → to select *General*
3. Press ↓ to Pull down the General menu
4. Use ↑ or ↓ to select *Standby Timer* (image 6-9)
5. Press **ENTER** to activate the function
On the screen appears a dialogbox (image 6-10)
6. Use ↑ or ↓ to select *Enabled*, a box surrounds the selected item, press **ENTER** to activate
7. Use ↑ or ↓ to browse to the input field
8. Use ← or → , the numeric keys on the remote or the keypad to change the countdown setting
9. Press **MENU** or **BACK** to exit or to go back to the previous menu



Image 6-9

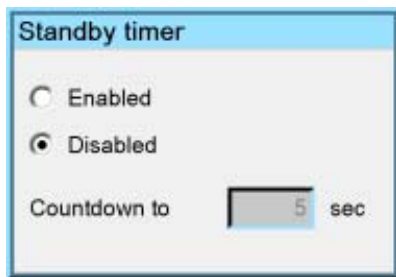

Image 6-10

6.3.4 Audio (Optional)

Overview

- Audio Setup
- Audio Settings

6.3.4.1 Audio Setup

What can be done ?

Layer 3 allows the input of 4 audio signals, each of them can be linked to the corresponding (video or data) source signal. It is also possible to link multiple audio signals to one video (or data) source signal, this can be useful in case of teleconferencing.

The configuration has to be done in the Audio Setup menu

Starting the Audio Setup menu

1. Press **MENU** to activate the Tool bar
2. Press **→** to select *General*
3. Press **↓** to Pull down the General menu
4. Use **↑** or **↓** to select *Audio setup* (image 6-11)
5. Press **ENTER**
 - A dialog box is displayed (image 6-12)
 - LED is red : audio input is mute
 - LED is green : input is active (linked image source is selected)
 - LED is orange : image source is not selected



Image 6-11

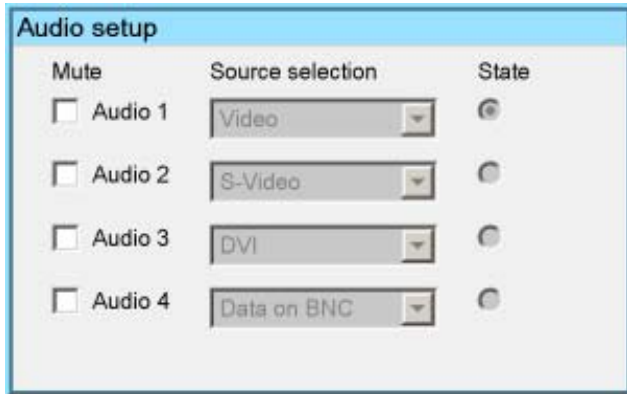

Image 6-12

How to mute an Audio channel ?

1. use the arrow keys to select the desired mute box
2. Press **ENTER**

How to link an audio input to a source ?

1. use the arrows to select the desired scroll box
2. Press **ENTER** to open the scroll box
3. use \uparrow or \downarrow to select the source
4. Press **ENTER**



When the source switching mode is the fade in/out mode, the audio switching will also be done using a fade in/out effect.

6.3.4.2 Audio Settings

Audio Settings

1. Press **MENU** to activate the Tool bar
2. Press \rightarrow to select *General*
3. Press \downarrow to Pull down the General menu
4. Use \uparrow or \downarrow to select *Audio setup* (image 6-13)
5. Press **ENTER**

A dialog box is displayed (image 6-14)

6. Use the arrow keys to select and change the settings

Note: The default value for the volume is 43, this corresponds to a gain factor of 1 (volume in = volume out).



Image 6-13

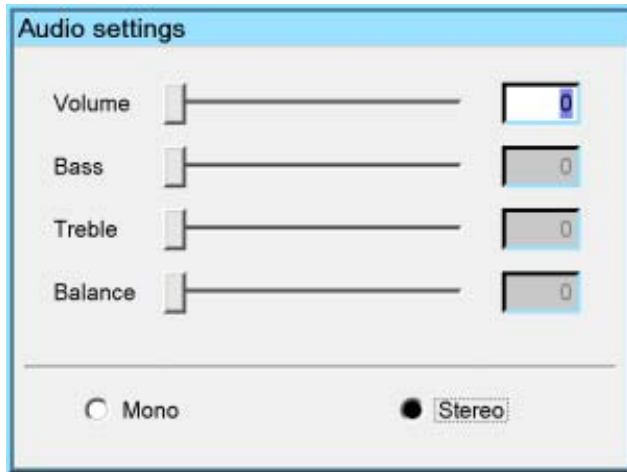

Image 6-14

6.3.5 Identification

The projector's identification screen

The identification screen displays the projector's main characteristics

How to display the identification screen ?

1. Press **MENU** to activate the Tool bar
2. Press → to select *General*
3. Press ↓ to Pull down the General menu
4. Use ↑ or ↓ to select *Identification* (image 6-15)
5. Press **ENTER** to activate the function
On the screen appears a text box.
In this case the projector is an iDR500 (image 6-16)
6. Press **MENU** or **BACK** to exit or to go back to the previous menu



Image 6-15

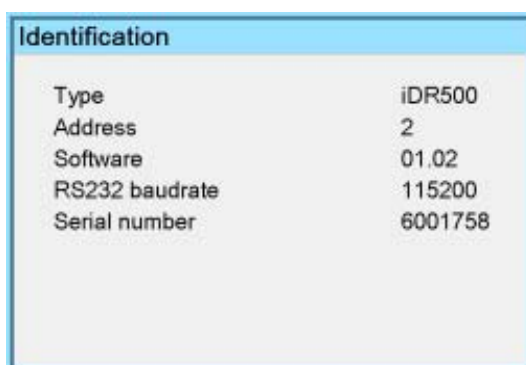

Image 6-16

6.4 Image menu

Overview

- Settings
- Aspect ratio
- Show native resolution
- Keystone
- Color temperature
- Filmmode detection (video only)
- White peaking
- Dynacolor™
- Blanking
- Input balance
- AGC on Video
- Manual Gain Control

6.4.1 Settings

Overview

- Contrast
- Brightness
- Color
- Tint (hue)
- Sharpness
- Gamma
- Phase
- Noise reduction

What can be done ?

Correct image settings are important for a good image reproduction. The image settings are made through a dialog box with a scroll bar. Minimal, maximal and actual values are indicated. These settings can also be done directly via the RCU's dedicated buttons, except for the sharpness.

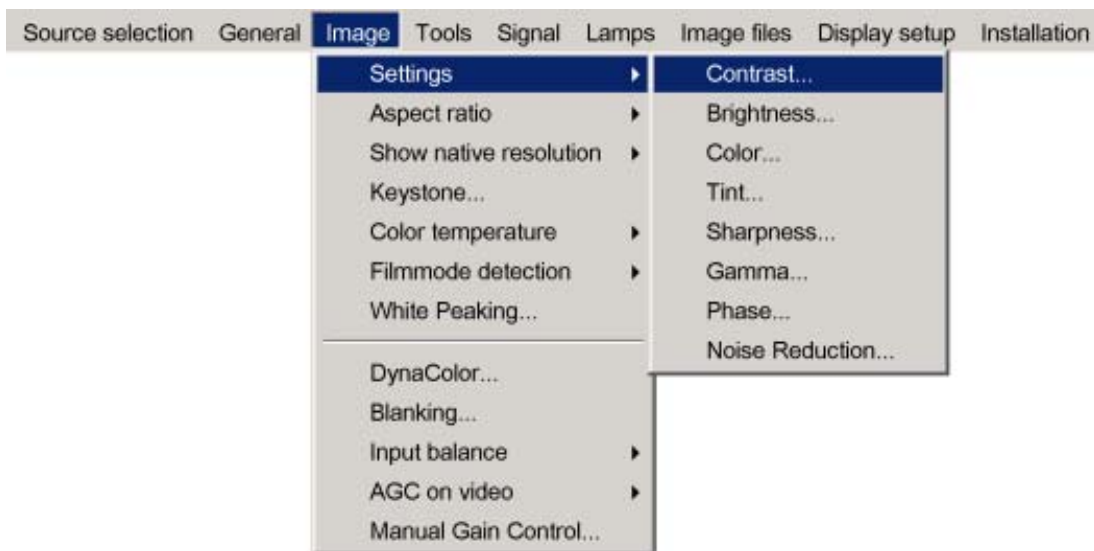

Image 6-17

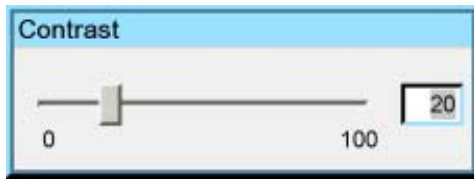

Image 6-18

6.4.1.1 Contrast

Contrast adjustment

Adjust the contrast to “brighten” the white parts of the image.



It is recommended to adjust the brightness before adjusting the contrast.

How to change the contrast

1. Press **MENU** to activate the Toolbar
2. Press → to select the *Image* item
3. Press ↓ to Pull down the *Image* menu
4. Use ↑ or ↓ to select *settings*
5. Press → to pull down the menu
6. Use ↑ or ↓ to select *Contrast*
7. Press **ENTER**

On the screen appears now a sliderbox (image 6-19)

8. Use ← or → , the numeric keys on the remote, or the keypad to change the contrast

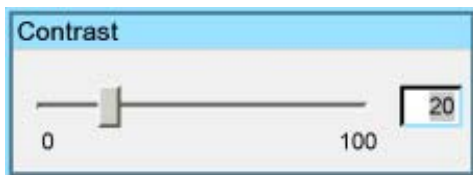

Image 6-19

6.4.1.2 Brightness

Brightness adjustment

Adjusting the brightness will affect the dark areas of the image. Increase the brightness to “lighten” up the parts that are too dark.

How to change the Brightness ?

1. Press **MENU** to activate the Toolbar
2. Press → to select the *Image* item
3. Press ↓ to Pull down the *Image* menu
4. Use ↑ or ↓ to select *settings*
5. Press → to pull down the menu
6. Use ↓ or ↑ to select *Brightness*
7. Press **ENTER**

On the screen appears now a sliderbox (image 6-20)

8. Use ← or → , the numeric keys on the remote, or the keypad to change the Brightness

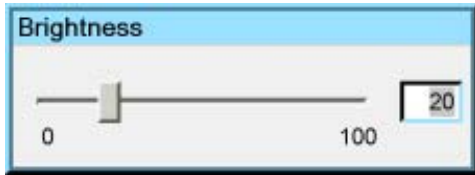

Image 6-20

6.4.1.3 Color

Color adjustment

Adjust the color to obtain more or less saturated colors.

How to change the Color ?

1. Press **MENU** to activate the Toolbar
2. Press **→** to select the *Image* item
3. Press **↓** to Pull down the *Image* menu
4. Use **↑** or **↓** to select *settings*
5. Press **→** to pull down the menu
6. Use **↓** or **↑** to select *Color*
7. Press **ENTER**

On the screen appears now a sliderbox (image 6-21)

8. Use **←** or **→**, the numeric keys on the remote, or the keypad to change the Color



Image 6-21

6.4.1.4 Tint (hue)

How to change the Tint ?

1. Press **MENU** to activate the Toolbar
2. Press **→** to select the *Image* item
3. Press **↓** to Pull down the *Image* menu
4. Use **↑** or **↓** to select *settings*
5. Press **→** to pull down the menu
6. Use **↓** or **↑** to select *Tint*
7. Press **ENTER**

On the screen appears now a sliderbox

8. Use **←** or **→**, the numeric keys on the remote, or the keypad to change the Tint

6.4.1.5 Sharpness

How to change the sharpness ?

1. Press **MENU** to activate the Toolbar
2. Press **→** to select the *Image* item
3. Press **↓** to Pull down the *Image* menu
4. Use **↑** or **↓** to select *settings*
5. Press **→** to pull down the menu
6. Use **↓** or **↑** to select *sharpness*

7. Press **ENTER**

On the screen appears now a sliderbox

8. Use ← or → , the numeric keys on the remote, or the keypad to change the sharpness

6.4.1.6 Gamma

How to change the Gamma

1. Press **MENU** to activate the Toolbar
2. Press → to select the *Image* item
3. Press ↓ to Pull down the *Image* menu
4. Use ↑ or ↓ to select *settings*
5. Press → to pull down the menu
6. Use ↓ or ↑ to select *Gamma*
7. Press **ENTER**

On the screen appears now a sliderbox

8. Use ← or → , the numeric keys on the remote, or the keypad to change the Gamma

6.4.1.7 Phase

Phase adjustment

A bad phase adjustment will result in bad transitions and sometimes noise (text can end to be unclear).

How to change the Phase ?

1. Press **MENU** to activate the Toolbar
2. Press → to select the *Image* item
3. Press ↓ to Pull down the *Image* menu
4. Use ↑ or ↓ to select *settings*
5. Press → to pull down the menu
6. Use ↓ or ↑ to select *Phase*
7. Press **ENTER**

On the screen appears now a sliderbox (image 6-22)

8. Use ← or → , the numeric keys on the remote, or the keypad to change the Phase

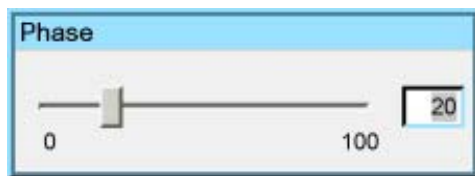

Image 6-22

6.4.1.8 Noise reduction

How to change the Noise reduction ?

1. Press **MENU** to activate the Toolbar
2. Press → to select the *Image* item
3. Press ↓ to Pull down the *Image* menu
4. Use ↑ or ↓ to select *settings*
5. Press → to pull down the menu
6. Use ↓ or ↑ to select *Noise reduction*
7. Press **ENTER**

On the screen appears now a sliderbox

8. Use ← or → , the numeric keys on the remote, or the keypad to change the Noise reduction setting.

6.4.2 Aspect ratio

Aspect ratios

The standard aspect ratio used in broadcast television is the 4:3 ratio. However, most of the DVD sources use nowadays the widescreen 16:9 or even the cinemascope 2.35:1 aspect ratio.

Some DVD sources may even use the anamorphic 16:9 or anamorphic 2.35:1 to take advantage of the higher vertical resolution offered by the 4:3 ratio. The "anamorphic" term means that the original widescreen image is squeezed in order to fit the 4:3 aspect ratio.

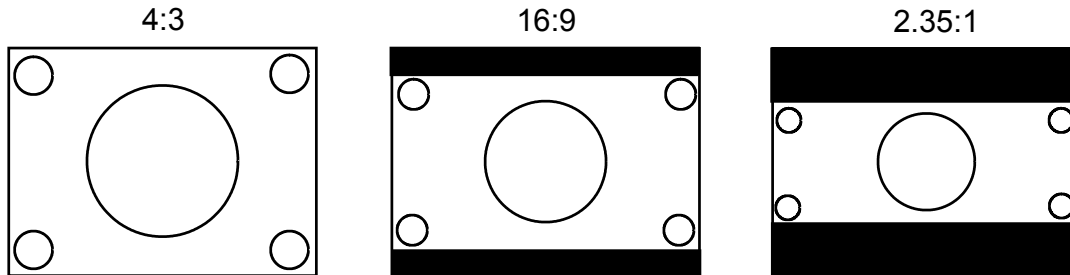

Image 6-23
Common non- anamorphic aspect ratios in DVD sources

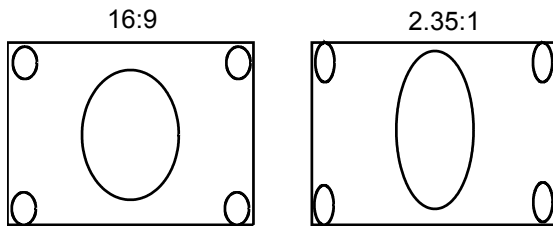

Image 6-24
Anamorphic aspect ratios in DVD sources

What can be done ?

The aspect ratio setting forces the projector to project an image using a defined aspect ratio :

- 4:3
- 16:9
- 5:4
- Auto



The settings do not refer to the aspect ratio of the source !

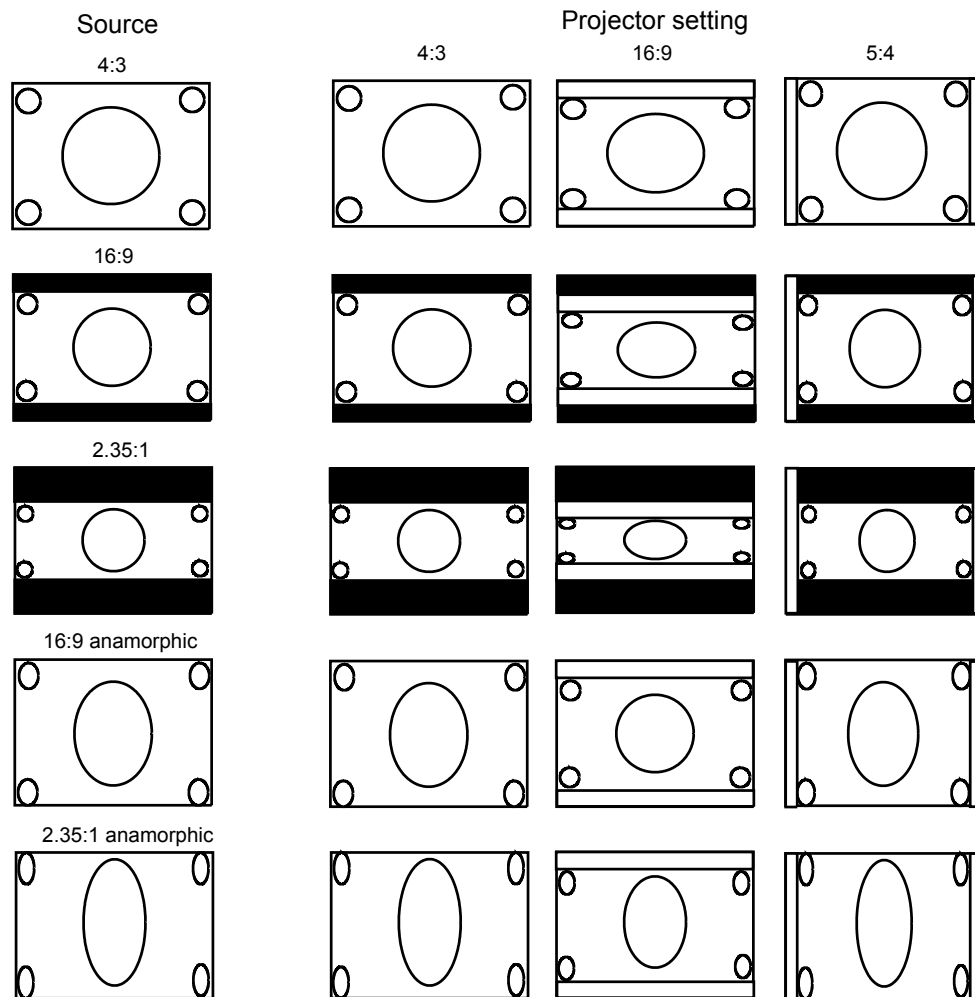

Image 6-25
Possible aspect ratio settings and their effect on different sources in the iQ.

We can conclude that the thumb rule for DVD projection is to always leave the projector in 4:3 format except when dealing with anamorphic sources where the 16:9 setting allows the best reproduction.

The Auto function calculates an aspect ratio based on the information stored in the image files.



Selecting Auto in case of a Video source may shrink the image horizontally

How to change the Aspect ratio ?

1. Press **MENU** to activate the Tool bar
2. Press **→** to select *Image*
3. Press **↓** to Pull down the *Image* menu (image 6-26)
4. Use **↑** or **↓** to select *Aspect ratio*
5. Use **→** open the *Aspect ratio* menu
6. Use **↑** or **↓** to select the desired ratio
7. Press **ENTER** to confirm

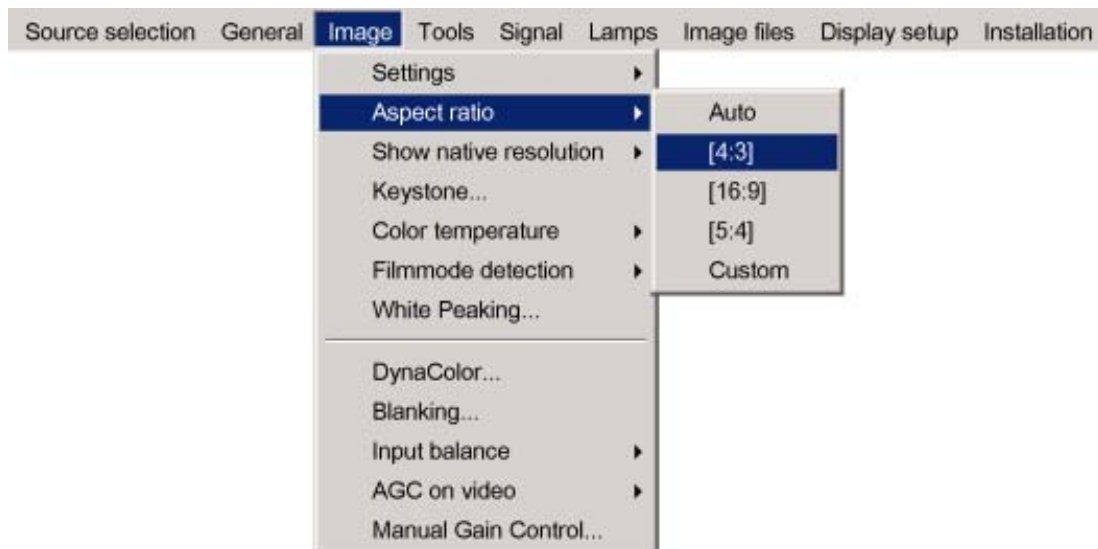

Image 6-26



The aspect ratio settings are greyed out in case the *Show native resolution* or the *Full screen representation* setting is enabled.

How to set a custom Aspect ratio ?

1. Press **MENU** to activate the Tool bar
2. Press → to select *Image*
3. Press ↓ to Pull down the *Image* menu
4. Use ↑ or ↓ to select *Aspect ratio*
5. Use → open the *Aspect ratio* menu
6. Use ↑ or ↓ to select *Custom*
7. Press **ENTER** to confirm
A dialog box is displayed (image 6-27)
8. Enter the values for width and height of the image
The image aspect ratio is updated.

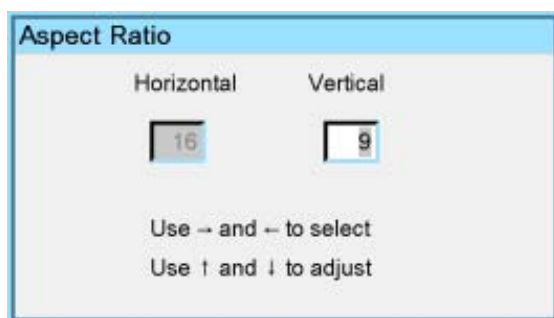

Image 6-27

6.4.3 Show native resolution



Reality(SXGA+)

Native resolution of the LCD panels = 1400 x 1050 pixels (4:3)

What can be done ?

The aim here is to always show the resolution of the source independently of the resolution of the LCD panels. This way better image reproduction is obtained since no up or down scaling is done on the source.

Note that native resolution refers here to the source and does thus only have sense when handling data sources (greyed out for video sources).

Depending on the type of projector the "show native resolution" function will handle the sources as follows:

Source			Projected image		
Name	Ratio	Resolution	Ratio	Resolution	Display
xga	4:3	1024x768	4:3	1024x768	image centered +side blanked
sxga	5:4	1280x1024	5:4	1280x1024	image centered +side blanked
sxga+	4:3	1400x1050	4:3	1400x1050	image centered
uxga	4:3	1600x1200	4:3	1600x1200	scroll image

Table 6-1
Show native resolution = ON



The **Full screen representation** function on the other hand forces to use the complete native resolution of the LCD panels.

How to enable the "Show native resolution" function?

1. Press **MENU** to activate the Tool bar
2. Press **→** to select the *Image* item
3. Press **↓** to Pull down the *Image* menu
4. Use **↑** or **↓** to select *Show native resolution* (image 6-28)
5. Press **→** to pull down the menu
6. Use **↓** or **↑** to select *On*
7. Press **ENTER**

A white bullet shows the selection

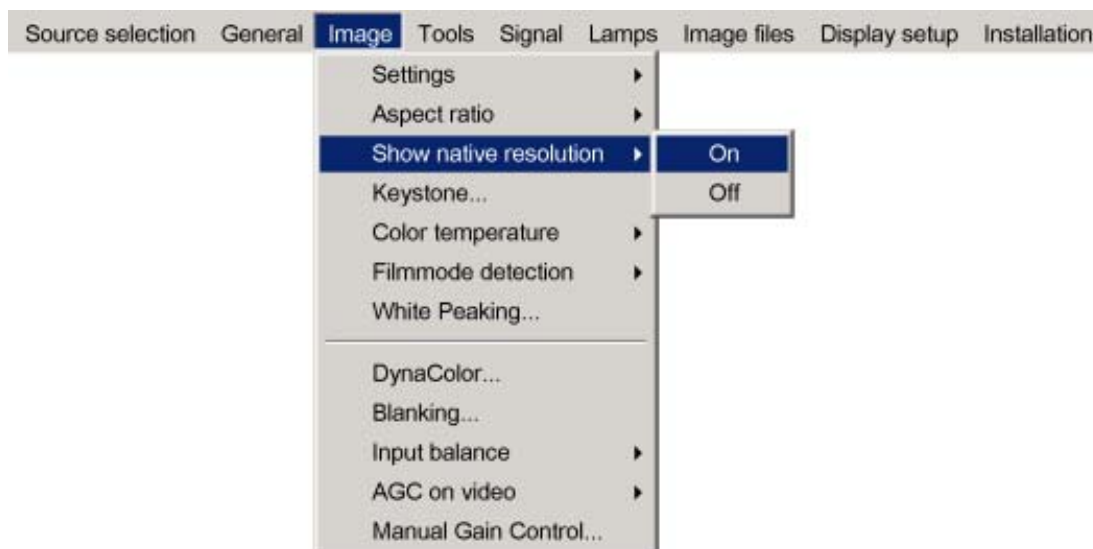

Image 6-28



The default mode is used if the *Show native resolution* and the *Full screen representation* are off.

The default mode shows always the native ratio and forces the native resolution of the panels (part of the image blanked where needed)



When show native resolution is ON and the resolution of the source is higher than the panel resolution, use the arrow keys to scroll through the image (pan).

6.4.4 Keystone

What can be done ?

The Keystone adjustment is used to align the image, this can be necessary when projecting under a non standard angle

How to perform a Keystone correction ?

1. Press **MENU** to activate the Tool bar
2. Press **→** to select *Image*
3. Press **↓** to Pull down the *Image* menu
4. Use **↑** or **↓** to select *Keystone* (image 6-29)
5. Press **ENTER** to confirm

A sliderbox is displayed . (image 6-30)

Use **←** or **→**, the numeric keys on the remote, or the keypad to adjust the keystone.

The Top and bottom adjustments affect the image differently. (image 6-31, image 6-32)

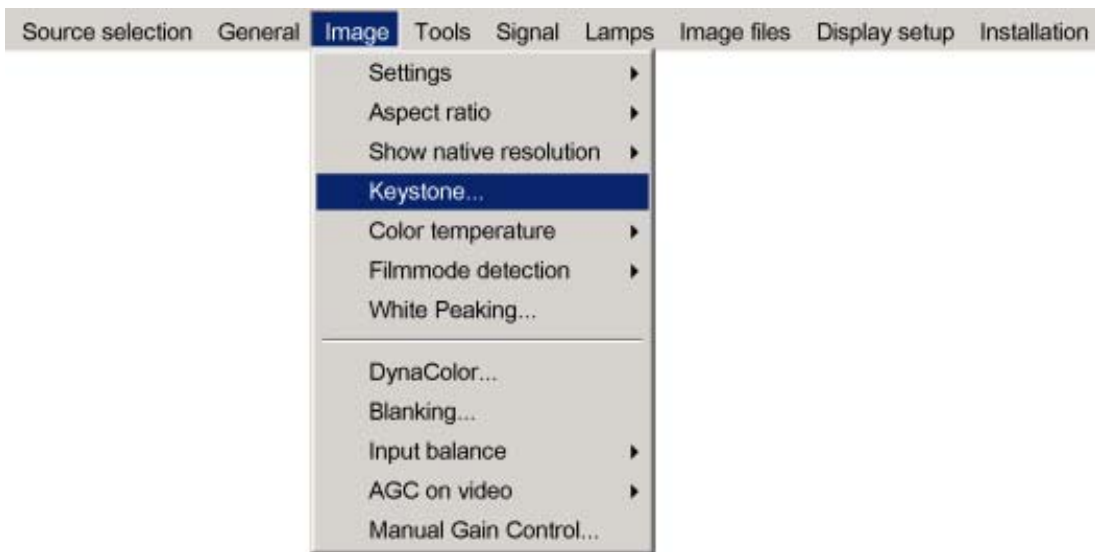

Image 6-29

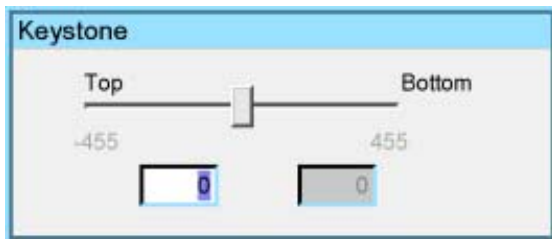

Image 6-30

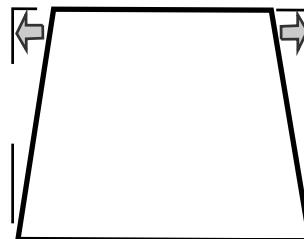

Image 6-31
Top adjustment of the keystone

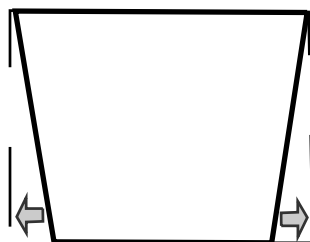

Image 6-32
Bottom adjustment of the keystone

6.4.5 Color temperature

What can be done ?

The color temperature can be selected according to the type of source:

There are 4 different preset color temperatures:

- Projector white
- computer : 9300 K
- Video : 6500 K
- Film : 5400 K
- Broadcast : 3200 K

These calibrated presets can be selected and will provide optimum color tracking, the projector allows however the setting of a personal color temperature, this is done in *custom*

How to select a preset color temperature ?

1. Press **MENU** to activate the Tool bar
2. Press → to select the *Image* item
3. Press ↓ to Pull down the *Image* menu
4. Use ↑ or ↓ to select *Color temperature*
5. Press → to pull down the menu
6. Use ↓ or ↑ to select the desired preset color temperature
7. Press **ENTER**

The color temperature of the image is adapted and a white bullet shows the active setting.

How to start up the custom color temperature ?

1. Press **MENU** to activate the Tool bar
2. Press → to select the *Image* item
3. Press ↓ to Pull down the *Image* menu
4. Use ↑ or ↓ to select *Color temperature*
5. Press → to pull down the menu
6. Use ↓ or ↑ to select *custom*
7. Press **ENTER**

A slider box for the red custom setting is displayed as well as a wizard text box in the lower part of the screen. (image 6-33)

Follow the instructions on the wizard textbox. (image 6-34)

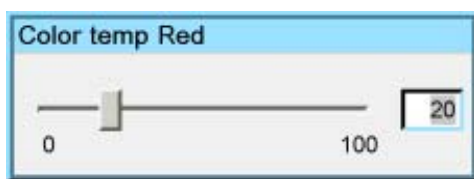

Image 6-33

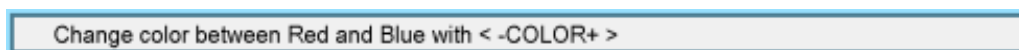

Image 6-34

6.4.6 Filmmode detection (video only)

What can be done ?

Some sources like common DVD material are derived from cinema 24 Hz sources (2/2 or 3/2 pull down method).

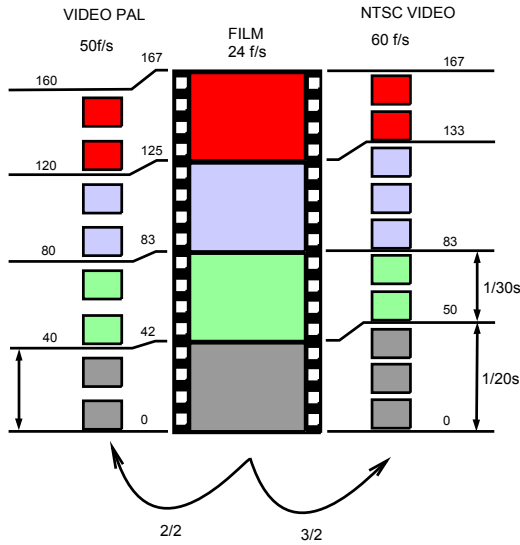

Image 6-35
film to video conversion: 2/2 and 2/3 pull down method

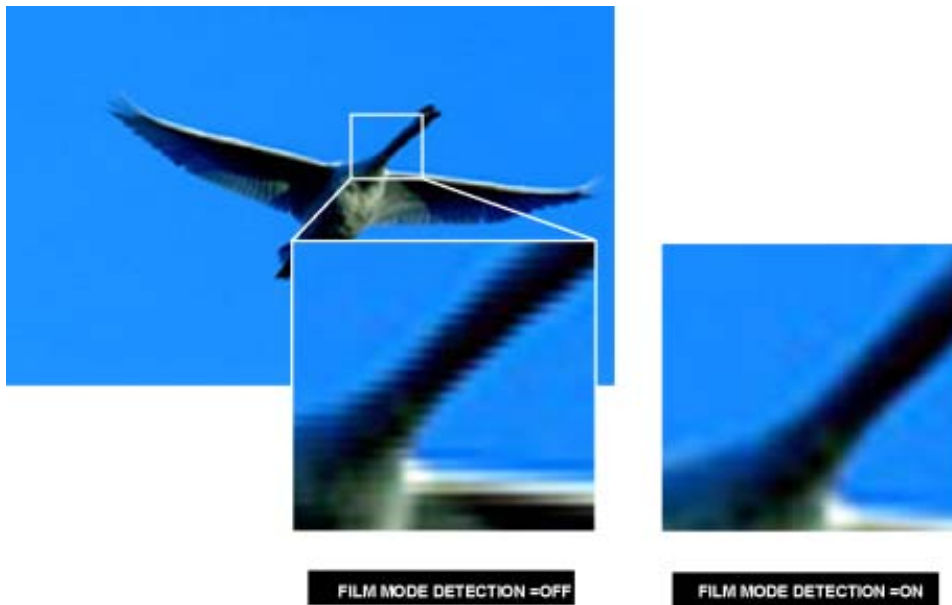

Image 6-36

The filmmode detection insures that these converted signals are shown without artefacts, especially motion artefacts due to bad de-interlacing.



This function may cause undesired effects on standard sources, therefore it can be disabled (OFF) at any time

Enabling/disabling the filmmode detection

1. Press **MENU** to activate the Tool bar
2. Press **→** to select the *Image* item
3. Press **↓** to Pull down the *Image* menu
4. Use **↑** or **↓** to select *Filmmode detection*
5. Press **→** to pull down the menu
6. Use **↓** or **↑** to enable or disable the Filmmode detection (image 6-37)
7. Press **ENTER**

A white bullet shows the active setting

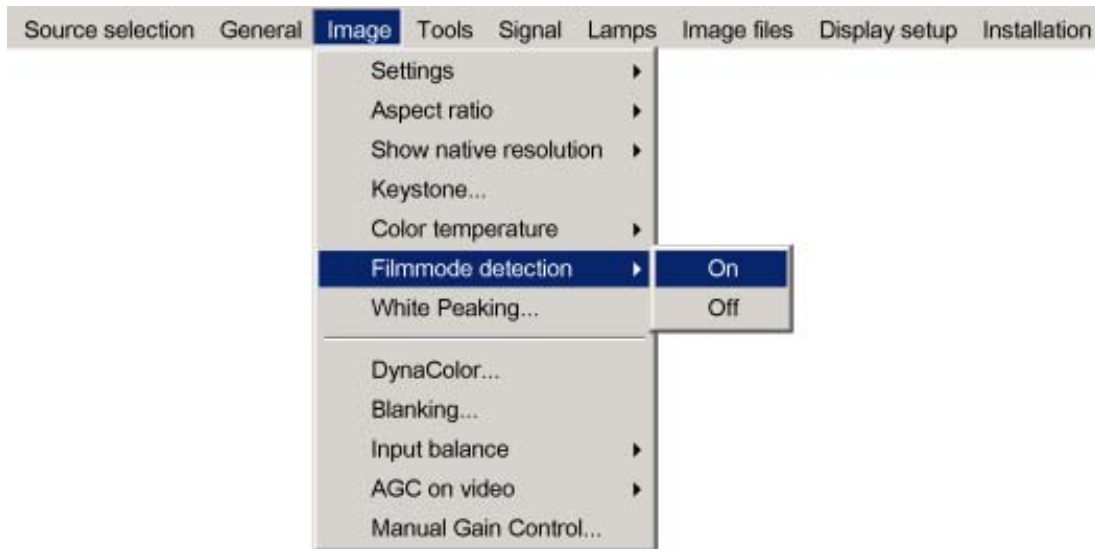

Image 6-37

6.4.7 White peaking

White peaking

White peaking function will allow you to adjust the “white level” of the colors i.e. increasing the white peaking will increase the overall brightness of the image. Note that increasing the white peaking will decrease the color saturation.

How to adjust the White peaking level ?

1. Press **MENU** to activate the Tool bar
2. Press → to select the *Image* item
3. Press ↓ to Pull down the *Image* menu
4. Use ↑ or ↓ to select *White peaking* (image 6-38)
5. Press **ENTER**

A slider box is displayed (image 6-39)

6. Adjust the white peaking to the desired value

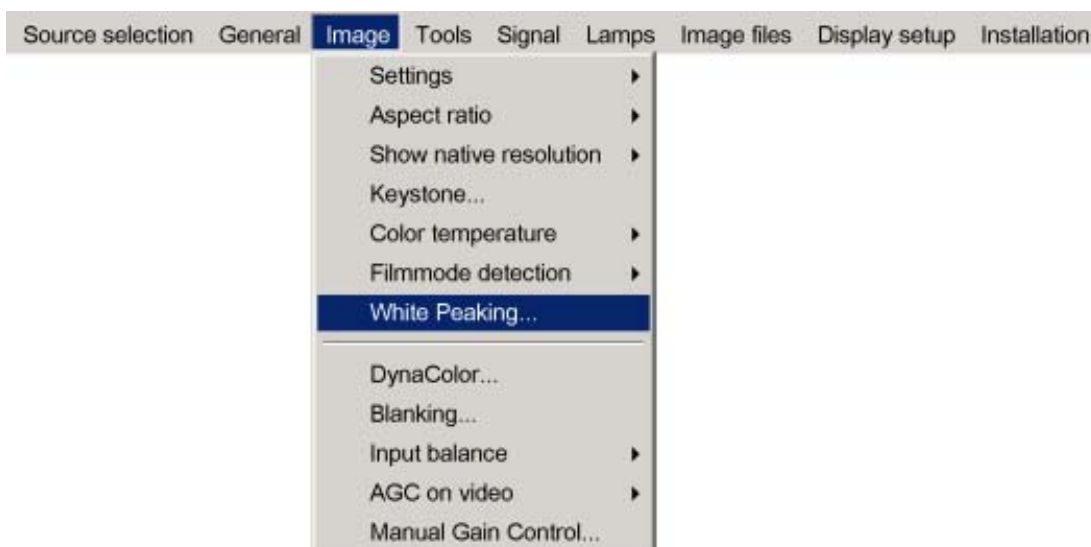

Image 6-38

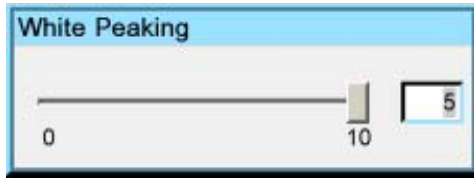

Image 6-39

6.4.8 Dynacolor™

What can be done?

DynaColor™ will eliminate channel-to-channel color variations.

How to define color?

The CIE chromaticity diagram is one way to plot the colors the human eye can see.

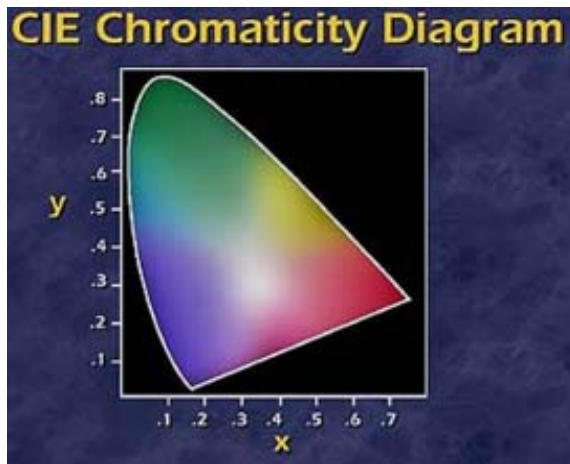

Image 6-40
The CIE chromaticity diagram

A projector can only reproduce a certain color gamut within this diagram. This color gamut is defined by the triangle formed by the x, y coordinates of Red Green and Blue. These parameters are used by the DynaColor™ adjustment.

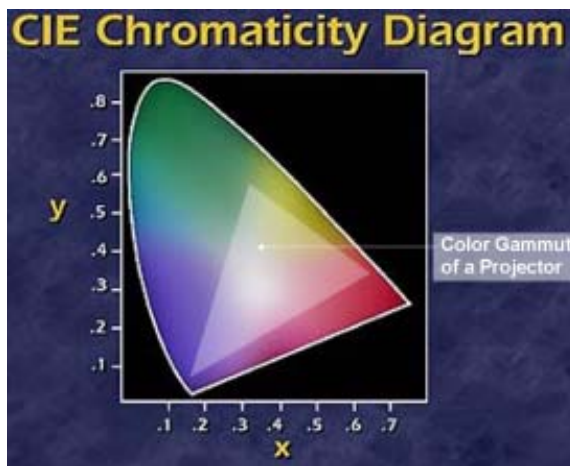

Image 6-41
The projector color gamut is defined by the triangle formed by the x, y coordinates of Red Green and Blue

Due to the tolerance on optical components the x, y values of this color gamut of each projector will differ.

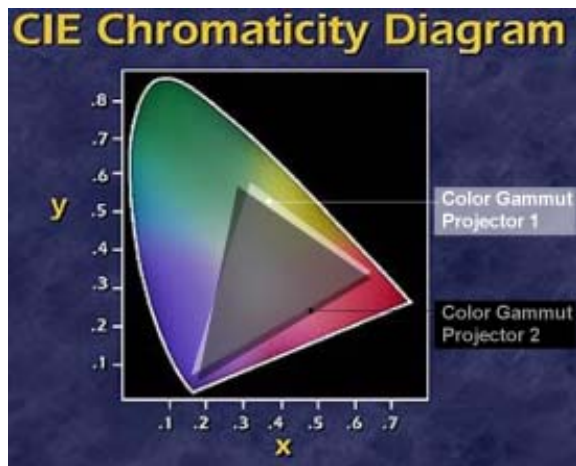

Image 6-42
The color gamut of each projector will differ

When working with a multichannel setup, these color differences between different projectors can be smoothed out by matching the color gamuts of the different projectors to a Common Color Gamut.

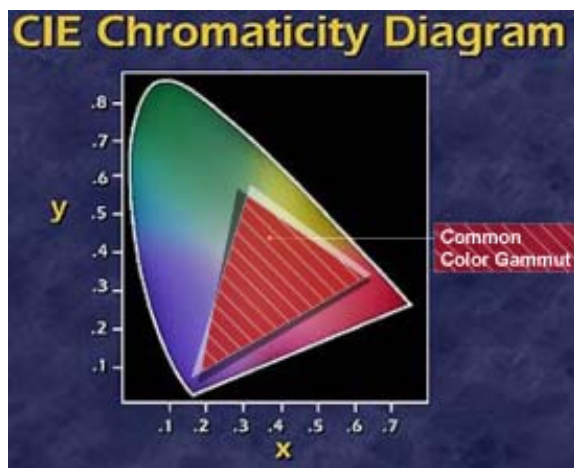

Image 6-43
Common Color Gamut

The Common Color Gamut

In a basic setup with 2 projectors, the perimeter of the Common Color Gamut is described by the 6 points of intersection of the 2 separate color gamuts.

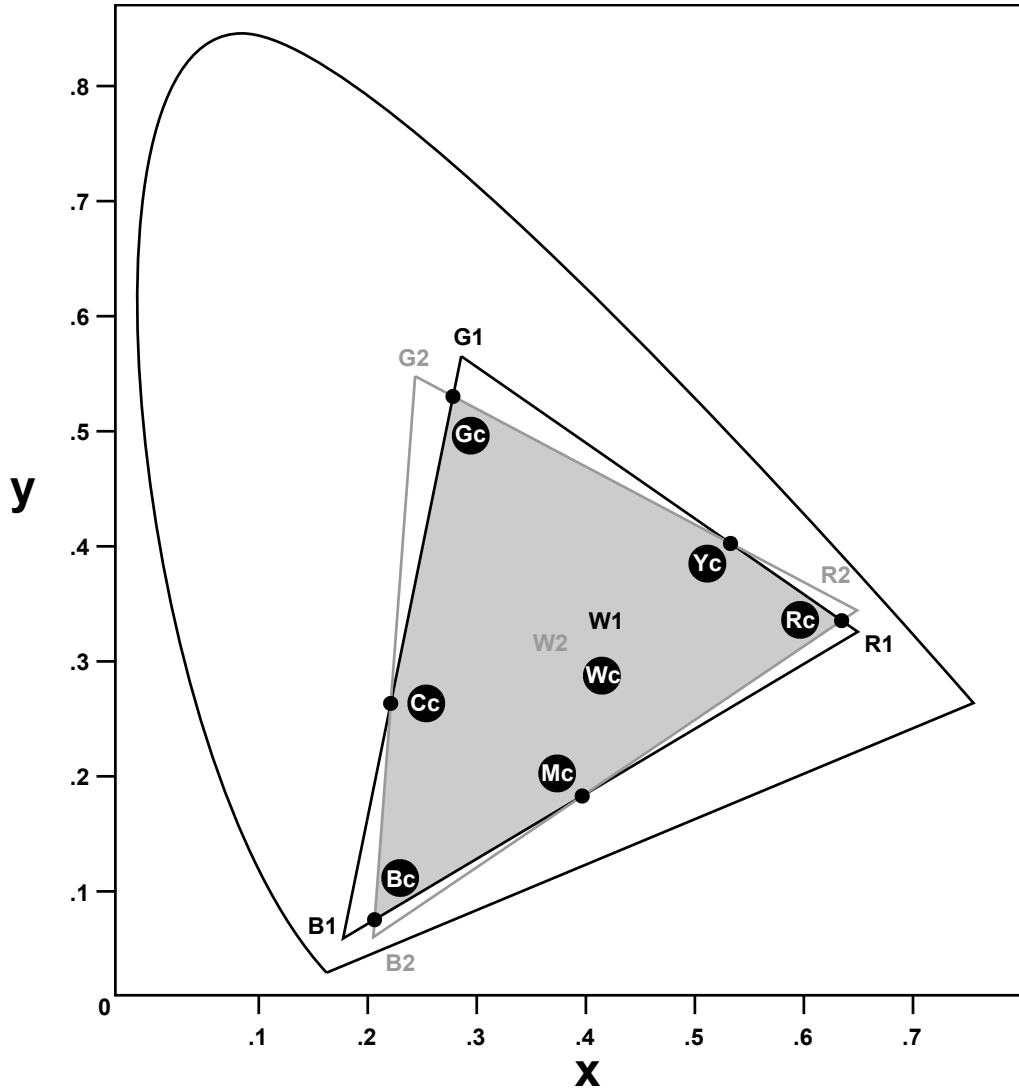

Image 6-44
The Common Color Gamut

- R1 Red projector 1
- R2 Red projector 2
- G1 Green Projector 1
- G2 Green Projector 2
- B1 Blue Projector 1
- B2 Blue Projector 2
- W1 White Projector 1
- W2 White Projector 2
- Rc Red Common Color Gamut
- Gc Green Common Color Gamut
- Bc Blue Common Color Gamut
- Cc Cyan Common Color Gamut
- Mc Magenta Common Color Gamut
- Yc Yellow Common Color Gamut
- Wc White Common Color Gamut

The following parameters can be adjusted within DynaColor™:

- the x, y coordinates and g(Light Output) of the 6 Common Color Gamut perimeter points.
- the x, y coordinates and g(Light Output) of the White point of the Common Color Gamut.

How to Start up Dynacolor™?

1. Press the **MENU** key to activate the Menu bar.
2. Push the cursor key ← or → to highlight *Image* in the menubar.
3. Push the ↓ key to pull down the *Image* menu.
4. Push the cursor key ↑ or ↓ to highlight *Dynacolor* and press **ENTER** to select. (image 6-45)
The Dynacolor dialog box will be displayed. (image 6-46)

5. Push the cursor key ← or → select enable/diasable and then **ENTER**.

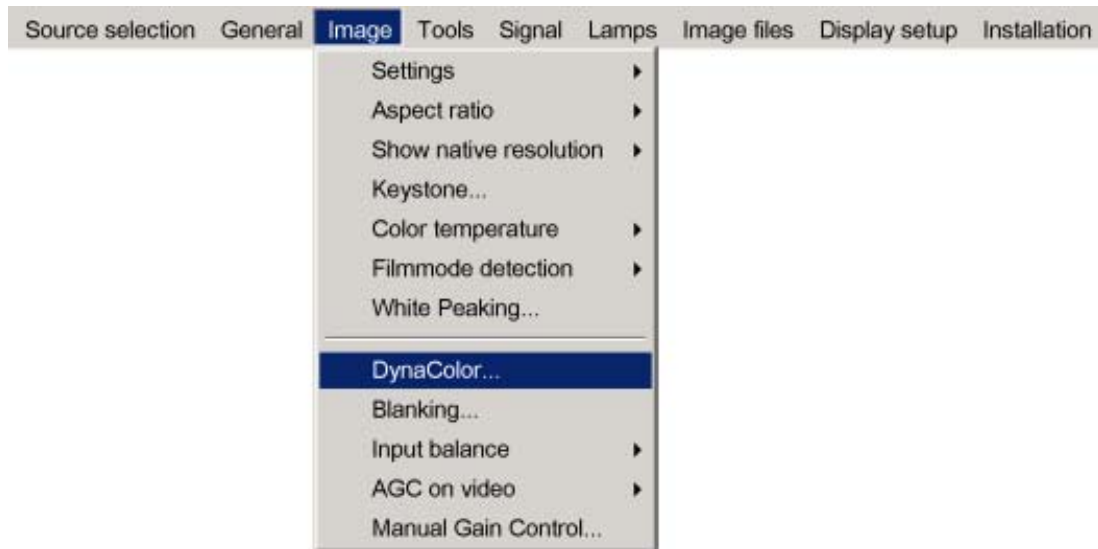

Image 6-45

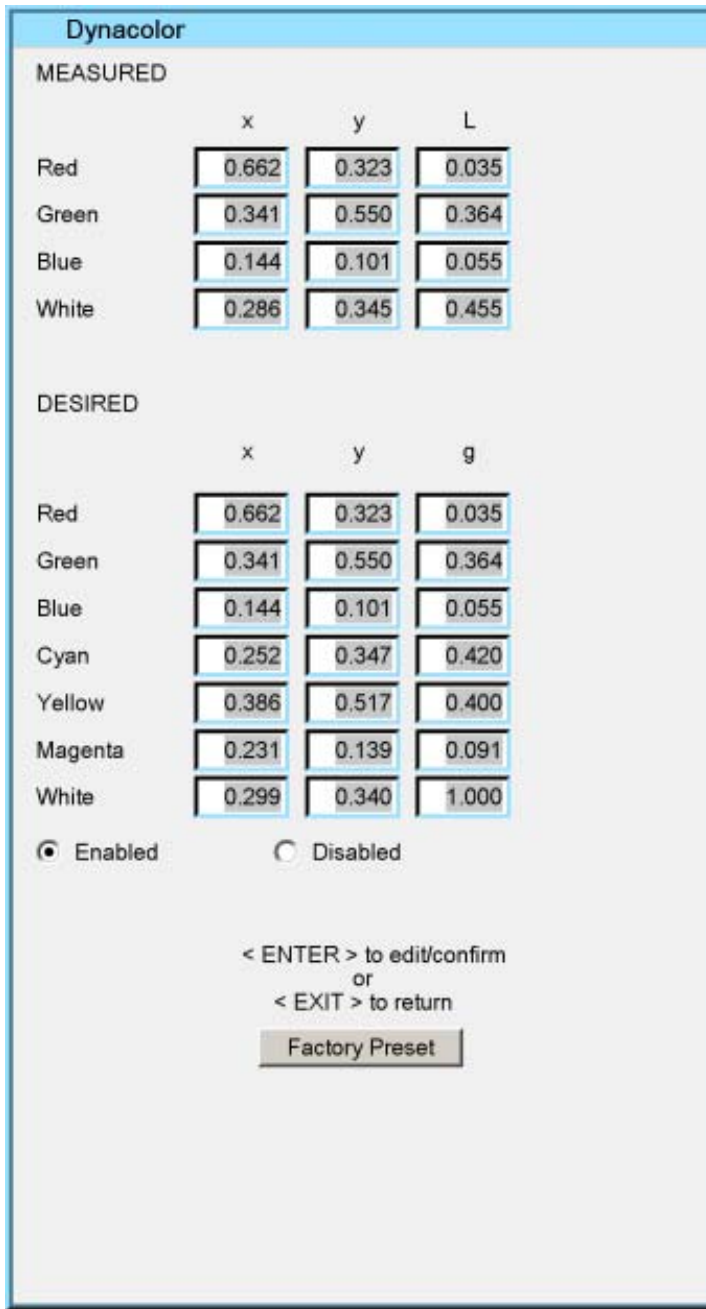

Image 6-46

Dynacolor™ g (Light Output) Value

The value g in the Dynacolor™ interface represents a relative light output.

g=1 is the maximum available light output.



Assume we have a projector. L=1 in the Dynacolor™ interface will correspond with a 'maximum full white light' output of x Lumens.



Important ! In the projectors iD R600 and iD Pro R600 (R9010340 and R9010350) the measuring is done with white peaking = 0.

In the projectors iD R600+ and iD Pro R600+(R9010341 and R9010351) however, the white peaking must be 10 during the measurement.

The dialogbox shown here are as displayed in the iD R600 and iD Pro R600 (with the field White).The dialogbox displayed in the iD R600+ and iD Pro R600+ contain the field White+ instead of White.

The Dynacolor™ Interface

Following parameters are available in the Dyancolor™ Interface:

Measured Values	These are the colors the projector displays when no color changes are made
Red x, y	Coördinates for the Red point
Green x, y	Coördinates for the Green point
Blue x, y	Coördinates for the Blue point
White x, y	Coördinates for the White point
Red L	Red Light output
Green L	Green Light output
Blue L	Blue Light output
White L	White Light Output

Desired Values	These are the colors you want the projector to display when the status is enabled
Red x, y	Coördinates for the Red point
Green x, y	Coördinates for the Green point
Blue x, y	Coördinates for the Blue point
Cyan x, y	Coördinates for the Cyan point
Yellow x, y	Coördinates for the Yellow point
Magenta x, y	Coördinates for the Magenta point
White x, y	Coördinates for the White point
Red g	Red Light Gain
Green g	Green Light Gain
Blue g	Blue Light Gain
Cyan g	Cyan Light Gain
Yellow g	Yellow Light Gain
Magenta g	Magenta Light Gain
White g	White Light Gain

Status	Enables or disables Dynacolor™
Factory Preset	Sets the measured parameters back to the factory preset for the current set

Basic Dynacolor™ Adjustment

We assume we have a basic setup with 2 projectors, the Dynacolor™ adjustment is done by using only the Dynacolor™ menu:

1. Enable Dynacolor™ on both projectors.
2. Assume the first projector has the following measured values. (image 6-47)
3. Assume the second projector has the following measured values. (image 6-48)
4. We start by setting both projectors to the common red coordinate.
Tip: Draw a quick sketch of both gamuts as a graphical help. (image 6-49)
5. Display the internal color bar pattern on both projectors.
6. In the desired values, adjust the red coordinate to a common value for both projectors.
Tip: The color bar of the adjusted coordinate will no longer be displayed in case the coordinate is not present within the gamut of the adjusted projector e.g. with the desired values for red set to $x=660$ and $y=318$. (image 6-50)

6. Advanced

Select a coordinate that is present in the common gamut e.g. with the desired values for red set to x=633 and y= 328. (image 6-51)

7. Repeat step 5 to 6 for all coordinates on both projectors.

Both projectors will now operate within the same color gamut.

Dynacolor

MEASURED

	x	y	L
Red	0.662	0.323	0.035
Green	0.341	0.550	0.364
Blue	0.144	0.101	0.055
White	0.286	0.345	0.455

DESIRED

	x	y	g
Red	0.662	0.323	0.035
Green	0.341	0.550	0.364
Blue	0.144	0.101	0.055
Cyan	0.252	0.347	0.420
Yellow	0.386	0.517	0.400
Magenta	0.231	0.139	0.091
White	0.299	0.340	1.000

Enabled Disabled

< ENTER > to edit/confirm
or
< EXIT > to return

Factory Preset

Image 6-47

Dynacolor

MEASURED

	x	y	L
Red	0.658	0.305	0.042
Green	0.327	0.546	0.337
Blue	0.139	0.100	0.045
White	0.290	0.353	0.423

DESIRED

	x	y	g
Red	0.658	0.330	0.042
Green	0.327	0.546	0.336
Blue	0.139	0.100	0.046
Cyan	0.246	0.356	0.381
Yellow	0.381	0.505	0.377
Magenta	0.251	0.148	0.086
White	0.304	0.351	1.000

Enabled Disabled

< ENTER > to edit/confirm
or
< EXIT > to return

Image 6-48

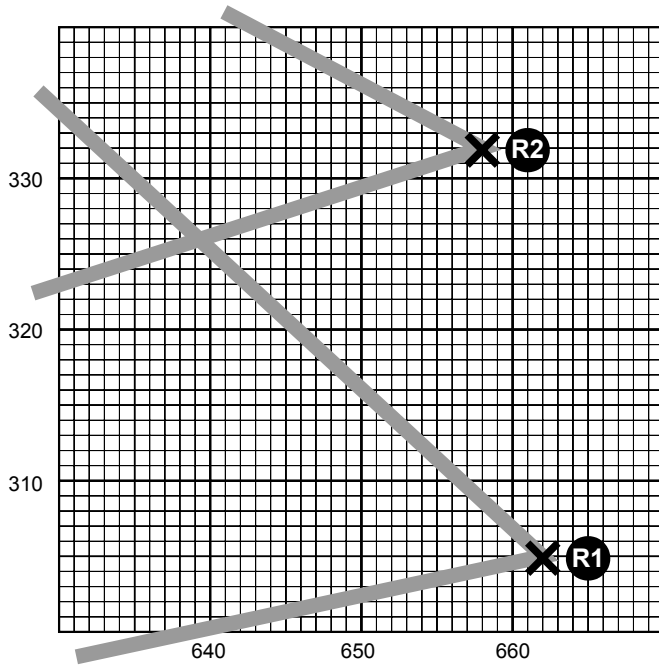

Image 6-49
Red coordinates for both projectors

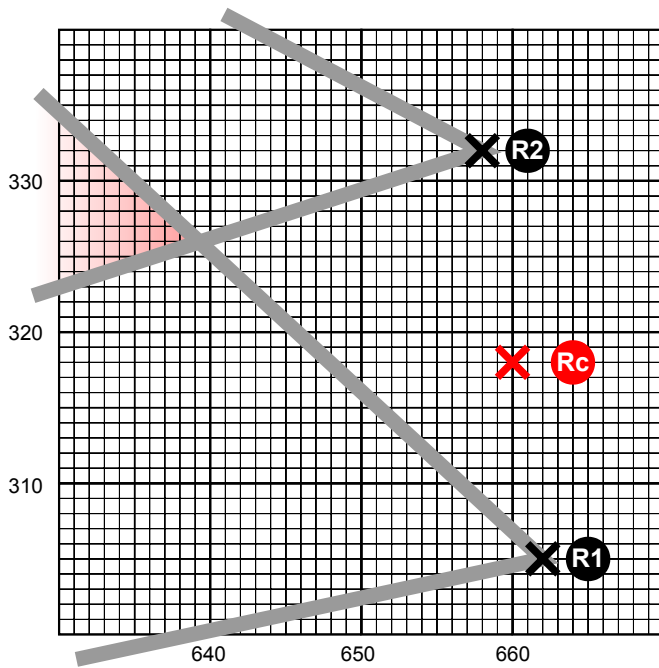

Image 6-50
Coordinate is not present within the gamut of the adjusted projector

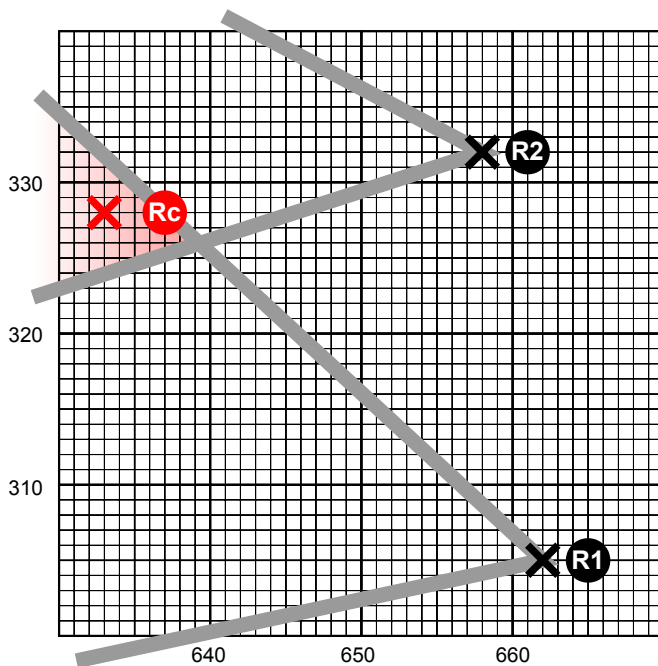

Image 6-51
Select a coordinate that is present in the common gamut



Another way to determine the new coordinates is to use the DynacolorTool (software tool running on a laptop or PC), contact Barco for more information.

6.4.9 Blanking

Blanking in the Image menu

The blanking in general allows to blank unwanted video information (noise in the top or bottom of the image).

The blanking in the image menu is the same as in the Display settings menu except for the fact that here the blanking settings are **stored** in the image files. In other words each custom file or source has its own blanking values.

See the blanking procedure in the Display settings menu.



If the selected source is not entirely displayed always check first the blanking settings in the image menu since the active custom file may contains blanking.

6.4.10 Input balance

Introduction: Unbalanced color signals

When transporting signals, there is always a risk of deterioration of the information contained in the signals.

The alterations of the three color signals will happen independently i.e. the colors will end to be unbalanced,

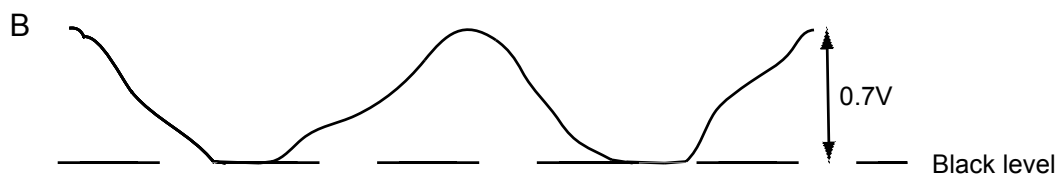

Image 6-52

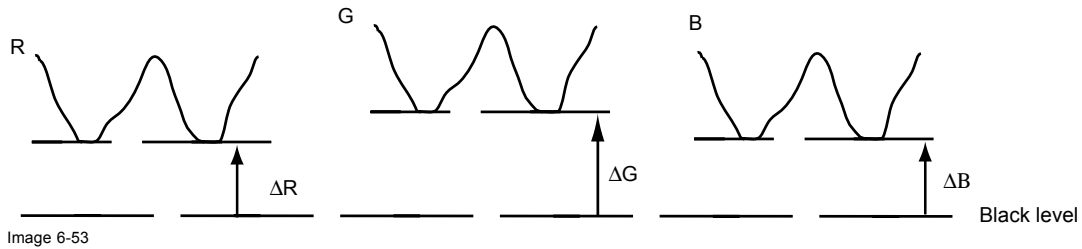

Image 6-53

The objective of input balancing

The objective in input balancing is to “set” the same black level and the same white level for the three colors of a particular input source.



Black level setting : brightness

White level setting : contrast

The same absolute black and white level for the three colors allows the same reference for Brightness and contrast control of the picture !

These two references also set the range in which the ADC will work for that particular source (this explains also why each input balance setting is linked to a particular source and thus saved in the image file).

How can it be done ?

To balance the three color signals of a particular source there are conditions; in fact we must know the black and the white level of the source i.e. :

1. the source in question must be able to generate a white signal, ideally a 100% white (background) full screen pattern
2. the source in question must be able to generate a black signal, ideally a 100 % black (background) full screen pattern

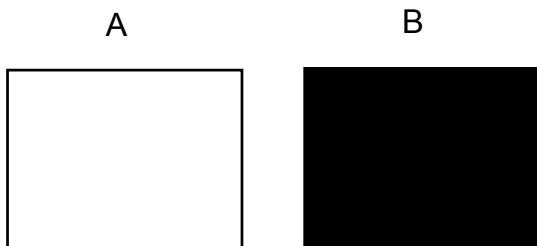

Image 6-54

White balance : In the projector, we will set the contrast for each color until we get a 100% light output picture when projecting a 100% white image (image A)

Black balance : In the projector, we will set the brightness for each color until we get a 0% light output picture when projecting a 100% black image (image B).



The changeover from min to max is indicated by the apparition of bright spots also called “digital noise”



An alternative to a full screen White/black pattern is the standard gray scale pattern, the white bar will be used for white balance and the black bar for black balance.

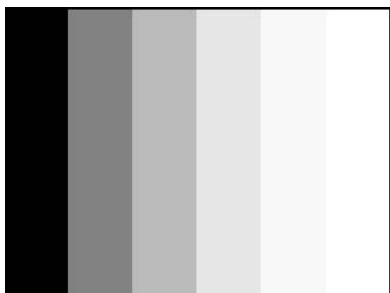

Image 6-55

Black balance

1. Connect the source you want to project
 2. Press **MENU** to activate the Tool bar
 3. Press → to select the *Image* item
 4. Press ↓ to Pull down the *Image* menu
 5. Use ↑ or ↓ to select *Input balance*
 6. Press → to pull down the menu
 7. Use ↓ or ↑ to select *Black balance* (image 6-56)
 8. Adjust the red black level on a minimal value (image 6-57)
 9. Adjust the blue black level on a minimal value

Note: *this minimal value is not necessary, provided that the 2 other colors are not influencing too much the color to be adjusted, in fact the aim is to minimize the effect of the two other colors since there is a risk of reaching too soon the 50% transition due to the contribution of these two other colors signals.*
 10. Adjust the green black level until bright spots appear on the black part of the image
 11. Adjust the Blue black level until bright spots appear on the black part of the image
 12. Adjust the Red black level until bright spots appear on the black part of the image
- The projected image should now be noisy full black

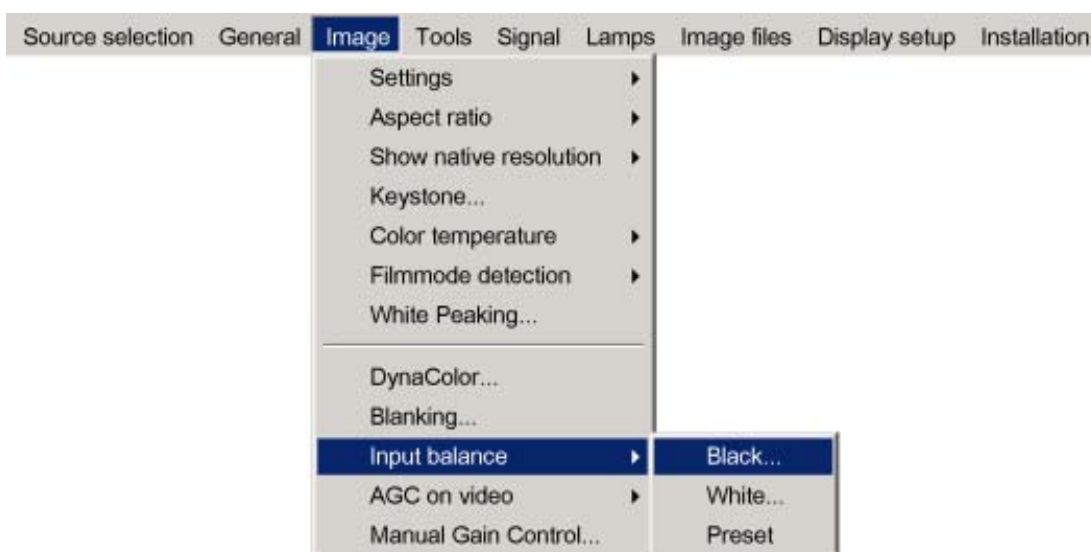

Image 6-56

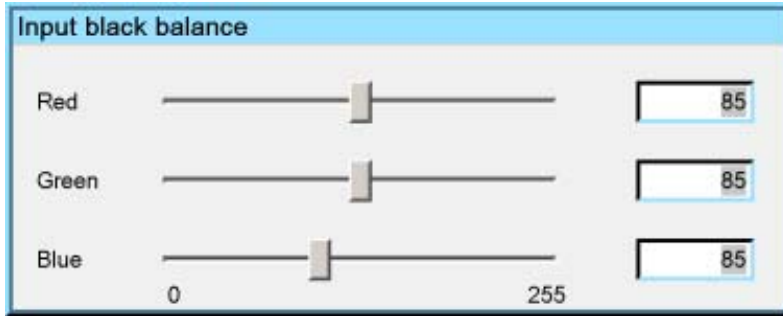

Image 6-57



if one uses a gray scale pattern, the bright spots should appear in the black bar.

Performing White input balance

1. Select a black pattern (or gray scale as alternative)
2. Press **MENU** to activate the Toolbar
3. Press → to select the *Image* item
4. Press ↓ to Pull down the *Image* menu
5. Use ↑ or ↓ to select *Input balance*
6. Press → to pull down the menu
7. Use ↓ or ↑ to select *White balance* (image 6-58)
8. Adjust the red white level (gain) on a minimal value (image 6-59)
9. Adjust the blue white level (gain) on a minimal value

Note: *this minimal value is not necessary, provided that the 2 other colors are not influencing too much the color to be adjusted, in fact the aim is to minimize the effect of the two other colors since there is a risk of reaching too soon the transition (bright spots) due to the contribution of these two other colors signals.*
10. Adjust the Green white level (gain) until bright spots appear on the white part of the image
11. Adjust the Blue white level (gain) until bright spots appear on the white part of the image
12. Adjust the Red white level (gain) until bright spots appear on the white part of the image

The projected image should now be noisy neutral grey.

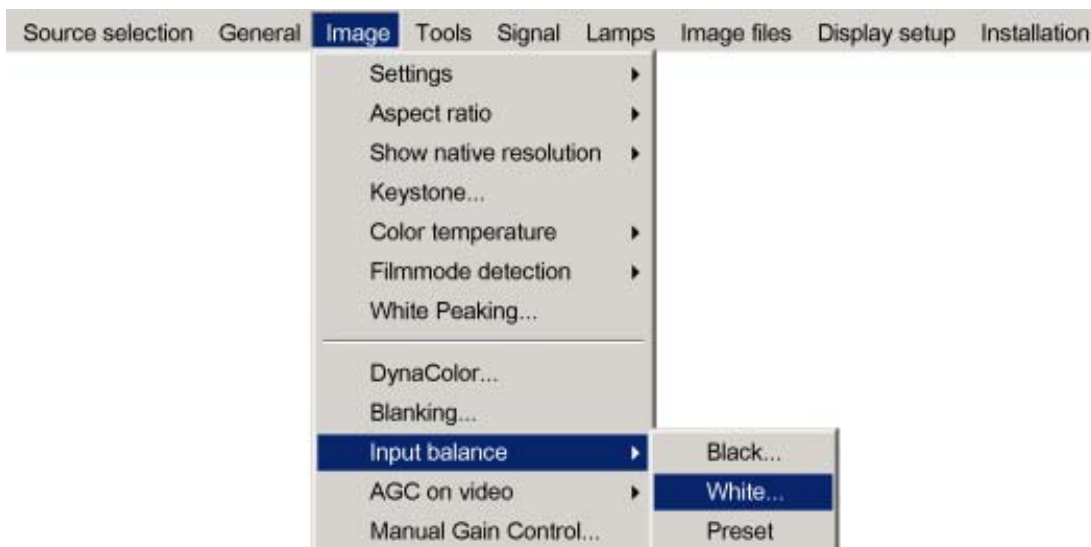

Image 6-58



Image 6-59



if one uses a gray scale pattern, the bright spots should appear in the white bar.



Selecting *Preset* restores the factory input balance setting



The input balance settings are stored in the image file, each source has its own input balance.

6.4.11 AGC on Video



AGC

Automatic Gain Control: allows an automatic amplitude (gain) control of the incoming video signal



AGC is only for Video signals

Enabling/disabling the AGC

1. Press **MENU** to activate the Tool bar
2. Press → to select the *Image* item
3. Press ↓ to Pull down the *Image* menu
4. Use ↑ or ↓ to select *AGC on Video*
5. Press → to pull down the menu
6. Use ↓ or ↑ to enable or disable the AGC
7. Press **ENTER**

A white bullet shows the active setting (image 6-60)

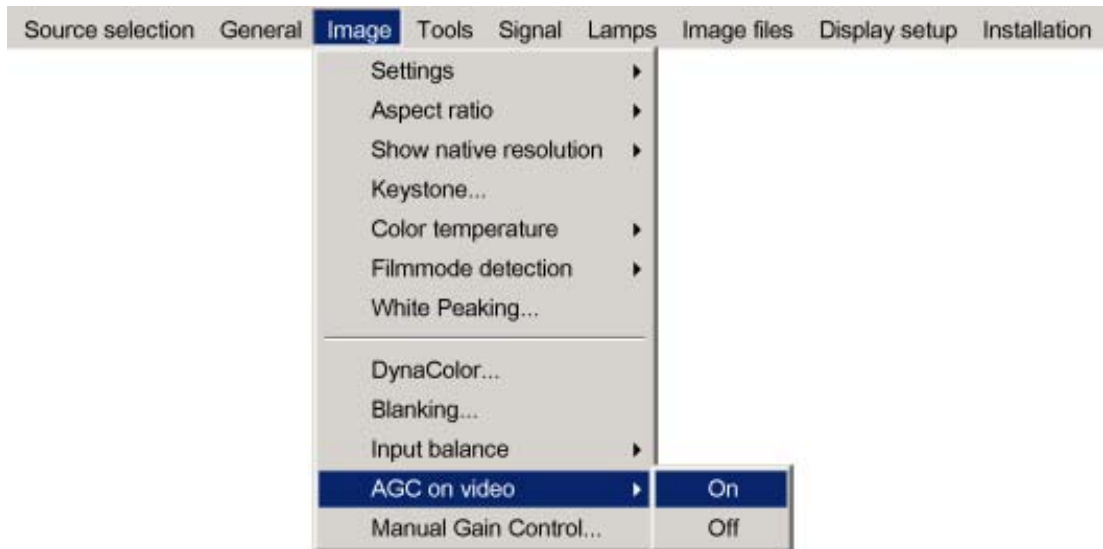

Image 6-60



The AGC can be disturbing in case of Macrovision encoded signals, therefore the AGC can be disabled (OFF) at any time

6.4.12 Manual Gain Control

What can be done ?

Beside the AGC there is the possibility to manually set the gain of the incoming video signal. When the AGC is enabled (ON), the manual setting does not affect the gain, AGC must therefore be disabled. The manual gain control must be done on an external pattern with white areas (grey scale bar pattern)

How to set the Manual Gain Control ?

1. Press **MENU** to activate the Tool bar
2. Press → to select the *Image* item
3. Press ↓ to Pull down the *Image* menu
4. Use ↑ or ↓ to select *Manual Gain Control* (image 6-61)
5. Press **ENTER**
A scroll bar is displayed (image 6-62)
6. Use ← or →, the numeric keys on the remote, or the keypad to change the gain so as to obtain homogeneous white parts in the image.

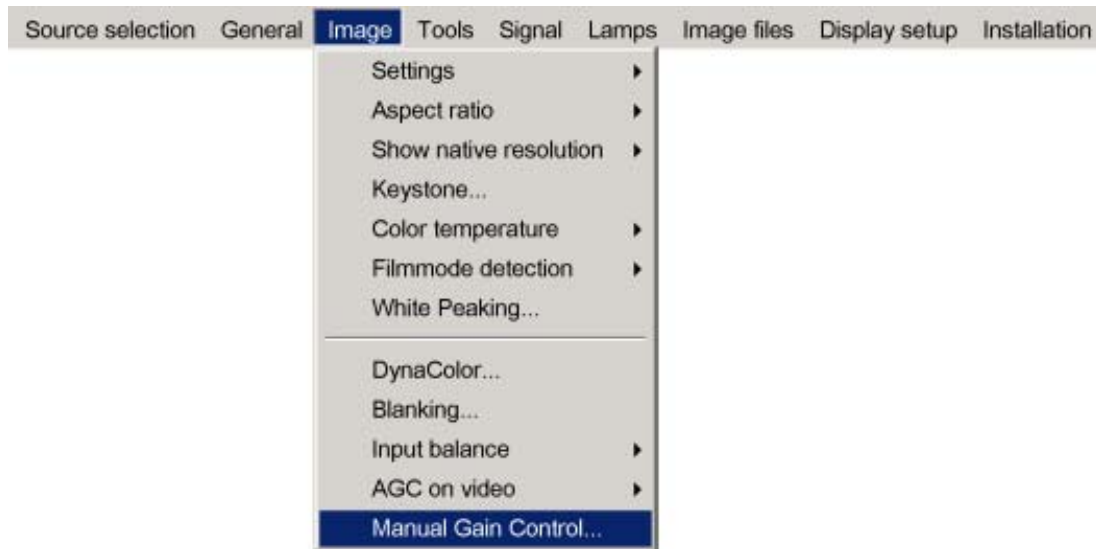

Image 6-61



Image 6-62

6.5 Tools

6.5.1 Introduction to PiP



PiP

PiP stands for "Picture in Picture" and allows to display multiple windows containing each of them an image. The windows may be of the video or data type.

What are the different possibilities within the PiP mode ?

The input section of the IQ projector allows a multitude of combinations of different input signals which may be projected in the 4 windows of the PiP screen.

The PiP mode allows independent settings for each window:

- Image settings : contrast, brightness, tint, color,...
- Vertical and horizontal shift of each window all over the screen
- Resizing of the window
- Digital Zoom
- Linking of (an) audio input(s) to a single or multiple windows

What are the different PiP layouts ?

- Full screen²

The full screen is used to display one of the selected sources.
Browsing through the sources is possible with the **PiP Adjust** button on the remote.

- 2-by-2 raster²

The screen is divided into 4 subscreens containing 2 Video and 2 Data sources.



Image 6-63
PiP: 2by2 layout

- PiP layout 1-3³

These are factory layouts, they can be edited and saved.

- Personal layouts

Beside the 2 fixed layouts and the 3 factory layouts, one can set 5 additional (personal) layouts.

PiP dedicated buttons

- **PiP Adjust** : this button allows to focus on one particular window, this is shown with a white frame surrounding the selected window.
A source identification box is displayed in the right lower corner.

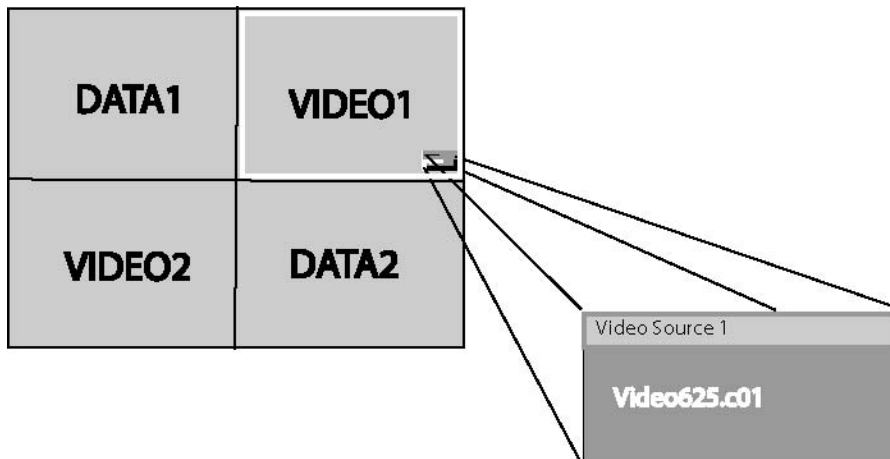

Image 6-64

Pressing the button removes the frame to the next window. This can also be done via *PiP Adjust* in the Tools menu

- **PIP**: this button allows to browse through the different configurations, it has the same function as *PiP select* in the Tools menu.



Since there is only one decoder (second decoder is optional), when in 2by2 configuration, Video1 and Video2 are derived from the same video source.

2. fixed layout
3. factory layouts

6.5.2 PiP select

PiP layouts

The different PiP layouts (configurations) can be selected in the PiP select menu.

How to change the PiP configuration ?

1. Press **MENU** to activate the Tool bar
2. Press → to select the *Tools* item
3. Press ↓ to Pull down the *Tools* menu
4. Use ↑ or ↓ to select *PiP select*
5. Press → to pull down the menu
6. Use ↑ or ↓ to select the desired configuration
7. Press **ENTER**

A white bullet shows the active layout (image 6-65)

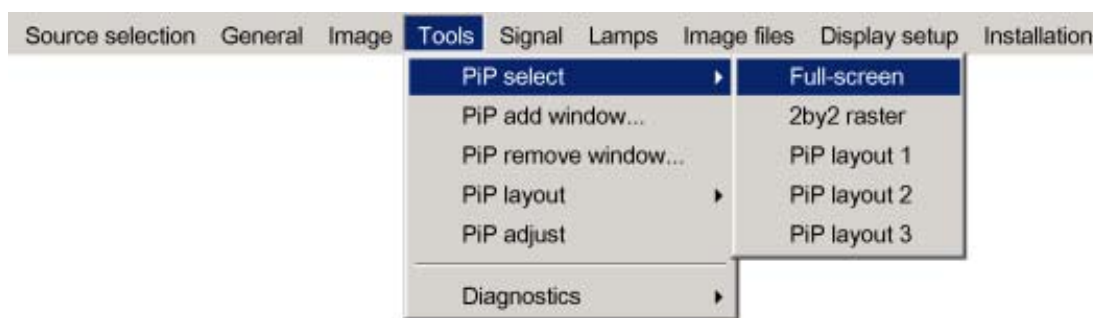

Image 6-65



The PiP configuration can also be selected via the dedicated PiP key on the RCU.

6.5.3 PiP add window

What can be done ?

It is possible to add a window to the existing windows (maximum 4), therefore a source must be selected.

Sources which are already used are non selectable. If, for instance, the PiP layout contains a component video then component video will be non selectable.

Once added, the window may be altered in several ways to meet particular needs:

- repositioning
- re-sizing
- changing the order

How to add a window ?

1. Press **MENU** to activate the Tool bar
2. Press → to select the *Tools* item
3. Press ↓ to Pull down the *Tools* menu
4. Use ↑ or ↓ to select *PiP add window*
5. Press **ENTER**

The source selection menu is displayed (image 6-66)

In the lower part of the screen appears a wizard in 4 steps (image 6-67)

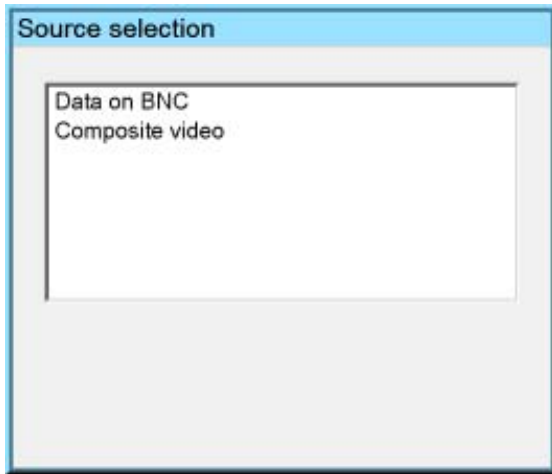

Image 6-66

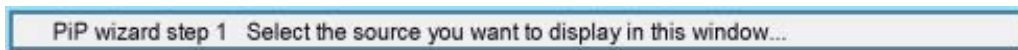

Image 6-67

6.5.4 PiP remove window

How to remove a window ?

1. Press **MENU** to activate the Tool bar
2. Press → to select the *Tools* item
3. Press ↓ to Pull down the *Tools* menu
4. Use ↑ or ↓ to select *PiP remove window*
5. Press **ENTER**

In the lower part of the screen appears a wizard. (image 6-68)

The selected window appears surrounded with a white frame, each hit on **PiP ADJUST** will move the frame along the different windows.



Image 6-68

6.5.5 PiP layout

Overview

- PiP Save
- PiP rename layout
- PiP delete layout

6.5.5.1 PiP Save

What can be done ?

The active layout can be saved or "saved as".

When a new layout is saved it is added to the *PiP select* menu.



A fixed layout can be edited (re-sizing, re-positioning,...) but it can not be saved under its original name.

How to save a layout ?

1. Press **MENU** to activate the Tool bar

2. Press → to select the *Tools* item
3. Press ↓ to Pull down the *Tools* menu
4. Use ↑ or ↓ to select *PiP layout*
5. Press → to pull down the menu
6. Use ↑ or ↓ to select *PiP save* or *save as*
7. Press **ENTER**

If *save as* has been selected, a dialog box is displayed (image 6-69)

Use ← or →, the numeric keys on the remote, or the keypad to enter the name and exit with **BACK** or **MENU**.

If *save* has been selected, a message box is displayed (image 6-70)

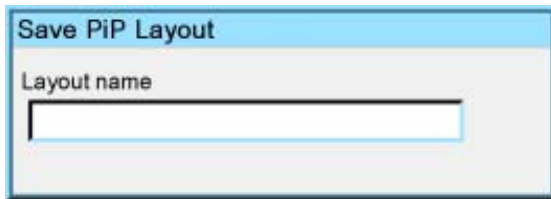

Image 6-69

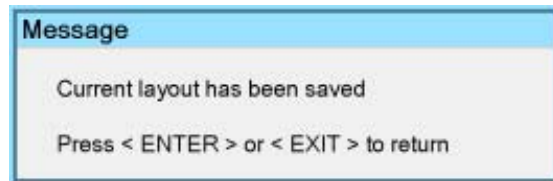

Image 6-70

6.5.5.2 PiP rename layout

What can be done ?

The non fixed layouts (factory and personal layouts) can be renamed .

The maximal length of the name is 12 characters.



A fixed layout can not be renamed

How to rename a layout ?

1. Press **MENU** to activate the Tool bar
2. Press → to select the *Tools* item
3. Press ↓ to Pull down the *Tools* menu
4. Use ↑ or ↓ to select *PiP layout*
5. Press → to pull down the menu
6. Use ↑ or ↓ to select *Rename*
7. Press **ENTER**
8. Use ↑ or ↓ to select the layout to be renamed
9. Press **ENTER**

A dialog box is displayed (image 6-71)

A dialog box is displayed (image 6-72)

Use ← or →, the numeric keys on the remote, or the keypad to enter the name and exit with **BACK** or **MENU**.



Image 6-71

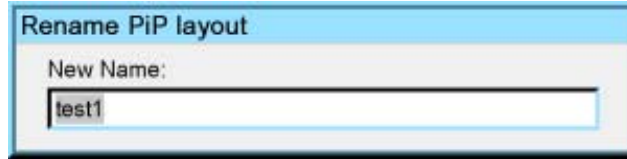

Image 6-72

6.5.5.3 PiP delete layout

What can be done ?

The non fixed layouts (factory and personal layouts) can be deleted.



The fixed layouts and the active layout can not be deleted

How to delete a layout ?

1. Press **MENU** to activate the Tool bar
2. Press → to select the *Tools* item
3. Press ↓ to Pull down the *Tools* menu
4. Use ↑ or ↓ to select *PiP layout*
5. Press → to pull down the menu
6. Use ↑ or ↓ to select *Delete*
7. Press **ENTER**

A dialog box is displayed (image 6-73)

8. Use ↑ or ↓ to select the layout to be renamed
9. Press **ENTER**

The layout is deleted and disappears from the dialog box



Image 6-73

6.5.6 PiP Adjust

What can be done ?

PiP adjust allows to browse through the windows in the active layout, a white frame indicates the window which has the focus. This way, independent settings (picture settings, ...) are possible for each window.



This can also be done by using the dedicated PiP Adjust key on the RCU

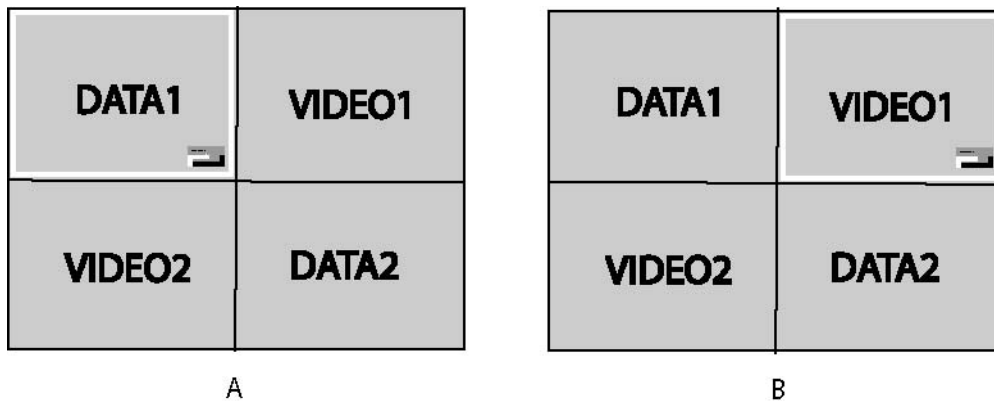

Image 6-74
PiP adjust in case of 2by2 layout

- A Data1 window has the focus, new settings will only affect Data1 window
- B Video1 window has the focus, new settings will only affect Video1 window

PiP adjust

1. Press **MENU** to activate the Toolbar
2. Press **→** to select the *Tools* item
3. Press **↓** to Pull down the *Tools* menu
4. Use **↑** or **↓** to select *PiP Adjust*
5. Press **ENTER**
The menu disappears.
The focus moves to the next window when pressing **ENTER** (clockwise rotation)
If you press **BACK** or if you wait 5 seconds the menu is displayed.



When using the PiP adjust key on the RCU the corresponding source box is displayed in the bottom right corner.

How to adjust a window in the layout ?

1. Use the PiP Adjust key or function in the menu to choose the window to be adjusted
2. Press **ENTER**
A wizard bar is displayed in the bottom of the screen
Follow the procedure.

6.5.7 Color keying

Principle of color keying

Take e.g. two image. One taken on a full color background and the other a normal image. The full color background will be replaced by the second image via the principle of color keying.



Image 6-75
Zebra on a single color



Image 6-76
Full color image



Image 6-77
Result image after color keying



The color keying function is only relevant when in presence of the Pro version, although present in the standard version.

6.5.8 Diagnostics

Diagnostics

1. See the Troubleshoot section in the appendix

6.6 Signal Menu

Overview

- Switching mode
- Background

6.6.1 Switching mode

Switching from one source to another

To minimize undesired effects when switching from one source to another, one can use the Seamless switching mode, beside Seamless switching there is a wide choice of several effects which render the source switching transitions more enjoyable.

How to select a switching mode ?

1. Press **MENU** to activate the Tool bar
2. Press → to select the *Signal* item
3. Press ↓ to Pull down the *Signal* menu
4. Use ↑ or ↓ to select *Switching mode*
5. Press → to pull down the menu
6. Use ↑ or ↓ to select the desired switching mode (image 6-78)
7. Press **ENTER**

A white bullet shows the active effect.

The next source switching will be done using the selected effect

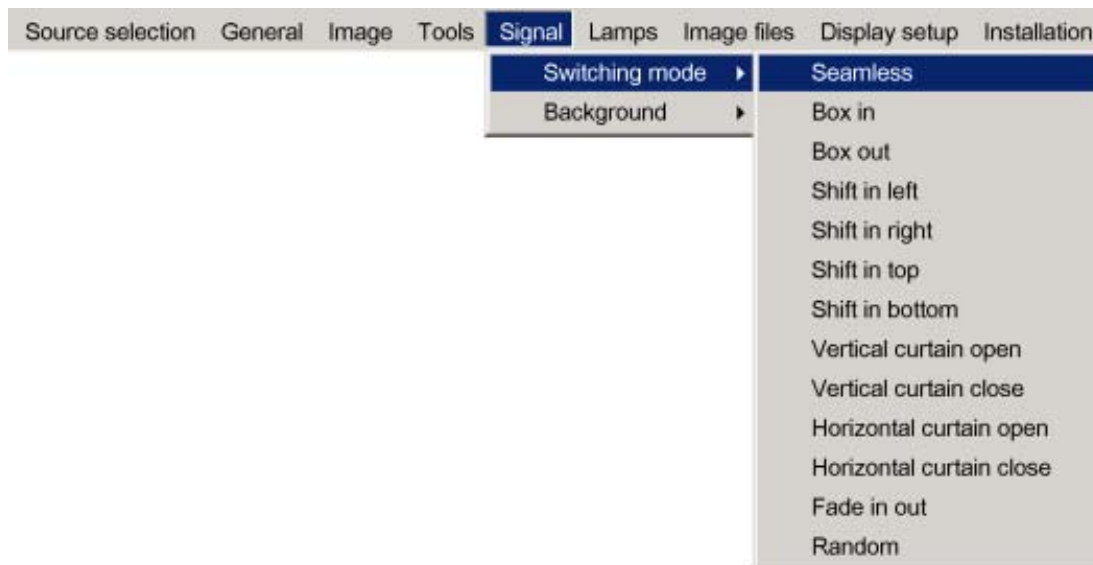

Image 6-78



The *Random* mode will select a new switching mode at each source switching i.e. there will never be 2 successive source switchings with the same effect.

The *Seamless* switching mode is not used in the *Random* mode.



The switching effects are only possible in the full screen mode



When the source switching mode is the fade in/out mode, the audio (when available) switching will also be done using a fade in/out effect.

6.6.2 Background

Purpose

If there is no signal connected to the projector, the background will be a logo, a black or a blue screen depending on the *background* settings.

How to change the background ?

1. Press **MENU** to activate the Toolbar
2. Press → to select the *Signal* item
3. Press ↓ to Pull down the *Signal* menu
4. Use ↑ or ↓ to select *Background*
5. Press → to pull down the menu
6. Use ↑ or ↓ to select the desired background (image 6-79)
7. Press **ENTER**

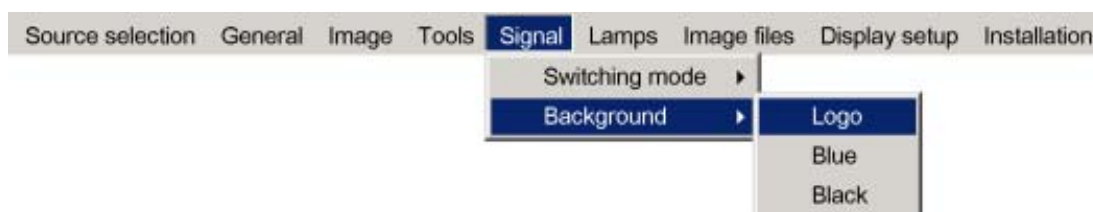

Image 6-79



The logo display is only possible in the full screen mode, a logo can thus not be displayed (rescaled) in a window in the PiP mode.



When there is no signal connected, the projector will also start its standby timer countdown (if enabled) and shuts down after the predetermined time.

6.7 Lamp management

6.7.1 Runtimes

How to display the lamp runtimes ?

1. Press **MENU** to activate the Toolbar
2. Press → to select the *Lamp* item
3. Press ↓ to Pull down the *Lamp* menu
4. Use ↑ or ↓ to select *Runtimes* (image 6-80)
5. Press **ENTER**

A textbox is displayed (image 6-81)

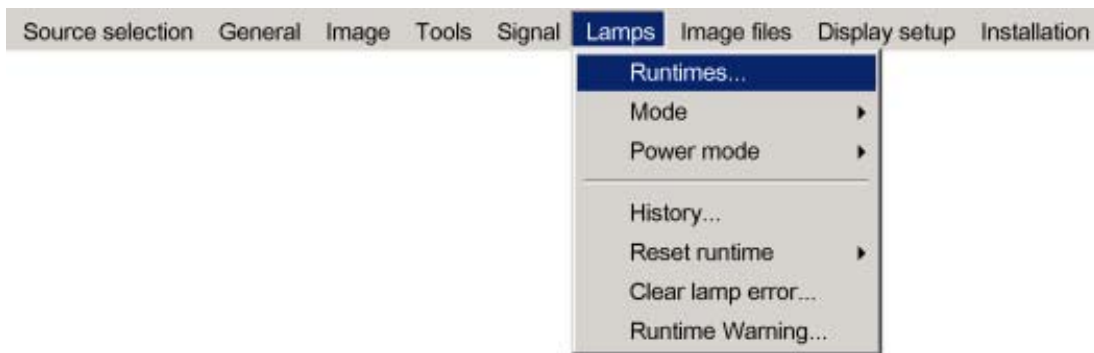

Image 6-80

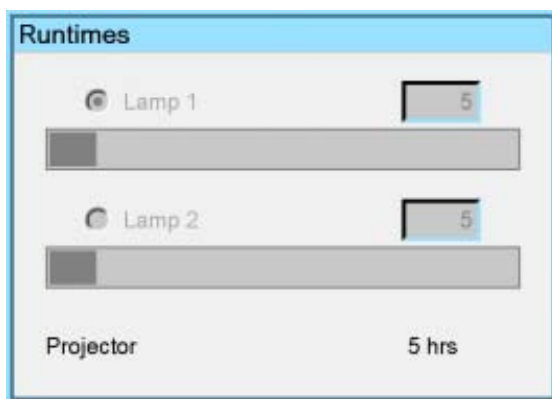

Image 6-81

6.7.2 Mode

What are the different lamp modes ?

Single mode

The projector will always switch to the lamp with the shortest runtime when the difference between the runtimes of lamp1 and lamp 2 reaches **100 hours**, switching from one lamp to another happens only at switching on of the projector and not during operation.

When the lamp fails or reaches its maximum runtime the projector switches automatically to the other lamp without interrupting the projection. The failure is logged and the lamp will never be initialized in the future.

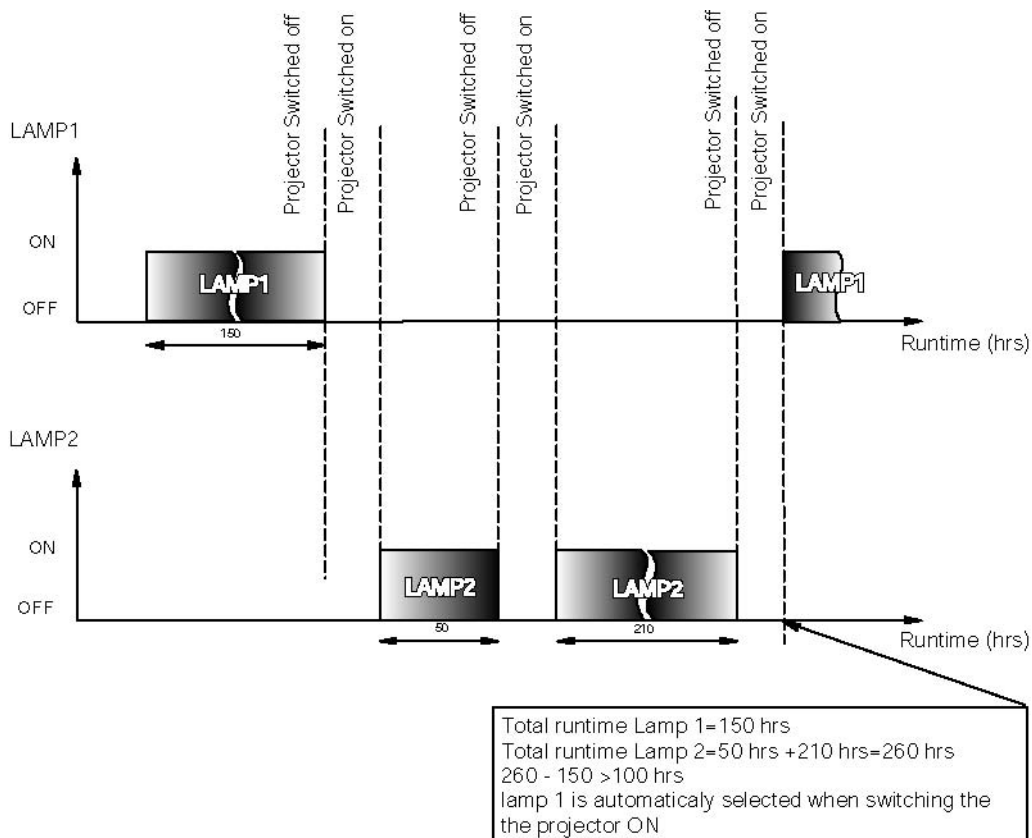

Image 6-82
 Single mode operation: switching principle

Dual mode

Both lamps are working.

When one lamp fails, the projector continues the projection using the remaining lamp.

How to select the lamp mode ?

1. Press **MENU** to activate the Toolbar
2. Press **→** to select the *Lamp* item
3. Press **↓** to Pull down the *Lamp* menu
4. Use **↑** or **↓** to select *Mode*
5. Press **→** to pull down the menu
6. Use **↑** or **↓** to select the desired background (image 6-83)
7. Press **ENTER**

A bullet shows the active mode.



Image 6-83



When switching from the dual mode to the single mode the lamp with the longest runtime is switched off.
If the runtimes are equal (if the projector has always been operated in dual mode) then lamp1 is switched out.



When switching to single mode, returning to the dual mode will not be possible in the first 60 seconds, *Dual* in the menu is greyed out and LED1 is flickering, thereby preventing hot restrike which may damage the lamp.

6.7.3 History

How to view the history ?

1. Press **MENU** to activate the Tool bar
2. Press → to select the *Lamp* item
3. Press ↓ to Pull down the *Lamp* menu
4. Use ↑ or ↓ to select *History* (image 6-84)
5. Press **ENTER**
A textbox is displayed (image 6-85)



Image 6-84

Lamp history		
Lamp	Serial no.	Runtime
L1	0001230	900
L2	0001222	900

Current lamps		
Lamp	Serial no.	Runtime
L1	0001240	900
L2	0001242	900

Image 6-85

6.7.4 Reset runtime

When to reset the lamp runtime ?

The lamp runtime should only be reset when placing a new lamp.



WARNING: Lamp runtime reset as well as the lamp replacement can only be done by a Barco authorized technician.

How to reset the lamp runtime in the iQ/iD ?

1. Press **MENU** to activate the Tool bar
2. Press → to select the *Lamp* item
3. Press ↓ to Pull down the *Lamp* menu
4. Use ↑ or ↓ to select *Reset runtime*
5. Press → to pull down the menu
6. Use ↑ or ↓ to select the lamp to be reset (image 6-86)
7. Press **ENTER**
A dialog box is displayed (image 6-87)
8. Use ← or →, the numeric keys on the remote, or the keypad to change the serial number of the lamp (serial number 0000000 will not be accepted).

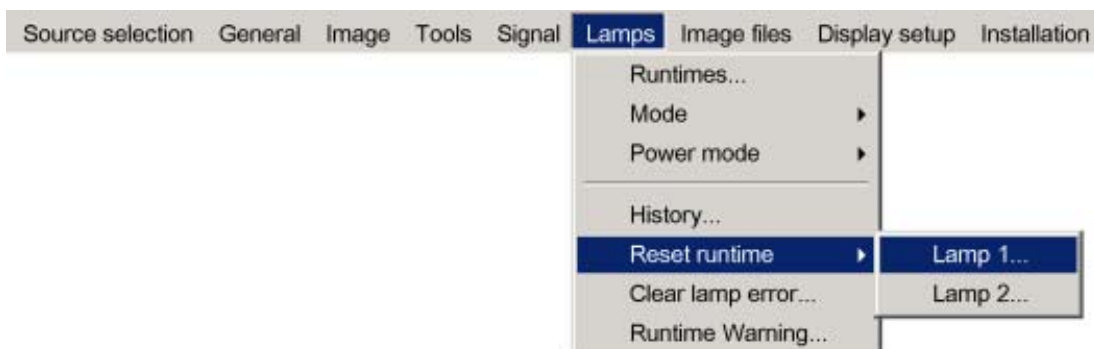

Image 6-86



Image 6-87



WARNING: Lamp runtime reset as well as the lamp replacement can only be done by a Barco authorized technician.

How to reset the lamp runtime in the SIM5Plus?

1. Press **MENU** to activate the Tool bar
2. Press **→** to select the *Lamp* item
3. Press **↓** to Pull down the *Lamp* menu
4. Use **↑** or **↓** to select *Reset runtime*
5. Press **→** to pull down the menu
6. Use **↑** or **↓** to select the lamp to be reset
7. Press **ENTER**

A dialog box is displayed (image 6-88)

8. Use **←** or **→**, the numeric keys on the remote, or the keypad to change the serial number of the lamp (serial number 0000000 will not be accepted).



Image 6-88



WARNING: Lamp runtime reset as well as the lamp replacement can only be done by a Barco authorized technician.

6.7.5 Runtime warning

What can be done ?

When the lamp has reached a certain predetermined runtime , a warning message will be displayed on the screen. The lamp runtime warning can be set in a range from 30 to 200 hours. The runtime warning is displayed by default at 30 hours before end of lamp lifetime.

How to set the lamp runtime warning?

1. Press **MENU** to activate the Toolbar
2. Press → to select the *Lamp* item
3. Press ↓ to Pull down the *Lamp* menu
4. Use ↑ or ↓ to select *Runtime warning* (image 6-89)
5. Press **ENTER**
A dialogbox is displayed (image 6-90)
6. Use ←or →, the numeric keys on the remote, or the keypad to change the runtime warning setting.

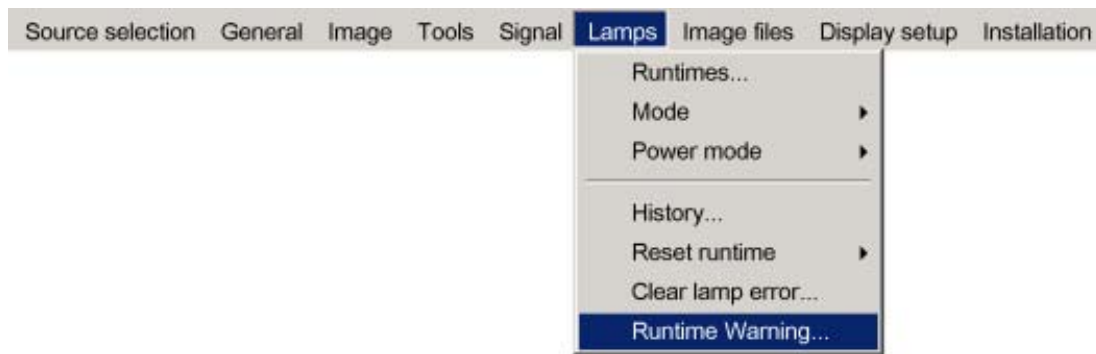

Image 6-89

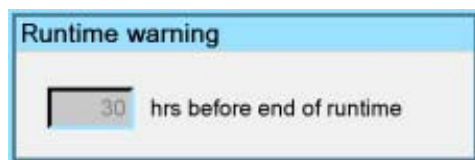

Image 6-90



WARNING: Lamp runtime reset as well as the lamp replacement can only be done by a Barco authorized technician.

6.8 Image files menu

Overview

- Load file
- Auto Image
- Edit file
- Rename file
- Copy
- Delete
- Forced file load

6.8.1 Load file

How to load a file ?

1. Press **MENU** to activate the Tool bar
2. Press → to select the *Image files* item
3. Press ↓ to Pull down the *Image files* menu
4. Use ↑ or ↓ to select *Load* (image 6-91)
5. Press **ENTER**
A dialog box is displayed (image 6-92)

6. Advanced

6. Use ↑ or ↓ to select the desired file

Tip: For more info about the available image files and the specifications, see "Standard Image Files", page 157

7. Press **ENTER**

The file is loaded and the image is adapted.

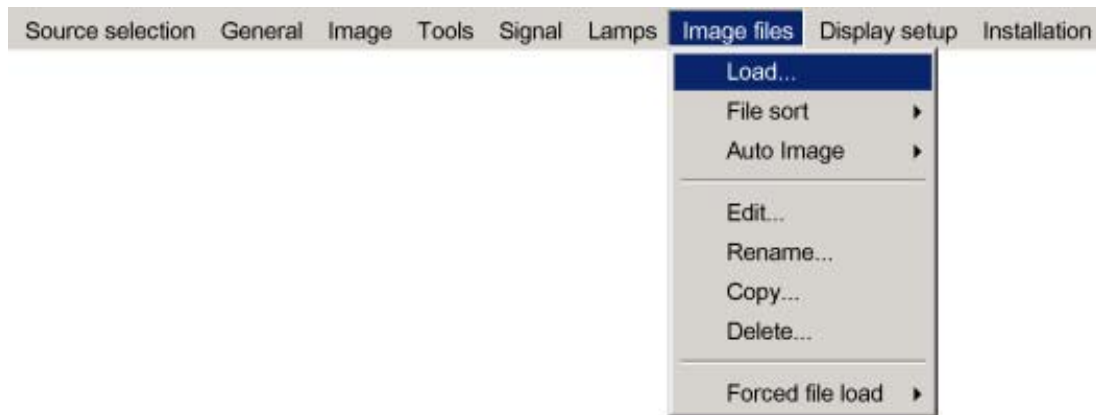

Image 6-91

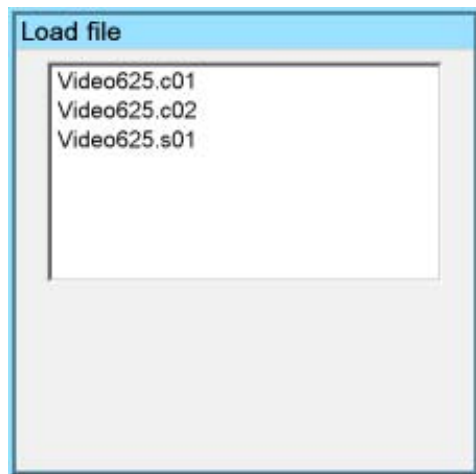

Image 6-92



In PiP mode, the files which may be loaded will be of the data type if the active window is a data window, or they will be of the video type if the active window is a video window.

What to do if the image is not perfect ?

If the displayed image is not correct after AutoImage or after selecting the best fitting file, go to the Edit menu, select the active file and change the settings.

6.8.2 Auto Image

What can be done ?

Auto Image creates the best suited image file for the connected source.

It calculates/measures several source parameters :

- Total pixels per line
- Start pixel
- Phase
- Contrast/Brightness levels



Auto Image works only for data images.

The measure of the total number of pixels per line can be done through 2 methods

- Limited scan: a windowing is used to allow fast tracking.
The operation takes about 20 seconds (depending on file)
- Full scan: tracking is done over the full range.
The operation takes about 1.5 minutes (depending on file)

How to launch Auto Image?

1. Press **MENU** to activate the Tool bar
2. Press → to select the *Image files* item
3. Press ↓ to Pull down the *Image files* menu
4. Use ↑ or ↓ to select *Auto Image*
5. Press → to open the menu
6. Use ↑ or ↓ to select the desired file scan method (image 6-93)
7. Press **ENTER**
A text box showing a progress bar is displayed. (image 6-94)
Tip: Press the **Cancel** button to cancel the operation.

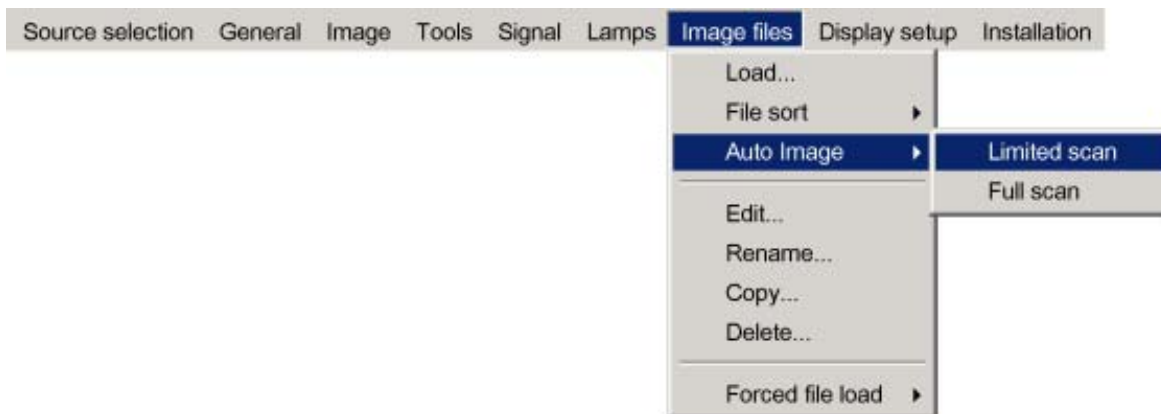

Image 6-93

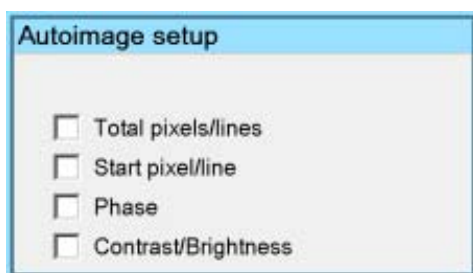

Image 6-94



The Auto Image setup in the *Display setup* menu affect only Auto Image if it is launched via the RCU key or at automatic file creation.

Launching Autolmage via the menu involves complete checking of all parameters.



Auto Image can also be launched via the RCU with the dedicated Autolmage key.

6.8.3 Edit file

What can be done with the Edit file menu ?

The Edit file menu makes it possible to change the settings of the file according to the real settings of the connected source. Consult the source specifications before entering the data.

How to edit a file ?

1. Press **MENU** to activate the Tool bar
2. Press **→** to select the *Image files* item
3. Press **↓** to Pull down the *Image files* menu
4. Use **↑** or **↓** to select *Edit* (image 6-95)
5. Press **ENTER**
A dialog box is displayed
6. Use **↑** or **↓** to select the desired file
Note: *If in PiP mode the cursor is placed by default on the active file which has the focus.*
7. Press **ENTER**
A dialog box is displayed (image 6-96)
8. Press **ENTER**
A dialog box is displayed (image 6-97)
9. Use **←** or **→**, the numeric keys on the remote, or the keypad to edit and change the values, confirm with **ENTER**
Note: *greyed out fields can not be updated (total pixels)*



Image 6-95

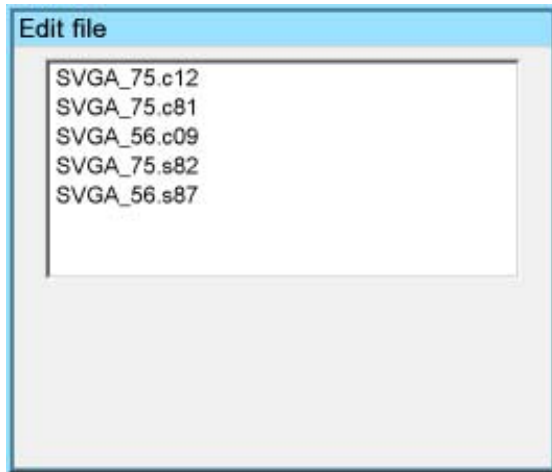

Image 6-96

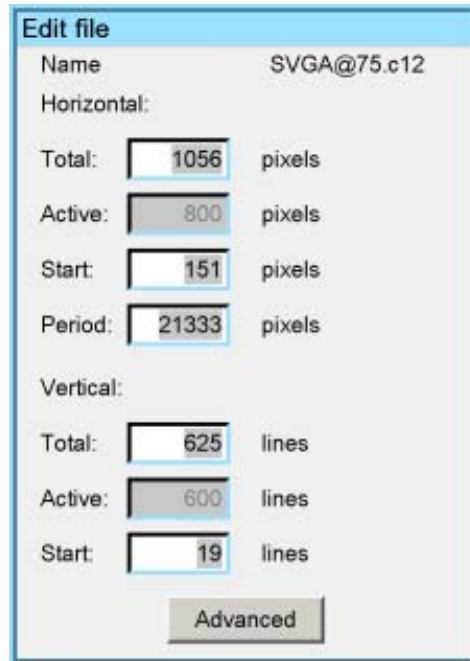

Image 6-97

Which items can be adjusted ?

The following items can be adjusted :

- Active horizontal pixels
- Horizontal start in pixels
- Horizontal period in ns
- Active vertical lines
- Vertical start in lines

Advanced video settings

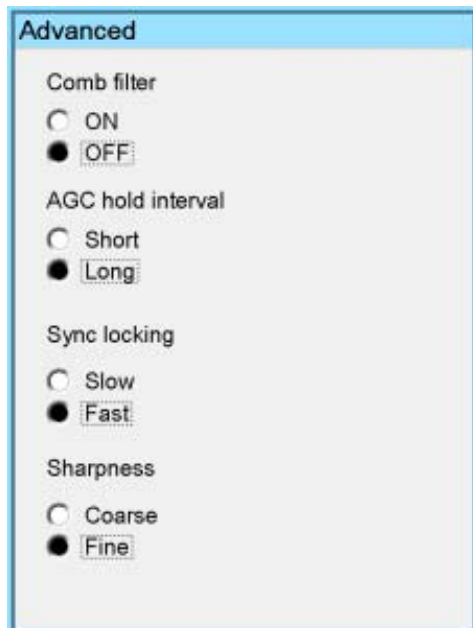

Image 6-98

The **advanced** button enables the advanced settings for a video source.

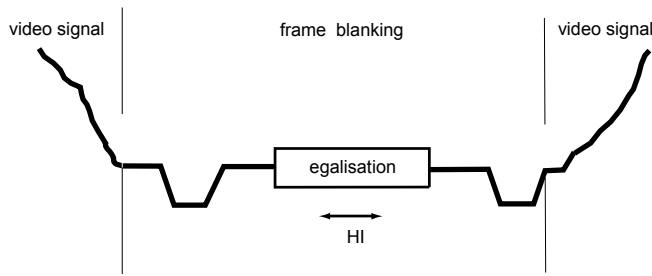

Image 6-99
HI AGC Hold interval

The **Comb filter** is by default enabled.

The **AGC hold interval** is the time interval in which the AGC is inhibited (AGC hold = no update in video amplitude measurement), the advanced parameter allows to choose a short or long hold interval.

A long AGC hold interval eliminates Macrovision® disturbances since the AGC is hold during a long interval, thus reducing the probability to encounter a Macrovision® pulse.

The **sync locking setting** is recommended for poor video signals (ex: poor TV signals).

Sharpness adjustment can be chosen to be coarse or fine.



It is recommended to use the default values.

Advanced Data settings

The **advanced** button enables the advanced settings for a data source.

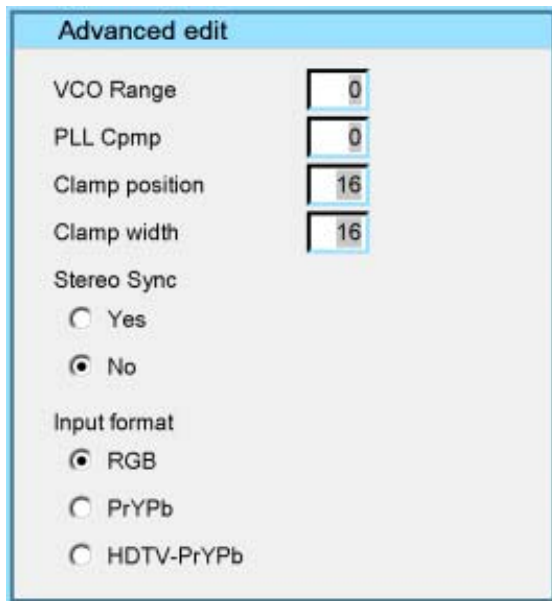

Image 6-100

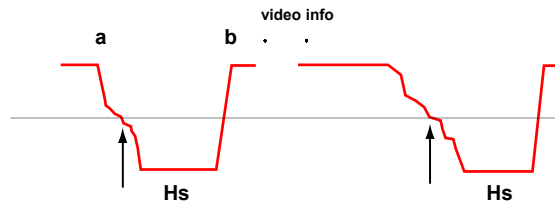

Image 6-101
Hs horizontal sync pulse
a active low
b active high

The **VCO range** setting determines the frequency range of the VCO (Voltage Controlled Oscillator).

The **Cpmp** (Charge pump current) sets the low pass filter current.

Both VCO range & Cpmp are set by the image file, changing these settings is only indicated in for special purposes.

The **horizontal sync polarity** setting can be useful in case of a bad shaped edge, one can choose between the leading (active low) or trailing (active high) edge.

The input format settings are used to "tell more" about the signals connected on the BNC's, it completes the information in the source selection menu.

- RGB is selected by default and means that an RGB signal is connected to the BNC's

- PR/Y/PB must be selected whenever:

- a progressive signal (32 kHz frequency video signal) is connected to the BNC's (select the source with *Data on BNC's* in the Source selection menu).
- one wants (in PiP mode) to visualize the component video signal in a Data window hereby adding a video image in the PiP layout.

-HDTV-PR/Y/PB for high definition component video signals.



It is recommended to use the default values.

6.8.4 Rename file

How to rename a file ?

1. Press **MENU** to activate the Tool bar
2. Press **→** to select the *Image files* item
3. Press **↓** to Pull down the *Image files* menu
4. Use **↑** or **↓** to select *Rename* (image 6-102)
5. Press **ENTER**
A dialog box is displayed (image 6-103)
6. Use **↑** or **↓** to select the desired file
7. Press **ENTER**

A text box is displayed (image 6-104)

Use **←** or **→**, **↓** or **↑** the numeric keys on the remote, or the keypad to edit and change the values, confirm with **ENTER**.



Image 6-102

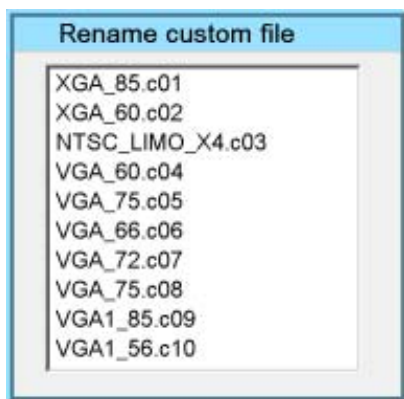

Image 6-103

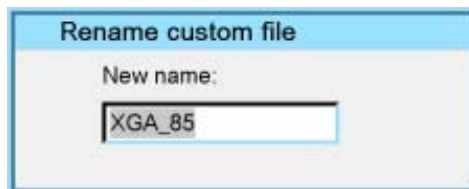

Image 6-104

6.8.5 Copy

How to copy a file ?

1. Press **MENU** to activate the Tool bar
2. Press → to select the *Image files* item
3. Press ↓ to Pull down the *Image files* menu
4. Use ↑ or ↓ to select *copy* (image 6-105)
5. Press **ENTER**
A dialogbox is displayed (image 6-106)
6. Use ↑ or ↓ to select the desired file
7. Press **ENTER**
A text box is displayed (image 6-107)
Use ← or →, ↓ or ↑ on the remote, or the keypad to enter the new name, confirm with **ENTER**.

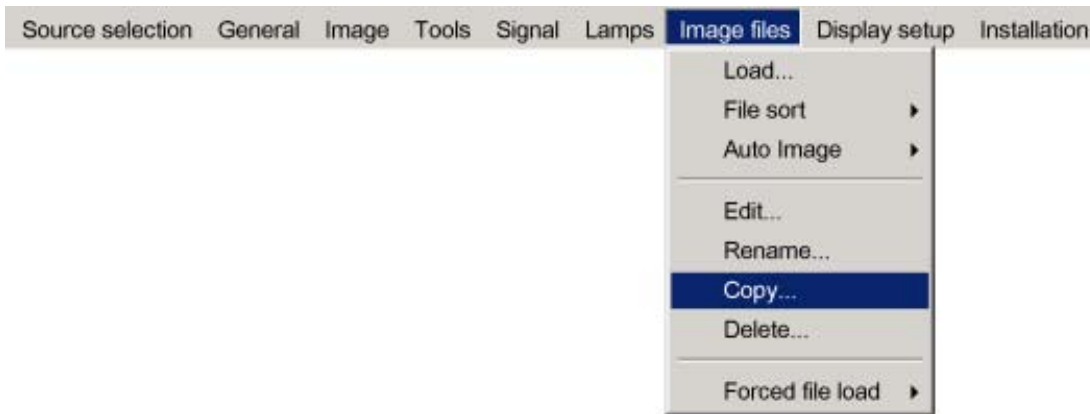

Image 6-105

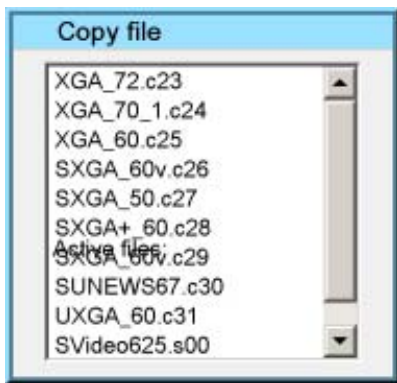

Image 6-106



Image 6-107



If the AutoImage function does not succeed in finding a file and no file is loaded (load list is empty), which means that the source is not displayed, then use the *copy* function: Copy a standard file (.std) which is not too different of the source to display, then edit this file to get the best image.

6.8.6 Delete

How to delete a file ?

1. Press **MENU** to activate the Tool bar
2. Press → to select the *Image files* item
3. Press ↓ to Pull down the *Image files* menu
4. Use ↑ or ↓ to select *delete* (image 6-108)
5. Press **ENTER**
A dialog box is displayed (image 6-109)

6. Use ↑ or ↓ to select the desired file

7. Press **ENTER**

The selected file is deleted and is removed from the list



Image 6-108



Image 6-109

6.8.7 Forced file load

What can be done ?

Forced file load allows to force or lock one particular custom file to be loaded for one particular input. This way one can guarantee that the same desired file is always used for a particular source.

For each layer (layer 1, layer 2, layer 3) we can enable or disable the forced file load. The specification for the file to be selected for each input on that layer is done via RS232.



see the **RS232 User Guide** for more information on the **Forced file load** command to be sent.

How to set a file to be loaded ?

1. Press **MENU** to activate the Tool bar
2. Press → to select the *Image files* item
3. Press ↓ to Pull down the *Image files* menu
4. Use ↑ or ↓ to select *Forced file load*
5. Press → to open the menu (image 6-110)
6. Use ↑ or ↓ to select the desired layer
7. Press **ENTER**

Forced file load is activated for this layer (this is shown with a bullet)

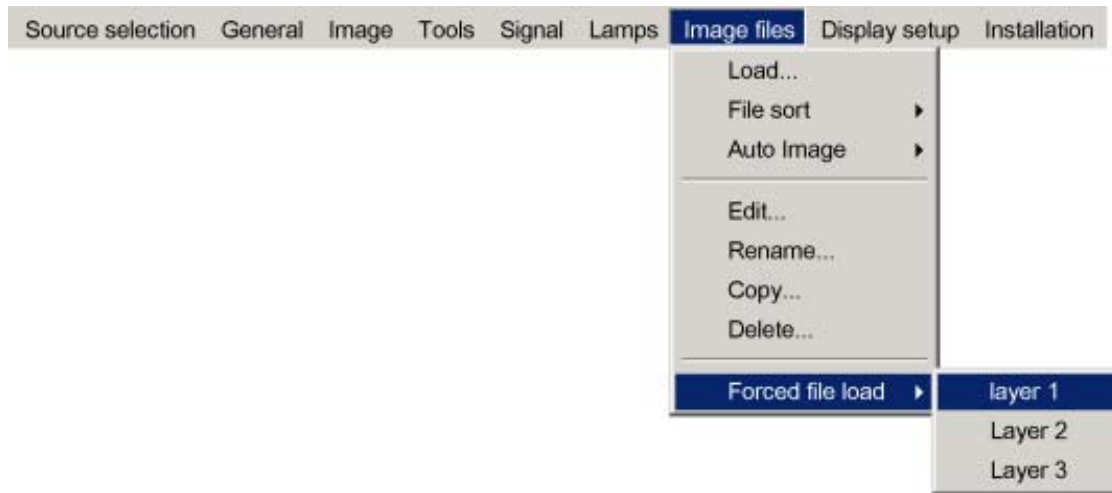

Image 6-110

6.9 Display Setup

Overview

- Full screen representation
- Startup screen
- Textbox
- Take screenshot
- Menu bar position
- Status bar position
- Sliderbox position
- AutoImage Setup
- Blanking
- Soft Edge

6.9.1 Full screen representation

Purpose of the Full screen representation

The *Full screen representation* function forces to use the complete native resolution of the LCD panels independently of the native resolution of the source.

Note that the full screen representation does not preserve the aspect ratio of the source, i.e. when the aspect ratio of the active image is not the same as the projector (in this case 1920/1080 or 1.77:1), the image will end to be distorted (stretched or shrunk).

How to enable/disable the full screen representation ?

1. Press **MENU** to activate the Tool bar
2. Press → to select the *Display setup* item
3. Press ↓ to Pull down the Display setup menu
4. Use ↑ or ↓ to select *Full screen representation*
5. Press → to pull down the menu
6. Use ↓ or ↑ to select ON or OFF
7. Press **ENTER**



The full screen representation will not guarantee the best image quality, therefore the *Show native resolution* has to be selected.

The *show native resolution* function on the other hand forces to use the native resolution of the source.

The *Full screen representation* function overrules the *show native resolution* function.



The aspect ratio setting is greyed out when enabling the full screen representation.

6.9.2 Startup screen

What can be done ?

When the startup screen is enabled, the identification screen is displayed for a few seconds at startup. This startup screen can also be disabled.

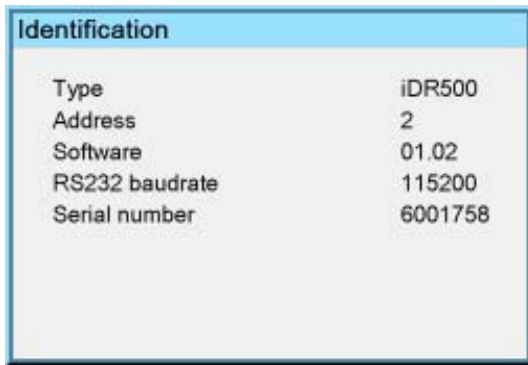

Image 6-111

How to enable/disable the Startup screen?

1. Press **MENU** to activate the Tool bar
2. Press → to select the *Display setup* item
3. Press ↓ to Pull down the *Display setup* menu
4. Use ↑ or ↓ to select *Startup screen*
5. Press → to pull down the menu
6. Use ↓ or ↑ to select the ON or OFF
7. Press **ENTER**

6.9.3 Textbox

What can be done ?

The textbox function allows to display or not the different sliderboxes used for instance for picture settings (contrast,...), it also affects the source information windows (displayed in the right lower corner of the screen).

How to enable/disable the Textbox ?

1. Press **MENU** to activate the Toolbar
2. Press → to select the *Display setup* item
3. Press ↓ to Pull down the *Display setup* menu
4. Use ↑ or ↓ to select *Textbox*
5. Press → to pull down the menu
6. Use ↓ or ↑ to enable/disable the textbox
7. Press **ENTER**

6.9.4 Take screenshot

What can be done ?

A screenshot can be taken from an active projected image. This screenshot is then saved in a 4 MB RAM and can be used as background.

Each new screenshot erases the previous logo therefore a warning message is displayed asking the user to confirm.

How to take a screenshot ?

1. Press **MENU** to activate the Tool bar
2. Press → to select the *Display setup* item
3. Press ↓ to Pull down the *Display setup* menu
4. Use ↑ or ↓ to select *Take screenshot*
5. Press **ENTER**

A dialog box is displayed. Press **yes** to confirm. (image 6-112)

A text box shows the evolution of the operation. (image 6-113, image 6-114)



Image 6-112

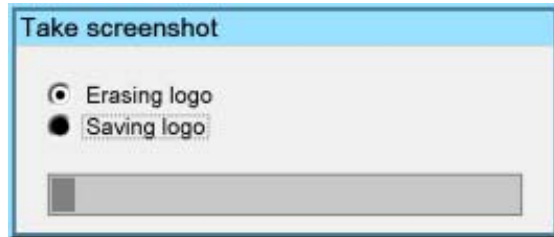

Image 6-113

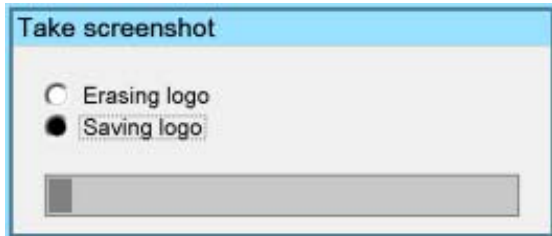

Image 6-114

6.9.5 Menu bar position

What can be done ?

The menu toolbar can be centered vertically, the range being from top of the screen to the middle of the screen. This can be useful in applications where the top image content is not displayed.

How to center the menu ?

1. Press **MENU** to activate the Toolbar
2. Press → to select the *Display setup* item
3. Press ↓ to Pull down the *Display setup* menu
4. Use ↑ or ↓ to select *Menu bar position menu*
5. Press **ENTER**
6. Use ↑ or ↓ to position the menu toolbar

6.9.6 Status bar position

What can be done ?

The status bar (wizard menu) can be centered vertically, the range being from bottom of the screen to the middle of the screen. This can be useful in applications where the bottom image content is not displayed.

How to center the menu ?

1. Press **MENU** to activate the Toolbar
2. Press → to select the *Display setup* item
3. Press ↓ to Pull down the *Display setup* menu
4. Use ↑ or ↓ to select *Status bar position*
5. Press **ENTER**
6. Use ↑ or ↓ to position the status bar

6.9.7 Sliderbox position

What can be done ?

The sliderbox can be displayed anywhere on the screen, the position can be set in this menu.

How to reposition the sliderbox?

1. Press **MENU** to activate the Tool bar
2. Press → to select the *Display setup* item
3. Press ↓ to Pull down the *Display setup* menu
4. Use ↑ or ↓ to select *Sliderbox position*
5. Press **ENTER**

A sliderbox is displayed. Use the 4 arrow keys to drag the box to the desired position. (image 6-115)

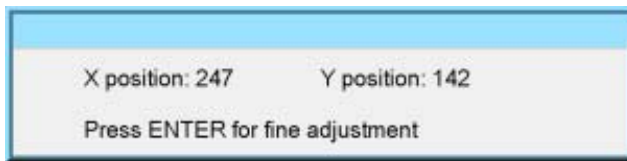

Image 6-115



There is a coarse and a fine adjustment of the position, use **ENTER** (when sliderbox is displayed) to switch between the two.

6.9.8 Autolmage Setup

What can be done ?

Autoimage allows to detect automatically the characteristics of the source (total pixels per line,...) and uses this information to adapt the image to the LCD panels.

Autoimage can adapt the image based on following data :

- Total pixels per line
- Start pixel
- Phase
- Contrast/brightness levels



Autoimage works only for data signals.

How to set up Autolmage?

1. Press **MENU** to activate the Tool bar
2. Press → to select the *Display setup* item
3. Press ↓ to Pull down the *Display setup* menu
4. Use ↑ or ↓ to select *Autolmage setup*
5. Press **ENTER**

A dialog box is displayed.

(image 6-116)

6. Use the arrow keys to select the desired item and press **ENTER** to activate or disactivate the item.

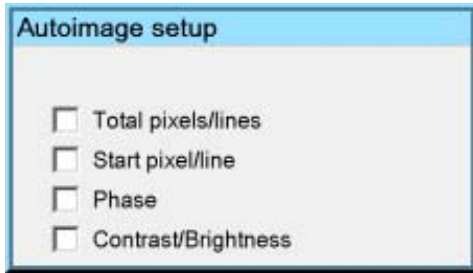

Image 6-116

How to perform AutoImage ?

1. Press **AutoImage** on the RCU

A textbox showing a progress bar is displayed.



During the AUTOIMAGE measuring process the data source disappears temporarily (logo is displayed if background is set to logo)

6.9.9 Blanking

What can be done ?

The image can be blanked in several ways :

- Top blanking
- Bottom blanking
- Left blanking
- Right blanking

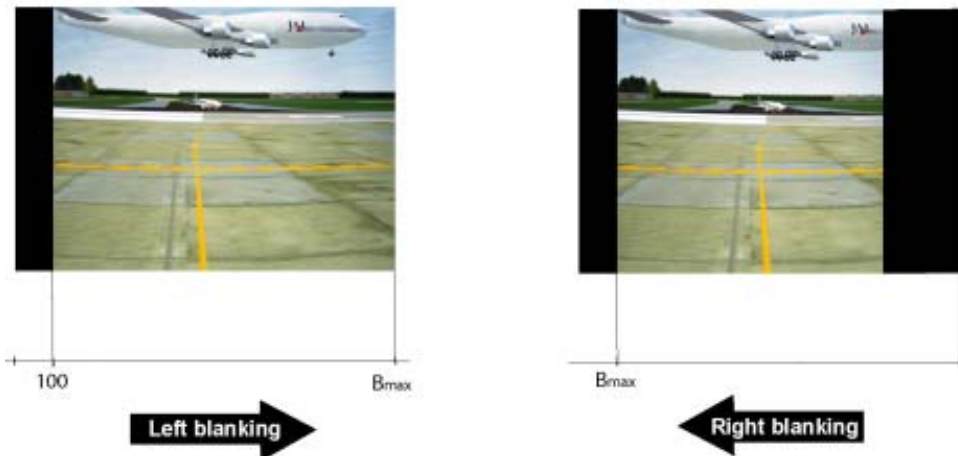

Image 6-117



Note that here the blanking is only done on the display i.e. the setting is not saved in the image file. in other words only one type of blanking (setting) can be done independently of the source.

How to blank the image ?

1. Press **MENU** to activate the Toolbar
2. Press → to select the *Display setup* item
3. Press ↓ to Pull down the menu
4. Use ↑ or ↓ to select *Blanking*
5. Press **ENTER**

A slider box is displayed (image 6-118)
6. Use ←or →, the numeric keys on the remote, or the keypad to change the blanking.

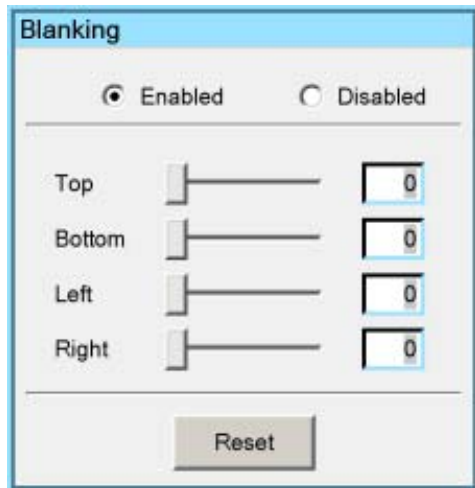

Image 6-118



Use the checkboxes to enable/disable the blanking
Use the Reset key to reset the blanking values.



The logo is also affected by the blanking

6.9.10 Soft Edge

Overview

- Introduction
- Soft Edge overlap zone (horizontal Soft Edge)
- Soft Edge border adjustment
- Black level of the images

6.9.10.1 Introduction

Why Soft Edge?

When working in a multichannel setup the projector and its Soft Edge possibilities allow an image blending that gives the appearance of a single view.

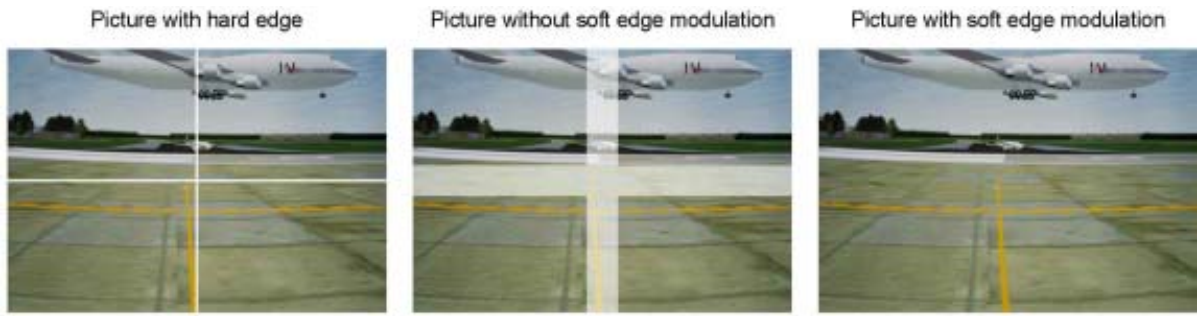

Image 6-119
Why Soft Edge?

What is the Basic Principal of Soft Edge?

The principle of edge blending is achieved by linear modulation of the light output in the overlap zone so that the light output in that zone equals the light output of the rest of the image.

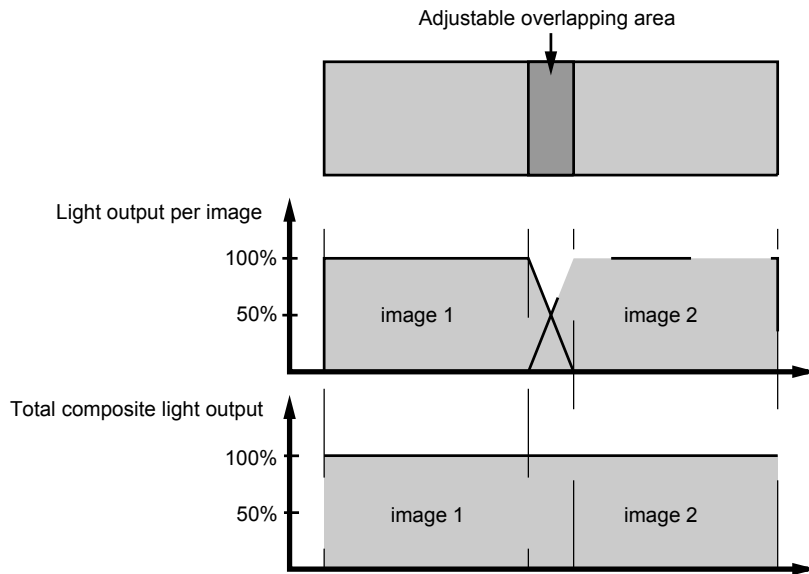

Image 6-120
Light modulation in Soft Edge

6.9.10.2 Soft Edge overlap zone (horizontal Soft Edge)

Definitions

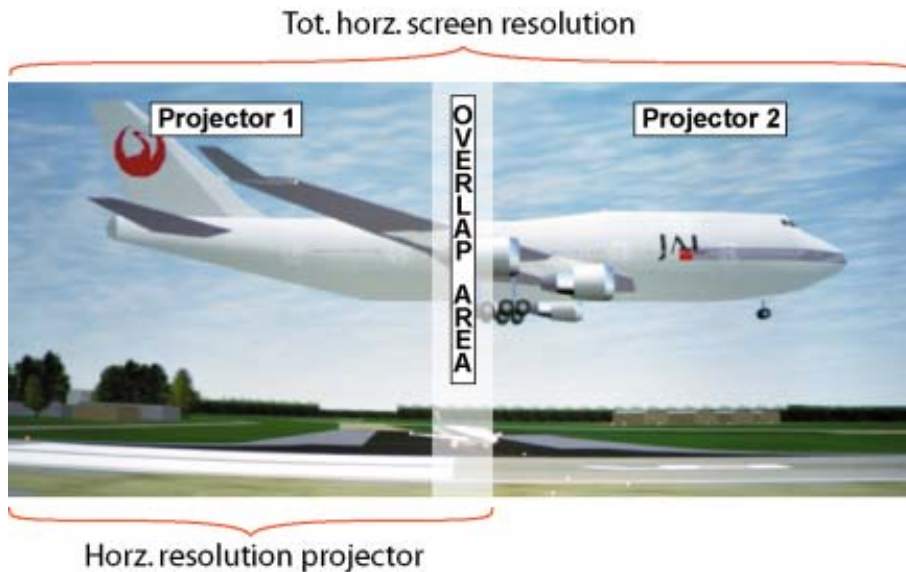

Image 6-121
Scenergix set up

Overlap : number of pixels that overlap

Horizontal resolution of 1 projector : 1400 for SXGA+ projectors.

Total horizontal screen resolution : [(horizontal resolution of 1 projector) x 2] minus overlap.

Horizontal Resolution source : number of active pixels of the source.

Adjustment of Active pixels (Pact) of the first projector

1. Go to File → Edit menu of first projector.
2. Enter value for horizontal active (= Pact) as follows :

$$\text{Pact} = [(\text{Horz. resolution of 1 projector}) / (\text{Total horz. screen resolution})] \times (\text{horz. resolution source})$$
3. Horizontal start (= Pstart) remains the same.

Adjustment of Active pixels (Pact) of second projector

1. Go to File → Edit menu of second projector.
2. Enter value for horizontal active (= Pact) as follows :

$$\text{Pact} = [(\text{Horz. resolution of 1 projector}) / (\text{Total horz. screen resolution})] \times (\text{horz. resolution source})$$
3. Horizontal start (= Pstart) = original start + [(Horz. resolution source) minus (newly calculated Pact)]

Example

Horizontal resolution source : 1600 pixels

horizontal resolution projector 1 & 2 : 1024 pixels

Overlap : 100 pixels

Total horizontal screen size in pixels : 1948 pixels

Pact projector 1 = $[(1024 / 1948)] \times 1600 = 841$ pixels

Pact projector 2 = $[(1024 / 1948)] \times 1600 = 841$ pixels

Pstart projector 2 = Pstart projector 1 + (1600 – 841)

6.9.10.3 Soft Edge border adjustment

What can be done with the Soft Edge border menu?

Within this menu the width of the blending zone is set up.

How to select a border?

1. Press **MENU** to activate the menu bar.

6. Advanced

2. Press → to select the *Display setup* item. (image 6-122)
3. Press ↓ to pull down the *Display setup* menu.
4. Use ↑ or ↓ to select *Soft Edge*.
5. Press → to select the *Soft Edge* item.
6. Use ↑ or ↓ to select *Border*.
7. Press **ENTER** to select.
A dialog box will be displayed. The actual Soft Edge border will be displayed.
8. Use ↑ or ↓ to select the desired adjustment.

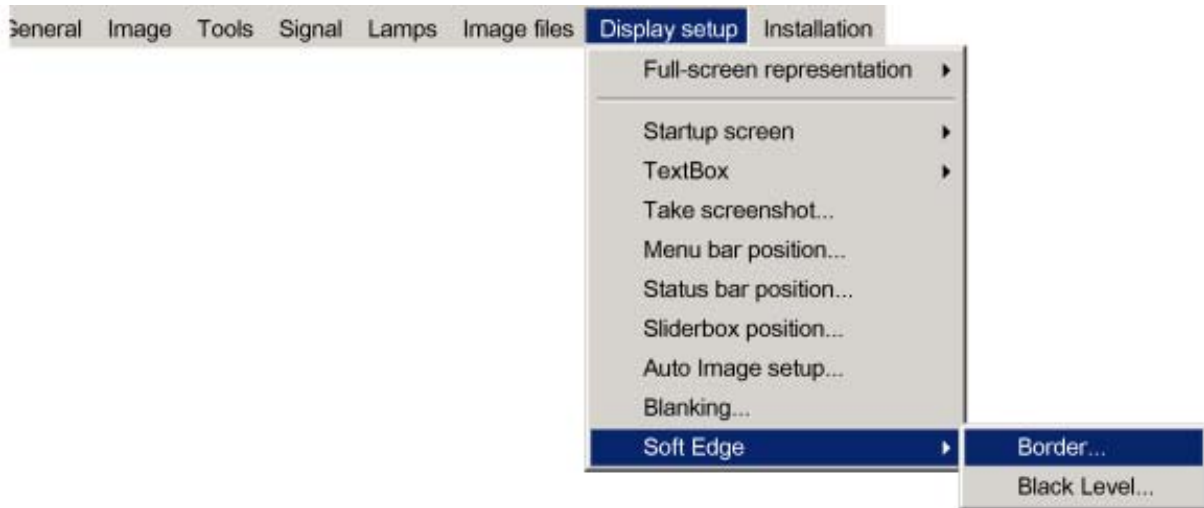

Image 6-122

Adjusting with the arrow keys.

1. When on an adjustment, use the → or ← key to move the border line to the desired position.
The border line will move in the desired direction and the light output in the overlap area will be adapted to. (image 6-123)
Set first the width of the first projector and repeat for the second one. (image 6-124, image 6-125)

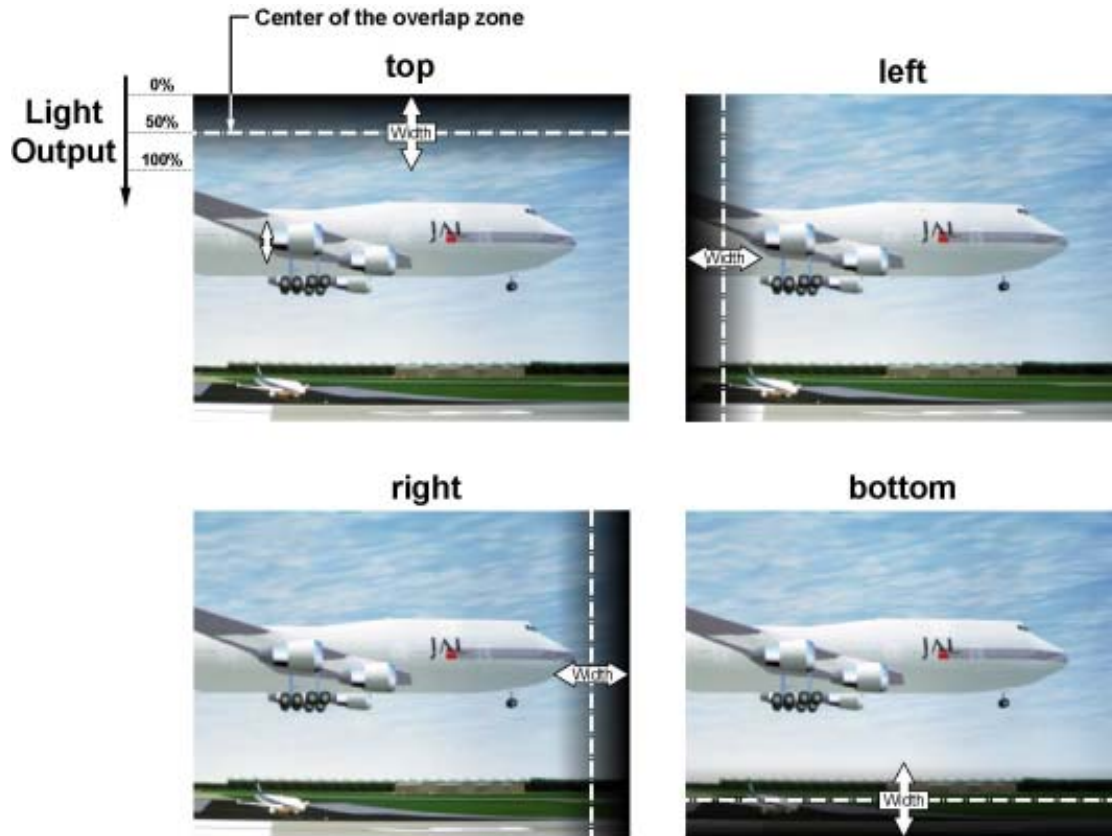

Image 6-123
Width selections

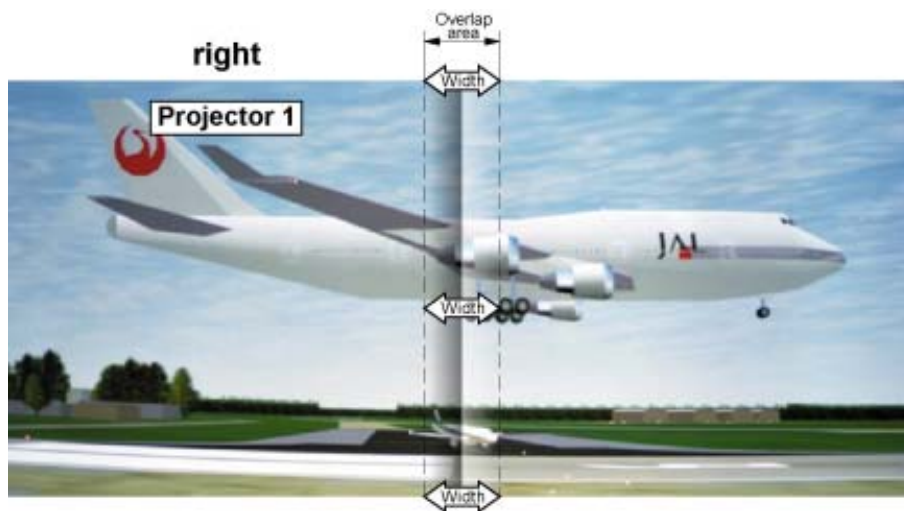

Image 6-124
Width set up for projector 1

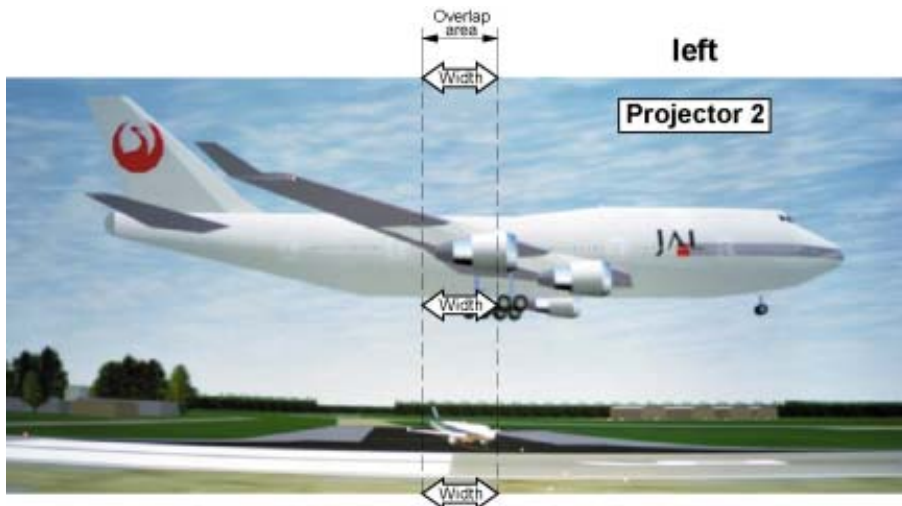

Image 6-125
Width set up for projector 2

Adjusting by entering the exact values.

1. When on an adjustable item, the input box background will be colored. Press **ENTER**.
The value will change to a 3 digit value and the first digit is selected.
2. Enter a value with the digit keys on the remote control.
The cursor jumps automatically to the next digit.
3. Press **ENTER** to activate the new value.



Use reset to return to the default settings.

6.9.10.4 Black level of the images

Why

For dark images, the overlap zone will be brighter than the rest of the images. Therefore we can rise the black level of the remaining image (excluding the overlap zone)

How to adjust

1. Press **MENU** to activate the menu bar.
2. Press → to select the *Display setup* item. (image 6-126)
3. Press ↓ to pull down the *Display setup* menu.
4. Use ↑ or ↓ to select *Soft Edge*.
5. Press → to select the *Soft Edge* item.
6. Use ↑ or ↓ to select *Black level*.
7. Press **ENTER** to select.

A dialog box will be displayed on a black level background.

Adjust the black level of area A until the black level of area A, B and C or equal (area C should be adjusted on the second projector). (image 6-127)

Use the up or down arrow key to select the adjustment (All, Red, Green or Blue)

Use the left or right arrow key to select the adjustment direction and speed.

Press **ENTER** to increment or decrement the value.

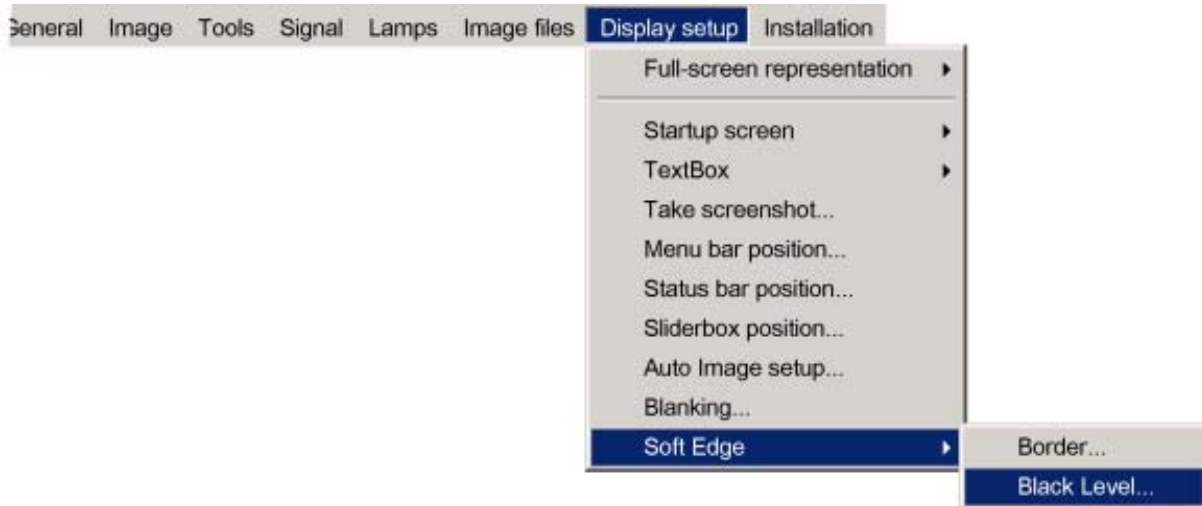
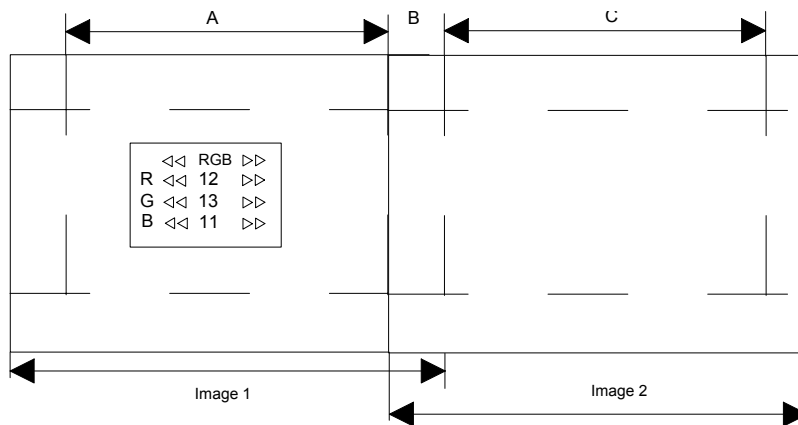

Image 6-126

Image 6-127
Black level adjustment

6.10 Installation

Overview

- Lens adjustments
- Security
- Change password

6.10.1 Lens adjustments

What can be done ?

Motorized lenses can be adjusted in the installation menu or via the dedicated keys on the remote.

The following parameters can be adjusted:

- Zoom
- Focus
- Shift (also for non motorized lenses)

How to Zoom/focus or shift ?

1. Press **MENU** to activate the Toolbar
2. Press → to select the *Installation*
3. Press ↓ to Pull down the *Installation* menu
4. Use ↑ or ↓ to select *Lens adjustment* (image 6-128)

5. Press **ENTER**

A textbox appears on the screen, follow the instructions. (image 6-129, image 6-130)

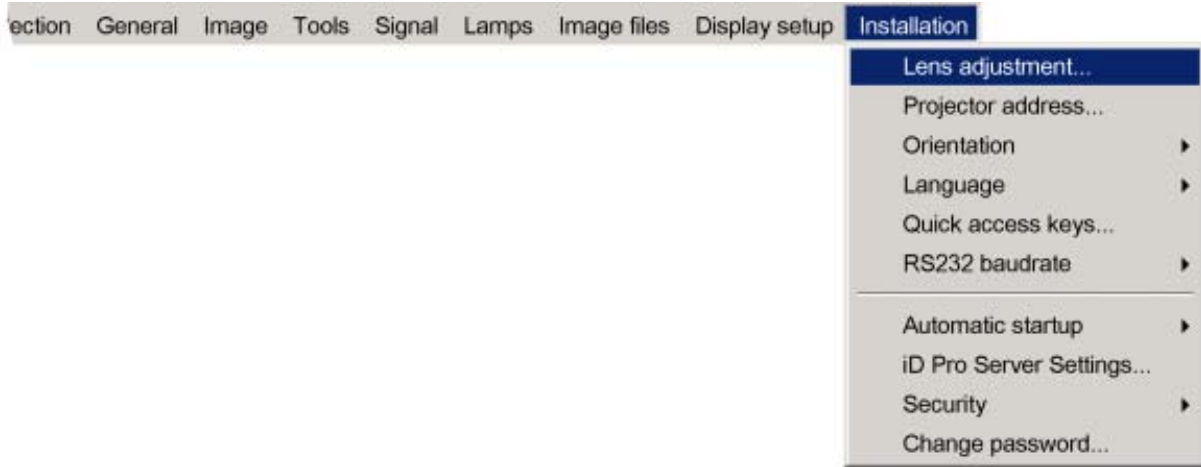

Image 6-128

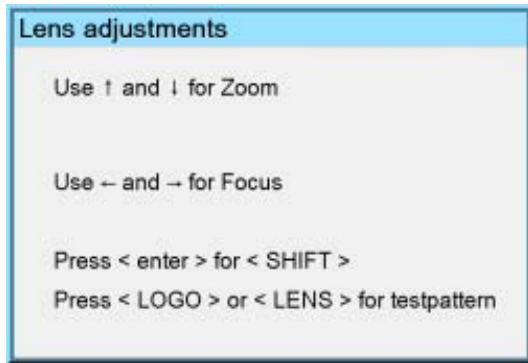

Image 6-129

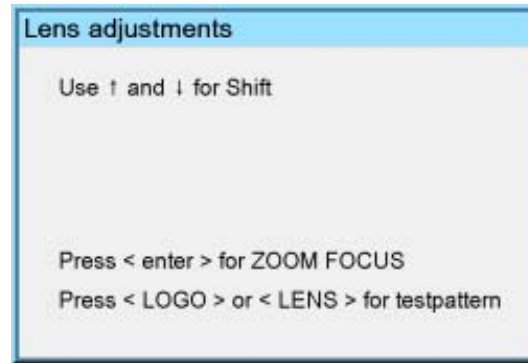

Image 6-130

6.10.2 Security

What can be done ?

A security function is implemented in the projector and allows a protection against theft.

A PIN code allows the user to lock the projector in case of wrong code entry.

The PIN code must be entered at each start up (Power ON), entering three times a wrong number triggers a wait cycle of 15 minutes, the second 3 wrong codes a wait cycle of 30 minutes, 1 hour, ...

The security mode can be enabled or disabled.

How to activate the security mode ?

1. Press **MENU** to activate the Tool bar
2. Press → to select the *installation* item
3. Press ↓ to Pull down the menu
4. Use ↑ or ↓ to select *Security* (image 6-131)
5. Press → to open the menu
6. Use ↑ or ↓ to select *ON*
7. Press **ENTER**

A dialog box is displayed (image 6-132)

8. Use the arrow keys to select YES and press **ENTER** to confirm

A dialog box is displayed

Enter your name, company name,... (this information is displayed in the identification menu) (image 6-133)

9. Press ACCEPT

A dialog box is displayed.

Enter the PIN code, and confirm it. (image 6-134)

An informative text box is then displayed. Press **ENTER** or **BACK** to escape. (image 6-135)

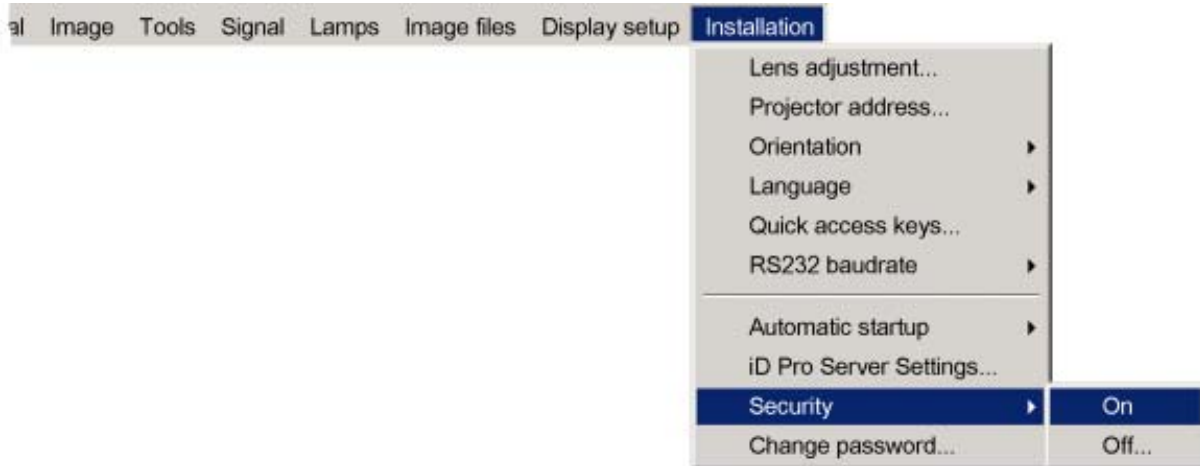

Image 6-131

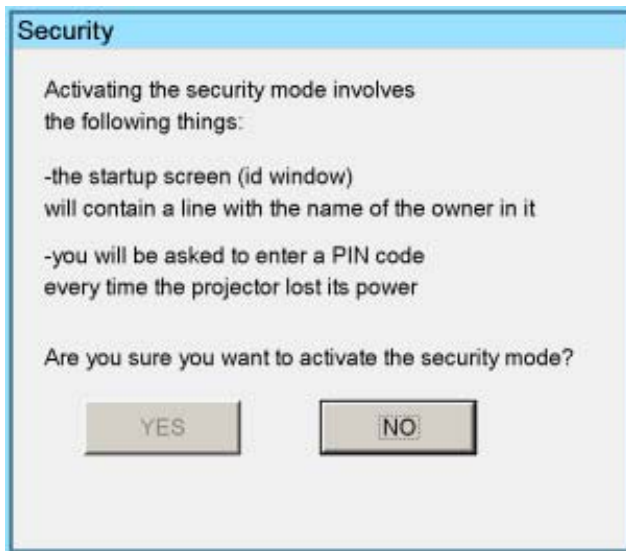

Image 6-132



Image 6-133



Image 6-134

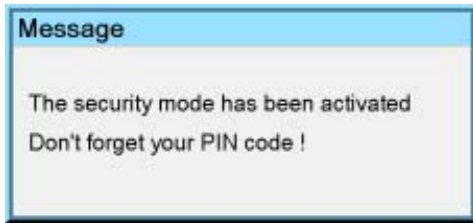

Image 6-135

How to disable the security mode ?

1. Press **MENU** to activate the Tool bar
2. Press → to select the *installation* item
3. Press ↓ to Pull down the menu
4. Use ↑ or ↓ to select *Security*
5. Press → to open the menu
6. Use ↑ or ↓ to select *OFF*
7. Press **ENTER**
A dialog box is displayed
8. Enter your PIN code
The security mode is now disabled

6.10.3 Change password

How to change the password ?

1. Press **MENU** to activate the Tool bar
2. Press → to select the *Installation* item
3. Press ↓ to Pull down the *Installation* menu
4. Use ↑ or ↓ to select *Change password* (image 6-136)
5. Press **ENTER**
A dialog box is displayed.
(image 6-137)
6. Use ← or →, the numeric keys on the remote, or the keypad to enter and confirm the new password.
Each character is displayed as an asterisk.

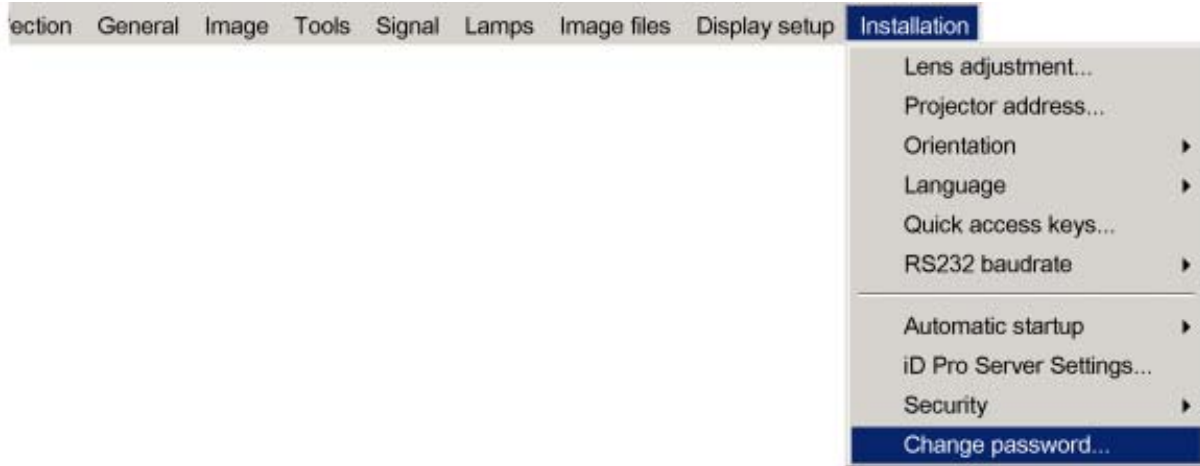

Image 6-136



Image 6-137



The new password is accepted if the new password and the confirmed password coincide.



If the password is forgotten contact a Barco authorized technician.

7. IQ NETWORK

**LAN**Local Area Network

**WAN**Wide Area Network

Overview

- Network architecture
- Network functionality
- iQ Pro Server specifications
- Getting started
- Control
- Management & diagnostics
- Configuration
- DropZone
- The Web client

7.1 Network architecture

**SBC**Single Board Computer,

**GUI**Graphic User Interface

Topology

The network centric projector (iCon and iQPro) uses an integrated PC (SBC) and can be connected to a LAN.

The projector performs the role of Server while each PC is declared as a Client within the system.

Each client PC has to be configured (projector IP address, ...), see "Configuring the client software"

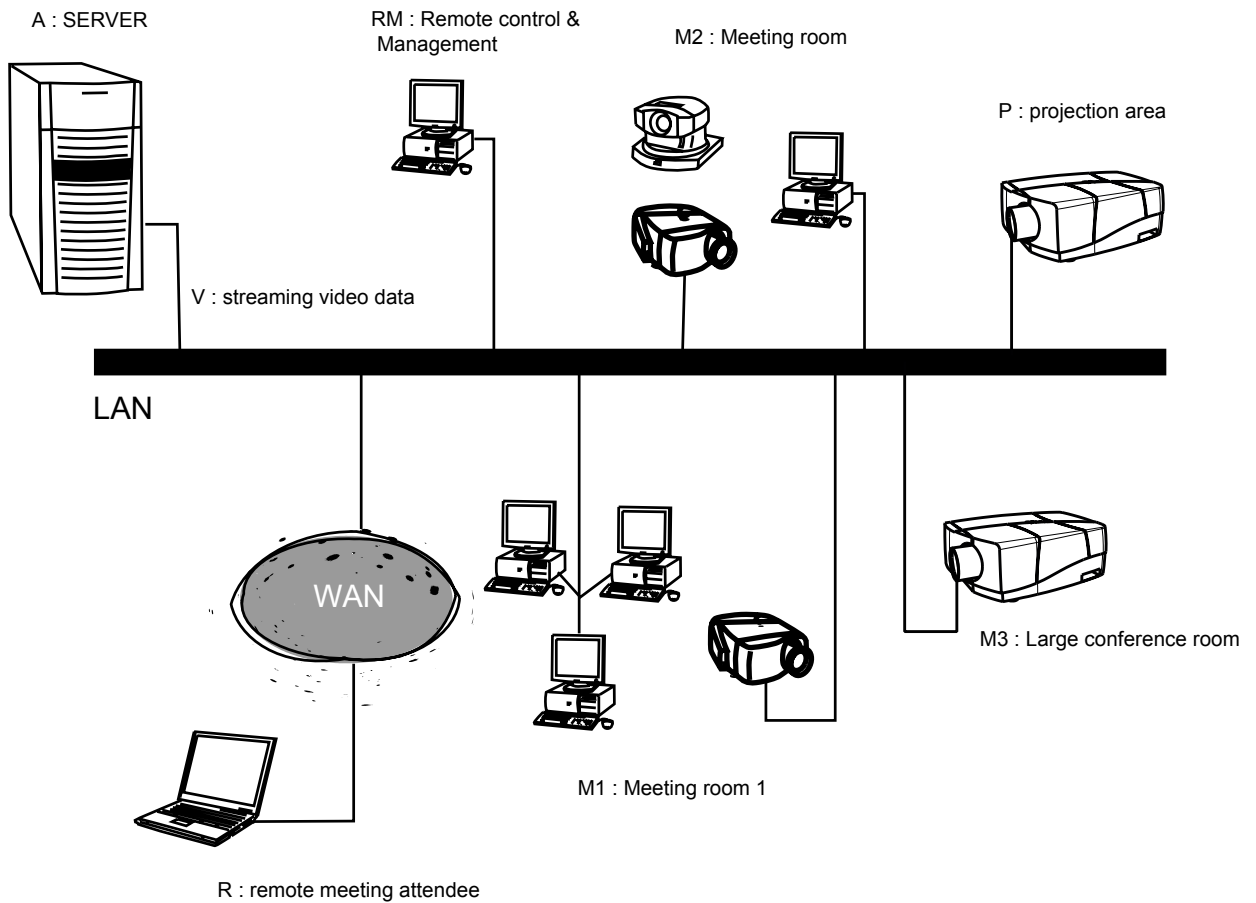

Image 7-1
Typical IQ Pro network architecture

- A server
- RM Remote Control and Management
- M1 Meeting room 1
- M2 Meeting room 2
- M3 Large screen conference room
- P Projection area
- R Remote meeting attendee
- V Streaming Video data



Wireless LAN (point-to-point) is also possible (using the PCMCIA connection on the projector) and complements the functionality of direct cabling.

7.2 Network functionality

What can be done ?

The network functionality allows the projector to perform several network functions thanks to network features which are required in most corporate environments:

- **Control & Management** : wireless/wired (remote) control and monitoring of the projector(s) thanks to a user-friendly GUI (the Client software).
- **Diagnostics** : diagnostics through a user-friendly GUI and automatic E-mail sending.
- Easy file (MS PowerPoint,...) manipulation and projection using the **DropZone** interface.
- **Remote control** of the projector by allowing the desktop to be shared over the network (the **DropZone** interface).
- **Streaming media** : The projector's onboard computer is streaming video data ready, i.e. allowing the decoding of video streaming data coming from a server via the LAN.



The network centric projector may be configured in the same way as a standard PC to support :

- **SNMP service** : provides diagnostics, basic control via SNMP messaging
- **Microsoft Exchange services**: for scheduling of projector tasks.
- **Web client** : offers an alternative to the Client software through a user-friendly internet based interface (includes almost the same features as the Client software)

See the Appendix “General guidelines on Network configuration” for general guidelines on how to enable these services.

7.3 iQ Pro Server specifications

Specifications of the iQ Pro Server platform

- 1.2 GHz Pentium III processor ⁴
- 256 MB RAM
- 40 GB Hard Disk storage
- Microsoft XP Operating System
- Barco Server Software for network communication between iQ Pro Server and clients

7.4 Getting started

Overview

- Connections
- Installing the software
- Start up of the BarcoReality SIM 5plus Server
- Configuring the client software
- Configuring the Server software



The installation of the iQ Pro in a Local Area Network must be done in the same way as the installation of a standard PC in that particular network meaning that the same rules and accepted practice should be respected.

The assistance of qualified IT personnel is advised.



CAUTION: Important !

A Virus protection program should be installed and kept up to date to prevent virus infections.



CAUTION: The maintenance of the Server must be done in the same way as a PC meaning that the same rules and accepted practice should be respected.

Backups should be taken on a regular basis.

In the same way virus updates should be done regularly.

Barco will not be held responsible for destroyed information in case of a hard disk breakdown or virus infection and has no obligation to pay for or reimburse for the cost of recovering data.

⁴ the pentium III socket is upgradeable

7.4.1 Connections

Front plate (Layer 3) layout

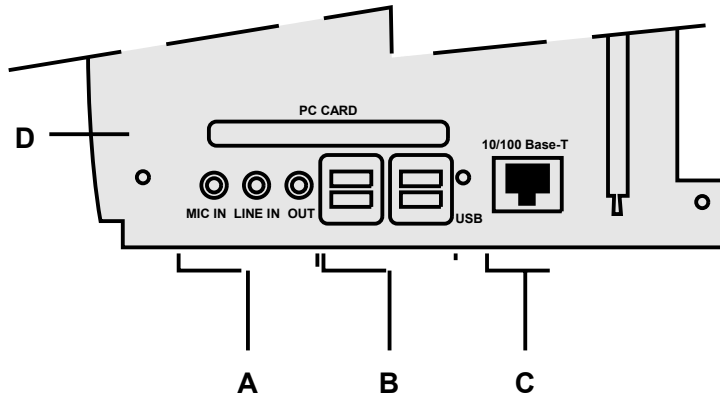

Image 7-2
iQ Pro front plate (network layer)

- A audio connections : mic input, line input, output
- B 4 x USB connection
- C RJ45 connector for network connection
- D PCMCIA slot

How to connect the Single Board Computer ?

1. Use the RJ45 connector to connect the SBC to the installed network
2. Use the USB ports to connect peripherals such as mouse, keyboard,... (image 7-3)
 - Note:** Keyboard access during pre-operating system boot (to access BIOS or F8 key to get operating system select menu) is only supported on the bottom USB input connector next to the Ethernet connector
3. Use the PCMCIA slot to connect a Wireless LAN card or other optional inputs like Bluetooth, Modem cards,...
The slot is protected from dust by a slot door, open the slot door to insert a card.
 - Note:** recommended card type:
 - The card should be a type II card.
 - The card should be Windows™ XP compatible
4. Use the Audio connectors to connect an audio source or microphone, the output allows to use an external audio peripheral such as an amplifier etc.

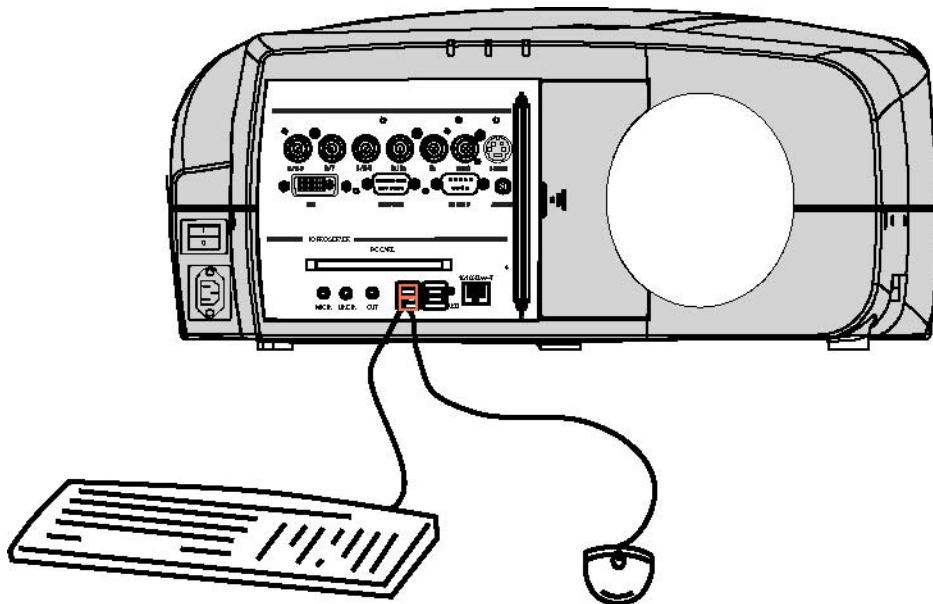

Image 7-3



Point to point configuration

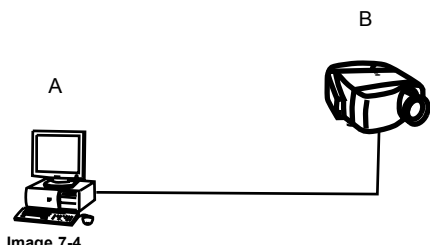

Image 7-4

In case of a temporary configuration (demo purposes) one can use the point to point configuration, the connection being done via RJ45 connections using a crossed UTP cable.

7.4.2 Installing the software



An Administrator password has been installed for security reasons (worm and virus protection):

Password : Barco (case sensitive !)

Necessary parts

- installation CD (delivered)
- PC

How to install the client software ?

1. Install the client software from the CD (Setup file)

How to install the server software ?

1. The server software is by default installed on the projector.
if necessary, reinstall it from the CD.



The CD containing the server software and the client tools are delivered with the projector. They can always be downloaded from the secured PartnerZone Web site : <https://secure.barco.com/presentation/>

7.4.3 Start up of the BarcoReality SIM 5plus Server

Starting up

There are 2 methods to start up the BarcoReality SIM 5plus Server

- Manual start up (via the *General* menu)
- Automatic startup at projector startup: this is done by defining the state of the BarcoReality SIM 5plus Server during a "Projector ON state" and a "Projector standby state".

Manual start up: How to start up/shut down/reset the BarcoReality SIM 5plus Server ?

1. Press **MENU** to activate the Toolbar
2. Press → to select *General*
3. Press ↓ to Pull down the General menu
4. Use ↑ or ↓ to select *iQ Pro Server*
5. Press → to open the menu
6. Use ↑ or ↓ to select *ON/OFF/Reset* (image 7-5)
7. Press **ENTER**

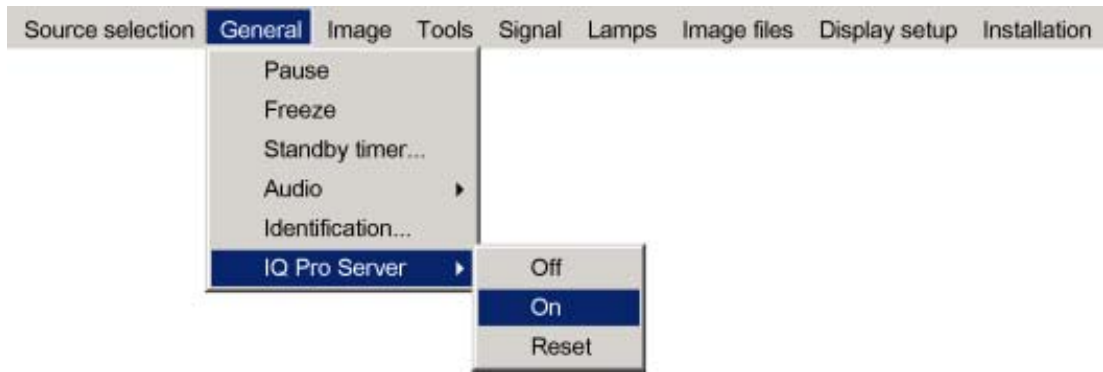

Image 7-5



When resetting the PC the menuitems in the BarcoReality SIM 5plus Server menu are greyed out during a short period.

Projector Standby state setting

This setting defines what should happen with the BarcoReality SIM 5plus Server when the projector is switched to standby. The BarcoReality SIM 5plus Server can stay in the ON state or it can be switched OFF

Projector On state setting

This setting defines what should happen with the BarcoReality SIM 5plus Server when the projector is switched on. The BarcoReality SIM 5plus Server can stay OFF (switching on can then happen manually in the general menu) or it can be switched on (at the same time as the projector)

Automatic start up: How to set the automatic startup ?

1. Press **MENU** to activate the Toolbar
2. Press → to select *Installation*
3. Press ↓ to Pull down the menu
4. Use ↑ or ↓ to select *BarcoReality SIM 5plus Server settings*
5. Press **ENTER**
6. A dialogbox is displayed (image 7-6)
7. Select *ON* for the “Projector On state” setting

The BarcoReality SIM 5plus Server will now be automatically switched on at the next startup of the projector

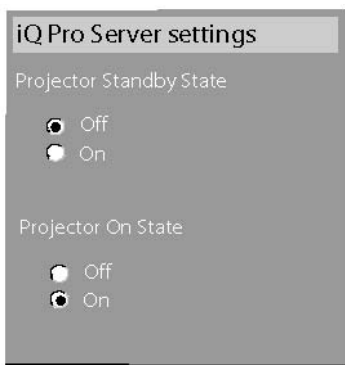

Image 7-6



The BarcoReality SIM 5plus Server will be switched on but not necessarily selected by default, go to Source selection in the menu to select the iQ PC.

7.4.4 Configuring the client software



The same universal client interface is used for different network centric projectors (iQ, iD, iCon). The layout of the interface (position of the controls,...) is adapted after detection of the projector type. Some screenshots may not fully coincide with the reality.

How to start up the client software ?

1. Start up the previously installed client program
 - The interface shows 3 tabs (upper tab control) : Control, Diagnosis and Configuration
 - The active sub interface is the control sub screen (image 7-7)
2. Click on the upper menubar to select the desired sub interface

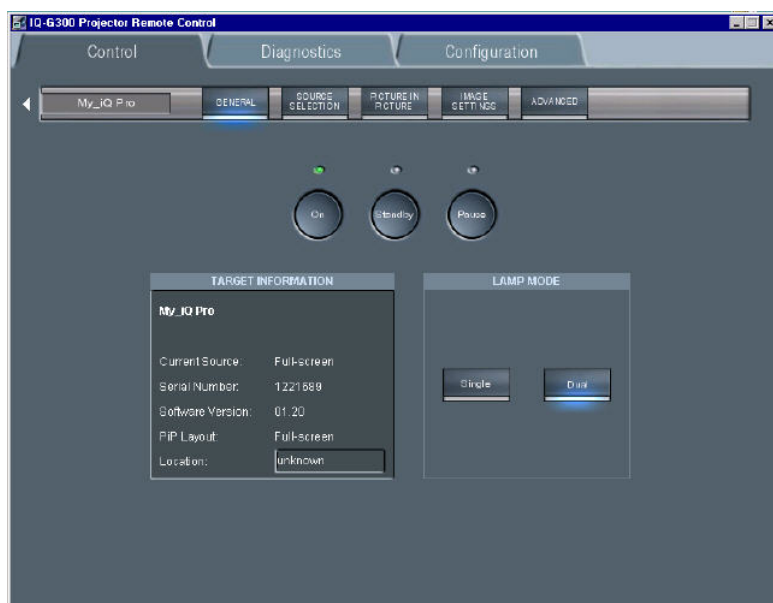

Image 7-7
Control interface



IP

Internet Protocol. The network layer of TCP/IP. Required for communication with the internet.

How to add a projector to the projector list

1. Click on the white arrow (image 7-8)
 - A menu is dropped down (image 7-9)
2. click on the + sign of the projector list
 - A dialog box is displayed (image 7-10)
3. Fill in the Name, the IP address (optional) and the Port number of TCP/IP connection

Note: default port number = 9999
4. Fill in the alias

Tip: "Alias" is a custom name whereas "Name" is the name by which the projector is identified on the (corporate) network
5. Click OK to confirm or Cancel
 - The projector is now added to the list of projectors



Image 7-8

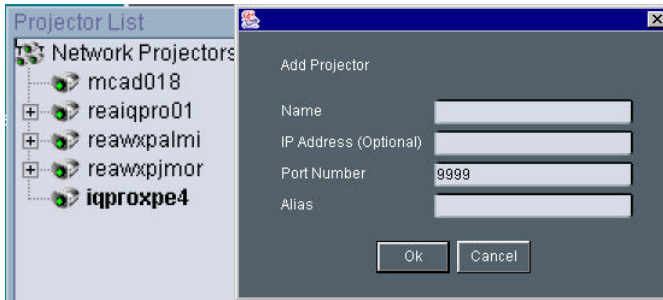

Image 7-10



Image 7-9
projector list: contains a projector and a projector group sub list



Depending on the installed network (use of DHCP server or not), the IP address may be needed to be entered or not.



For a point to point installation the projector's IP address must be entered manually.
Check the operating system on the for the IP address, or contact your IT administrator.

How to add a projector group to the projector group list ?

1. Click on the white arrow
A menu is displayed, image 7-9
2. Click on the + sign of the projector group list
A dialog box is displayed (image 7-11)
3. Fill in the group name
4. Click OK to confirm or Cancel
The group is now added to the list of groups



Image 7-11

How to add projectors to a group ?

1. Click on the projector to be added in the projector list
2. Drag the projector down to the projector group.

The projector is added to the group.



Adding a projector to a group can also be done by using the "Copy + Paste" method on the right mouse button menu.

How to connect to a projector or group of projectors ?

1. Double click on the projector or group of projectors

A green dot appears, indicating that the projector is present on the network and working properly (image 7-12)

The name of the projector or group is now displayed in the upper part of the screen and indicates that the communication has been set (image 7-13)



Image 7-12
connected and active projector

A connected and active projector



Image 7-13

A connected and active projector



When connected to a group of projectors, some controls may be disabled.

In general, controls will only be selected if this is the status of all projectors in the group.

Sliders will be set to a particular value only if this is the same on all projectors in the group, otherwise they will be positioned centrally with a dash in the value box. When the slider is moved the box will show the new value and this value will be sent to all projectors in the group.

Labels such as Current Source in the general page will only be shown if the string value is the same on all projectors, otherwise a dash will be shown

The Target information block

The target information block displays the main characteristics of the connected projector or group of projectors.

This gives also an indication whether the communication setting has been successful or not.



Image 7-14

7.4.5 Configuring the Server software

Internal network connection

The internal connection (firmware connection) between the projector controller and the single board computer uses fixed IP addresses.

The IP address of the SBC can be found in control panel

- SBC: IP address = 192.168.42.51, subnet mask = 255.255.255.248



Projector Controller's IP address = 192.168.42.50

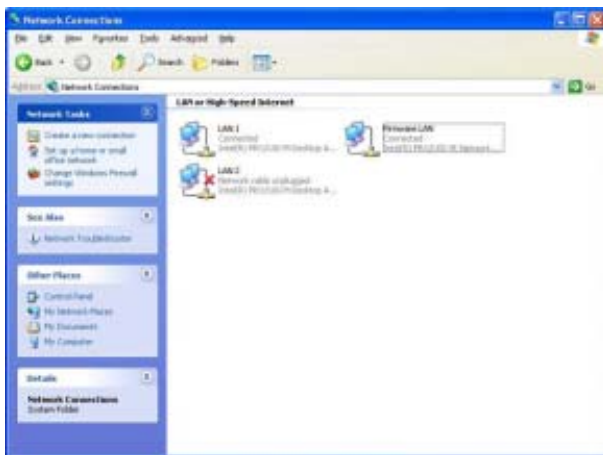

Image 7-15

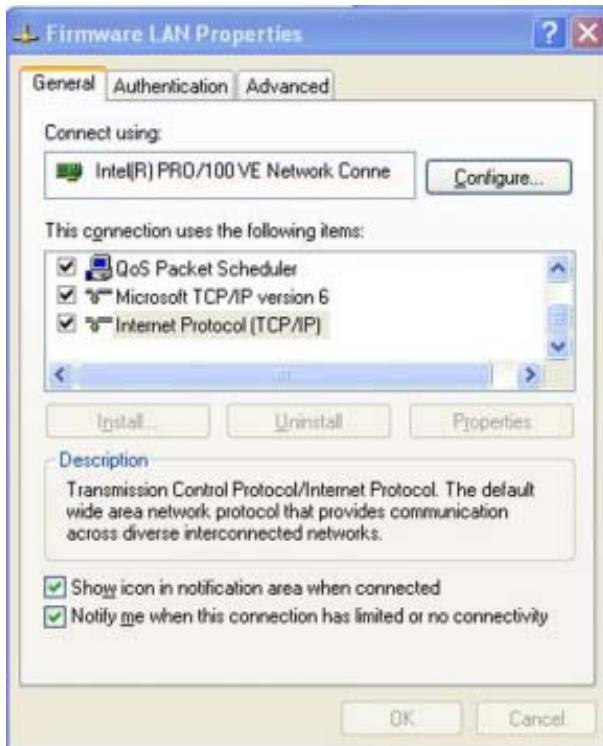

Image 7-16

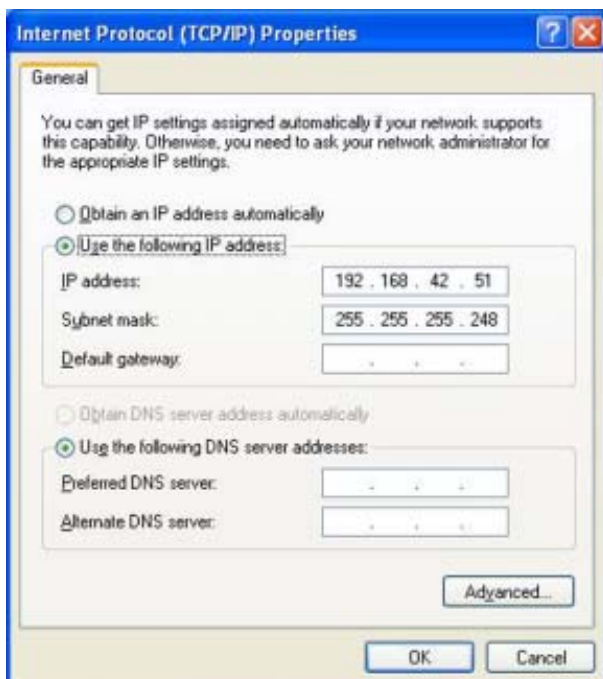

Image 7-17



CAUTION: Leave these IP addresses unchanged !

The server menu

The server menu can be opened by right clicking from the server tray icon

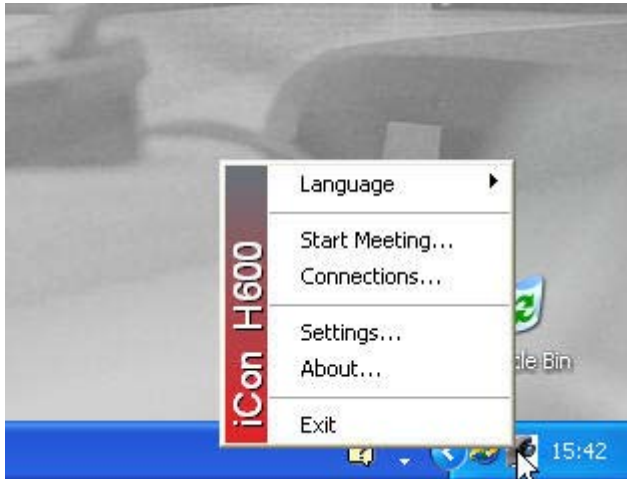

Image 7-18

Start Meetings control

The meeting control is started and positioned on the desktop, through out the meeting it will allow to :

- Accept requests interactively : a request for a desktop sharing from a client PC must be accepted on the iCon server, a dialog box is displayed on the iCon asking to accept or decline the desktop sharing request
- Deny all requests : all request are denied
- Accept all requests automatically : desktop sharing is always accepted at the iCon (server) without prompting for confirmation
- Notify end of meeting at : allows to set a reminder at expected end time of the meeting



Image 7-19

How to configure the Server settings ?

1. Go to the server icon in the lower task bar of the desktop and click the right mouse button.
A menu is displayed
2. Select *Settings*
A dialog box is displayed allowing to select different tabs
 - Networking
 - Dropzone, see Dropzone chapter
 - Exchange

Networking settings

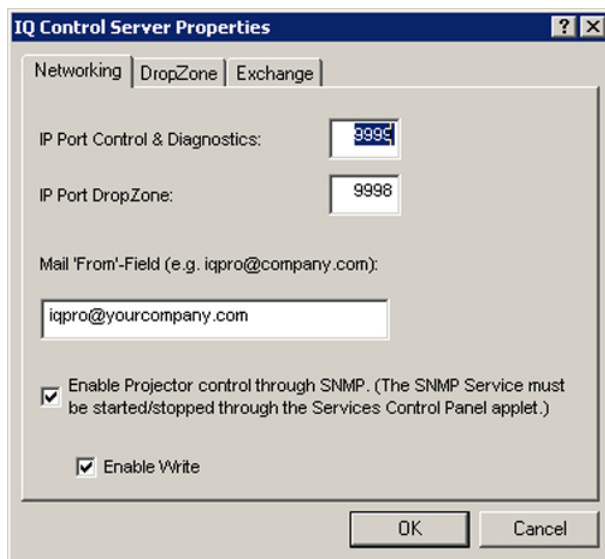

Image 7-20

- Port settings: it is advised to leave these settings in their default value.
- Mail to field : see mail configuration in the client software
- SNMP enable: allows to enable the SNMP control of the projector.
The *Enable write* option allows to enable the client to overwrite projector settings via SNMP.
Unchecking this option means that projector settings will only be read.

Exchange settings

This tab allows to fill in the exchange parameters to allow scheduling of projector tasks.

These parameters should be configured by your local IT administrator



Image 7-21

Miscellaneous settings

This tab allows following settings :

7. IQ Network

- Enable password protection : when using a password, one must enter it when starting up the client interface
- Automatically open sole document ... : when using a USB stick, the document is automatically opened (only when one document present).



When using a password, the control via the previous V1.1 client version will not be possible therefore disable password protection. Note that using a previous client version in combination with V1.2 server is indicated with following text box :



Image 7-22
client-server soft incompatibility



Image 7-23



To check the server version open the about menu from the tray



Image 7-24

7.5 Control

Overview

- Description
- How to use the control manager?
- General
- The source selection screen
- The PiP screen
- Image settings
- Advanced control

7.5.1 Description

What can be done ?

The projector allows a software client (client PC) to communicate locally with the server and hereby control the projector's settings, in this case one has a **point to point** communication, image 7-25. The client PC or laptop communicating with the projector may be locally installed or may be remote, communication may then happen over a LAN, image 7-26

The projector performs the role of Server while the PC acts as a Client within the system.

The control and management client software includes the possibility to create groups of projectors and that way control a whole fleet of projectors.

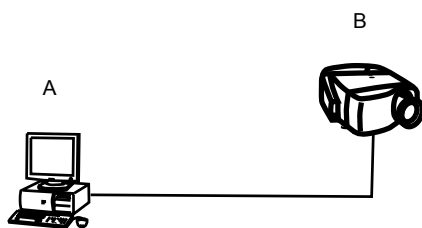

Image 7-25
point to point IQ Pro network communication

A facility manager's desk
B projector area

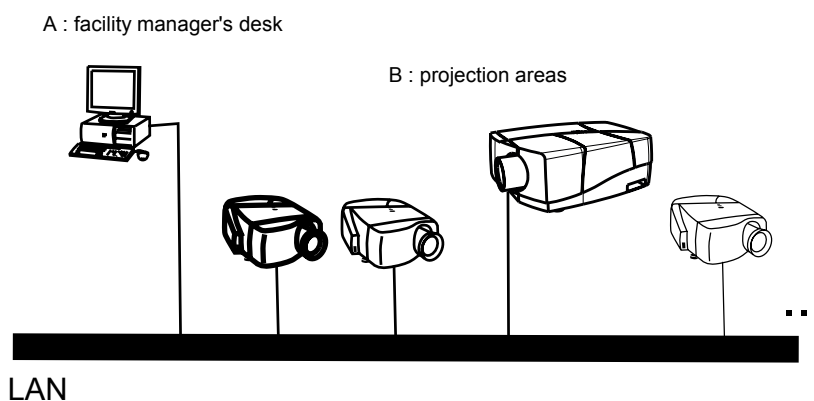

Image 7-26
control & management of network centric projector(s)

A facility manager's desk
B projector area

What can be controlled ?

Almost every menu item can be controlled through the control manager

- standby on/off
- lamp mode
- source selection
- switching effects
- background setting
- all PiP settings (layout, window)
- Image settings
- lens adjustments

The control manager

The control interface in the client software is divided into 5 subscreens, image 7-27:

- General
- source selection
- PiP
- image settings
- advanced

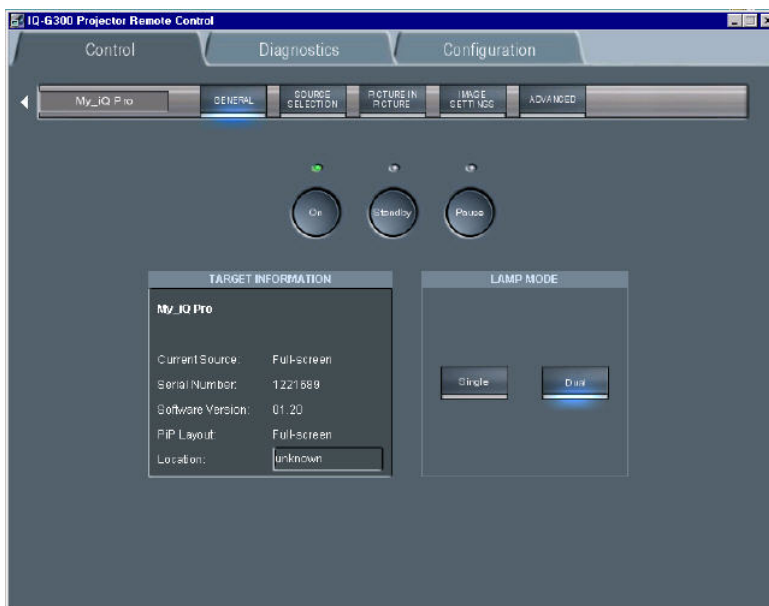

Image 7-27
The control interface: the general sub screen is active (see tool bar)

7.5.2 How to use the control manager?

How to use the control manager?

1. Choose the sub screen by clicking on the desired item on the tool bar in the upper part of the control interface
The active sub screen is indicated with a blue spot

7.5.3 General

What can be done ?

Basic controlling, monitoring and general parameter setting of the projector can be done in this screen, image 7-27.

- 3 buttons *ON*, *STANDBY* and *PAUSE*
- The *target information* part gives the main characteristics of the projector
- 2 buttons allow to switch between dual and the single lamp mode

How to change the general settings?

1. Click on the lamp mode button to select the desired mode
A blue spot indicates the active mode
2. Click on one of the three buttons to start up, pause or put in standby the projector
A green led indicates the status of the projector.

7.5.4 The source selection screen

What can be done ?

- A source selection dialog box allows to visualize all the sources or only the detected sources.
- 3 buttons to activate, freeze, pause and logo
- selection of 12 different switching effects
- selection of 3 different backgrounds: logo, Blue, Black

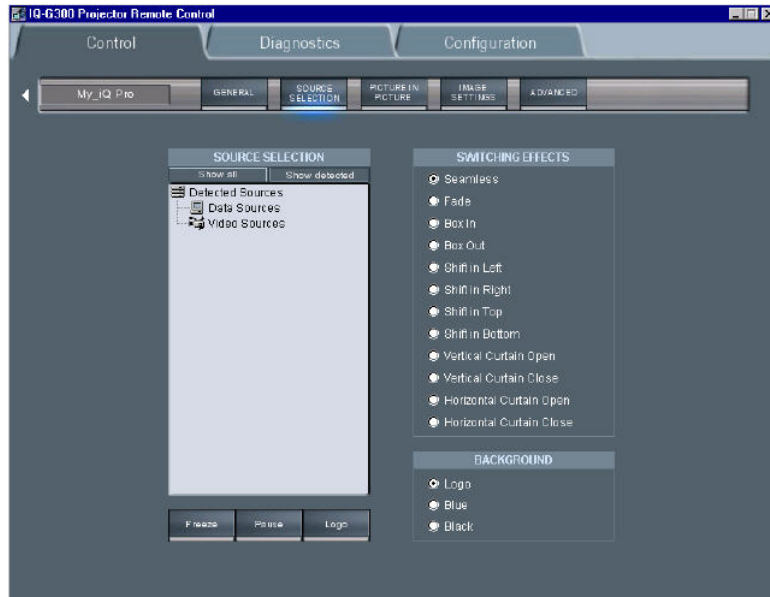

Image 7-28
The source selection screen

How to select a source ?

1. Click on *show all* or *show detected*

Depending on the option (show all/detected) selected, a list is displayed.

In case *show all* is selected, a list of all possible sources is displayed, signal presence is indicated with an orange dot.

When *show detected* is selected, all the detected sources are displayed with an orange dot.

2. Double click on the desired source

The selected source is now projected



In group mode there are only grey or green nodes, no orange (detected).

On start up, a green node will be shown when all projectors are playing the same source type.

Grey will be shown when some of the projectors are not showing the same source type.

If we double click on a grey node, it should go green as long as at least one of the projectors in the group can show the source.

7.5.5 The PiP screen



Following screenshots are taken for an iQPro projector. The layouts may be slightly different for an iCon (layout automatically adapted after projector type detection by the client).

What can be done ?

The PiP tool allows to manage the PiP of the projector in a more user friendly way:

- a check box list allows to choose between 10 PiP layout (5 preset layouts and 5 personal layouts)
- several buttons allow operations on windows (add, remove) as well as on the PiP layouts (save, ...)
- a graphical screen allows easy altering of the PiP layout : re sizing, positioning of the different windows.

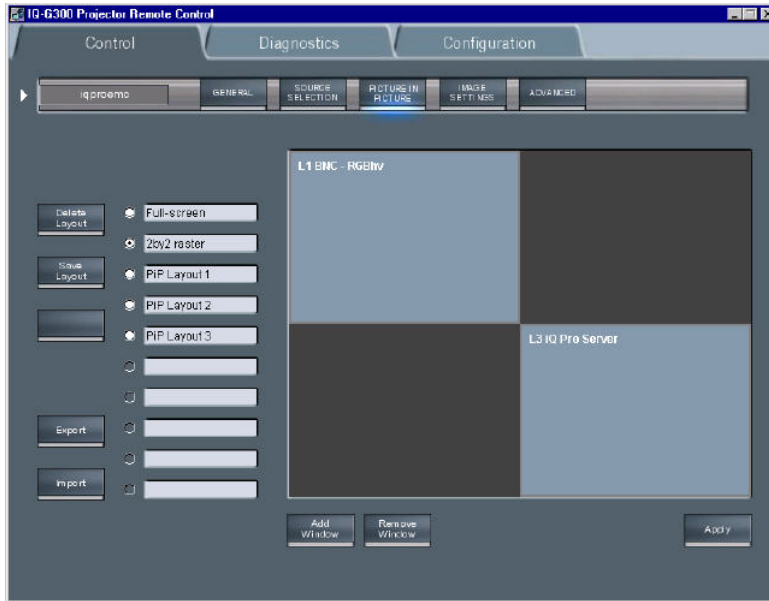

Image 7-29
PiP screen

How to perform operations on a PiP layout

As an example, let us choose a personal (non preset) layout, add a window, reposition the windows, and save the layout under a different name.

1. Click on one of the check boxes to choose a layout
 - Choose a personal layout (image 7-30)
 - The PiP screen (as well as the projected layout) is updated (image 7-31)
 - This layout contains one window being an RGBHV Data source
2. Click on the *Add window* button
 - Note:** if the layout already contains 4 window, it will be impossible to add a new one. In that case a window is displayed, image 7-32
 - A dialog box is displayed showing the possible sources to be added. (image 7-33)
3. Select the source to be linked to the new window.
 - The window is added to the layout. (image 7-34)
4. When entering the PiP screen the cursor is replaced by a hand, Click on the window to be repositioned.
 - The window is surrounded by a white frame.
5. Drag the window to the desired position.
6. Place the cursor on one of the corners of the window to be re sized.
 - A double arrow is displayed.
7. Drag to re size.
 - Note:** the window is re sized by keeping the same aspect ratio.

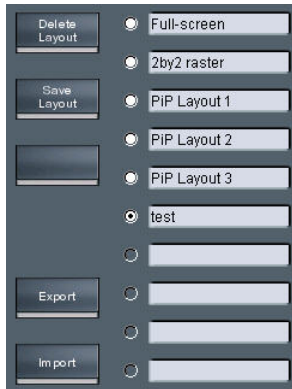

Image 7-30

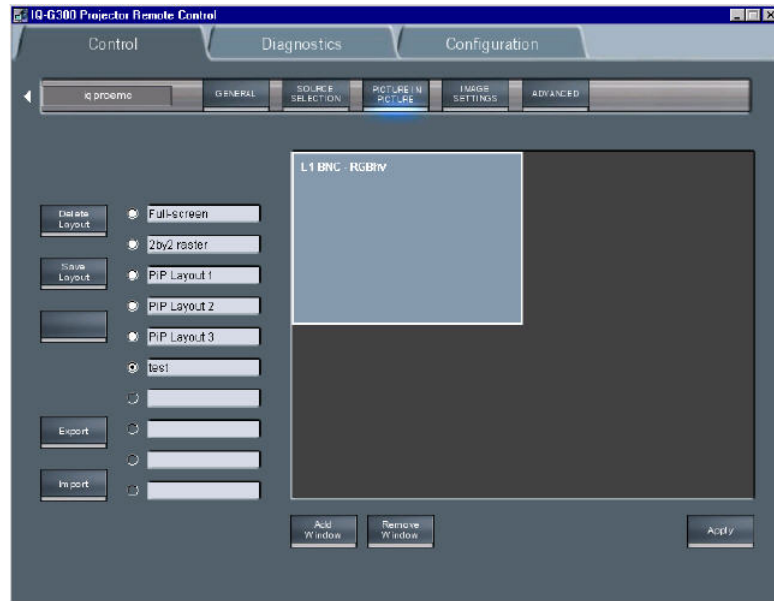

Image 7-31



Image 7-32

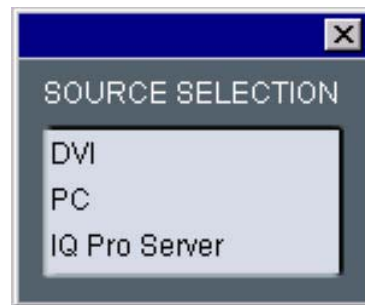

Image 7-33
Add window dialog box

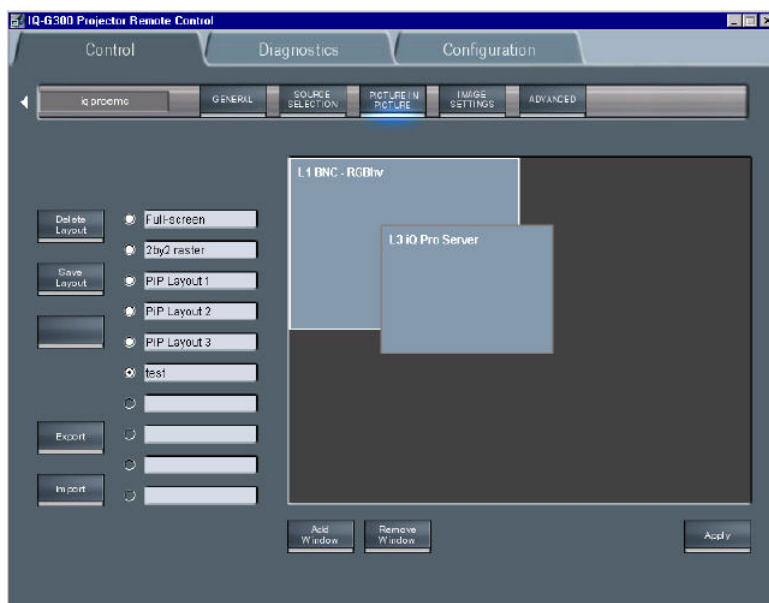

Image 7-34

Importing/exporting a layout

Every PiP layout can be exported and saved as backup on the network or on the hard disk of the Client PC.

It can then be imported at any time.

How to import/export a layout ?

1. Click on the *Export* button.
A dialog box is displayed. (image 7-35)
2. Browse to the desired location and fill in the filename.

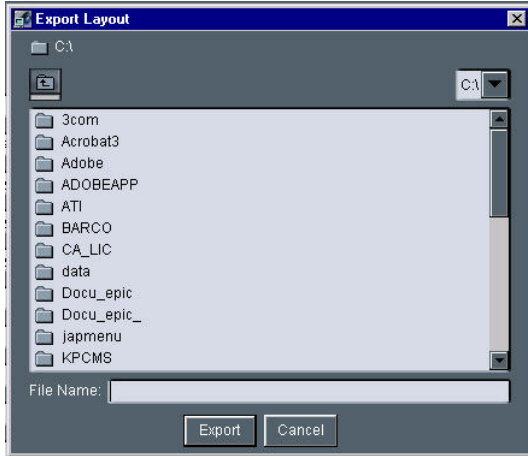

Image 7-35

How to import a layout ?

1. Click on the import button.
A dialog box is displayed. (image 7-36)
2. Select the layout to be imported.

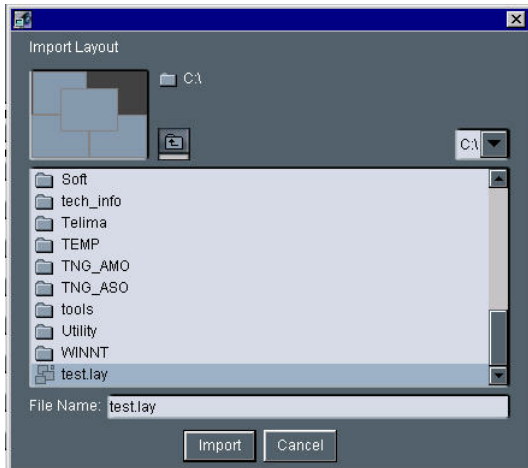

Image 7-36



For more information on Picture in Picture see the PiP chapter.

7.5.6 Image settings

What can be done ?

- General settings
- Color temperature
- Geometry

General image settings

1. Click on *Image settings* menu in the tool bar to drop down the submenu (image 7-37)
2. Click on *General*

- Slide the cursors to set the corresponding value (image 7-38)



Image 7-37

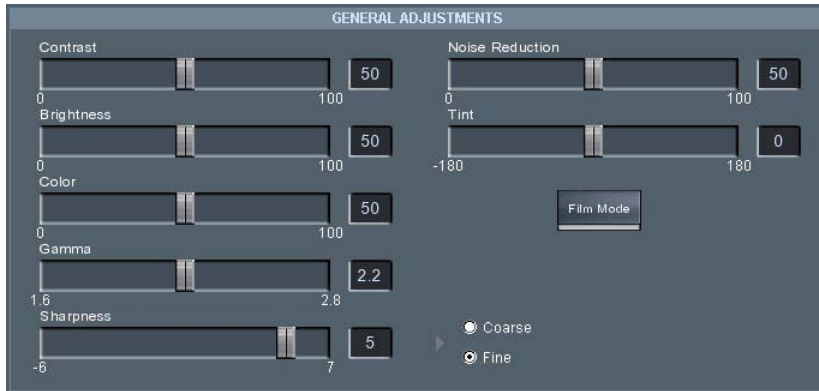

Image 7-38



Use the checkbox to define a coarse or a fine setting.



Click on the *Filmmode* button to enable or disable the filmmode.

Color temperature preset settings

- Click on *Image settings* menu in the tool bar to drop down the submenu.
- Click on *color temp*, image 7-37
- Click on the desired preset color temperature. (image 7-39)

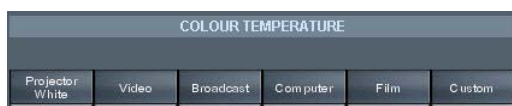

Image 7-39

Custom color temperature setting

- Click on the *Custom* button.
A dialog box is displayed. (image 7-40)
- Use the sliders to set the red and the blue color temperature.

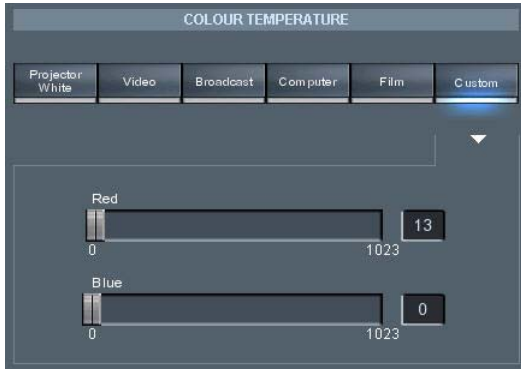

Image 7-40

Geometry settings

1. Click on *Image settings* menu in the tool bar to drop down the submenu. (image 7-41)
2. Click on *Geometry*.
a dialog box is displayed. (image 7-42)
3. Use the buttons to zoom or pan.
Tip: Use the buttons to choose small, medium or large adjustment steps.
Each click changes the setting.
4. Click on the desired aspect ratio and resolution handling mode.



Image 7-41



Image 7-42

7.5.7 Advanced control

Overview

- Lens adjustments
- Options

7.5.7.1 Lens adjustments

How to adjust the lens ?

1. Click on the *Advanced* menu in the tool bar to drop down the submenu
2. Click on *lens adjustments* (image 7-43)
3. Use the buttons to shift/zoom/focus the lens (image 7-44)
Tip: Use the buttons to choose small, medium or large adjustment steps.

Each click changes the setting.

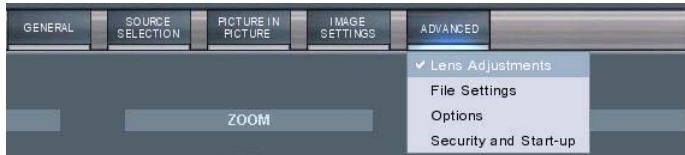

Image 7-43
the Advanced control submenu

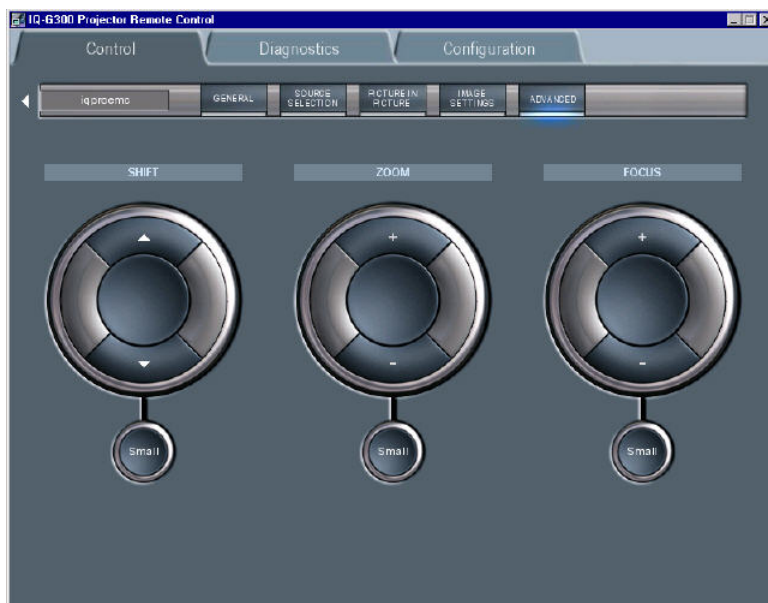

Image 7-44

7.5.7.2 Options

How to start up the options menu ?

1. Click on the *Advanced* menu in the tool bar to drop down the submenu.
2. Click on *Options* .
See image 7-45.

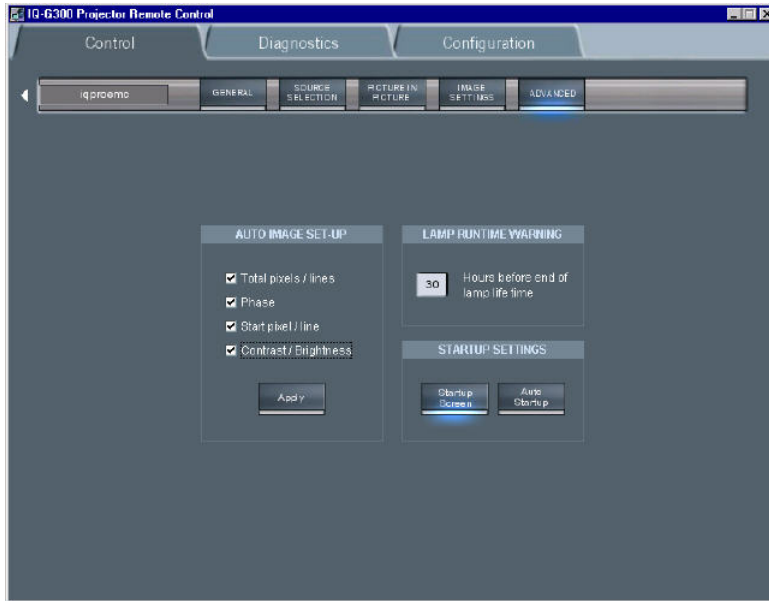

Image 7-45
The advanced Options screen

How to set up and perform AutoImage ?

1. Check the boxes corresponding to the desired setting of AutoImage. (image 7-46)
2. Click on Apply to perform AutoImage.

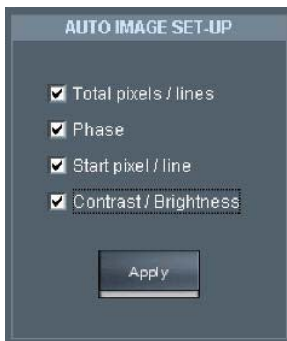

Image 7-46

Lamp runtime warnings startup settings

1. Fill in the lamp runtime warning time. (image 7-47)
2. Click on startup screen to enable the startup screen.
3. Click on Auto Startup to enable automatic startup.



Image 7-47



A blue spot indicates that the function is enabled.

7.6 Management & diagnostics

7.6.1 Description

What can be done ?

Diagnosis of a projector or a group of projectors is possible through on line monitoring. Mail services are also available and allow the client to be periodically informed about status errors and warnings concerning the different components of the projector.

What can be diagnosed/checked ?

- projector's general parameters as type, serial number, embedded SW version,...
- advanced diagnostics of the projector on board/component level: fpga, decoder,...
- user defined critical components (by E-mail feedback, see **E-mail configuration**)

7.6.2 Diagnostics manager

How to start up ?

1. Click on *diagnostics* in the main tool bar

How to check the general diagnostics ?

1. Click on *general* to view the general diagnostics

See image 7-48.



Image 7-48
general diagnostics screen

How to check the advanced diagnostics ?

1. Click on advanced to view the advanced diagnostics

See image 7-49.



Image 7-49
advanced diagnostics screen: green = OK ; red = error

7.7 Configuration

7.7.1 E-mail messaging

What can be done ?

E-mail messaging allows the projector to generate automatically E-mail and send them to three configurable recipients.

The mail can be sent on a regular basis i.e. daily, weekly or monthly or can be triggered by warnings.

Basically two different configurations must be done:

- content
- timing

Content configuration

The content configuration allows to define the content of the E-mail

- general content
- advanced content

Timing configuration

E-mail sending can be set to be time dependent or status dependent

- daily : E-mail is sent every day, the time can be set
- weekly: the day can be set with a calendar
- on warning : a E-mail is sent whenever a warning is generated by the projector

7.7.2 E-mail configuration

How to configure the E-mail ?

1. Click on *Configuration* in the toolbar
2. Click on *Mail Config* to open the mail configuration screen
See image 7-50.
3. set the content by clicking the desired content (image 7-51)
4. set the timing by clicking the desired time interval

Note: if the timing is chosen to be monthly, a calendar is displayed, click the days on which the E-mail should be sent

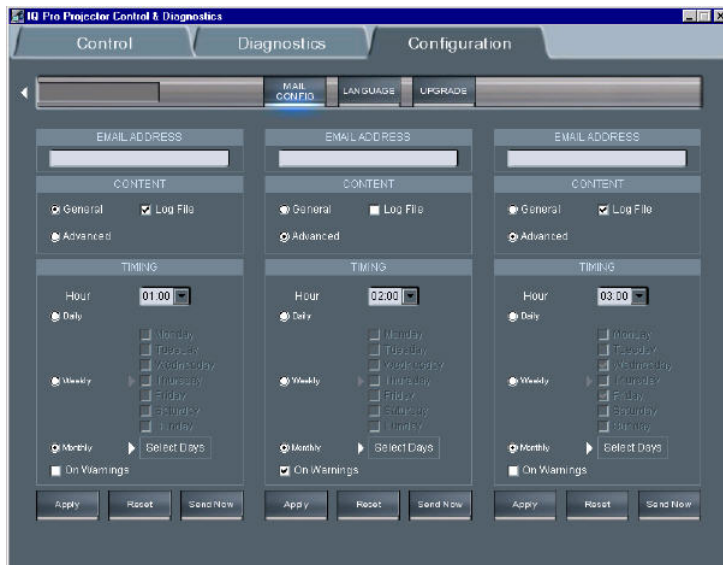

Image 7-50
mail configuration screen

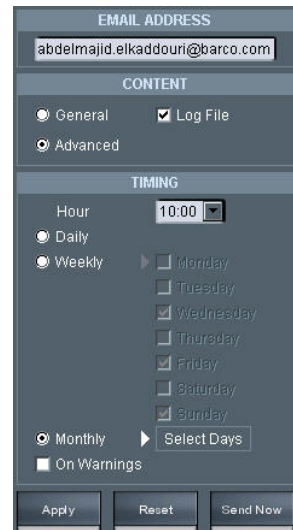

Image 7-51

Mail “from” configuration

The “from” field of the received mails i.e. the name of the sender (in this case the iQ Pro server) can be configured in the server software.

Therefore the E-mail address has to be filled in the *Networking* tab of the *iQ Control Server properties* dialogbox

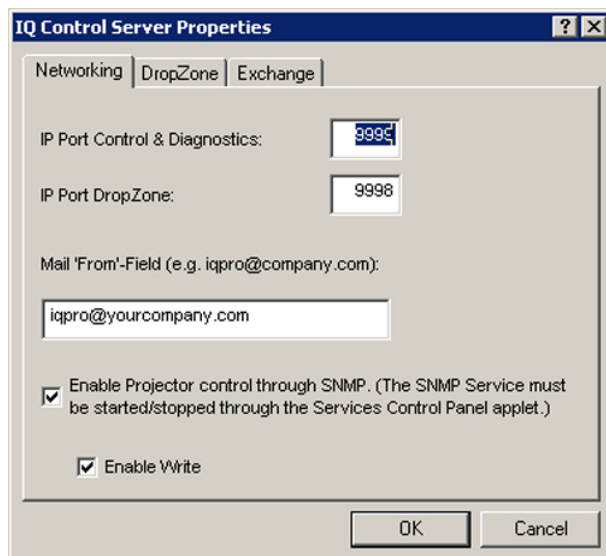

Image 7-52

7.7.3 Projector Firmware Upgrade

What can be done ?

The client software allows to do an upgrade of the projector's firmware.

The upgrade is done with a binary file (extension = “.bin”) which is sent to the projector using the LAN connection.

Single projector as well as multiple projector (group) upgrade is possible

How to upgrade the firmware ?

1. Click on *Configuration* in the toolbar
2. Click on *Upgrade* to open the firmware upgrade screen
See image 7-53.
3. Use the **Browse** key to select the desired **bin** file.

7. IQ Network

4. Press the **Upgrade** button on the browser to select the file to start the operation (image 7-54)
5. Press the **Upgrade** button on the upgrade screen to start the operation
The information screen will show the progress of the operation.

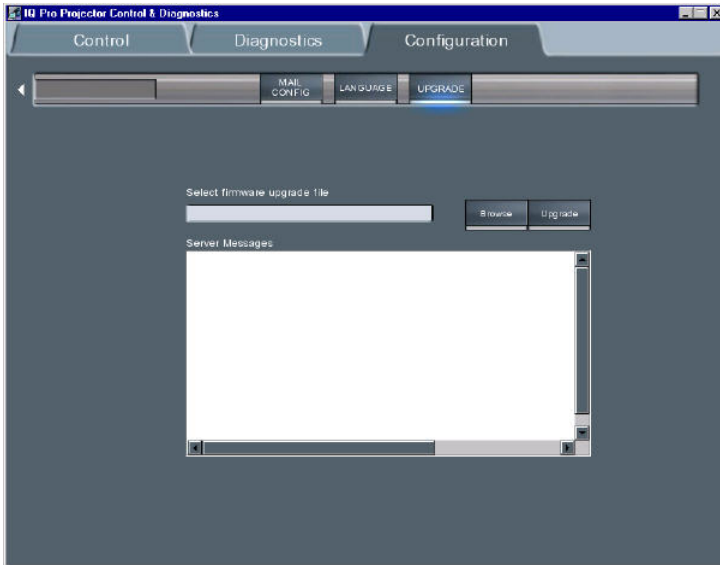

Image 7-53
upgrade interface

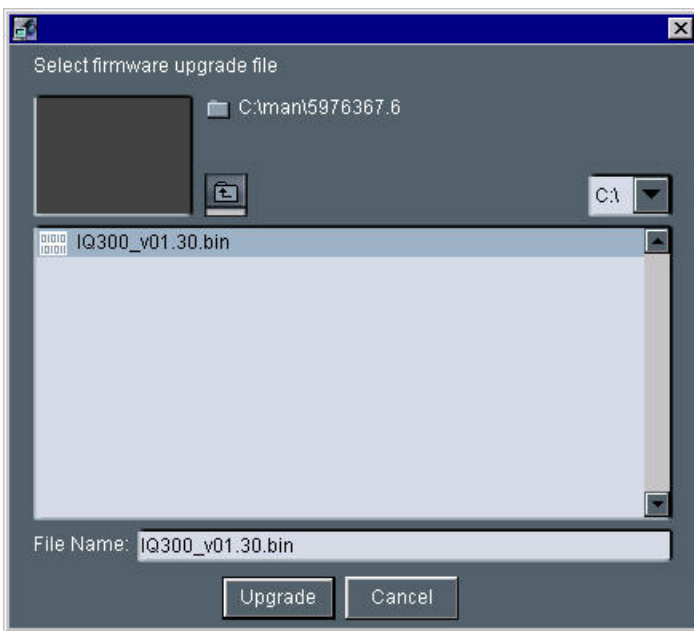

Image 7-54



If the download doesn't succeed please contact Barco

7.8 DropZone

7.8.1 Dropzone tools

What can be done ?

The dropzone interface allows the user to manage (launch, store,...) presentation files from a local desktop.



Image 7-55
the DropZone interface

7.8.2 Start up

Start up

To start using the DropZone one must define the server (projector/display) to connect to. Several situations are possible.

1. The projector/display to connect to has not yet been declared in the DropZone interface, in that case the projector/display has to be added to the DropZone list using the **Add** function.
2. The projector/display to connect to has already been declared in the DropZone, one must then just selected it from the list. In case the projector/display name is not known, there is a possibility to select the projector by its location (only if the location has been specified).

How to open the installation menu ?

1. Click on the arrow to pull down the installation menu. (image 7-56)

See image 7-57.

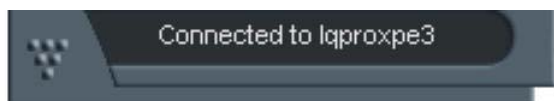

Image 7-56

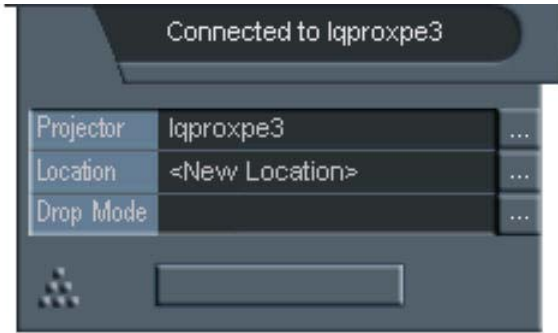

Image 7-57
installation menu

How to add a projector to the list ?

1. Click on the three suspension points to open the projector selection dialog box. (image 7-58)
2. Click on the **Add** button.
A dialogbox is displayed. (image 7-59)
3. Enter the projector name or browse the network.
4. Click on **OK**.
5. Enter the Location (optional).
6. Click on **Connect**.

Following message is displayed : "Connected to <projectorname>..."

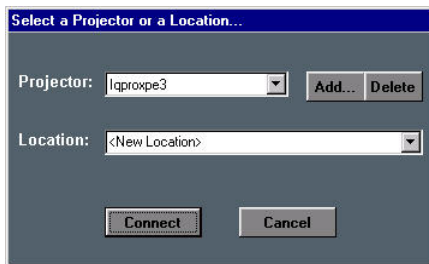

Image 7-58

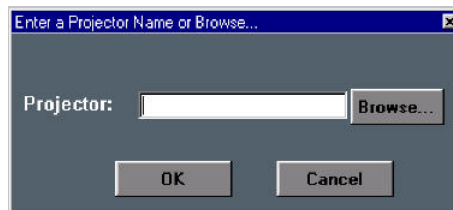

Image 7-59

How to select an existing projector by its name ?

1. Click on the three suspension points to open the projector selection dialog box, image 7-58
2. Open the listbox and select the projector. (image 7-60)
the location will also be filled (if it has been entered previously).
3. Click on **Connect**.

Following message is displayed : "Connected to <projectorname>..."

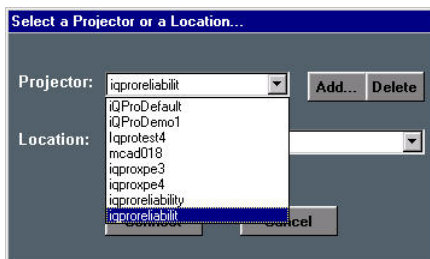

Image 7-60

How to select an existing projector by its location ?

Can be useful when the projector name is not known.

1. Click on the three suspension points to open the projector selection dialog box, image 7-58
2. Open the listbox and select the location. (image 7-61)

The projector name is filled in.

3. Click on **Connect**.

Following message is displayed : “Connected to <projectorname>...”

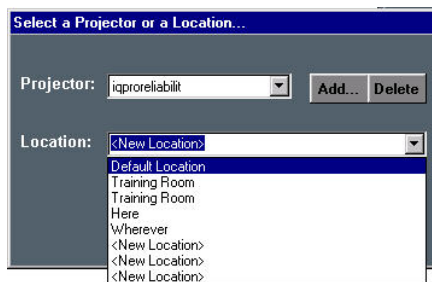

Image 7-61



This is only possible if the location has been filled, the default value for location being “<New Location>”



If the projector is not found following message will be displayed : “Host not found”

If the projector is found but unable to respond (projector disconnected from the network, server software not running, ...) following message will be displayed : “ Host found , but server inactive”

7.8.3 File dropping/launching



Only the Microsoft viewers (PPT, Word, Excel,...) are installed on the projector.

File dropping

Dropping a file means sending it to the projector using the DropZone interface.

The projector can then react in different ways depending on the drop mode selected :

- launch file
- launch file and share
- store file on the projector

File launching

Launch files: a file stored on the projector (server) or on the network can be accessed from a local PC (via the network) or from the projector itself. Launching a file means “sending and starting up” a file (using the required software).

A PowerPoint file can be launched on your PC and projected in another place (by default only the PPT viewer is installed on the projector).



for iQ only : The file will only be projected if the “iQ PC” is selected in the source selection.

How to set the drop mode ?

1. Open the DropZone interface.
2. Click on the arrow to pull down the installation menu.
3. Click on the three suspension points access the drop mode dialog box, image 7-57
See image 7-62.
4. Click on one of the three modes.

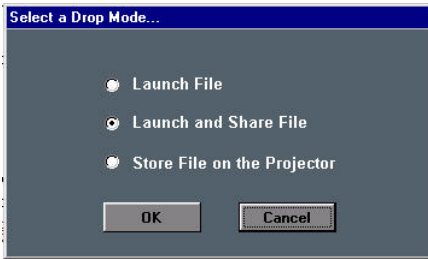

Image 7-62

How to drop a file using the drag method ?

1. Drag the file into the drop window. (image 7-63)
The window opens and shows now the projector. (image 7-64)
2. release the mouse button.
The projector will then process the file according to the setting of the drop mode.



Image 7-63



Image 7-64

How to drop a file using the Open dialog box ?



1. Click on the upper button.
A browser is displayed. Choose a file to send to the projector.
The projector will then process the file according to the setting of the drop mode.

What to do with the launched files once disconnected ?

The previously dropped files are placed in a local directly on the server, one may choose to delete them or not.

1. Click on the arrow to pull down the installation menu.
2. Click on the *Options* button.
A dialog box is displayed. (image 7-65)
3. Check the box to destroy the launched files once disconnected.

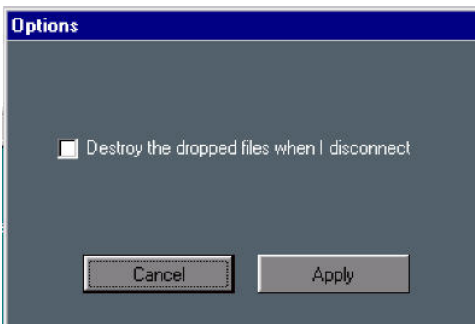

Image 7-65

7.8.4 Open remotely a file on the projector

How to open a file on the projector ?



1. Click on the lower button of the DropZone interface

A browser is displayed. Select the file to be projected.



for iQ only: The file will only be projected if the "iQ PC" is selected in the source selection.

7.8.5 Remote desktop sharing (virtual meeting)

What can be done ?

The remote desktop sharing in the DropZone allows to visualize the projected image i.e. the desktop of the projector PC on a local PC.

Besides **Desktop sharing** one can take the **Control** (mouse and keyboard control) over a presentation (using Netmeeting™). The control over the presentation can be taken or passed at any time.

The configuration consisting of several remote or local meeting participants sharing the same information content is called a **virtual meeting**.

In this **virtual meeting** each meeting participant can participate to the meeting either in a passive way, by following the meeting on his local desktop (remote desktop sharing), or in an active way by controlling the server's desktop (mouse and keyboard).

Control over the desktop can be requested, forwarded or released.

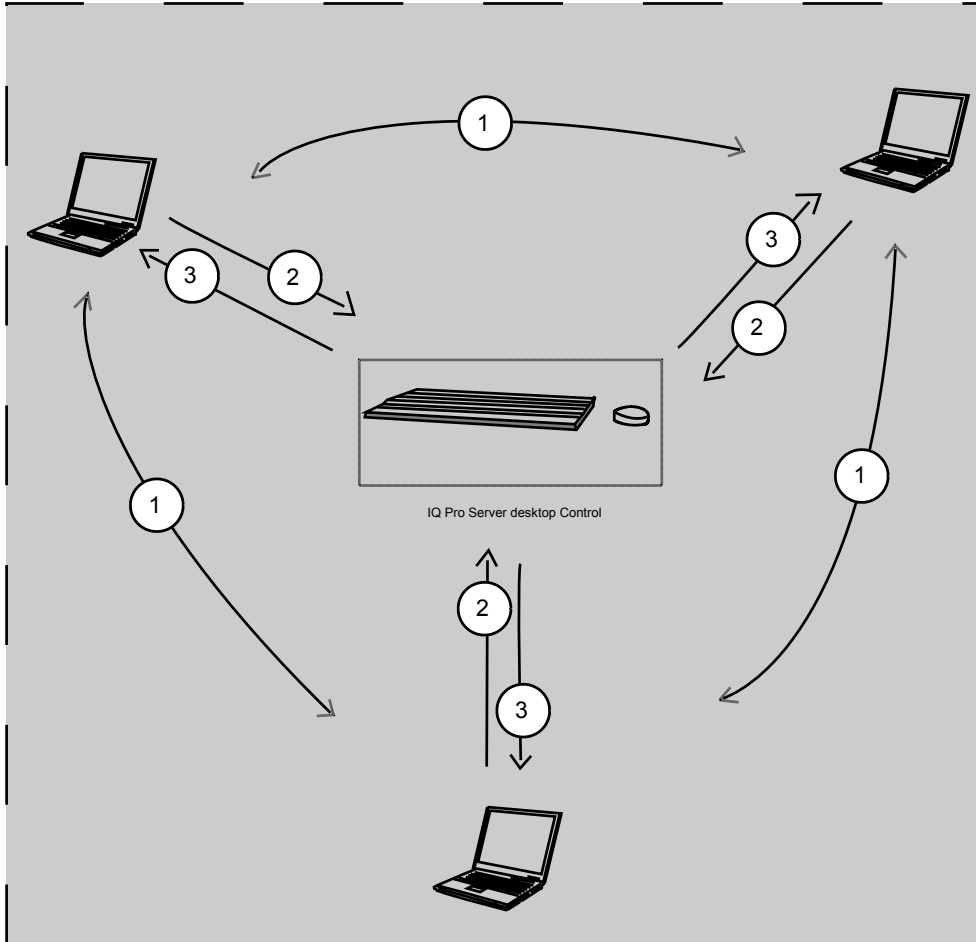



Image 7-66
Virtual Meeting

- 1 forward control
- 2 release control
- 3 request control

How to perform remote desktop sharing ?

- 1. Click on the middle button 

The middle button indicates the activation of the remote 
 The desktop is displayed on the local PC monitor. (image 7-67)

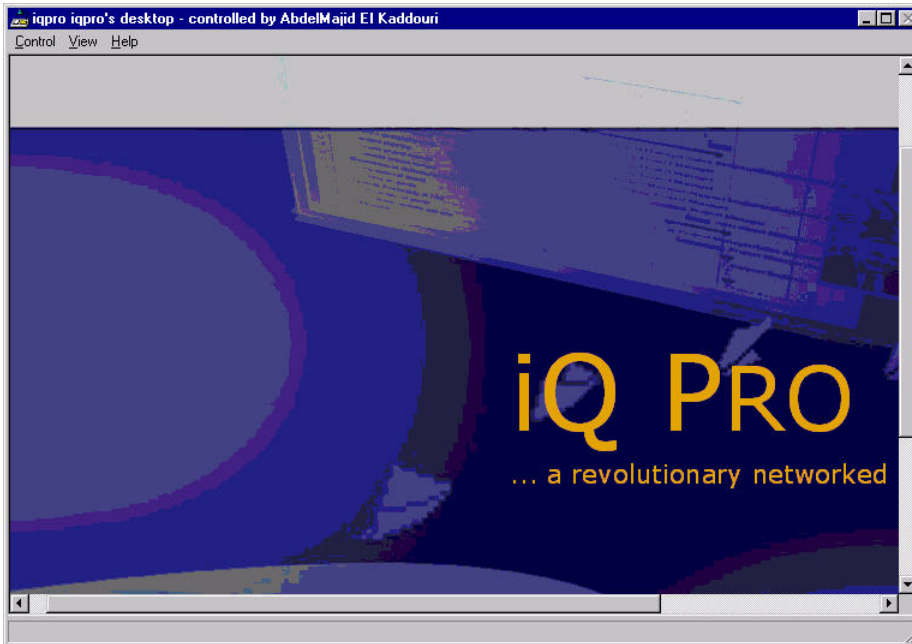

Image 7-67
remote desktop sharing in case of a PowerPoint™ presentation

How to take (mouse and keyboard)Control over the desktop ?

1. Click on the *Control* menu
The *Control* menu is displayed (image 7-68)
2. Select the *Request Control* item
The desktop can now be remote controlled.

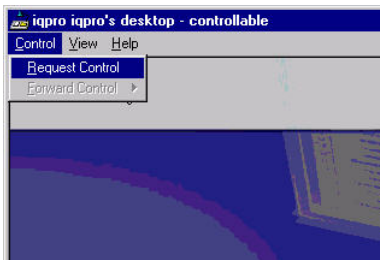

Image 7-68



The control over the desktop is now done by the local PC. However, the user can at any time decide to release or forward the control to someone else.

How to release control over the desktop ?

1. Click on the *Control* menu
The *Control* menu is displayed (image 7-69)
2. Select the *Release Control* item
The desktop remote control can now be requested by someone else.

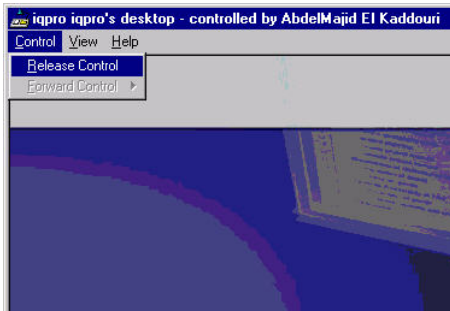

Image 7-69

How to forward control over the desktop ?

1. Click on the *Control* menu

The *Control* menu is displayed (image 7-70)

2. Select the *Forward Control* item

A pop up menu shows the meeting participants i.e. the users which are connected to the server and which participate to the **Remote sharing** of the desktop.

3. Select the meeting participant

The control is transferred and the user which has the control is know indicated in the title bar.

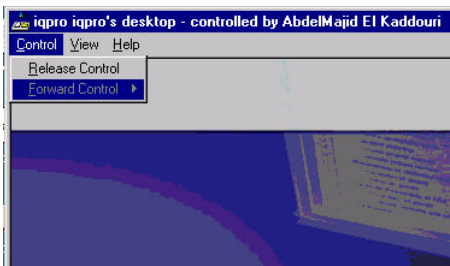

Image 7-70

7.8.6 DropZone settings

What can be done ?

The Server settings on the Projector allow to configure the DropZone in several ways:

- Disallow new meeting participants: New meeting participants will not be able to request desktop sharing or desktop control.
- Disallow Launch file: Launching a file with the DropZone will be impossible when activating this setting, hereby preventing undesired content to be projected during a meeting.
- Enable/disable desktop sharing at startup or logon.

How to setup the DropZone ?

1. Go to the server icon in the lower task bar of the server desktop and Click the right mouse button.

A menu is displayed (image 7-71)

2. Select *Settings*
3. Select the *DropZone* tab (image 7-72)
4. Check the desired settings



Image 7-71

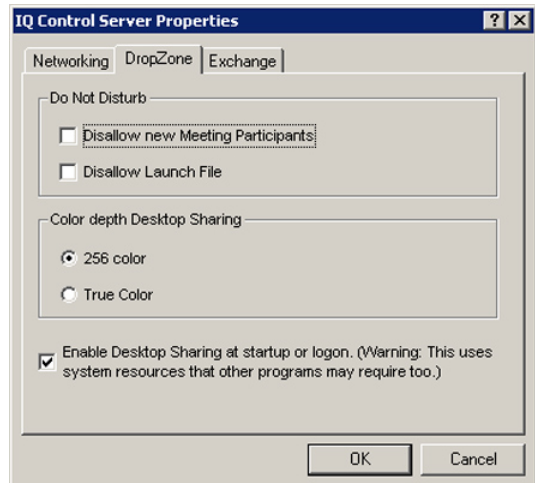

Image 7-72



Choosing *True color* as color depth setting will slow down the communication.



It is advised to leave the other Server properties as they are. If necessary Contact your IT administrator.

7.9 The Web client

Web based functionality

The aim of the web services is to allow each network client within the LAN environment to browse via its internet browser to the web client.

This may be seen as an alternative to the client software since the main control & diagnostic tools are also present. Its advantage resides in the fact that no software has to be installed on the local PC, the internet takes while the html page generation is done locally on the server.

How to access the web client via the internet browser ?

To access the web client, the http link has to be filled in on the client's internet browser.

This http link contains the name of the projector/display i.e. the name under which it is identified within the LAN.

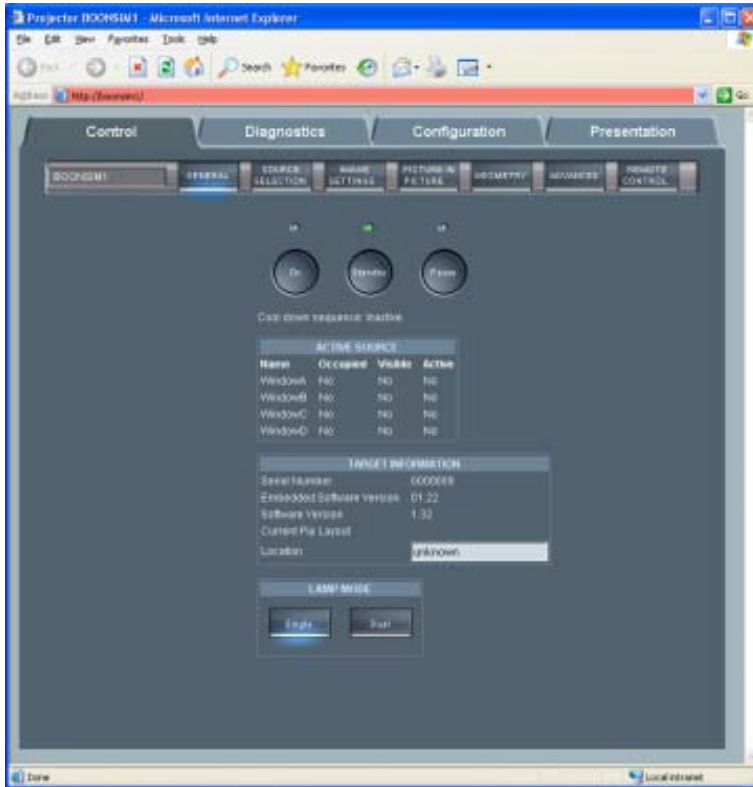

Image 7-73
Web interface

What can be done ?

The possibilities are mainly the same as on the client software.

The web interface allows a user friendly way to manage the projector/display, its use being straightforward and similar to the client interface (ref).

Requirements for the use of the Web client



Some components have to be installed or enabled on your local (client) operating system to allow access to the Web client.

See the Appendix “ General guidelines on network configuration” for general guidelines on how to enable these services. .



The minimal server software version should be V1.10 to allow the use of the Web client.

8. GENERAL GUIDELINES ON NETWORK CONFIGURATION

Overview

- General Network
- The Internet and Web services



The installation of the iQ Pro in a Local Area Network must be done in the same way as the installation of a standard PC in that particular network meaning that the same rules and accepted practice should be respected.

The assistance of qualified IT personnel is advised.

8.1 General Network



An Administrator password has been installed for security reasons (worm and virus protection):

Password : Barco (case sensitive !)

Microsoft NT Domain

To enable access to your network resources, the iQ Pro must be a member of your NT Domain.

This can be configured in the Control Panel, under "System", in the "Computer Name" tab, under the button "Network ID". You'll need some help from the Network Administrator, since you need special rights to do this.

TCP/IP

The iQ Pro uses TCP/IP networking, so it needs the IP address, network mask, broadcast address, gateway, dns, wins, etc. to be configured. This can be done in the Control Panel, under "Network Connections". This can however be configured automatically, if your network uses DHCP.

8.2 The Internet and Web services

Internet access

If you want to access the Internet from the iQ Pro, and the projector is located behind a firewall, you will also need to configure the proxy to use. This can be done in the Control Panel, under "Internet Options", in the tab "Connections", under the button "LAN Settings".

iQ Pro Web services

To use the iQ Pro web client, you might need to change the "LAN Settings" on your local computer

If the client thinks the projector is on the Internet, and tries to connect to it through the proxy, you can turn on the "Bypass proxy server for local addresses" feature, or add the projector to the Exceptions list under the "Advanced" button.

The "Internet Information Services(IIS) " component has to be installed on the operating system.

SNMP

To enable management via the IQProSNMP Agent, you must enable the SNMP system service, and configure the communities accordingly.

This can be done in the Control Panel, under Administrative Tools, in the Services, under the entry "Management and Monitoring tools". You may also need to enable SNMP in the iQ Pro Control Server in the system tray, see image below.

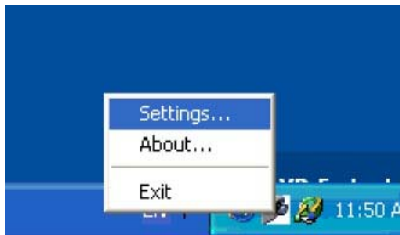

Image 8-1
system tray

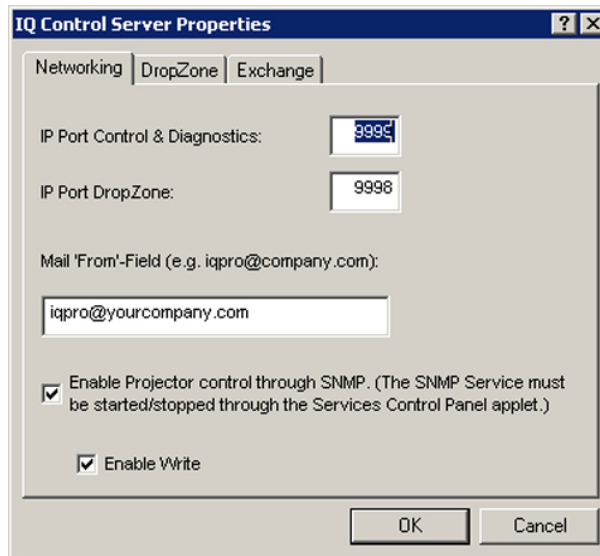

Image 8-2
server settings dialog box



For more info, see "SNMP services", page 155

Microsoft Exchange and Outlook

To enable control via the Microsoft Exchange integration, you need to install, enable and configure the IQProEXCH module.

To enable control from Microsoft Outlook, you need to install, enable and configure the IQProEXCH module, and install an Outlook Form on the Exchange Server in your network.



For more info, see "Exchange", page 147

9. EXCHANGE

Introduction

Some parameters values are installation dependent, and are shown here as an example.

You may need assistance from you network administrator, IT Manager or MIS helpdesk to obtain the settings or to configure the projector for you, since this is a task description targeted to 'Administrators' and needs knowledge and/or permissions normally held by those persons.

It is advised that you first try to follow the procedure to obtain a working setup, before changing the settings for conforming to your local security requirements.

Use of this software requires a working Microsoft Exchange server installed somewhere in your corporate network.

9.1 Exchange Installation

9.1.1 Installation procedure

Creating a user account and mailbox

1. Create a user account in your NT Domain (on the projector).
The service will use this account to log on to the domain, and as credentials to authenticate to Microsoft Exchange to read the entries in the Calendar folder of the Mailbox.
Username: iqpro
Domain: BARCO
Password: pwiqpro
2. Create a Mailbox for the projector's account on the Microsoft Exchange Server (on your LAN).
The NT Domain user created in step 1 should have read access to this Mailbox.
Server: "BARCOEXCHSRV"
Mailbox: "Projector, IQPRO"
User: BARCO\iqpro

Installing and configuring Microsoft Outlook (on the projector)

1. Install Microsoft Outlook on the Projector.
Note: *To be able to access Microsoft Exchange, you need a Client Access License.*
Once you have one of those, you also have a license to Microsoft Outlook.
Refer to the following URL for more information: http://www.microsoft.com/resources/sam/licensing/cal_guide/exchange.asp
Tip: *Outlook can be installed from the Microsoft Exchange Server CDROM or from a Microsoft Office Suite Installation CDROM.*
Since the IQ Pro has no CDROM drive, you may need to use a CDROM drive shared from a PC in the network.
Alternatively, you could use a USB CDROM drive.
2. Make sure the projector is part of the domain
Tip: *This can be done in Control Panel->System->Computer Name->Change*
3. Log in on the projector as the user
User: iqpro
Domain: BARCO
Password: pwiqpro
Tip: *If the user cannot log on, the Local Administrator should add the right "Log on locally" for the user.*
This must be configured in Start->Control Panel->Administrative Tools->Local Security Policy
4. Configure Outlook
Profile Name: "MS Exchange Settings"
This is what the wizard proposes by default, and what is used in this document.
Default Mail Client: yes
Note: *Make sure that MS Outlook is the default Mail Client for this account.*
You can do this afterwards from this configuration page: Start->Control Panel->Internet Options->Programs->Email For more information, refer to :
<http://www.microsoft.com/mspress/troubleshooting/outlook/LS/101801.asp>

Enabling the account

1. Log on to the projector as an Administrator for the next steps.

9. Exchange

For security reasons, you will probably not want to make the projector account part of one of the administrator groups.

2. Enable the account to be used by the "iQ Pro Exchange Integration" service
3. In the Tree of the "Local Security Settings" application, navigate to Security Settings->Local Policies->User Right Assignment.
4. In the List, edit the "Log on as a service", and add the account, in the example "BARCO\iqpro".

Installing and configuring the iQProEXCH service

Step 1,2,3 refers to the manual installation. One can use the SETUP.EXE program instead.

1. Copy the file IQProEXCH.EXE to (eg.) C:\Program Files\BARCO\iQ Pro Server
2. Open a command line, and go to the that directory
3. Type the following command IQProEXCH /Service
4. To configure, right click the "iQ Pro Server" tray icon, and go to the tab "Exchange"
Enter the credentials (image 9-1, image 9-2)
5. To enable the "iQProEXCH" service go to Control Panel->Administrative Tools->Services->iQPro Exchange
go to the TAB "General Startup" and Type: Automatic
Make the service use the correct account TAB Log On
Select "Local System Account"
Check "Allow service to interact with desktop"
6. Start the service, or reboot the projector.

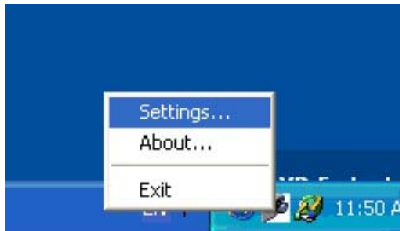

Image 9-1
system tray



Image 9-2
server exchange tab



You should now be able to schedule commands from a Microsoft Exchange client such as Outlook running on any computer on the local network, provided you have the necessary permissions on the Calendar in the projector mailbox.

9.1.2 Troubleshooting



The file C:\Program Files\BARCO\iQ Pro Server\iQProEXCH.log and the "Event Log" may contain helpful information to diagnose what's going wrong

What can go wrong and what to do ?

1. The log file contains "**Logon failure: unknown user name or bad password**"
Check Username, Password and Domain in Control Server/Exchange
2. The log file contains "**Logon failure: the user has not been granted the requested logon type at this computer.**"
The user account must be given the "**Log on as a service**" permission. This is done in Start/Control Panel/Administrative Tools/ Local Security Settings/Security Settings/Local Policies/User Right

- Assignment. In the list, add the user to the entry "**Log on as a service**"
3. The log file contains "**Could not log on with Profile 'MS Exchange Settings'**" Make sure the profile exists. To check this, log in to the projector as the user (BARCO\iqpro), as the profile should be owned by the projector account, and Outlook-profiles are per-account. Start/Control Panel/Mail
 4. The user cannot log on to the projector. The Administrator should add the right "**Log on locally**" for the user. This must be configured in the Start/Control Panel/Administrative Tools/Local Security Policy
In the list, add the user to the entry "**Log on as a service**"
 5. When trying to start the service, the projector beeps, and the service stays in the 'starting' state
This happens when the service tries to display an error in a popup, but cannot access the desktop. Control Panel/Administrative Tools/Services/IQPro Exchange
Check "**Allow service to interact with desktop**"
You may need to end the process 'IQProEXCH' from the task manager.
 6. The commands are not executed at the right time
Check the time of the computer and the timezone Start/Control Panel/Date and Time/Timezone
 7. An Outlook dialog box is displayed stating that there is no default mail client.
Make sure that MS Outlook is the default Mail Client for this account. You can do this from this configuration page: Start/Control Panel/Internet Options/Programs/Email
You may need to do this as administrator, since the service is started as 'Local System' account.
Tip: For more information, refer to <http://www.microsoft.com/mspress/troubleshooting/outlook/LS/101801.asp>

9.2 Exchange Integration

Introduction

The projector must be configured to connect to a mailbox on a Microsoft Exchange server in the network, which is dedicated to the projector, and to which of course the projector has rights to connect to.

The commands should be put in the SUBJECT of an appointment in the Exchange Calendar of the projector. The Start Time and End Time of the appointments are used for timing info. The other fields (location, categories, body, ...) are not used by the software, and thus can be used to store extra information for the USERS of the projector mailbox.

9.2.1 Command

How are the commands build up ?

- Command **filename/filepath**

The parameter **filename** is a filename relative to the "Receive" directory of the iQ Pro Control Server, which, in a default installation, would typically be the local folder "C:\Documents and Settings\All Users\Received" The parameter **filepath** is an absolute path to a file.

The commands should be put in the SUBJECT of an appointment in the Exchange Calendar of the projector. This is a mailbox on a Microsoft Exchange server in the network, which is dedicated to the projector, and to which of course the projector has rights to connect to.



The command and the filename are separated by a space.

Overview of the commands

- ON
- STANDBY
- PAUSE
- PAUSE ON
- PAUSE OFF
- LOGO
- LOGO ON
- LOGO OFF
- SWITCH SOURCE
- SWITCH LAYOUT
- LAUNCH ATTACHMENT
- STORE ATTACHMENT
- STORE **filename**
- STORE FILE **filepath**
- LAUNCH **filename**
- LAUNCH FILE **filepath**
- DELETE **filename**
- DELETE FILE **filepath**

ON, STANDBY

The projector is put in the specified state at the beginning of this event. Beware that if the SBC (Single Board Computer) is to be powered-down during STANDBY, that further events will not be processed, since the integration runs on that SBC.

PAUSE, LOGO

The projector is put in the specified state at the beginning of this event, and the state is undone at the end of this event. o A parameter ON or OFF can be specified to choose between the actions. This action will then be executed at the beginning. So "PAUSE from 12:00 to 13:00" is equivalent to "PAUSE ON at 12:00" + "PAUSE OFF at 13:00"

SWITCH SOURCE, SWITCH LAYOUT

The projector switches source or layout at the beginning of this event.

LAUNCH ATTACHMENT

The attachment is saved at the beginning of this event. Then the associated application is started. o At the end of the event, the application is killed. This can not be guaranteed if the application was already running on the projector. For example, if a web page is being displayed, and a second one is launched, the application is not started, but the original browser displays the page. In this case the second event can not control the browser. This is a limitation of the Windows platform.

STORE ATTACHMENT

The attachment is saved at the beginning of this event. The name of the attachment is used and the file is placed in the Receive folder.

STORE filename

The attachment is saved at the beginning of this event. The name filename is used and the file is placed in the Receive folder. For example "STORE MYFILE.PPS" will save the attached file to "C:\Documents and Settings\All Users\Received\MYFILE.PPS"

STORE FILE filepath

The attachment is saved at the beginning of this event. The path filepath is used as absolute filename. For example, the command "STORE FILE C:\My Videos\MYFILE.AVI" will store the attachment as C:\My Videos\MYFILE.AVI. This of course if permissions are correct and the directory C:\My Videos exists

DELETE filename

The file with name filename is deleted from the receive folder. For example "DELETE MYFILE.PPS" will delete "C:\Documents and Settings\All Users\Received\MYFILE.PPS"

DELETE FILE filepath

The file with absolute name filepath is deleted. For example, the command "DELETE FILE C:\My Videos\MYFILE.AVI" will store the attachment as C:\My Videos\MYFILE.AVI.

Drop down list

Besides the above commands some predefined commands can be selected from a drop down list in the iQPro tab.



Image 9-3

9.2.2 Example

Schedule projector tasks in Microsoft Outlook 2000

following tasks are scheduled:

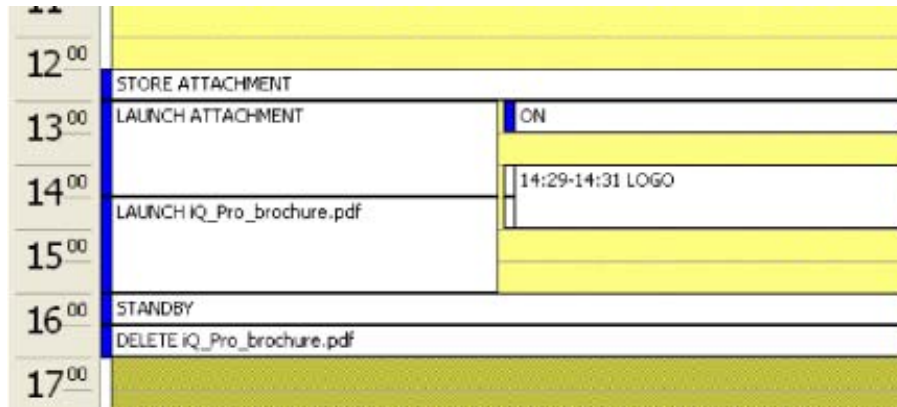

Image 9-4

1. store attachment at 12:30 (The attached file is iQ_Pro_brochure.pdf)
2. turn the projector on at 13:00 and launch a different attached file
3. show the logo from 14:29 to 14:31 to hide the killing of the application and the starting of the PDF Viewer
4. at 14:30, launch the PDF file that was stored in step 1
5. kill the application and put the projector in standby at 16:00
6. delete the PDF file that was stored in step 1

9.2.3 Microsoft Outlook Integration

Adding Outlook forms

To make things easier for users, you can install an Outlook Form that adds a tab called "iQ Pro" to the appointment. The form contains the most-used commands in easy-to-use drop-down lists. It looks as follows:

9. Exchange

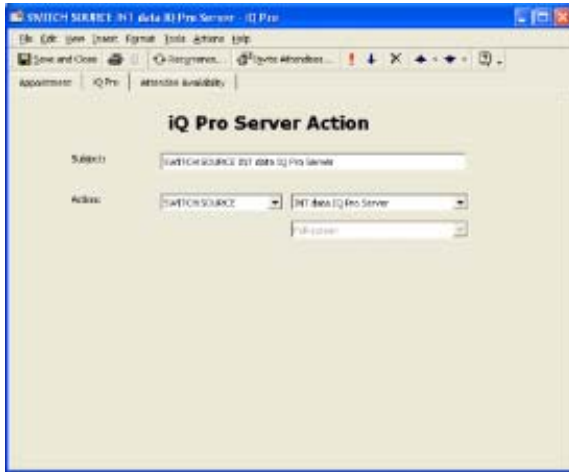

Image 9-5

The form contains the functionality that a normal user should be able to use without consulting the documentation.

The attachments, date and time fields must be edited in the "Appointment" tab.

Choosing items from the drop-down boxes fills in the subject.

By default, the layouts "Full-screen" and "2by2 raster" are defined in the form.

If you add layouts on the projector(s) or change the defaults, the user must type the name of the layout in the subject.

The form can be modified to make things easier for users, one can also add the defined layouts to the drop-down list. This must be done from Outlook, in the menu "Tools->Forms->Design This Form"

Organizational Forms



The administrator should install Organizational Forms on the Exchange Server in the "Organizational Forms" library.

Default form

Now the form still needs to be set as a default for creating new items. When returning to the "Forms" tab in the "Calendar Properties" you should now see the "iQ Pro" template installed. Now go to the "General" tab and select the template as default for posting to the folder.



Image 9-6

If the form was installed as an "Organizational Form", you need to select the "Forms..." entry, which will display the "Choose Form" dialog,

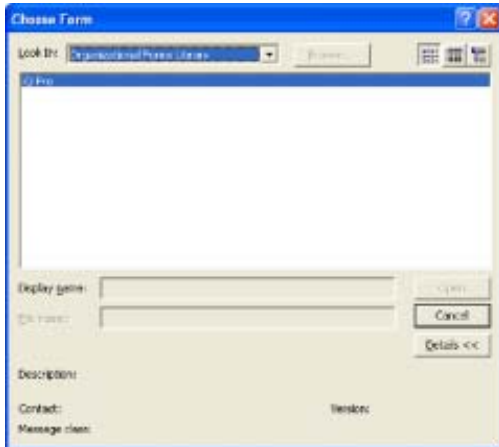

Image 9-7

9.2.4 Folder form

Folder form

Alternatively, the form can be installed for the Calendar folder only, by following the procedure described below

How to configure a folder form

1. In Outlook, right-click on the "Calendar" icon in the "Outlook Shortcuts" tab in the "Outlook Bar" to open the "Properties" page, while logged-on as the projector (Or display the "Folder List", and right-click the "Calendar" folder to open the "Properties" page).
2. In the "Calendar Properties" dialog, go to the "Forms" tab, and click the "Manage..." button. (image 9-8)
3. On the "Forms Manager" dialog, click the "Install..." button and select the file "iQ Pro.fdm". (image 9-9)
4. When returning to the "Forms" tab in the "Calendar Properties" you should now see the "iQ Pro" template installed. Now go to the "General" tab and select the template as default for posting to the folder. (image 9-10)



Image 9-8



Image 9-9

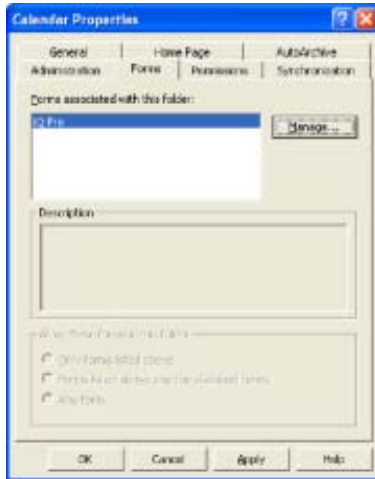

Image 9-10

9.2.5 Limitations and known “problems”

Overlapping tasks

When launching 2 attachments with overlapping times it is possible for the application to exit at the end of the first period. For example, let's say we try to display PRES1.PPT from 12:00 to 13:30, and PRES2.PPT from 13:00 to 14:30, it is possible for BOTH presentations to exit at 13:30. This is because Windows uses the same process to display both files, and activates them via DDE.

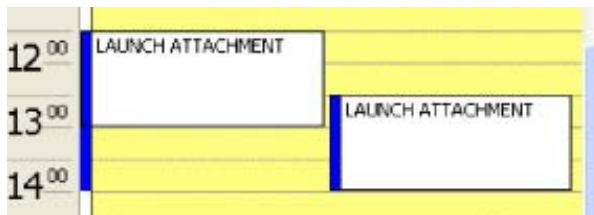

Image 9-11



This is a limitation in the Microsoft Windows ShellExecuteEx API



Avoid overlapping schedules in this case, or change the associations in: My Computer->Tools->Folder Options->File Types->(extension)

Try to disable DDE (under Edit with the default action, eg 'open', selected) and/or disable 'Browse in same window' or using a different viewer/player for the file type.

10. SNMP SERVICES

Introduction

Some parameters values are installation dependent, and are shown here as an example.

You may need assistance from you network administrator, IT Manager or MIS helpdesk to obtain the settings or to configure the projector for you, since this is a task description targeted to 'Administrators' and needs knowledge and/or permissions normally held by those persons.

It is advised that you first try to follow the procedure to obtain a working setup, before changing the settings for conforming to your local security requirements.

10.1 SNMP installation

Introduction



The Control Server version should be at least version 1.10.

To check the version, open the about box from the server tray:



Software updates can be obtained from the BARCO support website: ftp://ftp.barco.com/pub/iq_pro_software/ or from secured website PartnerZone

How to install SNMP (only if necessary)

1. The Microsoft SNMP service must be installed
You may need to install this service from the Windows XP CDROM.
2. Install the SNMP Agent Extension dll **regsvr32 IQProSNMP.dll**
The agent should now be registered as "iqpro" under
HKEY_LOCAL_MACHINE\SYSTEM\CurrentControlSet\Services\SNMP\Parameters\ExtensionAgents

How to configure SNMP (only if necessary)

1. Go to the Control panel, under the Administrative Tools, in the Services, in the "SNMP" entry.
2. In the "General" tab, you can enable the service, and make it start automatically.
3. In the "Security" tab, the default Community is called 'public' and is read-only.
You may want to give read-write permission to 'public' (not recommended) or create a 'private' community with read-write permissions.
4. In the Control Server, enable the SNMP support, and optionally, enable read-write support.
5. The SNMP service should be restarted, to take the changed settings into account.



To uninstall the snmp agent: **regsvr32 /u IQProSNMP.dll**

10.2 SNMP integration

Commands

Following commands are provided stored in the MIB :

Command	Type
PROJECTORTYPE	READ
SERIALNUMBER	READ

Command	Type
LAMPPRODUCTNUMBER	READ
LAMPSERIALNUMBER	READ
SERVERTYPE	READ
SERVERVERSION	READ
EMBEDEDSOFTWAREVERSION	READ
PROJECTORLANGUAGE	READ
PROJECTORNAME	READ
LOCATION	READ
ORIENTATION	READ
RESOLUTION	READ
DESKTOPRESOLUTION	READ
PROJECTORSTATE-cooldown	READ
PROJECTORSTATE-textbox	READ
PROJECTORSTATE-projector	READ/WRITE
PAUSE	READ/WRITE
FREEZE	READ/WRITE
PROJECTORRUNTIME	READ
LAMPWARNINGSTATUS	READ
LAMPALERTSTATUS	READ
LAMPMODE	READ/WRITE
LAMPRUNTIME	READ
LAMPSTATUS	READ
LAMPWARNINGTIME	READ/WRITE
I2CDIAGNOSTICS	READ
POWERSUPPLYERROR	READ
LAMPERROR	READ
PCSTATEPROJECTORON	READ/WRITE
PCSTATEPROJECTORSTANDBY	READ/WRITE
PCSTATE	READ/WRITE

11. STANDARD IMAGE FILES

11.1 Table overview

Table overview

The following standard image files are pre-programmed in the projector.

Name ⁵	Resolution ⁶	Fvert Hz ⁷	FHor kHz ⁸	Fpix MHz ⁹	Ptot ¹⁰	Pact ¹¹	Ltot ¹²	Lact ¹³
1600_48V	1600x600i	48,040	62,500	135,000	2160	1600	651	600
CGA	640x200i	59,924	15.700	14.318	912	640	262	200
COMPUSC4	1024x480i	29,945	30,694	39,779	1296	1024	512	480
DOS1_70	720x400	70	31,500	28,350	900	720	449	400
DOS3_56	640x400	56	24,800	21,030	848	640	440	400
DOS4_85	640x400	85	37,860	31,500	832	640	445	400
ED	735x480	59,943	31,470	28,638	910	735	525	480
EGA	640x350	59,702	21,851	16,257	744	640	366	350
ESVGA_75	832x624	73	47,900	53,648	1120	832	660	624
EXGA_60	1152x864	60	54,900	79,934	1456	1152	916	864
EXGA_80	1152x864	80,000	76,499	110,159	1140	1152	958	864
EXGA_85	1152x864	85 ,000	77,202	121,671	1576	1152	907	864
EXGA1_70	1152x864	70	63,800	94,424	1480	1152	912	864
EXGA1_75	1152x864	75	67,499	107,999	1600	1152	900	864
EXGA2_70	1152x864	70	66,098	99,941	1512	1152	945	864
EXGA2_75	1152x864	75	75,199	110,092	1464	1152	1002	864
FMR	640x400i	42,323	36,440	28,570	784	640	431	400
GE_50	640x400	50	31,200	44,928	1440	1163	625	522
GE_60	1085x480	60	30,700	41,261	1344	1085	512	480
hd_1080i	1920x540	60	33,750	74,249	2200	1920	563	540
hd_24p	1920x1080	24,000	27,000	74,000	2750	1920	1125	1080
hd_24sf	1950x540	48,000	27,000	74,000	2750	1950	562	540
hd_25i	1920x540	50,000	28,125	74,000	2640	1920	562	540
hd_25p	1920x1080	25,000	28,125	74,000	2640	1920	1125	1080

5. Name: name of file, contains the settings.

6. Resolution: image resolution, when followed by ..i means interlaced.

7. Fvert Hz: vertical frame frequency of the source

8. FHor kHz: horizontal frequency of the source

9. Fpix MHz: pixel frequency

10. Ptot : total pixels on one horizontal line.

11. Pact: active pixels on one horizontal line.

12. Ltot: total lines in one field

13. Lact: active lines in one field.

11. Standard Image Files

Name ⁵	Resolution ⁶	Fvert Hz ⁷	FHor kHz ⁸	Fpix MHz ⁹	Ptot ¹⁰	Pact ¹¹	Ltot ¹²	Lact ¹³
hd_30p	1920x1080	30,000	33,750	74,000	2200	1920	1125	1080
hd_60p	1280x720	60,000	45,000	74,000	1650	1280	750	720
INTER_GR	1184x886	67,170	61,796	92,941	1504	1184	920	886
IQPC_SXGA_2	1366x1024	59	62,933	106,230	1688	1366	1067	1024
IQPC_SXGA_D	1280x1024	60	63,857	107,791	1688	1280	1063	1024
IQPC_XGA_1	1024x768	61	49,005	65,863	1344	1024	807	768
IQPC_XGA_2	1024x768	60	48,485	65,164	1344	1024	807	768
IQPC_XGA_D	1024x768	61	49,005	65,863	1344	1024	806	768
MAC_3	512x384	60,147	24,480	15,667	640	512	407	384
MAC_4	560_384	60,147	24,480	17,234	704	560	407	384
MAC_5	512x342	60,158	22,259	16,670	704	512	370	342
MAC_6	832x624	74,546	49,722	57,280	1152	832	667	624
MAC_7	1024x768	74,907	60,150	80,000	1330	1024	803	768
MAC_LC	640x480	66,619	34,975	31,338	896	640	525	480
MAC_POR	640x870	74,996	68,846	57,280	932	640	918	870
METH_BOOT1	720x400	70	31,500	28,350	900	720	448	400
METH_BOOT2	640x480	59	31,000	24,800	800	640	524	480
MXGA_100	1152x864	100	92,997	145,820	1568	1152	930	864
NTSC	675x240	60	15,748	13,512	858	675	263	240
NTSC_LIMO_x2	834x482	60	31,496	32,252	1024	834	525	482
NTSC_LIMO_x3	834x715	60	46,646	47,766	1024	834	778	715
NTSC_LIMO_x4	834x961	60	62,992	64,504	1024	834	1050	961
PAL	675x286	50	15,625	13,500	864	675	313	286
PAL_LIMO_x2	834x574	50	31,250	32,000	1024	834	626	574
PAL_LIMO_x3	834x850	50	46,296	47,407	1024	834	926	850
PAL_LIMO_x4	834x1146	50	62,500	64,000	1024	834	1250	1146
PAM500	640x400	60,000	26,400	22,810	864	640	440	400
PAM800	1120x375i	44,936	36,443	50,000	1372	1120	406	375
PC98_2	1120x375i	39,994	32,835	47,840	1457	1120	411	375
PC98_3	1120x750	60,000	50,000	78,569	1571	1120	833	750
S1152_66	1152x900	66,004	61,846	94,500	1528	1152	937	900
S1152_76	1152x900	76,637	71,809	108,000	1504	1152	937	900

Name ⁵	Resolution ⁶	Fvert Hz ⁷	FHor kHz ⁸	Fpix MHz ⁹	Ptot ¹⁰	Pact ¹¹	Ltot ¹²	Lact ¹³
S1600_67	1600x1280	67	89,286	200,000	2240	1600	1334	1280
SDI_625	675x278i	25,000	15,625	13,500	864	720	313	278
SDI_525	675x240i	29,970	15,734	13,500	858	720	263	240
SG_50	1600x1200	50,000	62,500	130,313	2085	1600	1250	1200
SG_60_1	1280x1024	60,000	63,900	107,352	1680	1280	1065	1024
SG_60_2	1024x768	60,000	48,780	64,390	1320	1024	813	768
SG_60_3	960x680	60,000	43,200	54,432	1260	960	720	680
SG_60_4	1600x1200	60,000	75,000	156,375	2085	1600	1250	1200
STOR_100	764x287	100	31,300	30,361	970	764	313	287
STOR_120	810x247	119	31,300	30,361	970	810	263	247
STOR_50	1024x512	50	31,300	40,064	1280	1024	625	512
STOR_60	1024x512	60	31,300	40,064	1280	1024	525	512
SUNNEWS67	1280x1024	67,189	71,691	117,000	1632	1280	1067	1024
SUNNEWS76	1280x1024	76,107	81,130	135,000	1664	1280	1066	1024
SUNXGA60	1024x768	59,984	48,287	64,125	1328	1024	805	768
SUNXGA70	1024x768	70,041	56,596	74,250	1312	1024	808	768
SUNXGA77	1024x768	77,069	62,040	84,375	1360	1024	805	768
SUP_MAC	1024x768	60,000	48,780	63,999	1312	1024	813	768
SVGA_56V	800x600	56,250	35,156	36,000	1024	800	625	600
SVGA_60V	800x600	60,317	37,879	40,000	1056	800	628	600
SVGA_72_1	800x600	72,084	48,080	50,003	1040	800	666	600
SVGA_72_2	800x600	72,084	48,080	50,003	1040	800	667	600
SVGA_75	800x600	75,000	46,875	75,000	1056	800	625	600
SVGA_85	800x600	85,000	53,635	56,250	1048	800	631	600
SXGA_72_1	1280x1024	72	76,699	128,854	1680	1280	1061	1024
SXGA_72_2	1280x1024	72	76,970	130,080	1690	1280	1069	1024
SXGA_75	1280x1024	75	79,974	134,997	1688	1280	1066	1024
SXGA_76	1280x1024	76	81,103	134,955	1664	1280	1066	1024
SXGA_85	1280x1024	85	91,149	157,506	1728	1280	1072	1024
SXGA_L	1280x1024	60	62,500	84,000	1344	1280	1041	1024

11. Standard Image Files

Name ⁵	Resolution ⁶	Fvert Hz ⁷	FHor kHz ⁸	Fpix MHz ⁹	Ptot ¹⁰	Pact ¹¹	Ltot ¹²	Lact ¹³
SXGA+_60	1280x1024	60	63,980	107,997	1688	1280	1066	1024
SXGA2_60	1280x960	60	59,999	107,998	1800	1280	1000	960
SXGA2_85	1280x960	85	85,940	148,505	1728	1280	1011	960
SXGA50	1280x1024	50	52,351	88,368	1688	1280	1047	1024
SXGA60v	1280x1024	60	63,658	110,001	1728	1280	1056	1024
SXGAP_70	1024x1280	70	92,902	133,779	1440	1024	1326	1280
SXGAP1_60	1024x1280	60	77,700	83,916	1080	1024	1297	1280
SXGAP2_60	1024x1280	60	79,498	110,661	1392	1024	1325	1280
UXGA_60	1600x1200	60	75,002	162,004	2160	1600	1250	1200
UXGA_65	1600x1200	65	81,248	175,496	2160	1600	1250	1200
UXGA_70	1600x1200	70	87,497	188,993	2160	1600	1250	1200
UXGA_75	1600x1200	75	93,747	202,494	2160	1600	1250	1200
UXGA_85	1600x1200	85	106,247	229,494	2160	1600	1250	1200
UXGA_L	1600x1200	60	72,801	119,977	1648	1600	1216	1200
UXGAP1_60	1200x1600	59	95,804	119,946	1252	1200	1620	1600
UXGAP2_60	1200x1600	60	99,404	163,817	1648	1200	1656	1600
VGA_60	640x480	60	31,326	25,061	800	640	525	480
VGA_66	640x480	67	35,100	30,326	864	640	525	480
VGA_72	640x480	73	37,860	31,500	832	640	520	480
VGA_75	640x480	75,000	37,500	31,500	840	640	500	480
VGA1_85	640x480	85,000	43,369	36,000	832	640	509	480
VGA2_85	720x400	85,000	37,900	35,475	936	720	446	400
VGA75ISO	640x480	75,000	39,375	31,500	800	640	525	480
VIDEO525	1302x239i	29,970	15,734	32,207	1302	1024	263	239
VIDEO625	1024x278i	25,000	15,625	31,984	1310	1024	313	278
XGA_43	1024x384	87	35,500	44,872	1264	1024	409	384
XGA_60	1024x768	60,000	48,360	64,996	1344	1024	806	768
XGA_70_1	1024x768	70,000	56,475	74,999	1328	1024	806	768
XGA_70_2	1024x768	70,000	57,052	78,047	1368	1024	815	768
XGA_72	1024x768	71,955	58,140	80,000	1376	1024	808	768

Name ⁵	Resolution ⁶	Fvert Hz ⁷	FHor kHz ⁸	Fpix MHz ⁹	Ptot ¹⁰	Pact ¹¹	Ltot ¹²	Lact ¹³
XGA_75_1	1024x768	75	60,024	78,752	1312	1024	800	768
XGA_75_2	1024x768	76	61,080	86,000	1408	1024	806	768
XGA_85	1024x768	85,000	68,680	94,500	1376	1024	808	768
XGA_EOS	1024x768	63,000	50,000	67,200	1344	1024	796	768
XGA75_GS	1024x768	74,534	59,701	79,284	1328	1024	801	768
SXGA_60	1280x1024	60	63,980	107,997	1688	1280	1066	1024
SXGA+_60_2	1400x1050	60	65,574	122,230	1864	1400	1089	1050
SXGA+_60_3	1400x1050	60	65,104	122,396	1880	1400	1085	1050

Table 11-1

12. TROUBLESHOOT

12.1 Using the OSD

What can be done ?

The projector bus allows the diagnostic of different hardware components divided in two main groups.

- I²C diagnostics : a number of internal electronic boards can be diagnosed and a graphical interface shows whether an error is
- Lamps and power supply : lamp temperature and power related failures are logged and can be checked at any time.

How to display the I²C diagnostics menu ?

1. Press **MENU** to activate the Tool bar
2. Press → to select the *Tools* item
3. Press ↓ to Pull down the *Tools* menu
4. Use ↑ or ↓ to select *Diagnostics*
5. Press → to pull down the menu
6. Press **ENTER** to select I²C (image 12-1)

A text box is displayed

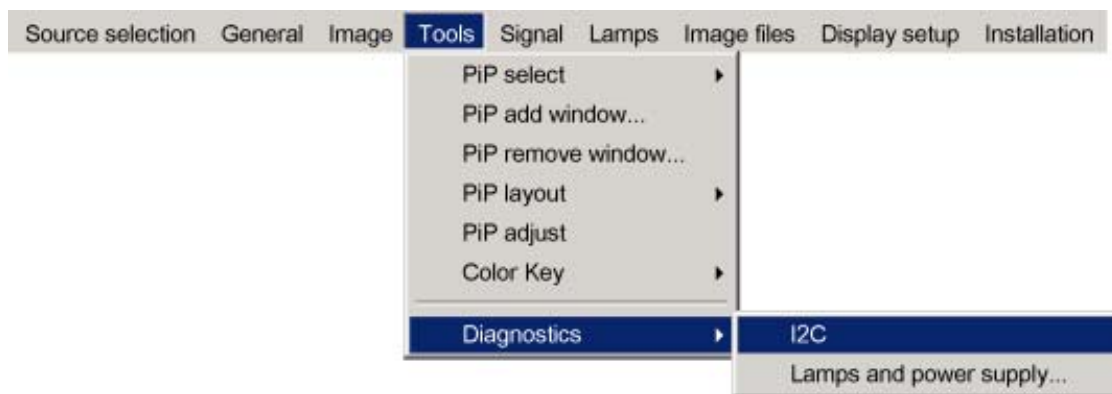

Image 12-1

How to display the Lamps and power supply diagnostic menu ?

1. Press **MENU** to activate the Tool bar
2. Press → to select the *Tools* item
3. Press ↓ to Pull down the *Tools* menu
4. Use ↑ or ↓ to select *Diagnostics*
5. Press → to pull down the menu
6. Press **ENTER** to select *Lamps and power supply* (image 12-2)

A text box is displayed (image 12-3)

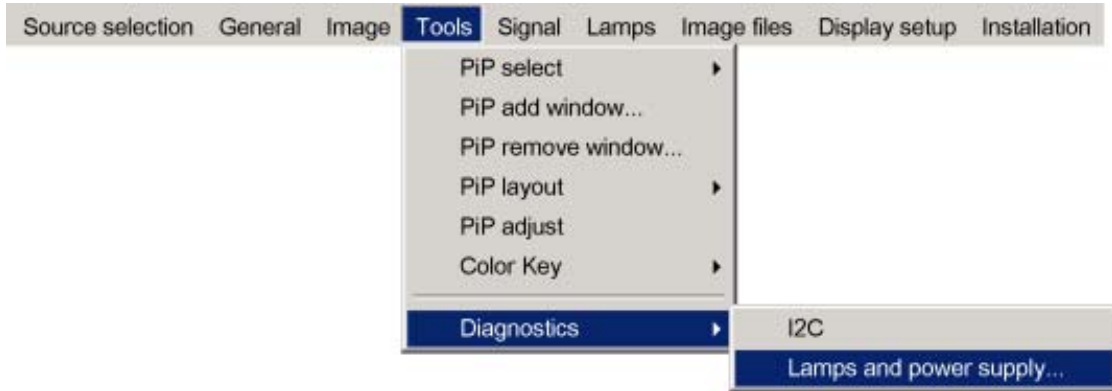

Image 12-2

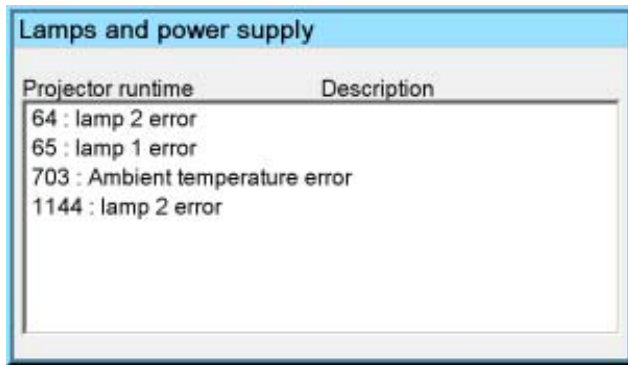

Image 12-3



For Barco certified service technicians only: For more information on possible hardware failures refer to the Service Manual.

12.2 FAQ table

What to do when... ?

Symptom	Possible cause	Check	References
The projector is working (operational mode) but Server is not running	<ul style="list-style-type: none"> The Projector ON state setting (in the "iQ Pro Server settings" menu) 	<ul style="list-style-type: none"> The setting should be "ON" 	
The projector is in standby mode and the Server is not running	<ul style="list-style-type: none"> The Projector Standby state setting (in the "iQ Pro Server settings" menu) 	<ul style="list-style-type: none"> The setting should be "ON" 	
No client/server communication in case of a point to point communication	<ul style="list-style-type: none"> IP address is not filled in correctly 	<ul style="list-style-type: none"> IP address 	
No client/server communication over the LAN	<ul style="list-style-type: none"> Client configuration 	<ul style="list-style-type: none"> Client configuration: projector name 	IT administrator
When using the DropZone, the iQ Pro server does not accept calls from client(s)	<ul style="list-style-type: none"> Netmeeting™ settings are incorrect 	<ul style="list-style-type: none"> Netmeeting™ settings 	IT administrator

Symptom	Possible cause	Check	References
When using the DropZone it is impossible to launch/store files	<ul style="list-style-type: none">No access the shared folder "Received"	<ul style="list-style-type: none">check guest account settings in Windows™	IT administrator
PC card is not working or influences the good working of the SBC	<ul style="list-style-type: none">incompatible PC card	<ul style="list-style-type: none">Check if the PC card driver is compatible with Windows™ XP	IT administrator

13. MAINTENANCE

Overview

- Cleaning the lens
- Cleaning the dustfilters

13.1 Cleaning the lens



To minimize the possibility of damage to optical coatings, or scratches to lens surfaces, we have developed recommendations for clean. **FIRST**, we recommend you try to remove any material from the lens by blowing it off with clean, dry deionized air. **DO NOT** use any liquid to clean the lenses.

Necessary tools

Toraysee™ cloth (delivered together with the lens kit). Order number : R379058.

How to clean the lens ?

Proceed as follow :

1. Always wipe lenses with a CLEAN Toraysee™ cloth.
2. Always wipe lenses in a single direction.
Warning: Do not wipe back and forwards across the lens surface as this tends to grind dirt into the coating.
3. Do not leave cleaning cloth in either an open room or lab coat pocket, as doing so can contaminate the cloth.
4. If smears occur when cleaning lenses, replace the cloth. Smears are the first indication of a dirty cloth.



CAUTION: Do not use fabric softener when washing the cleaning cloth or softener sheets when drying the cloth.

Do not use liquid cleaners on the cloth as doing so will contaminate the cloth.



Other lenses can also be cleaned safely with this Toraysee™ cloth.

13.2 Cleaning the dustfilters

Overview

- Dustfilters
- Cleaning

13.2.1 Dustfilters

Location of the filters

There are 4 filters located at different positions

1. Filter1: Lamp 1
2. Filter2 : Lamp 2
3. Filter 3 : X-Cube filter
4. Filter 4 : Input filter

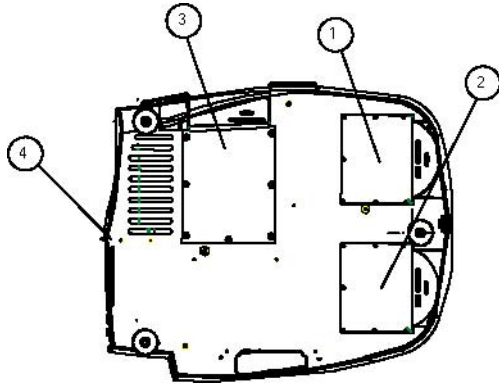

Image 13-1
location of the filters

- 1 lamp filter 1
- 2 lamp filter 2
- 3 x-cube filter
- 4 input filter

13.2.2 Cleaning

How to clean the dustfilters ?

1. Place the projector so as to access easily the filter to be cleaned
2. Push the handle downwards to unlock the filter. (image 13-2)
3. Slide out the filter (image 13-3, image 13-4, image 13-5)
See image 13-6.
4. Clean the dust filter with a dry cloth.
5. Re-insert the dust filter by sliding it back in the filter housing.

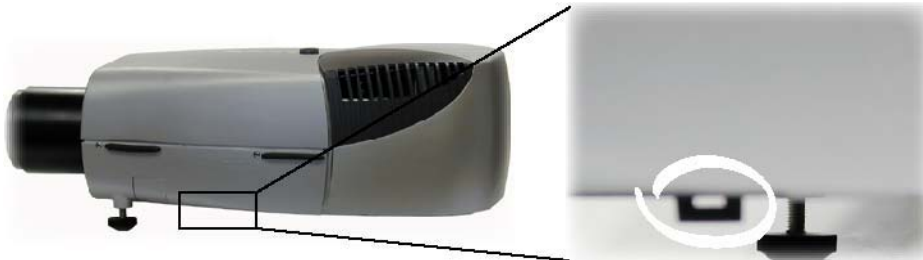

Image 13-2
Location of the x-cube filter and its handle



Image 13-3
Lamp filter removal



Image 13-4
lamp & X-Cube filters removed

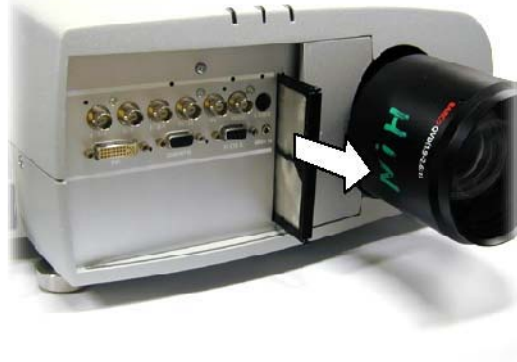

Image 13-5
Input filter removal



Image 13-6
Input filter removed



If the airflow is falling under a predetermined threshold value a warning will be displayed on the screen.

Message

An insufficient airflow is detected
Please check your dustfilter
at the airflow entrance

Image 13-7

At that time it is strongly recommended to replace or clean the dustfilter under the X-cube. Failing to do so, will strongly reduce the lifetime of the LCD's and the analyzers.

The manufacturer reserves itself the right to refuse warranty repair if the projector was working with dirty dustfilters.

INDEX

A

address 19
 RCU 19
 Address 20
 Projector address 20
 Adjustments 101
 lens 101
 advanced 32
 source selection 32
 Advanced 31
 AGC 65
 Auto Image 82
 AutoImage 93
 Setup 93
 automatic startup 24

B

Background 75
 blanking 61
 Blanking 94

C

Cleaning 167
 dustfilters 167
 Lens 167
 color keying 73
 configuration 116
 server 116
 connections 9
 input 9
 Connections 9, 14
 Communication 14
 Communications 14
 RS232 IN 14
 Input source connections 9
 facilities 9
 layers 9
 power connection 9
 Control 121
 description 121

D

diagnostics 131
 description 131
 Diagnostics 74
 Digital 13
 DVI 13
 Display Setup 90
 dropzone 135, 137
 dropping 137
 tools 135
 Dyancolor™ 56–57
 Interface 57
 L (Light Output) 56
 Dynacolor™ 52, 54, 57
 Basic 57
 Adjustment 57
 Start up 54

E

exchange 147–148, 151
 example 151
 installation 147
 troubleshooting 148
 Exchange 149
 exchange integration 153
 folder form 153

F

FAQ 164
 File 81, 84, 87–88
 copy 88
 delete 88
 edit 84
 load 81
 rename 87
 Filters 167–168
 cleaning 167–168
 location 167
 firmware 133
 upgrade 133
 Full screen representation 90

G

Gain 65–66
 automatic control 65
 manual control 66
 General 35–39
 audio 37
 Audio 37–38
 settings 38
 setup 37
 identification 39
 Standby Timer 36
 General menu 35–36
 freeze 36
 pause 35
 getting started 29
 adjust 29
 Getting started 27
 guidelines 145
 general network config 145
 Network 145

I

Identification screen 39
 Image 40, 46, 52
 Dynacolor™ 52
 resolution 46
 image files 89
 forced file load 89
 Image files 157
 standard 157
 Input 10–13
 Input source connection 10–13
 5-Cable input 10
 Composite Video input 11
 computer input 13
 DVI 13
 S-Video input 12
 input balance 61
 installation 7, 19, 21, 147
 address 19
 guidelines 7
 lens adjustments 21
 procedure 147
 Installation 9, 101
 Installation guidelines 7
 guidelines 7
 Safety 7
 safety warnings 7

L

lamp 76
 Lamp history 78
 Lamp mode 76

Language 23
 Layers 9
 input 9
 Lens 101, 167
 Cleaning 167
 lens adjustments 101
 Local keypad 15

M

Maintenance 167
 Menu 20–21, 23–24, 31, 40–44, 48–49, 65–67, 69–76, 78–81, 84, 87–88, 90–91, 93, 101, 104
 Image files menu 81, 84, 87–88
 copy file 88
 delete file 88
 edit file 84
 load file 81
 rename file 87
 Image menu 40–44, 48–49, 65–66
 AGC on video 65
 aspect ratio 44
 Brightness 41
 color 42
 color temperature 49
 contrast 41
 filmmode detection 49
 Gamma 43
 Keystone 48
 manual gain control 66
 noise reduction 43
 phase 43
 settings 40
 sharpness 42
 Tint 42
 Installation menu 20–21, 23–24, 90–91, 93, 101, 104
 AutoImage Setup 93
 change password 104
 Full screen representation 90
 language 23
 lens adjustments 101
 projector address 20
 projector orientation 21
 Quick access keys 24
 Sliderbox position 93
 Startup screen 91
 Take screenshot 91
 textbox 91
 Lamp menu 76, 78–80
 history 78
 Mode 76
 reset runtime 79
 Runtime warning 80
 runtimes 76
 Signal menu 74–75
 background 75
 switching mode 74
 Tools 67
 PiP 67
 Tools menu 69–73
 PiP add window 69
 PiP Adjust 73
 PiP delete layout 72
 PiP layout 70
 PiP remove window 70
 PiP rename layout 71
 PiP Save 70
 PiP select 69
 Using the dialog boxes 31
 menu bar 92
 Menu structure 31
 Using the dialog boxes 31

N

Native resolution 46
 network 111, 113, 122–123, 128, 135, 139, 142–143, 145
 additional config info 145
 configuration 113
 control 122–123, 128
 advanced 128
 general 122
 interface 122
 source selection 123
 dropzone 135, 139
 remote desktop sharing 139
 Dropzone 139
 file manager 139
 DropZone 135, 142
 settings 142
 start up 135
 Server 111
 start up 111
 web 143
 Network 107–111, 121, 123, 126, 129, 131–132
 architecture 107
 configuration 132
 E-mail 132
 Connections 110
 control 129
 advanced lens adjustments 129
 advanced options 129
 Control manager 123, 126
 image settings 126
 PiP 123
 diagnostics manager 131
 functionality 108
 Getting started 109
 installing 111
 software 111
 Projector 121
 control 121
 No signal 75
 background 75

O

Orientation 21
 projector orientation 21
 outlook integration 154
 limitations 154
 outlook intagratin 151

P

Packaging 5
 parameter 149
 list 149
 Password 104
 change password 104
 PiP 69–73
 add window 69
 adjust 73
 layout 70
 Layout 70–72
 delete 72
 rename 71
 save 70
 remove window 70
 select 69
 PiP layout 27
 Preferences 23
 Projector 18
 Switch on 18

Q

Quick access keys 24

R

- RCU 15–16
 - Terminology 16
 - Overview 16
- Runtime 79–80
 - reset 79
 - warning 80

S

- Scenergix 100
 - Black level 100
- Screenshot 91
- security 102
- setup 24
 - automatic startup 24
- Setup 15
- Sliderbox position 93
- SNMP 155
 - installation 155
 - integration 155
- Soft Edge 95, 97
 - Border adjustment 97
 - Horz. overlap zone 97
 - Introduction 95
- Softedge 97
 - horizontal 97
 - overlap zone 97
- Source 32, 74
 - Source selection 32
 - switching mode 74
- source files 157
 - standard 157
- Source selection 33–34
 - composite video 33

- S-Video 34
- specifications 109
- Start up 27
- Startup screen 91
- status bar 92
- Switching 74
 - switching mode 74

T

- Textbox 91
- Timer 36
- Tools 67
 - advanced 67
 - tools 67
- troubleshoot 163
 - OSD 163

U

- Unpacking 5

V

- Video 11–12, 65–66
 - AGC 65
 - Composite Video 11
 - manual gain control 66
 - S-Video 12

W

- White peaking 51